



City of Flint, Michigan

Third Floor, City Hall
1101 S. Saginaw Street
Flint, Michigan 48502
www.cityofflint.com

Meeting Agenda – FINAL Wednesday, June 17, 2026 5:00 PM

City Council Chambers

FINANCE COMMITTEE

Judy Priestley, Chairperson, Ward 4

Leon El-Alamin, Ward 1
LaShawn Johnson, Ward 3
Tonya Burns, Ward 6
Dennis Pfeiffer, Ward 8

Ladel Lewis, Ward 2
Jerri Winfrey-Carter, Ward 5
Candice Mushatt, Ward 7
Jonathan Jarrett, Ward 9

Davina Donahue, City Clerk

ROLL CALL

READING OF DISORDERLY PERSONS CITY CODE SUBSECTION

Any person that persists in disrupting this meeting will be in violation of Flint City Code Section 31-10, Disorderly Conduct, Assault and Battery, and Disorderly Persons, and will be subject to arrest for a misdemeanor. Any person who prevents the peaceful and orderly conduct of any meeting will be given one warning. If they persist in disrupting the meeting, that individual will be subject to arrest. Violators will be removed from the meetings.

REQUEST FOR AGENDA CHANGES/ADDITIONS

PUBLIC COMMENT

Members of the public who wish to address the City Council or its committees must register before the meeting begins. A box will be placed at the entrance to the Council Chambers for collection of registrations. No additional speakers or slips will be accepted after the meeting begins.

Members of the public shall have no more than three (3) minutes per speaker during public comment, with only one speaking opportunity per speaker.

COUNCIL RESPONSE

Councilmembers may respond once to all public speakers only after all public speakers have spoken. An individual Councilmember's response shall be limited to two (2) minutes.

CONSENT AGENDA

Per the amended Rules Governing Meetings of the Flint City Council (as adopted by the City Council on Monday, April 22, 2024), the Chair may request the adoption of a "Consent Agenda". After a motion to adopt a Consent Agenda is made and seconded, the Chair shall ask for separations. Any agenda item on a Consent Agenda shall be separated at the request of any Councilmember. After any separations, there is no debate on approving the Consent Agenda – it shall be voted on or adopted without objection.

RESOLUTIONS

260211 2026 Operating Millage/City of Flint Downtown Development Authority District

Resolution resolving that the City Council of the City of Flint adopts the levy of 1.8806 mills for the ensuing (FY2026-2027) Downtown Development Authority operating budget.

260212 Pomp's Tire Service/Purchase of Tires/FY26

Resolution resolving that the City Officials are authorized to do all the necessary things to purchase new tires need for all City vehicles with Pomp's Tire Service for the FY26 (07/01/25-06/30/26) additional funding of \$12,500, for a total amount NOT-TO-EXCEED \$87,500.00. [NOTE: The

purchase includes change order of additional \$12,500.00 for Tires for Fleet vehicles, making a total of \$87,500.00 for FY26. Pomp's Tire Service's provides repairs and maintenance on all tires for all vehicles owned or leased by the City of Flint.]

260213 Contract/PrintComm/Printing and Mailing/Consumer Confidence Reports

Resolution resolving that the City Officials are to do all things necessary to enter into a contract with Print Comm for the five (5) year printing/mailing of consumer confidence reports for a total contract amount NOT-TO-EXCEED \$108,806.00 plus any adjustments for postal costs to mail said report. (Water Fund) \$13,549.00 from the FY26 adopted budget, \$22,039.00 pending adoption of the FY27 budget, \$23,141.00 pending adoption of the FY28 budget, \$24,428.00 pending adoption of the FY29 budget, and \$25,649.00 pending adoption of the FY30.

260214 Change Order/Lake Star Construction Services, Inc./Lead-Based Paint Abatement

Resolution resolving that the City Officials are authorized to amend its contract with Lake Star Construction Services, Inc. for Lead Remediation Services and increase the contracted price for services in an amount NOT-TO-EXCEED \$21,000.00. [NOTE: The Division of Lead-Based Paint Hazard Control awarded a qualified vendor, Lake Star Construction Services, Inc., Detroit, MI, the proposal at a requested FY23 cost of \$197,480.00 for Lake Star to conduct lead abatement services and Healthy Homes repairs of all hazards on (11) units within the city. Additional funding of \$21,000 is required to complete the final two units under the original scope of work.]

260215 Contract/Beatrice Construction LLC/Accessibility Modifications/Three Single Family Homes

Resolution resolving that the City Officials are authorized to award MI Neighborhood 1.0 funding and to enter into a contract with Beatrice Construction, LLC for the remainder of the grant period, up to August 31, 2026 in a total amount NOT-TO-EXCEED \$84,597.50 for services relating to their performing accessibility modifications to three single family homes

within the City of Flint as part of the Occupied Housing Accessibility Rehab Program. [NOTE: In December of 2024, The City Council accepted the award of \$472,000.00 from the Michigan State House Development Authority (MSHDA) for the City's Occupied Housing Accessibility Rehab Program through MI Neighborhood 1.0 Grant NDD-2023-49-MIN. (Performance Period October 2024-August 31, 2026). Which was received and approved through resolution 240484-T adopted December 16, 2024. Beatrice Construction LLC will enter a performance-based contract over the duration of the grant program, providing accessibility rehabs for three of the 19 properties, and will ensure compliance with both City of Flint requirements and MSHDA MI Neighborhood 1.0 compliance.]

260216 Samsara Inc./Annual 36-Month/Renewal Subscription Service/FY27

Resolution resolving that the Flint City Council authorizes the proper city officials to purchase the annual subscription for Samsara Inc, GPS tracking system used for the management of the city's fleet vehicles in an amount NOT-TO-EXCEED \$92,754.00 for FY27 (07/01/26 to 06/30/27). [NOTE: The Fleet Division is requesting approval to renew the Samsara, Inc. subscription GPS service to support tracking of city-owned vehicles.]

260217 Motorola Solutions, Inc./Purchase Portable Radios, Batteries and Chargers/Flint Fire Department

Resolution resolving that the appropriate City Officials are authorized to do all things necessary, to approve spending from funding source account 101-336.000-977.000 in the amount of \$108,815.25, AND, further resolving that the Division of Purchases and Supplies is authorized to issue a Purchase Order to Motorola Solutions, Inc. in an amount NOT-TO-EXCEED \$108,815.25 for the purchase of 15 portable radios, batteries and 10 desktop chargers. [NOTE: Portable radios are an emergent need for Flint Firefighters to effectively communicate while on emergency scenes, enhancing safety while searching and performing various fireground operations.]

260218 LaFontaine Chevrolet Plymouth/Purchase Two (2) Chevrolet Cargo Vans

Resolution resolving that the Division of Purchases and Supplies, upon City Council's approval, is authorized to issue a Purchase Order to LaFontaine Chevrolet Plymouth of Plymouth, MI for the purchase of two (2) Chevrolet cargo vans in an amount NOT-TO-EXCEED \$124,566.50 for FY26 (07/01/25-06/30/26). [NOTE: These vans will replace (2) 2008 step vans which have already been turned in for auction. These vans will be utilized by the service section of the water department for the completion of their daily work orders.]

260219 Support/FY2026 (3X) Bridge Applications/Hamilton Avenue Over Flint River/Stewart Avenue Over C&O RR/Beach Street Over Thread Creek

Resolution resolving that the appropriate City Officials are authorized to execute and submit all documents necessary for the Local Bridge Program applications and to identify the required local match, subject to final award, approval, and budget availability. [NOTE: The department of Public Works, Transportation Division, is seeking funding through the State of Michigan Local Bridge Program Call for Applications for Funding Year 2029, and the City of Flint Transportation Division has prepared applications for the Hamilton Avenue over Flint River Bridge (2835), Stewart Avenue over C&O RR Bridge (2837), and Beach Street over Thread Creek (2857) Bridge Projects.]

260220 Power Initiative/Flint Recast Program/Implementation Using Carry-Over Funds

Resolution resolving that the appropriate City Officials, upon the City Council approval, are authorized to do all things necessary, including executing any necessary agreements, to appropriate funding from the funding account 296-649.700-801.000 to Power Initiative in the amount of \$140,000.00. [NOTE: Recast is seeking to spend its carried over funds with an organization that can help reach the final goals of Recast which include funding for the smaller applicant organizations, youth event coordination, and job training and orientation. Power Initiative was chosen because of their past performance and their connection to the Recast processes. Their work is grounded in trust, collaboration, and respect and values that allow

them to deliver customized, innovative solutions that truly reflect the unique goals of each organization.]

260221 Contract/Blackout Construction LLC/Accessibility Modifications/16 Single Family Homes

Resolution resolving that the City Officials are authorized to award MI Neighborhood 1.0 funding and to enter into a contract with Blackout Construction, LLC for the remainder of the grant period, up to August 31, 2026 in a total amount NOT-TO-EXCEED \$228,088.90 for services relating to their performing accessibility modifications to 16 single family homes within the City of Flint as part of the Occupied Housing Accessibility Rehab Program. [NOTE: In December of 2024, The City Council accepted the award of \$472,000.00 from the Michigan State House Development Authority (MSHDA) for the City's Occupied Housing Accessibility Rehab Program through MI Neighborhood 1.0 Grant NDD-2023-49-MIN. (Performance Period October 2024-August 31, 2026). Which was received and approved through resolution 240484-T adopted December 16, 2024. Blackout Construction LLC will enter a performance-based contract over the duration of the grant program, providing accessibility rehabs for 16 of the 19 properties, and will ensure compliance with both City of Flint requirements and MSHDA MI Neighborhood 1.0 compliance.]

260222 Accept/FY26 One-Time Enhancement Grant/Michigan Department of Labor and Economic Opportunity (LEO)/Improvements to Haskell Community Center

Resolution resolving that the appropriate City Officials are authorized to do all things necessary including executing any necessary agreements, to accept the Michigan Department of Labor and Economic Opportunity FY26 One-Time Enhancement Grant Program award, Grant No. E20260096, in the amount of \$500,000, for capital improvements at Haskell Community Center, AND, further resolving that the FY26 budget shall, upon adoption of this resolution, be amended to appropriate grant revenues and expenditures, AND, further resolving that the FY27 and all subsequent fiscal years for as long as grant funds remain shall be amended as necessary to appropriate remaining grant expenditures and revenues.

260223 Truck & Trailer Specialties Business/Purchase 2 New Salting and Plowing Vehicles

Resolution resolving that the Proper City Officials are authorized to do all the necessary things to purchase 2 new salting and plowing vehicles with Truck & Trailer Specialties for the FY27 (07/01/26-06/30/27) in total amount NOT-TO-EXCEED \$654,226.00. [NOTE: The Fleet Division is requesting approval to purchase new vehicles from Truck & Trailer Specialties, to support plowing and salting city streets for departmental operational needs.]

260224 Ace Saginaw Paving Company/Asphalt Paving Materials

Resolution resolving that the Division of Purchases & Supplies is authorized to issue purchase orders to Ace Saginaw Paving Company for asphalt paving materials for FY27, in the amount NOT-TO-EXCEED \$2,497,150.00.

260225 Contract/Lighthouse Insurance Group/City of Flint/Property and Liability Coverage

Resolution resolving that the appropriate City officials are authorized to enter into a contract with Lighthouse Insurance Group to provide the City with property and liability coverage for the period 7/1/26 through 7/1/27 at a combined premium cost amount NOT-TO-EXCEED \$2,669,189.93 Funding for these services will come from Insurance Fund.

260226 Approve/Sale of City Owned Property/Michigan Department of Transportation/Road Reconstruction and Bridge Replacement Project

Resolution resolving that the Flint City Council authorizes the sale of part of Parcel No. 41-19-131-021 as identified in the Legal Description-Attachment A, to the Michigan Department of Transportation for the good faith offer of \$11,200 subject to the City's retainage of all easements.

SPECIAL ORDERS/DISCUSSION ITEMS

260229 Special Order/Greater Flint Health Coalition/Grants Management

A Special Order as requested by Council President Mushatt in order to allow for a 15-minute presentation from the Greater Flint Health Coalition to discuss managing dollars on behalf of the City to give grants to organizations that serve the homeless population in our community.

ADJOURNMENT

260211



RESOLUTION NO.: _____
PRESENTED: 6-17-2026
ADOPTED: _____

RESOLUTION TO ADOPT THE 2026 OPERATING MILLAGE RATE OF 1.8806 MILLS FOR THE CITY OF FLINT'S DOWNTOWN DEVELOPMENT AUTHORITY DISTRICT TO BE LEVIED ON THE TAXABLE VALUATION FOR ALL REAL AND PERSONAL PROPERTY LOCATED IN THE CITY OF FLINT'S DOWNTOWN DEVELOPMENT AUTHORITY DISTRICT

BY THE MAYOR AND CITY COUNCIL:

The City of Flint under P.A. 206 of 1893, as amended (MCL 211.24e), provides that a public hearing be held by a local taxing unit that proposes to increase operating revenues over the maximum amount allowed to be levied without a hearing; and

The proposed millage rate must be established by a resolution adopted by the governing body of the taxing unit before it conducts the hearing; and

Based upon the decrease in the Taxable Valuation of all taxable real and personal property located in the Downtown Development Authority in the City of Flint, the levy of ad valorem taxes will not generate any increase in revenues which would exceed the maximum level allowed by MCL 211.24e(2), as amended.

BE IT RESOLVED, that the City Council of the City of Flint adopts the levy of 1.8806 mills for the ensuing (FY2026-2027) Downtown Development Authority operating budget.

APPROVED AS TO FORM:

APPROVED AS TO FINANCE:

JoAnne Gurley (May 16, 2026 14:02:28 EDT)
Joanne Gurley, City Attorney

Phillip Moore (May 15, 2026 11:51:14 EDT)
Phillip Moore, Chief Financial Officer

Sheldon A. Neeley, Mayor

CITY COUNCIL:



RESOLUTION NO.: 260212

PRESENTED: 6-17-2026

ADOPTED: _____

**BY THE CITY
ADMINISTRATOR:**

RESOLUTION AUTHORIZING THE PURCHASE OF TIRES FROM POMP'S TIRE SERVICE FOR FY26

WHEREAS, The City of Flint Finance Department, Fleet Division, is requesting approval to purchase new tires from Pomp's Tire Service, to support tire services for all city vehicles for departmental operational needs.

WHEREAS The purchase includes change order of additional \$12,500.00 for Tires for Fleet vehicles, making a total of \$87,500.00 for FY26. Pomp's Tire Service's provides repairs and maintenance on all tires for all vehicles owned or leased by the City of Flint.

Funding is to come from the following account(s):

Account Number	Account Name/ Grant Code	Amount
661-229.000-752.000	Supplies	\$12,500.00
	FY27 TOTAL	\$12,500.00

IT IS RESOLVED that the Proper City Officials are hereby authorized to do all the necessary things to purchase new tires need for all City vehicles with Pomp's Tire Service for the for FY26 (07/01/25-06/30/26) additional funding of \$12,500, for a total amount not-to-exceed \$87,500.00.

APPROVED AS TO FORM:

JoAnne Gurley
JoAnne Gurley (Jun 5, 2026 15:42:48 EDT)
Joanne Gurley, City Attorney

APPROVED AS TO FINANCE:

Paul Borte
Paul Borte (Jun 5, 2026 11:50:33 EDT)
For Phillip Moore, Chief Financial Officer

FOR THE CITY OF FLINT:

CDE
Clyde Edwards/ A0672 (Jun 5, 2026 16:44:10 EDT)
Clyde Edwards, City Administrator

APPROVED BY CITY COUNCIL:

APPROVED AS TO PURCHASING:

Lauren Rowley
Lauren Rowley, Purchasing Manager



STAFF REVIEW FORM

Effective: April 1, 2026

(Do not alter or modify this form without written permission from the City Administrator)

TODAY'S DATE: 5-26-26

BID PROPOSAL #:

AGENDA ITEM TITLE: Tires, Tire Repair & Miscellaneous Tire Services

PREPARED BY: Adelaide Schiller, Fleet Coordinator

VENDOR NAME: Pomp's Tire Services

Section 1. BACKGROUND/SUMMARY OF PROPOSED ACTION..

Vendor Compliance (This vendor has been properly vetted and the responses are below) :

Federal gov't	(All documentation current, no violations)	<input checked="" type="checkbox"/> YES	<input type="checkbox"/> NO
State gov't	(All documentation current, no violations)	<input checked="" type="checkbox"/> YES	<input type="checkbox"/> NO
City of Flint	(All documentation current, no violations)	<input checked="" type="checkbox"/> YES	<input type="checkbox"/> NO

The requesting authority is validating that this vendor has been in full compliance with all past contract provisions and has not violated the terms of any contract with the City of Flint.

NOTE: Preparer **MUST** include a response to the conditions below:

- Did we do an assessment of first consideration to internal City of Flint staff and resources (explain)?
- Why was this vendor chosen?
- What history does this vendor have with the City of Flint?
- What steps will be taken to do a post-performance of the vendor?

Fleet Services is requesting added money to purchase order # 26-008682 in the amount of \$12,500.00. Pomp's Tire Service's provides repairs and maintenance on all tires for all vehicles owned or leased by the City of Flint. This added money is for Tire repairs and Tires needed.

PROCUREMENT (MUST BE SPECIFIED)

Please specify how this vendor was identified: (Check one)

- Sole Source (Please attach sole source statement to requisition)
- Competitive Bid Process (Please attach bid tabulation/documents to requisition)
- Cooperative Contract (MIDeal, Sourcewell, GSA, or other municipality)

*Contract must be attached to your requisition and contract must appear on the vendor's quote for goods/services

- (3) Quotes (please attach all quotes to your requisition)



STAFF REVIEW FORM

Effective: April 1, 2026

(Do not alter or modify this form without written permission from the City Administrator)

Section 2. PREVIOUS ALLOCATIONS (INCLUDE ALL ACCOUNTS USED FOR THIS PURPOSE)/ PROVIDE RESOLUTION OR CONTRACT INFORMATION THAT APPLIES..

Fiscal Year	Account	PO Number	FY PO Amount	FY Expensed	Resolution
FY25	661-000.000-101.114	25-007260	\$100,000	\$83,773.77	
FY24	661-000.000-101.114	24-006313	\$100,000	\$64,483.62	
FY23	661-000.000-101.114	23-003793	\$100,000	\$92,244.25	
FY22	661-000.000-101.114	22-003793	\$100,000	\$79,936.19	

Section 3. POSSIBLE BENEFIT TO THE CITY OF FLINT (RESIDENTS AND/OR CITY OPERATIONS) INCLUDE PARTNERSHIPS AND COLLABORATIONS..

Partnering with Pomp's Tire Service offers the City of Flint a reliable and cost-effective solution for managing its fleet's tire needs. With a strong regional presence and a reputation for timely, professional service, Pomp's can help ensure city vehicles remain operational and safe, minimizing downtime due to tire-related issues. Their comprehensive offerings include new tires, tire repairs, routine maintenance streamline procurement and reduce administrative burden by consolidating services under one trusted provider.

Section 4. FINANCIAL IMPLICATIONS..

IF ARPA related Expenditure:

Has this request been reviewed by E&Y Firm: YES NO IF NO, PLEASE EXPLAIN:

NOTE: Accountant MUST include the following information:

- What is the total amount budgeted for this purpose?
- What percentage is being spent with this vendor?
- What is the justification for spending this amount of money with this vendor?
- What percentage is being spent out of each line item used in this request?
- List all the known budgeted funds from that line item.

Total Budget is \$226,000.00
 Full amount of this is \$87,500.00
 39% of total line budget.

BUDGETED EXPENDITURE? YES NO IF NO, PLEASE EXPLAIN:



STAFF REVIEW FORM

Effective: April 1, 2026

(Do not alter or modify this form without written permission from the City Administrator)

Dept.	Name of Account	Account Number	Grant CODE	Amount
3331	Supplies	661-229.000-752.000	N/A	\$12,500.00
FY26 GRAND TOTAL				\$12,500.00

WHEN APPLICABLE, IF MORE THAN ONE (1) YEAR, PLEASE ESTIMATE TOTAL AMOUNT FOR EACH BUDGET YEAR: (This will depend on the term of the bid proposal)

BUDGET YEAR 1: _____
 BUDGET YEAR 2: _____
 BUDGET YEAR 3: _____

OTHER IMPLICATIONS (i.e., collective bargaining).. _____

PRE-ENCUMBERED? YES NO REQUISITION NO: 26-0011529

ACCOUNTING APPROVAL: *Agie* Jun 5, 2026 11:01:26 EDT Date: _____

WILL YOUR DEPARTMENT NEED A CONTRACT? YES NO

Section 5. RESOLUTION DEFENSE TEAM..

(Place the names of those who can defend this resolution at City Council)

	NAME	PHONE NUMBER
1	Marquita Blair	810.423.5650
2		
3		
4		

STAFF RECOMMENDATION: (PLEASE SELECT): APPROVED NOT APPROVED



STAFF REVIEW FORM

Effective: April 1, 2026

(Do not alter or modify this form without written permission from the City Administrator)

DEPARTMENT HEAD SIGNATURE: Marquita Blair, Fleet Administrator
(Name, Title)

ADMINISTRATION APPROVAL:

(\$20,000 or above spending authorizations)

Section 6. VENDOR EVALUATION..

Business Title:	Pomp's Tire Service	Vendor ID:	
Review Period:		Department:	Fleet
Project Name:	Tire Service	Project Type:	

Vendor Goals:

This Vendor is expected to get our parts and supplies needed as soon as possible and in a timely manner.

	1 = Poor	2 = Fair	3 = Sufficient	4 = Good	5 = Excellent
Job Knowledge:	<input type="checkbox"/>	<input type="checkbox"/>	<input type="checkbox"/>	<input type="checkbox"/>	<input checked="" type="checkbox"/>
Work Quality:	<input type="checkbox"/>	<input type="checkbox"/>	<input type="checkbox"/>	<input type="checkbox"/>	<input checked="" type="checkbox"/>
Timeliness:	<input type="checkbox"/>	<input type="checkbox"/>	<input type="checkbox"/>	<input type="checkbox"/>	<input checked="" type="checkbox"/>
Compliance with Contract:	<input type="checkbox"/>	<input type="checkbox"/>	<input type="checkbox"/>	<input type="checkbox"/>	<input checked="" type="checkbox"/>
Warranty (If Product):	<input type="checkbox"/>	<input type="checkbox"/>	<input type="checkbox"/>	<input type="checkbox"/>	<input type="checkbox"/>
Responsiveness:	<input type="checkbox"/>	<input type="checkbox"/>	<input type="checkbox"/>	<input type="checkbox"/>	<input checked="" type="checkbox"/>
Cost Effectiveness:	<input type="checkbox"/>	<input type="checkbox"/>	<input type="checkbox"/>	<input type="checkbox"/>	<input checked="" type="checkbox"/>
Dependability:	<input type="checkbox"/>	<input type="checkbox"/>	<input type="checkbox"/>	<input type="checkbox"/>	<input checked="" type="checkbox"/>
Total Performance:	<input type="checkbox"/>	<input type="checkbox"/>	<input type="checkbox"/>	<input type="checkbox"/>	<input checked="" type="checkbox"/>
Overall Rating:	<input type="checkbox"/>	<input type="checkbox"/>	<input type="checkbox"/>	<input type="checkbox"/>	<input checked="" type="checkbox"/>



STAFF REVIEW FORM

Effective: April 1, 2026

(Do not alter or modify this form without written permission from the City Administrator)

DEFECTS (IF ANY): IF CHECKED, PLEASE EXPLAIN:

N/A

Performance / Other Comments:

Pomp's Tire Service has consistently provided reliable and responsive tire maintenance and repair services. Their team demonstrates professionalism, quality workmanship, and a commitment to minimizing equipment downtime through timely service and support. They have been a dependable vendor, helping maintain safe and efficient fleet operations while delivering excellent customer service.

REVIEWER'S SIGNATURE:

Marquita Blair (Jun 5, 2026 11:08:21 EDT)

Date:



SEALED PROPOSALS RECEIVED IN THE DIVISION OF PURCHASES & SUPPLIES
TIRES

One Year Extension of Bid# 24000016
Approximate Annual Quantities – Not Guaranteed
Furnish as requested for the period 7/1/25 – 6/30/26

Bidder# 1: Jerry's Tire
Flint, MI
Incomplete bid. Required information was not provided.

Bidder# 2: Pomp's Tire
Flint, MI

PRICING	YEAR 1
Section #1 Total:	\$6,578.82
Fire Tire Total:	\$3,311.10
Police Tire Total:	\$1,067.25
Service/Repairs Total:	\$134.00

Margrita Bial (Jul 17, 2025 13:28 EDT)

City of Flint; Fleet Administrator

Cindy Hawley (Jul 17, 2025 13:33 EDT)

A SPECIAL NOTE FROM THE PURCHASING DIVISION
Bid results posted are before evaluation team review and award recommendation.

Business Search

As of 6/3/2026:

- * Business Filings are processed through 05/29/2026.
- * Renewals and Restorations (for entities returning to good standing) are processed through 06/01/2026.

To file a document or annual report/statement for an existing entity, search for the entity, select Request Access from the slide-out drawer, complete the questions, refresh the webpage, and select File Subsequent Document or File Annual Report/Statement.

The same process applies to order certificates and copies.

You must be logged in to file documents or order certificates and copies. Click on the Login button in the top right. If you do not have an account, create one. The credentials from the previous system did not transfer to this system.

Business Search Info: v

Pomps Tire Service

Q *

Advanced v

Results: 1

Name	Filing Date	Status	AR Standing	Entity Type	Entity ID#	Agent	AR Due Date
POMPS TIRE SERVICE, INC. >	10/10/2002	Active	Good	Foreign Profit Corporation	801043461	CSC-LAWYERS INCORPORATING SERVICE (COMPANY)	05/15/2027

Entity Information

POMP'S TIRE SERVICE, INC. • Active Registration

Expiration Date
Jan 3, 2027

Unique Entity ID CAGE/NCAGE

L581EX8Y41M3 1T1Z4

Mailing Address
2315 S Calhoun RD
New Berlin, Wisconsin
53151-2707, United States

Physical Address
2315 S Calhoun RD
New Berlin, Wisconsin
53151-2707, United States

Purpose of Registration
All Awards

Version
Current Record ▼

BUSINESS INFORMATION

Doing Business As

URL

Domestication Data

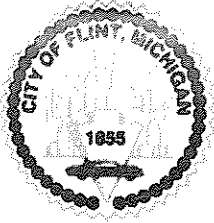

RESOLUTION NO.: 260213

PRESENTED: 6-17-2026

ADOPTED: _____

BY THE CITY ADMINISTRATOR:

RESOLUTION TO PRINTCOMM FOR THE PRINTING/MAILING OF CONSUMER CONFIDENCE REPORTS

WHEREAS, The Department of Finance - Purchasing solicited proposals (#26000541) for the five (5) year printing/ mailing of consumer confidence reports as requested by the DPW/Water Plant; and

WHEREAS, Print Comm was the lowest responsive bidder. Funding for said services will come from the following account: 591-545.200-900.000.

Account Number	Account Name/ Grant Code	Amount
591-545.200-900.000	Printing & Publishing	\$13,549.00
	FY2026 GRAND TOTAL	\$13,549.00

BE IT RESOLVED, That the Appropriate City Officials, are to do all things necessary to enter into a contract with Print Comm for the five (5) year printing//mailing of consumer confidence reports for a total contract amount not to exceed \$108,806.00 plus any adjustments for postal costs to mail said report. (Water Fund) \$13,549.00 from the FY26 adopted budget, \$22,039.00 pending adoption of the FY27 budget, \$23,141.00 pending adoption of the FY28 budget, \$24,428.00 pending adoption of the FY29 budget, and \$25,649.00 pending adoption of the FY30 budget.

APPROVED AS TO FORM:

JoAnne Gurley (Jun 9, 2026 15:24:38 EDT)
JoAnne Gurley, Chief Legal Officer

APPROVED AS TO FINANCE:

Phillip Moore (Jun 2, 2026 21:39:19 EDT)
Phillip Moore, Chief Financial Officer

FOR THE CITY OF FLINT:

Clyde Edwards / A0671 (Jun 4, 2026 15:42:32 EDT)
Clyde Edwards, City Administrator

APPROVED BY CITY COUNCIL:



STAFF REVIEW FORM

Effective: April 1, 2026

(Do not alter or modify this form without written permission from the City Administrator)

TODAY'S DATE: May 12, 2026
 BID PROPOSAL #: 26000541
 AGENDA ITEM TITLE: Printing and Mailing of Consumer Confidence Report (CCR)
 PREPARED BY: Yolanda Gray – Department of Public Works & Utilities
 VENDOR NAME: Print Comm

Section 1. BACKGROUND/SUMMARY OF PROPOSED ACTION..

Vendor Compliance (This vendor has been properly vetted and the responses are below) :

Federal gov't	(All documentation current, no violations)	<input checked="" type="checkbox"/> YES	<input type="checkbox"/> NO
State gov't	(All documentation current, no violations)	<input checked="" type="checkbox"/> YES	<input type="checkbox"/> NO
City of Flint	(All documentation current, no violations)	<input checked="" type="checkbox"/> YES	<input type="checkbox"/> NO

The requesting authority is validating that this vendor has been in full compliance with all past contract provisions and has not violated the terms of any contract with the City of Flint.

NOTE: Preparer MUST include a response to the conditions below:

- Did we do an assessment of first consideration to internal City of Flint staff and resources (explain)?
- Why was this vendor chosen?
- What history does this vendor have with the City of Flint?
- What steps will be taken to do a post-performance of the vendor?

The City of Flint Purchasing department solicited bids for a vendor to print and mail water quality consumer confidence reports (CCR) as mandated by the Department of Environmental, Great Lakes, and Energy (EGLE) for a five (5) year agreement during the time period of June 2026 through June 2031. The lowest responsive bidder was Print Comm. There were two (2) options requested due to printing being required every six (6) months and not once a year, after year 2026. Print Comm was selected as the lowest qualified vendor. Print Comm has rendered printing and mailing services for over 10 years to the City of Flint. Proofs/drafts of products are provided to ensure all requirements are met for printing and mailing. Post performance measures for Print Comm are measured in the quality of final product and timeliness of mailing.

PROCUREMENT (MUST BE SPECIFIED)

Please specify how this vendor was identified: (Check one)

- Sole Source (Please attach sole source statement to requisition)
- Competitive Bid Process (Please attach bid tabulation/documents to requisition)
- Cooperative Contract (MIDeal, Sourcewell, GSA, or other municipality)

*Contract must be attached to your requisition and contract must appear on the vendor's quote for goods/services

- (3) Quotes (please attach all quotes to your requisition)



STAFF REVIEW FORM

Effective: April 1, 2026

(Do not alter or modify this form without written permission from the City Administrator)

Section 2. PREVIOUS ALLOCATIONS (INCLUDE ALL ACCOUNTS USED FOR THIS PURPOSE)// PROVIDE RESOLUTION OR CONTRACT INFORMATION THAT APPLIES..

Fiscal Year	Account	PO Number	FY PO Amount	FY Expensed	Resolution
2022	591-545.200-900.000		11,282.88	11,282.88	
2023	591-545.200-900.000		12,128.72	12,128.72	
2024	591-545.200-900.000		18,905.50	15,905.50	
2025	591-545.200-900.000		13,806.06	13,806.06	

Section 3. POSSIBLE BENEFIT TO THE CITY OF FLINT (RESIDENTS AND/OR CITY OPERATIONS) INCLUDE PARTNERSHIPS AND COLLABORATIONS..

The Consumer Confidence Report (CCR) benefits the City of Flint as an important tool to inform residents about water quality and any contaminants that have been found in the water.

Section 4. FINANCIAL IMPLICATIONS..

IF ARPA related Expenditure:

Has this request been reviewed by E&Y Firm: YES NO IF NO, PLEASE EXPLAIN:

NOTE: Accountant MUST include the following information:

- What is the total amount budgeted for this purpose?
- What percentage is being spent with this vendor?
- What is the justification for spending this amount of money with this vendor?
- What percentage is being spent out of each line item used in this request?
- List all the known budgeted funds from that line item.



STAFF REVIEW FORM

Effective: April 1, 2026

(Do not alter or modify this form without written permission from the City Administrator)

The total amount budgeted for FY26 is \$13,549.00. It is anticipated that 100% of funds will be spent as specified in the vendor's RFP. The amount of \$13,549.00 can be justified by the vendor's RFP tabulation.

BUDGETED EXPENDITURE? YES NO IF NO, PLEASE EXPLAIN:

Dept.	Name of Account	Account Number	Grant CODE	Amount
	Printing & Publishing	591-545.200-900.000		\$13,549.00
FY26 GRAND TOTAL				\$13,549.00

WHEN APPLICABLE, IF MORE THAN ONE (1) YEAR, PLEASE ESTIMATE TOTAL AMOUNT FOR EACH BUDGET YEAR: (This will depend on the term of the bid proposal)

BUDGET YEAR 1: _____
 BUDGET YEAR 2: _____
 BUDGET YEAR 3: _____

OTHER IMPLICATIONS (i.e., collective bargaining).. _____

PRE-ENCUMBERED? YES NO REQUISITION NO: _____

ACCOUNTING APPROVAL: Yolanda Gray
Yolanda Gray (May 18, 2026 09:42:14 EDT) Date: _____

WILL YOUR DEPARTMENT NEED A CONTRACT? YES NO

Section 5. RESOLUTION DEFENSE TEAM..

(Place the names of those who can defend this resolution at City Council)

	NAME	PHONE NUMBER
1	Scott Dungee	
2	Yolanda Gray	
3		
4		



STAFF REVIEW FORM

Effective: April 1, 2026

(Do not alter or modify this form without written permission from the City Administrator)

STAFF RECOMMENDATION: (PLEASE SELECT): APPROVED NOT APPROVED

DEPARTMENT HEAD SIGNATURE: Scott Dungee
Scott Dungee (May 18, 2026 09:49:35 EDT)
(Name, Title)

ADMINISTRATION APPROVAL:
(\$20,000 or above spending authorizations)

Section 6. VENDOR EVALUATION..

Business Title:	Print Comm	Vendor ID:	00000000779
Review Period:	6/1/26-7/30/26	Department:	DPW/Utilities
Project Name:	Five (5) Year Printing/Mailing CCR Water Quality Reports	Project Type:	Printing

Vendor Goals:

Print Comm will print and mail requested reports during a five (5) year agreement in a timely manner.

	1 = Poor	2 = Fair	3 = Sufficient	4 = Good	5 = Excellent
Job Knowledge:	<input type="checkbox"/>	<input type="checkbox"/>	<input type="checkbox"/>	<input type="checkbox"/>	<input checked="" type="checkbox"/>
Work Quality:	<input type="checkbox"/>	<input type="checkbox"/>	<input type="checkbox"/>	<input type="checkbox"/>	<input checked="" type="checkbox"/>
Timeliness:	<input type="checkbox"/>	<input type="checkbox"/>	<input type="checkbox"/>	<input type="checkbox"/>	<input checked="" type="checkbox"/>
Compliance with Contract:	<input type="checkbox"/>	<input type="checkbox"/>	<input type="checkbox"/>	<input type="checkbox"/>	<input checked="" type="checkbox"/>
Warranty (If Product):	<input type="checkbox"/>	<input type="checkbox"/>	<input type="checkbox"/>	<input type="checkbox"/>	<input type="checkbox"/>
Responsiveness:	<input type="checkbox"/>	<input type="checkbox"/>	<input type="checkbox"/>	<input type="checkbox"/>	<input checked="" type="checkbox"/>
Cost Effectiveness:	<input type="checkbox"/>	<input type="checkbox"/>	<input type="checkbox"/>	<input type="checkbox"/>	<input checked="" type="checkbox"/>
Dependability:	<input type="checkbox"/>	<input type="checkbox"/>	<input type="checkbox"/>	<input type="checkbox"/>	<input checked="" type="checkbox"/>
Total Performance:	<input type="checkbox"/>	<input type="checkbox"/>	<input type="checkbox"/>	<input type="checkbox"/>	<input checked="" type="checkbox"/>
Overall Rating:	<input type="checkbox"/>	<input type="checkbox"/>	<input type="checkbox"/>	<input type="checkbox"/>	<input checked="" type="checkbox"/>



STAFF REVIEW FORM

Effective: April 1, 2026

(Do not alter or modify this form without written permission from the City Administrator)

DEFECTS (IF ANY): IF CHECKED, PLEASE EXPLAIN:

Performance / Other Comments:

Print Comm has provided printing services for over ten (10) years. During this tenure the staff has been professional, produced quality reports as requested and met deadlines before the due date.

REVIEWER'S SIGNATURE: _____

Date: _____

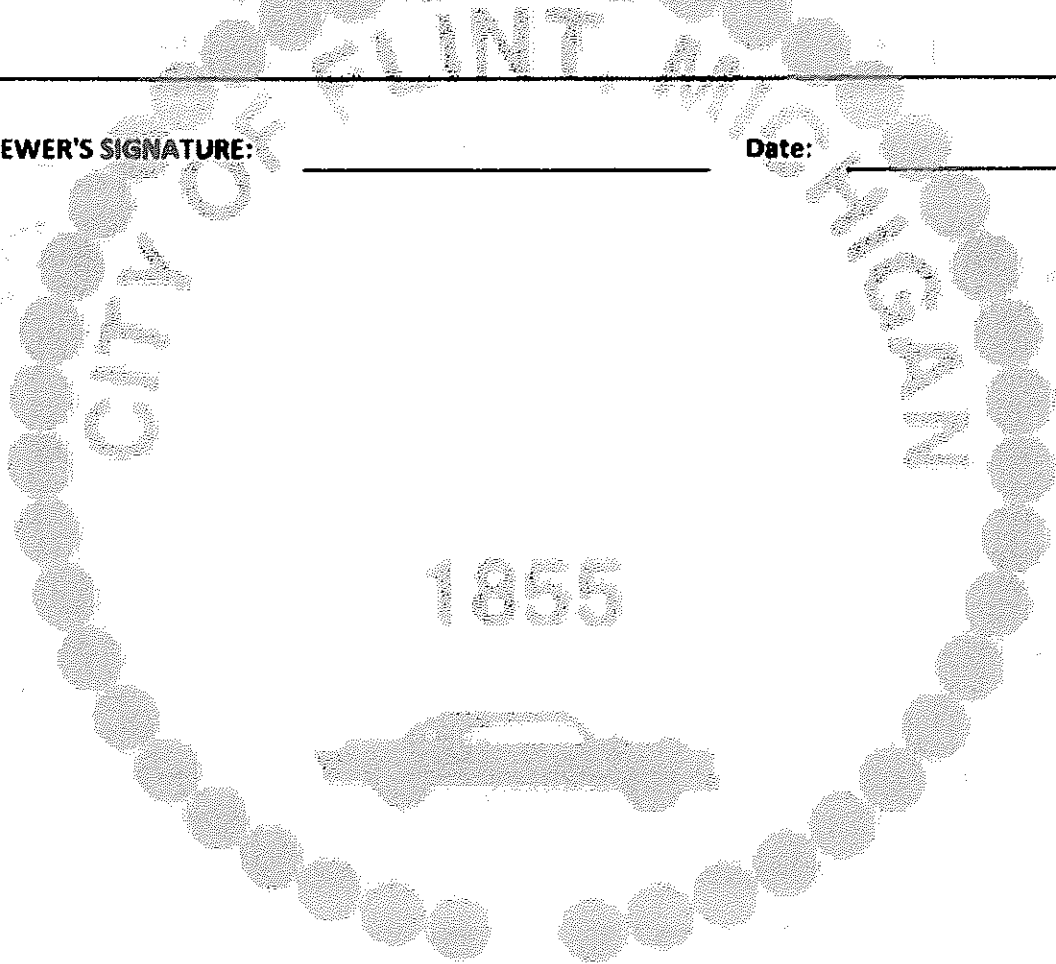

CITY OF FLINT, MICHIGAN
REQUEST FOR PROPOSALS

PROJECT NAME: Five (5) Year Printing , Mailing , Customer Confidence Report (CCR)

Years 2026-2030

Vendor will utilize the City's water customer address file for printing and mailing of approximately 29,000 - 34,000 reports as required by Environmental, Great Lakes, and Energy (EGLE).

Vendor will be required to print an additional 1,000 copies of the report to be delivered to the City's Water Plant.

Option 1 --

Report is printed on 11 x 17 size paper

Information printed in landscape format on front and back of paper

Folded with mailing information on upper front panel of document

Report is folded again to create an 8 1/2 x 5 1/2 mailer

80# Gloss Text paper stock

Inkjet addressed

Tabbing applied where required

Sorted, trayed and prepared for USPS entry

Additional Notes:

- **Vendor to provide PDF proof for approval prior to production**
- **Vendor is responsible for mailers to meet USPS mailing requirements**
- **Bar coded discount for each piece. Cass certification is required.**
- **Mailer has to be printed and mailed during the last week of June and December each year during the contract ending period.**

Option 2 –

- Flat Size: 25.5" x 22"
- Folded Size: 8.5" x 5.5" (final mail size)
- Total Panels: 12 panels (equivalent to twelve 8.5" x 11" pages)
- Printed 4/4 (full color both sides) with bleeds
- 80# Gloss Text paper stock
- Multi-panel fold down to final 8.5" x 5.5" self-mailer
- Designed to remain one continuous sheet (no stitching or binding required)
- Piece is designed to mail at USPS Presorted Standard Mail letter rate (Non-Profit)
- Final folded size of 8.5" x 5.5" qualifies as a machinable letter
- A designated mailing panel must be incorporated into the artwork
 - When folded, the mailing panel will appear in the lower right-hand corner of the mail piece, aligned along the folded edges
 - Placement should mirror prior Option 1 CCR version to ensure compliance with USPS addressing and barcode requirements
 - Inkjet addressed
 - Tabbing applied where required
 - Sorted, trayed, and prepared for USPS entry
- Designed to qualify for USPS Non-Profit Presorted Standard Mail letter rates

Additional Notes:

- Vendor to provide PDF proof for approval prior to production
- Vendor is responsible for mailers to meet USPS mailing requirements
- Mailer has to be printed and mailed during the last week of June and December each year during the contract ending period.

Option 1

<i>Services Performed</i>	<i>Year 1 Cost June/December 2026</i>	<i>Year 2 Cost June/December 2027</i>	<i>Year 3 Cost June/December 2028</i>	<i>Year 4 Cost June/December 2029</i>	<i>Year 5 Cost June/December 2030</i>
<i>Printing of mailer approximately 35,000 as requested</i>	\$3,640.00	\$3,822.00	\$4,013.00	\$4,214.00	\$4,425.00
<i>Bulk barcoded mailing with postage for approximately 34,000</i>	\$9,909.00	\$10,405.00	\$10,925.00	\$11,471.00	\$12,045.00
<i>Total</i>	\$13,549.00	\$14,227.00	\$14,938.00	\$15,685.00	\$16,470.00

Option 2

<i>Services Performed</i>	<i>Year 1 Cost June/December 2026</i>	<i>Year 2 Cost June/December 2027</i>	<i>Year 3 Cost June/December 2028</i>	<i>Year 4 Cost June/December 2029</i>	<i>Year 5 Cost June/December 2030</i>
<i>Printing of mailer approximately 35,000 as requested</i>	\$10,570.00	\$11,099.00	\$11,654.00	\$12,367.00	\$12,985.00
<i>Bulk barcoded mailing with postage for approximately 34,000</i>	\$10,419.00	\$10,940.00	\$11,487.00	\$12,061.00	\$12,664.00
<i>Total</i>	\$20,989.00	\$22,039.00	\$23,141.00	\$24,428.00	\$25,649.00



Department of Finance - Treasury

Sheldon Neesley
Mayor

Clyde Edwards
City Administrator

Good Standing Certification

Applicant and/or Business Clearance

All applicants for City of Flint funded programs, including federal programs, must remain current and not in default on any obligations related to taxes, fines, penalties, water service, licenses or other forms of penalties.

APPLICANT NAME: Print Comm
HOME ADDRESS: 3040 S. Dye Road, Flint, MI 48507
DBA: Marketing Impact Inc
BUSINESS ADDRESS: 3040 S. Dye Road, Flint, MI 48507

Please include addresses of all properties in the name of other current and/or former businesses, parent company, subsidiaries and/or divisions. Also, please include all former names used while conducting business with the City.

PLEASE CHECK THE FOLLOWING DIVISIONS FOR THE STATUS OF CURRENT AND DELINQUENT OBLIGATIONS OWED TO THE CITY OF FLINT. PLEASE CIRCLE THE APPROPRIATE RESPONSE FOR EACH DIVISION.

Please check the following divisions for the status of current and delinquent obligations owed to the City of Flint. Please circle the appropriate response for each division.

WATER DIV.	CURRENT	DELINQUENT	<i>No water acct</i>
PROPERTY TAXES DIV.	CURRENT	DELINQUENT	<i>No Prop tax located</i>
INCOME TAX DIV.	CURRENT	DELINQUENT	<i>No city of Flint income</i>
ENFORCEMENT	CURRENT	DELINQUENT	<i>tax record</i>
MR	CURRENT	DELINQUENT	<i>No mr located</i>

If delinquencies exist, please indicate the date, type and amount of obligation:

City Staff Person and Date

Maisha Lambert 5/13/2026
City of Flint Customer Serv. Representative and Date



Home

Search

Records

Business Search

As of 5/12/2026:

Business Filings are processed through 05/10/2026

Renewals and Restorations (for entities returning to good standing) are processed through 05/10/2026.

To file a document or annual report/statement for an existing entity, search for the entity, select Request Access from the slide-out drawer, complete the questions, refresh the webpage, and select File Subsequent Document or File Annual Report/Statement.

The same process applies to order certificates and copies.

You must be logged in to file documents or order certificates and copies. Click on the Login button in the top right. If you do not have an account, create one. The credentials from the previous system did not transfer to this system.

Business Search Info:

marketing impact

Advanced

Results: 3

Name	Filing Date	Status	AR Standing	Entity
MARKETING IMPACT, INC.	11/26/1985	Dissolved Operation of Law	Not Good	Dom Profit Corp
PRINTCOMM INC. <i>Matched Names: MARKETING IMPACT</i>	06/01/1966	Active	Good	Dom Profit Corp
MARKETING IMPACT, INC. <i>Matched Names: MARKETING IMPACT</i>	05/13/1994	Dissolved Operation of Law	Not Good	Dom Profit Corp

RI 2929
MICHIGAN

Entity Name	PRINTCOMM INC.
Prior Names	FLINT ROTARY PRESS, INC.
Identification #	800021720
Jurisdiction	Michigan
Entity Type	Domestic Profit Corporation
Entity Status	Active
AR Standing	Good
Common Share	50000
AR Due Date	05/15/2027
Initial Filing Date	06/01/1966
Last Report with Officers and Directors	2026
President Agent Name	KEVIN E. NAUGHTON
Registered Office Street Address	3040 S. DYE RD., FLINT, MI 48507
Registered Office Mailing Address	3040 S. DYE RD., FLINT, MI 48507
President Name & Address	KEVIN E. NAUGHTON 2929 DAVISON RD, FLINT, MI 48506
Secretary Name & Address	KEVIN E. NAUGHTON 2929 DAVISON RD, FLINT, MI 48506
Treasurer Name & Address	KEVIN E. NAUGHTON 2929 DAVISON RD, FLINT, MI 48506
Directors Name & Address	KEVIN E. NAUGHTON 2929 DAVISON RD, FLINT, MI 48506

View History & Filings

Assumed Names

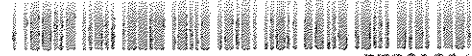

27991094



STATE OF MICHIGAN
CSCL/CD- 2500 - DOMESTIC PROFIT
CORPORATION ANNUAL REPORT

Corporations Division Administrator

FILED

Doc #: 27991094

Filed Date: 2/2/2026

C0666-9503 02/02/2026 Received by Michigan Corporations Division

DEPARTMENT OF LICENSING AND REGULATORY AFFAIRS PROFIT CORPORATION ANNUAL REPORT
Required by Section 911, Act 284, Public Act of 1972

Corporation Information

The present name of the corporation is: PRINTCOMM INC.
The identification number assigned by the Bureau is: 800021720
Annual Report Filing Year: 2026

On behalf of the corporation, I certify that no changes have occurred in required information since the previously filed report.

The name of the resident agent at the registered office is:

KEVIN E. NAUGHTON

Address

3040 S. DYE RD., FLINT, MI 48507

Mailing Address

3040 S. DYE RD., FLINT, MI 48507

Purpose

No changes were selected for this annual report.

Officers and Directors

Current officers and directors are listed below:

Title	Full Name	Address
President	KEVIN E. NAUGHTON	2929 DAVISON RD FLINT, MI 48506
Secretary	KEVIN E. NAUGHTON	2929 DAVISON RD FLINT, MI 48506
Treasurer	KEVIN E. NAUGHTON	2929 DAVISON RD FLINT, MI 48506
Director	KEVIN E. NAUGHTON	2929 DAVISON RD FLINT, MI 48506

Attestations

I understand that the information I enter into the online system is public information and will appear online and on copy requests exactly as I enter it into the system.

I have been authorized by the business entity to file this document online.

I, HEREBY SWEAR AND/OR AFFIRM, under penalty of law, including criminal prosecution, that the facts contained in this document are true. I certify that I am signing this document as the person(s) whose signature is required, or as an agent of the person(s) whose signature is required, who has authorized me to place his/her signature on this document.

Signature

*Self**DeAnna Schillag**02/02/2026*

Signer's Capacity

Sign Here

Date



Search (e.g. 1558-922927)

Filter By

- All Products
- Contracting
- National Institutes
- Early Adopters
- Federal Agency
- Open Administrations

Advanced Search

For more information on how to search, please visit our help page.

Help page

Keyword Search Search Filter

- Any Words
- All Words
- Exact Phrase

Federal Organizations

Status

- Active
- Inactive

No matches found

We couldn't find a match for your search criteria.

Please try another search or go back to previous results.

Go Back

260214

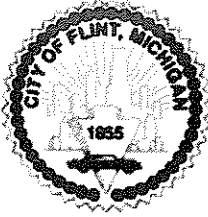

RESOLUTION NO.: _____

PRESENTED: 6-17-2026

ADOPTED: _____

BY THE CITY ADMINISTRATOR:

RESOLUTION AUTHORIZING \$21,000 CHANGE ORDER FOR LEAD-BASED PAINT ABATEMENT

WHEREAS, The Division of Purchases & Supplies previously solicited proposals for Licensed Lead Provider Services for the Office of Public Health, Lead Based Paint Hazard Control Division; and

WHEREAS, The Division of Lead Based Paint Hazard control awarded a qualified vendor, Lake Star Construction Services, inc. Detroit, MI, the proposal at a requested FY23 cost of \$197,480.00. for Lake Star to conduct lead abatement services and Healthy Homes repairs of all lead hazards on (11) units within the city;

WHEREAS, Additional funding in the amount of \$21,000 is required to complete the final two units under the original scope of work; and

WHEREAS, Funding is to come from the following account:

Account Number	Account Name / Grant Code	Amount
287-612.018-801.000	Professional Services/FUSDT- CSLFRF	\$21,000

IT IS RESOLVED, that the appropriate City officials are hereby authorized to amend its contract with Lake Star Construction Services, Inc. for Lead Remediation Services and increase the contracted price for services in an amount not to exceed \$21,000.00.

APPROVED AS TO FORM:

Joanne Gurley
Joanne Gurley, City Attorney
06/05/2026

APPROVED AS TO FINANCE:

Phillip Moore
Phillip Moore (Jun 8, 2026 15:00:17 EDT)
Phillip Moore, Chief Financial Officer

FOR THE CITY OF FLINT:

Clyde Edwards
Clyde Edwards/ A0603 (Jun 8, 2026 15:25:44 EDT)
Clyde Edwards, City Administrator

APPROVED BY CITY COUNCIL:

Lake Star Construction Services Outline Timeline

- *12/15/2023* The contract was signed by all parties to complete 11 homes within Flint. All addresses had all windows, exterior doors replaced, and any exterior exposed walls scraped and painted for removal of lead hazards.
- *2/27/2024 – 3/8/2024* work started and was completed with one change order **\$6,500** for a bathroom demo and replacement of LVT flooring and a new tub with surround. The Invoice was received on 3/18/2024. (**Westcombe/1788/P.O.# 24-006885**)
 - The change order was necessary due to the condition of the tub surround identified after the bathroom demolition. Originally, everything was tiled, and there was no greenboard behind the tile to support the new tub surround.
- *2/19/2024 – 3/15/2024* work started and was completed with one change order **\$9,600** for the abatement of exterior fascia and upper trim around the whole house. The invoice was received on 3/26/2024. (**Stratford/1795/ PO# 24-006885**)
 - The reason for the change order was the condition of the exterior upper trim when the contractor began the work. Upon inspection by the State inspector, it was discovered that the upper trim was covered with vinyl and was missing once the work commenced. Additionally, lead paint was present under all exposed areas.
- *3/4/2024 – 3/29/2024* work started and was completed with one change order **\$2,400** for Pest Control, prior to any work being completed home had been infested with bed bugs, roaches, and mice. The invoice was received on 3/26/2024 and on this day accounting had an error and paid this invoice twice - \$22,590.00. which was subtracted from the next invoice **#1800 PO# 24-006885 (E. Lyndon/1790/PO#24-006885)**

- The change order was necessitated by a severe pest infestation, making it impossible for contractors to proceed with any work. The homeowner was already relocated.

- *3/11/2024 – 3/29/2024* work started and was completed with one change order **\$2,500** for additional cleaning and to replace a door that was missed. The invoice was received on 4/23/2024, and it was reduced -22,590.00 due to overpayment for a previous house. **(Nobert/1800/PO# 24-006885)**
 - This Change Order was issued due to an error by the LBPHC Office, which resulted in a lead hazard door being excluded from the scope of work. As a result, the home required a new cleaning and clearance from the state after the door was replaced.

**LEAD ABATEMENT CONTRACT BETWEEN THE CITY OF FLINT
AND LAKE STAR CONSTRUCTION SERVICES**

This agreement (hereinafter "Agreement") is entered into between the City of Flint, a municipal corporation (hereinafter "City), 1101 S. Saginaw Street, Flint, MI 48502, and Lake Star Construction Services INC (hereinafter "Lake Star"), 440 Burroughs Ste. 133 Detroit, MI 48202 which shall be collectively referred to herein as the "Parties".

WHEREAS, in November 2021, the City of Flint was awarded grant number: MILHB0776-21, for \$2,283,960.00 The funding is allocated as follows: \$1,883,960 in Lead Based Paint Hazard Reduction grant program funding and \$400,000 in Healthy Homes Supplemental funding (Performance period January 1, 2023 -December 31, 2025);

WHEREAS, the primary strategy of the City of Flint Lead-Based Paint Hazard Control Program (COF LBPHC Program) will focus on elimination of lead hazards in 70 eligible housing units of target housing, including 12 rental units and 58 owner occupied housing units.

WHEREAS, Lake Star is currently the agency will perform Lead Based Paint Abatement work on identified units.

WHEREAS, Lake Star's mission is to remove and abate any lead hazards in homes by using interim and permanent control measures

WHEREAS, Lake Star will enter a performance-based MOU over the duration of the grant program pertaining to Lead Abatement contractual work on homes in the City of Flint.

Duties of Lake Star with the Lead Based Paint Hazard control program for 11 units within the City of Flint Provide lead abatement services as listed in the scope of work for LI/RA

1. **Duties of the City:** The City will endeavor to complete the following deliverables in accordance with the timeline and scope described in this memorandum and subject to the timely provision of relevant information, data, and connections to Lake Star.
 - a. The City shall provide funding in the amount of \$431,467 to Lake Star. Lake Star shall provide a detailed invoice to the City at the end of each month and the City will pay such invoice within thirty (30) days of receipt of the invoice.
 - b. Assign a Program Director and Program Manager, who will be a City employee, who will be responsible for the following:
 - i. Quarterly reports to HUD
 - ii. Managing the Budget
 - iii. Organize/facilitate meetings that pertain to the grant, ensuring appropriate Lake Star staff is invited to attend
 - iv. Visit work sites
 - v. Handle applications/ approvals and denials

2. **Effective Date:** This Agreement shall not become effective until signed by all parties. This agreement is effective November 20, 2023 through December 31, 2025.
3. **Compliance with Laws and Regulation:** The Parties agree to comply with federal, state, and local laws, regulations and policies (including those regarding the expenditure of federal funding) in the performance of this Agreement.
4. **Applicable Law:** This Agreement and all related disputes shall be governed by and interpreted in accordance with the laws of the State of Michigan.
5. **Arbitration:** Lake Star agrees that for all claims, disputes, and other matters arising out of or relating to this agreement, Lake Star must request the City's consent to arbitrate within 30 days from the date the Lake Star knows or should have known the facts giving rise to the claim, dispute or question.
 - a. Notice of a request for arbitration must be submitted in writing by certified mail or personal service upon the Chief Legal Officer.
 - b. Within 60 days from the date a request for arbitration is received by the City, the City shall inform Lake Star whether it agrees to arbitrate. If the City does not consent, Lake Star may proceed with an action in a court of competent jurisdiction within the State of Michigan. If the City does consent, then within 30 days of the consent each party shall submit to the other the name of one person to serve as an arbitrator. The two arbitrators together shall then select a third person, the three together shall then serve as a panel in all proceedings. Any unanimous decision of the three arbitrators shall be a final binding decision. The City's failure to respond to a timely, conforming request for arbitration is deemed consent to arbitration.
 - c. The costs of the arbitration shall be split and borne equally between the parties and such costs are not subject to shifting by the arbitrator.
 - d. Lake Star's failure to comply with any portion (including timeliness) of this provision shall be deemed a permanent waiver and forfeiture of the claim, dispute, or question.
 - e. This provision shall survive the expiration or termination of this Agreement in perpetuity.
6. **Termination:** This contract may be terminated by either party hereto by submitting a notice of termination to the other party. The City, through its City Administrator, may terminate this agreement upon actual notice to Lake Star. Lake Star may terminate this agreement by providing written notice that shall be effective 30 days from the date it is submitted unless otherwise agreed to by the parties hereto. Lake Star, upon receiving such notice and prorated payment upon termination of this contract shall give to the City all pertinent records, data, and information created up to the date of termination to which the City, under the terms of this contract, is entitled.
7. **Force Majeure:** Neither party shall be responsible for damages or delays caused by Force Majeure or other events beyond the control of the other party and which could not

reasonably have been anticipated or prevented. For purposes of this Agreement, Force Majeure includes, but is not limited to, adverse weather conditions, floods, epidemics, war, riot, strikes, lockouts, and other industrial disturbances; unknown site conditions, accidents, sabotage, fire, and acts of God. Should Force Majeure occur, the parties shall mutually agree on the terms and conditions upon which the services may continue. Lake Star acknowledges that the Country is in the middle of a COVID-19 pandemic and agrees that Lake Star and its subcontractors will comply with Federal, State of Michigan Executive Orders, Local guidance, CDC, OSHA, MIOSHA, and other regulatory guidelines to mitigate risk and exposure to COVID-19.

8. **Good Standing:** Lake Star must remain current and not be in default of any obligations due the City of Flint, including the payment of taxes, fines, penalties, licenses, or other monies due the City of Flint. Violations of this clause shall constitute a substantial and material breach of this contract. Such breach shall constitute good cause for the termination of this contract should the City of Flint decide to terminate on such basis.
9. **Indemnification:** To the fullest extent permitted by law, Lake Star agrees to defend, pay on behalf of, indemnify, and hold harmless the City of Flint, its elected and appointed officials, employees and volunteers, and other working on behalf of the City of Flint, against any and all claims, demands, suits, demands for repayment, or losses, including all costs connected therewith, and for any damages which may be asserted, claimed, or recovered against or from the City of Flint, its elected and appointed officials, employees, volunteers or others working on behalf of the City of Flint, by reason of personal injury, including bodily injury or death and/or property damage, including loss of use thereof, which may arise as a result of Lake Star's acts, omissions, faults, and negligence, or that of any of his employees, agents, and representatives in connection with the performance of this Agreement. Should Lake Star fail to indemnify the City in the above-mentioned circumstances, the City may exercise its option to deduct the cost that it incurs from the Agreement price forthwith or may file an action in a court of competent jurisdiction, the costs of which shall be paid by Lake Star. This provision shall survive the termination and/or expiration of this agreement, in perpetuity.
10. **Non-Assignability:** Lake Star shall not assign or transfer any interest in this Agreement without the prior written consent of the City provided, however, that claims for money due or to become due to Lake Star from the City under this Agreement may be assigned to a bank, trust company, or other financial institution without such approval. Notice of any such assignment or transfer shall be furnished promptly to the City.
11. **Non-Disclosure/Confidentiality:** Lake Star agrees that Lake Star will not disclose any such information provided to Lake Star in furtherance of this Agreement, or in any other way make such documents public, without the express written approval of the City or the order of a court of competent jurisdiction.

12. **Non-Discrimination:** Lake Star shall comply with the Elliott Larsen Civil Rights Act, 1976 PA 453, as amended, MCL 37.2101 et seq., the Persons with Disabilities Civil Rights Act, 1976 PA 220, as amended, MCL 37.1101 et seq., and all other federal, state, and local fair employment practices and equal opportunity laws and covenants that it shall not discriminate against any employee or applicant for employment, to be employed in the performance of this Agreement, with respect to his or her hire, tenure, terms, conditions, or privileges of employment, or any matter directly or indirectly related to employment, because of his or her race, religion, color, national origin, age, sex, height, weight, marital status, association with the federal government, or physical or mental disability that is unrelated to the individual's ability to perform the duties of a particular job or position or status with respect to public assistance. A breach of this covenant is a material breach of this Agreement.
13. **Anti-Lobbying:** Lake Star shall not use any of the grant funds awarded in this Agreement for the purpose of lobbying as defined in the State of Michigan's lobbying statute, MCL 4.415(2). "'Lobbying' means communicating directly with an official of the executive branch of state government or an official in the legislative branch of state government for the purpose of influencing legislative or administrative action." Lake Star shall not use any of the grant funds awarded in this Agreement for the purpose of litigation against the State or City. Further, Lake Star agrees to require that language of this assurance be included in the award documents of all sub awards.
14. **Grant Funds:** Grant funds may not be used, directly or indirectly, to purchase, prescribe, or provide marijuana or treatment using marijuana. Treatment in this context includes the treatment of opioid use disorder. Grant funds also cannot be provided to any individual who or organization that provides or permits marijuana use for the purposes of treating substance use or mental disorders. See, e.g., 45 C.F.R. § 75.300(a) (requiring HHS to "ensure that Federal funding is expended . . . in full accordance with U.S. statutory . . . requirements."); 21 U.S.C. §§ 812(c)(10) and 841 (prohibiting the possession, manufacture, sale, purchase or distribution of marijuana). This prohibition does not apply to those providing such treatment in the context of clinical research permitted by the DEA and under an FDA-approved investigational new drug application where the article being evaluated is marijuana or a constituent thereof that is otherwise a banned controlled substance under federal law.
15. **Ethics:** Pursuant to the Flint City Charter §1-602 (I) entitled Notice, every public servant, volunteer and city, Lake Star is to receive training and be provided with a copy of these ethical standards upon passage of this Charter or at the time of appointment and or hire or the commencement of services. (See Attached Flint City Charter §1-602 (I)). Therefore, Lake Star acknowledges receipt of Flint City Charter §1-602 and agrees that Lake Star and its staff shall abide by the terms and participate in any training provided by the City/or update orientation as may be necessary from time to time. Public servants are all persons

employed or otherwise engaged by the corporation of the City of Flint to conduct business on its behalf including but not limited to elected officials, appointed employees, members of boards and commissions, classified employees, and volunteers, in accordance with Flint City Charter §1-602.

16. **Notices:** Notices to the City of Flint shall be deemed sufficient if in writing and mailed, postage prepaid, addressed to **Shelly Green-Sparks and Davina Donahue, City Clerk, City of Flint, 1101 S. Saginaw Street, Flint, Michigan 48502**, or to such other address as may be designated in writing by the City from time to time. Notices to Lake Star shall be deemed sufficient if in writing and mailed, postage prepaid, addressed to 440 Burroughs Ste. 133 Detroit, MI 48202, or to such other address as may be designated in writing by CTI from time to time.
17. **Records Property of City:** All documents, information, reports, and the like prepared or generated by Lake Star as a result of this Agreement shall become the sole property of the City of Flint, and shall be disclosed to the City upon request.
18. **Severability:** In the event that any provision contained herein shall be determined by a court or administrative tribunal to be contrary to a provision of state or federal law or to be unenforceable for any reason, then, to the extent necessary and possible to render the remainder of this Agreement enforceable, such provision may be modified or severed by such court or administrative tribunal so as to, as nearly as possible, carry out the intention of the parties hereto, considering the purpose of the entire Agreement in relation to such provision. The invalidation of one or more terms of this contract shall not affect the validity of the remaining terms.
19. **Whole Agreement:** This Agreement and the documents cited herein embody the entire agreement between the parties. Any additions, deletions, or modifications hereto must be in writing and signed by both parties. This Agreement may be executed by facsimile and in counterparts, all of which, taken together, shall constitute a single agreement.

<SIGNATURES ON NEXT PAGE>

Lake Star Construction Services INC:

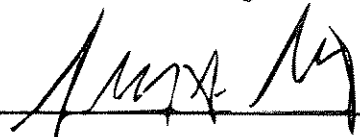

C. Lamar Bailey (Nov 21, 2023 13:22 EST) 11/21/2023
Lamar Bailey, Owner Date

CITY OF FLINT, a Michigan Municipal Corp.:

Sheldon A. Neeley (Nov 21, 2023 13:27 EST) 12/15/23
Sheldon A. Neeley, Mayor Date

CLYDE D EDWARDS
CLYDE D EDWARDS (Nov 21, 2023 13:27 EST) 11/21/2023
Clyde Edwards, City Administrator Date

APPROVED AS TO FORM:

William Kim (Nov 21, 2023 13:24 EST) 11/21/2023
William Kim, Chief Legal Officer Date



LAKE STAR CONSTRUCTION SERVICES, INC.

Unique Entity ID N2EMYPAAANX35	CAGE / NCAGE 9GKC29	Purpose of Registration All Awards
Registration Status Active Registration	Expiration Date Dec 8, 2026	
Physical Address 17800 Woodward AVE STE 1 Detroit, Michigan 48203-2352 United States	Mailing Address 440 Burroughs Suite 133 Detroit, Michigan 48202-3449 United States	

Business Information

Doing Business as (blank)	Division Name (blank)	Division Number (blank)
Congressional District Michigan 13	State / Country of Incorporation Michigan / United States	URL www.lakestarconstruction.net

Registration Dates

Activation Date Dec 10, 2025	Submission Date Dec 8, 2025	Initial Registration Date Feb 1, 2023
--	---------------------------------------	---

Entity Dates

Entity Start Date May 17, 2013	Fiscal Year End Close Date Dec 31
--	---

Immediate Owner

CAGE (blank)	Legal Business Name (blank)
------------------------	---------------------------------------

Highest Level Owner

CAGE (blank)	Legal Business Name (blank)
------------------------	---------------------------------------

Executive Compensation

Registrants in the System for Award Management (SAM) respond to the Executive Compensation questions in accordance with Section 6202 of P.L. 110-252, amending the Federal Funding Accountability and Transparency Act (P.L. 109-282). This information is not displayed in SAM. It is sent to USAspending.gov for display in association with an eligible award. Maintaining an active registration in SAM demonstrates the registrant responded to the questions.

Proceedings Questions

Registrants in the System for Award Management (SAM.gov) respond to proceedings questions in accordance with FAR 52.209-7, FAR 52.209-9, or 2. C.F.R. 200 Appendix XII. Their responses are displayed in the responsibility/qualification section of SAM.gov. Maintaining an active registration in SAM.gov demonstrates the registrant responded to the proceedings questions.

Exclusion Summary

Active Exclusions Records?

N

SAM Search Authorization

I authorize my entity's non-sensitive information to be displayed in SAM public search results:

Yes

Business Types

Entity Structure Corporate Entity (Not Tax Exempt)	Entity Type Business or Organization	Organization Factors (blank)
Profit Structure For Profit Organization		

Socio-Economic Types

Minority-Owned Business
Self Certified Small Disadvantaged Business
DOT Certified DBE
Black American Owned

Check the registrant's Reqs & Certs, if present, under FAR 52.212-3 or FAR 52.219-1 to determine if the entity is an SBA-certified HUBZone small business concern. Additional small business information may be found in the SBA's Dynamic Small Business Search if the entity completed the SBA supplemental pages during registration.

Financial Information

Accepts Credit Card Payments Debt Subject To Offset
No **Yes**

EFT Indicator CAGE Code
0000 **9GK29**

Points of Contact

Electronic Business

☒ **440 BURROUGHS, Suite 133**
Charles L Bailey **Detroit, Michigan 48202**
 United States

Government Business

☒ **440 Burroughs STE. 133**
Charles L Bailey **Detroit, Michigan 48202**
 United States

Service Classifications

NAICS Codes

Primary	NAICS Codes	NAICS Title
Yes	236118	Residential Remodelers

Disaster Response

This entity does not appear in the disaster response registry.



CERTIFICATE OF LIABILITY INSURANCE

DATE (MM/DD/YYYY)
04/27/2026

THIS CERTIFICATE IS ISSUED AS A MATTER OF INFORMATION ONLY AND CONFERS NO RIGHTS UPON THE CERTIFICATE HOLDER. THIS CERTIFICATE DOES NOT AFFIRMATIVELY OR NEGATIVELY AMEND, EXTEND OR ALTER THE COVERAGE AFFORDED BY THE POLICIES BELOW. THIS CERTIFICATE OF INSURANCE DOES NOT CONSTITUTE A CONTRACT BETWEEN THE ISSUING INSURER(S), AUTHORIZED REPRESENTATIVE OR PRODUCER, AND THE CERTIFICATE HOLDER.

IMPORTANT: If the certificate holder is an ADDITIONAL INSURED, the policy(ies) must be endorsed. If SUBROGATION IS WAIVED, subject to the terms and conditions of the policy, certain policies may require an endorsement. A statement on this certificate does not confer rights to the certificate holder in lieu of such endorsement(s).

PRODUCER Next First Insurance Agency, Inc. PO Box 60787 Palo Alto, CA 94306		CONTACT NAME: PHONE (A/C, No. Ext): (855) 222-5919 FAX (A/C, No.): E-MAIL: ADDRESS:																									
INSURED LAKE STAR CONSTRUCTION SERVICES INC 440 BURROUGHS SUITE 133 DETROIT, MI 48202		INSURER(S) AFFORDING COVERAGE <table border="0"> <tr> <td>INSURER A:</td> <td>State National Insurance Company, Inc.</td> <td>NARC #</td> <td>12831</td> </tr> <tr> <td>INSURER B:</td> <td>Travelers</td> <td></td> <td>25666</td> </tr> <tr> <td>INSURER C:</td> <td>National Indemnity</td> <td></td> <td>20087</td> </tr> <tr> <td>INSURER D:</td> <td>Hartford Fire Insurance Company</td> <td></td> <td>19882</td> </tr> <tr> <td>INSURER E:</td> <td></td> <td></td> <td></td> </tr> <tr> <td>INSURER F:</td> <td></td> <td></td> <td></td> </tr> </table>		INSURER A:	State National Insurance Company, Inc.	NARC #	12831	INSURER B:	Travelers		25666	INSURER C:	National Indemnity		20087	INSURER D:	Hartford Fire Insurance Company		19882	INSURER E:				INSURER F:			
INSURER A:	State National Insurance Company, Inc.	NARC #	12831																								
INSURER B:	Travelers		25666																								
INSURER C:	National Indemnity		20087																								
INSURER D:	Hartford Fire Insurance Company		19882																								
INSURER E:																											
INSURER F:																											

COVERAGES CERTIFICATE NUMBER: REVISION NUMBER:

THIS IS TO CERTIFY THAT THE POLICIES OF INSURANCE LISTED BELOW HAVE BEEN ISSUED TO THE INSURED NAMED ABOVE FOR THE POLICY PERIOD INDICATED. NOTWITHSTANDING ANY REQUIREMENT, TERM OR CONDITION OF ANY CONTRACT OR OTHER DOCUMENT WITH RESPECT TO WHICH THIS CERTIFICATE MAY BE ISSUED OR MAY PERTAIN, THE INSURANCE AFFORDED BY THE POLICIES DESCRIBED HEREIN IS SUBJECT TO ALL THE TERMS, EXCLUSIONS AND CONDITIONS OF SUCH POLICIES. LIMITS SHOWN MAY HAVE BEEN REDUCED BY PAID CLAIMS.

INSR LTR	TYPE OF INSURANCE	ADOL	SUBR	INSR	WVD	POLICY NUMBER	POLICY EFF (MM/DD/YYYY)	POLICY EXP (MM/DD/YYYY)	LIMITS
A	GENERAL LIABILITY <input checked="" type="checkbox"/> COMMERCIAL GENERAL LIABILITY CLAIMS-MADE <input checked="" type="checkbox"/> OCCUR GEN'L AGGREGATE LIMIT APPLIES PER: POLICY <input checked="" type="checkbox"/> PRO-JECT <input type="checkbox"/> LOC	X	Y			NXTHRLTH43-00-8P	05/20/2025	05/20/2026	EACH OCCURRENCE \$ 1,000,000 DAMAGE TO RENTED (Ea. accident) \$ 100,000 MED EXP (Any one person) \$ 15,000 PERSONAL & ADV INJURY \$ 1,000,000 GENERAL AGGREGATE \$ 2,000,000 PRODUCTS - COMP/OP AGG \$ 2,000,000
C	AUTOMOBILE LIABILITY <input checked="" type="checkbox"/> ANY AUTO <input type="checkbox"/> ALL OWNED AUTOS <input type="checkbox"/> HIRED AUTOS <input checked="" type="checkbox"/> SCHEDULED AUTOS <input checked="" type="checkbox"/> NON-OWNED AUTOS	X	Y			73APG078213-02	06/16/2025	06/29/2026	COMBINED SINGLE LIMIT (Ea. accident) \$ 1,000,000 BODILY INJURY (Per person) \$ BODILY INJURY (Per accident) \$ PROPERTY DAMAGE (Per accident) \$
B	<input checked="" type="checkbox"/> UMBRELLA LIAB <input checked="" type="checkbox"/> EXCESS LIAB CLAIMS-MADE DED RETENTION \$					5211867U	03/26/2026	03/26/2027	EACH OCCURRENCE \$ 2,000,000 AGGREGATE \$ 2,000,000
B	WORKERS COMPENSATION AND EMPLOYERS LIABILITY ANY PROPRIETOR/PARTNER/EXECUTIVE OFFICER/MEMBER EXCLUDED? (Mandatory in NH) If yes, describe under DESCRIPTION OF OPERATIONS below	Y/N	N/A	Y		5211867	03/28/2026	03/28/2027	<input checked="" type="checkbox"/> WC STATUTORY LIMITS <input type="checkbox"/> OTHER E.L. EACH ACCIDENT \$ 500,000 E.L. DISEASE - EA EMPLOYEE \$ 500,000 E.L. DISEASE - POLICY LIMIT \$ 500,000
D	CONTRACTORS POLLUTION LIABILITY					35SBMBC9AKY	02/15/2026	02/15/2027	\$2,000,000 CLAIMS MADE \$2,000,000 aggregate POLICY

DESCRIPTION OF OPERATIONS / LOCATIONS / VEHICLES (Attach ACORD 101, Additional Remarks Schedule, if more space is required)

WHERE REQUIRED BY WRITTEN CONTRACT, CITY OF FLINT IS ADDITIONAL INSURED ON THE GENERAL LIABILITY POLICY WITH RESPECT TO ONGOING AND COMPLETED OPERATIONS PERFORMED BY THE NAMED INSURED. INSURER WILL ENDEAVOR TO MAIL 30 DAYS WRITTEN NOTICE OF CANCELLATION TO THE CERTIFICATE HOLDER; FAILURE TO DO SO WILL IMPOSE NO LIABILITY OF ANY KIND UPON THE INSURER OR ITS AGENTS OR REPRESENTATIVES.

CERTIFICATE HOLDER

CITY OF FLINT
1101 S.SAGINAW STREET
FLINT, MI 48502

CANCELLATION

SHOULD ANY OF THE ABOVE DESCRIBED POLICIES BE CANCELLED BEFORE THE EXPIRATION DATE THEREOF, NOTICE WILL BE DELIVERED IN ACCORDANCE WITH THE POLICY PROVISIONS.

AUTHORIZED REPRESENTATIVE

Ann Ryan

© 1988-2010 ACORD CORPORATION. All rights reserved.



Department of Finance - Treasury

Sheldon Neeley
Mayor

Clyde Edwards
City Administrator

Good Standing Certification

Applicant and/or Business Clearance

All applicants for City of Flint funded programs, including federal programs, must remain current and not in default on any obligations related to taxes, fines, penalties, water service, licenses or other forms of penalties.

APPLICANT NAME: Lake Star Construction Services, Inc

HOME ADDRESS: 440 Burroughs, Ste 133 Detroit, MI 48202

DBA: Lake Star

BUSINESS ADDRESS: 440 Burroughs, Ste 133 Detroit, MI 48202

Please include addresses of all properties in the name of other current and/or former businesses, parent company, subsidiaries and/or divisions. Also, please include all former names used while conducting business with the City

This section to be completed by the Department of Finance - Customer Service Division

Please check the following divisions for the status of current and delinquent obligations owed to the City of Flint. Please circle the appropriate response for each division.

WATER DIV.
PROPERTY TAXES DIV.
INCOME TAX DIV.
ENFORCEMENT
MR

CURRENT
CURRENT
CURRENT
CURRENT
CURRENT

DELINQUENT
DELINQUENT
DELINQUENT
DELINQUENT
DELINQUENT

*No water acct located in
NO bus tax located in
No record of income
tax in name*

If delinquencies exist, please indicate the date, type and amount of obligation:

City Staff Person and Date

Sheldon Neeley 1-29-2026

City of Flint Customer Serv. Representative and Date



Department of Finance - Treasury

**Sheldon Neeley
Mayor**

Good Standing Certification

Applicant and/or Business Clear

All applicants for City of Flint funded programs, including federal programs, must remain current on any obligations related to taxes, fines, penalties, water service, licenses or other forms of payment.

APPLICANT NAME: Lake Star Construction Services, Inc

HOME ADDRESS: 440 Burroughs, Ste 133 Detroit, Mi 48202

DBA: Lake Star

BUSINESS ADDRESS: 440 Burroughs, Ste 133 Detroit, MI 48202

Please include addresses of all properties in the name of other current and/or former business subsidiaries and/or divisions. Also, please include all former names used while conducting business.

This section to be completed by the Department of Finance - Customer Service

Please check the following divisions for the status of current and delinquent obligations owed to the City of Flint. Please circle the appropriate response for each division.

WATER DIV.	CURRENT	DELINQ
PROPERTY TAXES DIV.	CURRENT	DELINQ
INCOME TAX DIV.	CURRENT	DELINQ
ENFORCEMENT	CURRENT	DELINQ
MR	CURRENT	DELINQ

If delinquencies exist, please indicate the date, type and amount of obligations.

Clyde Edwards
City Administrator

rance

rent and not in default on
inalties.

sses, parent company,
business with the City.

Division

d to

IENT
IENT
IENT
IENT
IENT

gation:

City Staff Person and Date

City of Flint Customer

1101 S. Segraw St., FLINT, MICHIGAN 48502 (810) 766



CITY OF FLINT

**** STAFF REVIEW FORM ****

Effective: November 14, 2025

(Do Not Alter or modify this form without written permission from the City Administrator)

TODAY'S DATE: 12/19/2025

BID/PROPOSAL#

AGENDA ITEM TITLE: Resolution authorizing \$21,000 Change Order for Lead-Based Paint Abatement Contract

PREPARED BY: Christian Baldwin

VENDOR NAME: Lake Star Construction, LLC

Section I: BACKGROUND/SUMMARY OF PROPOSED ACTION:

Vendor Compliance (This vendor has been properly vetted and the responses are below):

Federal government	(All documentation current, no violations)	<input checked="" type="checkbox"/> YES	<input type="checkbox"/> NO
State government	(All documentation current, no violations)	<input checked="" type="checkbox"/> YES	<input type="checkbox"/> NO
City of Flint	(All documentation current, no violations)	<input checked="" type="checkbox"/> YES	<input type="checkbox"/> NO

The requesting authority is validating that this vendor has been in full compliance with all past contract provisions and has not violated the terms of any contract with the City of Flint.

NOTE: Preparer MUST include a response to the conditions below:

- **Did we do an assessment of first consideration to internal City of Flint staff and resources (explain)?**
- **Why was this vendor chosen?**
- **What history does this vendor have with the City of Flint?**
- **What steps will be taken to do a post-performance of the vendor?**

1. The City does not employ enough staff with the necessary knowledge, skills and experience to perform the needed lead abatement work.

2. Lake Star submitted a bid in response to RFP P2400520 and was awarded a contract to perform lead abatement work at 11 of 13 homes that were bid on. Contractors must demonstrate experience in working with residents and adhering to deadlines. Additionally, they are required to comply with federal and state laws and to maintain positive relationships with both the City of Flint and the Michigan Department of Health and Human Services. Conducting remediation of identified and documented health and safety hazards that are individualized for each of the housing units selected to receive this work where lead hazard control activities are being completed. During their work, additional work was identified by the contractor as necessary to complete lead based paint remediation and hazard reduction and was submitted as a change order to the scope of work to the program manager who approved the change orders, resulting in an additional \$21,000



CITY OF FLINT

**** STAFF REVIEW FORM ****

Effective: November 14, 2025

(Do Not Alter or modify this form without written permission from the City Administrator)

owed to the contractor. Resolution 230433 authorized the City to enter into contract with Lake Star for this work for an amount not-to-exceed \$197,480, but did not include any additional authorization for contingencies. A resolution to amend 230433 to increase the authorized amount to spend by \$21,000 is required to issue a purchase order and pay the outstanding balance of the change orders.

3. Lake Star Construction has contracted with the City for various projects for lead based paint abatement, roof repair program, and the Choice neighborhoods commercial façade improvements.

4. As described below

******* BELOW DESCRIBE THE VENDOR REVIEW PROCESS (VENDOR EVALUATION METHOD)**

The vendor's performance will be evaluated according to the following criteria:

- 1. Product/Service Quality
- 2. Cost Management
- 3. Delivery & Timeliness
- 4. Service & Support
- 5. Risk Management

Each category will receive a weighted score of 1-5 to calculate an overall classification of the vendor's performance which correlates to a simplified description of the vendor's performance. This evaluation will be kept on file for future reference.

PROCUREMENT (MUST BE SPECIFIED)

Please specify how this vendor was identified: (Check one)

- Sole Source (Please attach sole source statement to requisition)
- Competitive Bid Process (Please attach bid tabulation/documents to requisition)
- Cooperative Contract (MIDeal, Sourcwell, GSA, or other municipality)

*Contract must be attached to your requisition and contract must appear on the vendor's quote for goods/services

- (3) Quotes (please attach all quotes to your requisition)

Section II. PREVIOUS ALLOCATIONS (INCLUDE ALL ACCOUNTS USED FOR THIS PURPOSE)/ PROVIDE RESOLUTION OR CONTRACT INFORMATION THAT APPLIES

Fiscal Year	Account	PO Number	FY PO Amount	FY Expensed	Resolution
2026	296-704.801-963.000	26-008738	\$250,000	\$250,000	250199-T



CITY OF FLINT

**** STAFF REVIEW FORM ****

Effective: November 14, 2025

(Do Not Alter or modify this form without written permission from the City Administrator)

2025	296-721.000-802.000	25-008340	\$74,999	\$74,999	
2024	296-171.711-801.000	24-006885	\$197,480	\$196,950.84	230433
2023	296-171.711-801.000	23-005608	\$809,467	\$761,164	230035
2022		None			

[Empty rectangular box for notes or comments]

Section III.

POSSIBLE BENEFIT TO THE CITY OF FLINT (RESIDENTS AND/OR CITY OPERATIONS) INCLUDE PARTNERSHIPS AND COLLABORATIONS:

Our city is committed to improving living conditions and promoting healthy living. Lead dollars are allocated to remove lead hazards from homes with pregnant individuals or children under six. This approach will ensure a safer and healthier environment for all our residents. It will also strengthen our partnership with HUD and open up more funding opportunities in the future.

Section IV: FINANCIAL IMPLICATIONS:

IF ARPA related Expenditure: YES

Has this request been reviewed by E&Y Firm: YES NO IF NO, PLEASE EXPLAIN:

- NOTE: Accountant MUST include the following information:**
- What is the total amount budgeted for this purpose?
 - What percentage is being spent with this vendor?
 - What is the justification for spending this amount of money with this vendor?
 - What percentage is being spent out of each line item used in this request?
 - List all the known budgeted funds from that line item.



CITY OF FLINT

**** STAFF REVIEW FORM ****

Effective: November 14, 2025

(Do Not Alter or modify this form without written permission from the City Administrator)

1. The total amount budgeted for this purpose is \$24,087.57
2. 87.2% will be spent with Lake Star
3. There are 2 outstanding invoices owed to Lake Star for change orders that were authorized by the program manager, adding an additional \$21,000 to the total contract.
4. The only account used will be 287-612.018-801.000 FUSDT-CSLFRF, which has a total budget in FY26 of \$24,087.57. This request represents 87.2% of the total amount budgeted.
5. Budgeted funds includes:
 Lead based paint abatement: \$21,000
 Blood lead level testing and case management: \$3,087.57
 Total: \$24,087.57.

BUDGETED EXPENDITURE? YES NO IF NO, PLEASE EXPLAIN:

Dept.	Name of Account	Account Number	Grant Code	Amount
Mayor - LBPHC	Professional Services	287-612.018-801.000	FUSDT- CSLFRF	\$21,000.00
		FY26 GRAND TOTAL		\$21,000.00

WHEN APPLICABLE, IF MORE THAN ONE (1) YEAR, PLEASE ESTIMATE TOTAL AMOUNT FOR EACH BUDGET YEAR: (This will depend on the term of the bid proposal)

BUDGET YEAR 1 _____

BUDGET YEAR 2 _____



CITY OF FLINT

**** STAFF REVIEW FORM ****

Effective: November 14, 2025

(Do Not Alter or modify this form without written permission from the City Administrator)

BUDGET YEAR 3 _____

OTHER IMPLICATIONS (i.e., collective bargaining):

PRE-ENCUMBERED? YES NO REQUISITION NO:

ACCOUNTING APPROVAL: Christian Baldwin (Dec 19, 2025 14:26:29 EST) Date: _____

WILL YOUR DEPARTMENT NEED A CONTRACT? YES NO

Section V: RESOLUTION DEFENSE TEAM:

(Place the names of those who can defend this resolution at City Council)

	NAME	PHONE NUMBER
1	Michael Carpenter	810-237-2019
2	Shelly Sparks-Green	810-766-7346 ext. 2049
3	Christian Baldwin	810-766-7266 ext. 2317

STAFF RECOMMENDATION: (PLEASE SELECT): APPROVED NOT APPROVED

DEPARTMENT HEAD SIGNATURE: Michael Carpenter (Dec 19, 2025 12:27:20 MST)
(Name, Title)

ADMINISTRATION APPROVAL: CD_Blwar (Dec 20, 2025 21:00:03 EST)
(\$20,000 or above spending authorizations)

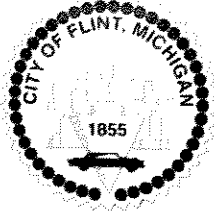

Proposal: 26000513
Tracking: A0658

RESOLUTION NO.: 260215
PRESENTED: 6-17-2026
ADOPTED: _____

BY THE CITY ADMINISTRATOR:

**RESOLUTION AUTHORIZING THE CITY TO ENTER INTO AGREEMENTS
WITH BEATRICE CONSTRUCTION LLC FOR THE PURPOSES OF
ACCESSIBILITY MODIFICATIONS OF THREE SINGLE FAMILY HOMES UNDER
THE MSHDA GRANT NDD-2023-49-MIN**

WHEREAS, In December of 2024, The City Council accepted the award of \$472,000.00 from the Michigan State House Development Authority (MSHDA) for the City’s Occupied Housing Accessibility Rehab Program through MI Neighborhood 1.0 Grant NDD-2023-49-MIN. (Performance Period October 2024-August 31st, 2026). Which was received and approved through resolution 240484-T adopted December 16th, 2024.

WHEREAS, the goal of the Accessibility Rehab program funded from MSHDA’s MI Neighborhood grant, is the successful modification of 19 single family homes throughout the City of Flint, 19 of which have already been identified, processed, vetted, and currently working with the occupants.

WHEREAS, Beatrice Construction, LLC is a licensed and insured construction company, familiar with both this specific project and the type of work expected throughout this contract.

WHEREAS, Beatrice Construction, LLC, through a competitive bid process, placed a bid on five of the 19 properties.

WHEREAS, Beatrice Construction, LLC was selected to perform accessibility modifications for three of the five properties they bid on.

WHEREAS, Beatrice Construction LLC will enter a performance-based contract over the duration of the grant program, providing accessibility rehabs for three of the 19 properties, and will ensure compliance with both City of Flint requirements and MSHDA MI Neighborhood 1.0 compliance.

WHEREAS, Funding is to come from the following account(s):

Account Number	Account Name/Grant Code	Amount
296-704.735-801.000	SMSHD-MICH23	\$84,597.50



RESOLUTION NO.: _____

PRESENTED: _____

ADOPTED: _____

Proposal: 26000513

Tracking: A0658

IT IS RESOLVED, that the appropriate City officials are hereby authorized to award MI Neighborhood 1.0 funding and to enter into contract with Beatrice Construction, LLC for the remainder of the grant period, up to August 31st, 2026 in a total amount not to exceed \$84,597.50 for services relating to their performing of accessibility modifications to three single family homes within the City of Flint as part of the Occupied Housing Accessibility Rehab Program.

APPROVED AS TO FORM:



JoAnne Gurley (Jun 2, 2026 15:20:39 EDT)
Joanne Gurley, City Attorney

APPROVED AS TO FINANCE:



Phillip Moore (Jun 2, 2026 21:42:37 EDT)
Phillip Moore, Chief Financial Officer

FOR THE CITY OF FLINT:



Clyde Edwards/ A0658 (Jun 5, 2026 12:42:38 EDT)
Clyde Edwards, City Administrator

APPROVED BY CITY COUNCIL:



STAFF REVIEW FORM

Effective: April 1, 2026

(Do not alter or modify this form without written permission from the City Administrator)

TODAY'S DATE: June 2nd, 2026

BID PROPOSAL #: 26000513

AGENDA ITEM TITLE: RESOLUTION AUTHORIZING THE CITY TO ENTER INTO AGREEMENTS WITH BEATRICE CONSTRUCTION LLC FOR THE PURPOSES OF ACCESSIBILITY MODIFICATIONS OF THREE SINGLE FAMILY HOMES UNDER THE MSHDA GRANT NDD-2023-49-MIN

PREPARED BY: Shelby Bader- Department of Business and Community Services

VENDOR NAME: Beatrice Construction, LLC

Section 1. BACKGROUND/SUMMARY OF PROPOSED ACTION..

Vendor Compliance (This vendor has been properly vetted and the responses are below) :

Federal gov't	(All documentation current, no violations)	<input checked="" type="checkbox"/> YES	<input type="checkbox"/> NO
State gov't	(All documentation current, no violations)	<input checked="" type="checkbox"/> YES	<input type="checkbox"/> NO
City of Flint	(All documentation current, no violations)	<input checked="" type="checkbox"/> YES	<input type="checkbox"/> NO

The requesting authority is validating that this vendor has been in full compliance with all past contract provisions and has not violated the terms of any contract with the City of Flint.

NOTE: Preparer MUST include a response to the conditions below:

- Did we do an assessment of first consideration to internal City of Flint staff and resources (explain)?
- Why was this vendor chosen?
- What history does this vendor have with the City of Flint?
- What steps will be taken to do a post-performance of the vendor?

No assessment completed as this work cannot be conducted by City of Flint staff.

The Vendor was chosen based upon a competitive bid process, as well as cost reasonableness ensured through assistance from Genesee County Habitat for Humanity.

The vendor has no prior history working with the City of Flint.

Before final payment is issued, the vendor must provided finalized permits, invoices, and other compliance documentation required by both MSHDA and the Department of Business and Community Services for each of the 3 residencies they have worked on.

PROCUREMENT (MUST BE SPECIFIED)

Please specify how this vendor was identified: (Check one)

- Sole Source (Please attach sole source statement to requisition)
- Competitive Bid Process (Please attach bid tabulation/documents to requisition)



STAFF REVIEW FORM

Effective: April 1, 2026

(Do not alter or modify this form without written permission from the City Administrator)

- Cooperative Contract (MIDeal, Sourcewell, GSA, or other municipality)
*Contract must be attached to your requisition and contract must appear on the vendor's quote for goods/services
- (3) Quotes (please attach all quotes to your requisition)

Section 2. PREVIOUS ALLOCATIONS (INCLUDE ALL ACCOUNTS USED FOR THIS PURPOSE)/ PROVIDE RESOLUTION OR CONTRACT INFORMATION THAT APPLIES..

Fiscal Year	Account	PO Number	FY PO Amount	FY Expensed	Resolution
NA					

This vendor has not conducted business with The City of Flint previously.

Section 3. POSSIBLE BENEFIT TO THE CITY OF FLINT (RESIDENTS AND/OR CITY OPERATIONS) INCLUDE PARTNERSHIPS AND COLLABORATIONS..

The benefits to the City of Flint are that 3 of a total 19 low and moderate income residents with accessibility needs, including both renters and homeowners residing in single family homes within the City are going to receive accessibility updates to their home. The other 16 properties will be rehabbed by a different firm.

Partners are the Michigan State Housing Development Authority, through their MI Neighborhood 1.0 program which provided the \$472,000.00 of funding for this project.

Genesee County Habitat for Humanity provided scopes of work to City of Flint staff so that they could use them as a baseline to help bidders during the competitive bid process and ensure cost reasonableness throughout the process.



STAFF REVIEW FORM

Effective: April 1, 2026

(Do not alter or modify this form without written permission from the City Administrator)

Section 4. FINANCIAL IMPLICATIONS..

IF ARPA related Expenditure:

Has this request been reviewed by E&Y Firm: YES NO IF NO, PLEASE EXPLAIN:

This is not affiliated with ARPA.

NOTE: Accountant MUST include the following information:

- What is the total amount budgeted for this purpose?
- What percentage is being spent with this vendor?
- What is the justification for spending this amount of money with this vendor?
- What percentage is being spent out of each line item used in this request?
- List all the known budgeted funds from that line item.

Beatrice Construction, LLC is budgeted 17.92% not to exceed \$84,597.50 of the \$472,000.00 total grant allocation.

\$472,000.00 has been allocated to the City of Flint for this project via the State of Michigan and resolved through council 240484-T adopted 12/16/2024.

Beatrice Construction, LLC is one of two companies who responded with reasonable bids received through our competitive bid process as well as having applicable experience and certifications relevant to this project.

BUDGETED EXPENDITURE? YES NO IF NO, PLEASE EXPLAIN:

Dept.	Name of Account	Account Number	Grant CODE	Amount
DBCS	SMSHD-MICH23	296-704.735-801.000		\$84,597.50
FY26 GRAND TOTAL				\$84,597.50

WHEN APPLICABLE, IF MORE THAN ONE (1) YEAR, PLEASE ESTIMATE TOTAL AMOUNT FOR EACH BUDGET YEAR: (This will depend on the term of the bid proposal)



STAFF REVIEW FORM

Effective: April 1, 2026

(Do not alter or modify this form without written permission from the City Administrator)

BUDGET YEAR 1: \$84,597.50
 BUDGET YEAR 2: NA
 BUDGET YEAR 3: NA

OTHER IMPLICATIONS (i.e., collective bargaining).. These funds must be fully expended by August 31st.

PRE-ENCUMBERED? YES NO REQUISITION NO: _____

ACCOUNTING APPROVAL: Carissa Dotson Date: _____

WILL YOUR DEPARTMENT NEED A CONTRACT? YES NO

Section 5. RESOLUTION DEFENSE TEAM..

(Place the names of those who can defend this resolution at City Council)

	NAME	PHONE NUMBER
1	Roderick Slaughter	(810) 766-7426 x 3019
2	Shelby Bader	810-766-7426 ext. 3009
3	Celeste Lord	810-766-7426 ext. 3031
4		

STAFF RECOMMENDATION: (PLEASE SELECT): APPROVED NOT APPROVED

DEPARTMENT HEAD SIGNATURE: Rod Slaughter Deputy Director

 (Name, Title)

ADMINISTRATION APPROVAL: [Signature]

 Clyde Edwards (Jun 2, 2026 14:23:47 EDT)

Section 6. VENDOR EVALUATION..



STAFF REVIEW FORM

Effective: April 1, 2026

(Do not alter or modify this form without written permission from the City Administrator)

Business Title:

Vendor ID:

Review Period:

Department:

Project Name:

Project Type:

Vendor Goals:

Empty box for Vendor Goals

	1 = Poor	2 = Fair	3 = Sufficient	4 = Good	5 = Excellent
Job Knowledge:	<input type="checkbox"/>	<input type="checkbox"/>	<input type="checkbox"/>	<input type="checkbox"/>	<input type="checkbox"/>
Work Quality:	<input type="checkbox"/>	<input type="checkbox"/>	<input type="checkbox"/>	<input type="checkbox"/>	<input type="checkbox"/>
Timeliness:	<input type="checkbox"/>	<input type="checkbox"/>	<input type="checkbox"/>	<input type="checkbox"/>	<input type="checkbox"/>
Compliance with Contract:	<input type="checkbox"/>	<input type="checkbox"/>	<input type="checkbox"/>	<input type="checkbox"/>	<input type="checkbox"/>
Warranty (If Product):	<input type="checkbox"/>	<input type="checkbox"/>	<input type="checkbox"/>	<input type="checkbox"/>	<input type="checkbox"/>
Responsiveness:	<input type="checkbox"/>	<input type="checkbox"/>	<input type="checkbox"/>	<input type="checkbox"/>	<input type="checkbox"/>
Cost Effectiveness:	<input type="checkbox"/>	<input type="checkbox"/>	<input type="checkbox"/>	<input type="checkbox"/>	<input type="checkbox"/>
Dependability:	<input type="checkbox"/>	<input type="checkbox"/>	<input type="checkbox"/>	<input type="checkbox"/>	<input type="checkbox"/>
Total Performance:	<input type="checkbox"/>	<input type="checkbox"/>	<input type="checkbox"/>	<input type="checkbox"/>	<input type="checkbox"/>
Overall Rating:	<input type="checkbox"/>	<input type="checkbox"/>	<input type="checkbox"/>	<input type="checkbox"/>	<input type="checkbox"/>

DEFECTS (IF ANY): IF CHECKED, PLEASE EXPLAIN:

Empty box for Defects



STAFF REVIEW FORM

Effective: April 1, 2026

(Do not alter or modify this form without written permission from the City Administrator)

Performance / Other Comments:

REVIEWER'S SIGNATURE: _____

Date: _____

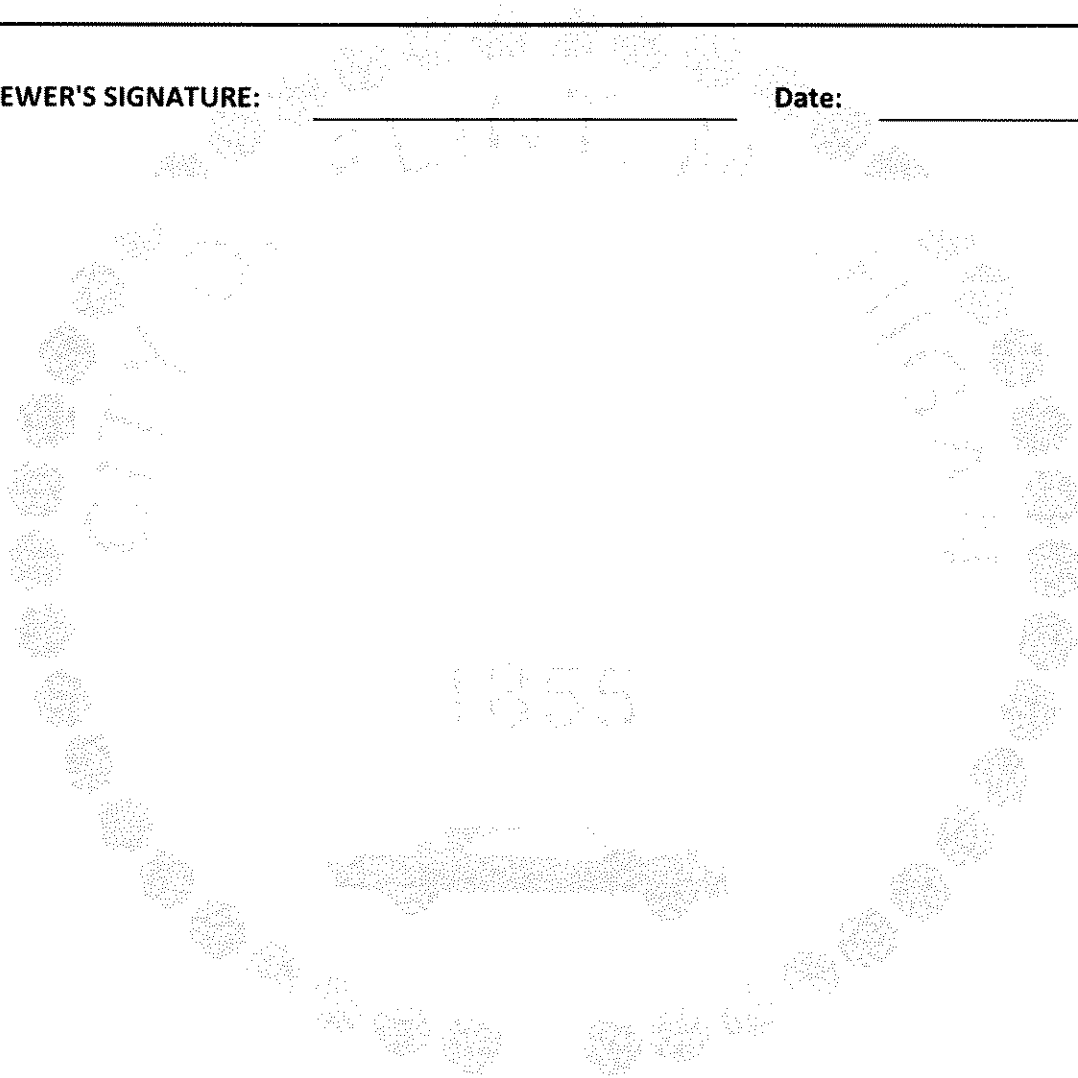

Property Number	Bid	30% Contingency	Property Total
Property 1			
Property 2			
Property 3			
Property 4			
Property 5	\$18,095.00	\$5,428.50	\$23,523.50
Property 6			
Property 7			
Property 8			
Property 9			
Property 10			
Property 11			
Property 12			
Property 13	\$11,340.00	\$3,402.00	\$14,742.00
Property 14			
Property 15			
Property 16			
Property 17			
Property 18	\$35,640.00	\$10,692.00	\$46,332.00
Property 19			
		Beatrice Total	\$84,597.50



SEALED PROPOSALS RECEIVED IN THE DIVISION OF PURCHASES & SUPPLIES
CONSTRUCTION SERVICES FOR SCATTERED SINGLE-FAMILY HOME ADA REHABILITATION
PROPOSAL# 26000513

Approximate Annual Quantities – Not Guaranteed
 Furnish as requested for the period 07/1/26 – 6/30/27

Property #	Blackout Construction LLC, Mt Clemons, MI	Beatrice Construction LLC, Clinton Twp, MI	Servpro, Flint Twp, MI
#1	\$10,571.00	No bid	\$ 13,898.29
#2	\$9,676.00	No bid	\$ 10,578.93
#3	\$14,673.00	No bid	\$ 60,235.08
#4	\$16,580.00	No bid	\$ 79,006.80
#5	\$18,893.00	\$18,095.00	\$ 40,085.63
#6	\$2,500.00	\$12,950.00	\$ 14,873.84
#7	\$12,953.00	No bid	\$ 92,725.51
#8	\$7,220.00	No bid	\$ 16,358.30
#9	\$8,288.00	No bid	\$ 28,963.77
#10	\$15,150.00	No bid	\$ 35,496.92
#11	\$16,790.00	No bid	\$ 94,245.36
#12	\$10,148.00	\$20,069.00	\$ 68,535.05
#13	\$5,141.50	\$11,340.00	\$ 14,390.22
#14	\$12,020.00	No bid	\$ 31,122.00
#15	\$13,238.00	No bid	\$ 28,567.11
#16	\$14,470.00	No bid	\$ 38,825.58
#17	\$7,038.00	No bid	\$

A SPECIAL NOTE FROM THE PURCHASING DIVISION

Bid results posted are before evaluation team review and award recommendation.



			16,192.28
#18	\$38,700.00	\$35,640.00	\$ 61,474.07
#19	\$4,138.00	No bid	\$ 20,348.15
GRAND TOTAL	\$238,187.50	\$98,094.00 (for 5 properties only)	\$ 765,922.89
Notes			**Original total was quoted \$771,288.43. The yellow highlighted tab reflects the actual total.

A SPECIAL NOTE FROM THE PURCHASING DIVISION

Bid results posted are before evaluation team review and award recommendation.

Sheldon Neeley
Mayor of Flint

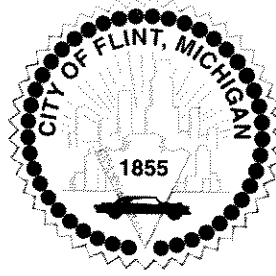

CITY OF FLINT SERVICES AGREEMENT

This agreement (hereinafter "Agreement") by and between the City of Flint, a Michigan Municipal Corporation, 1101 S. Saginaw Street, Flint, MI 48502, hereinafter referred to as the ("City"), and Beatrice Construction, LLC. hereafter referred to as ("Vendor"), and both collectively, the Parties.

The City desires to enter into an agreement for the rehabilitation of 3 Properties as part of the Occupied Accessibility rehab Program funded through Michigan State Housing Development Authority's (MSHDA) MI Neighborhood 1.0 program and the Vendor has agreed to provide the referenced services. **THEREFORE**, the Parties agree as follows:

1. **Applicable Law:** This Agreement and all related disputes shall be governed by and interpreted in accordance with the laws of the State of Michigan.
 2. **Scope of Services:** The Vendor shall provide Accessibility rehabilitation upgrades to 3 single family properties located throughout the City of Flint, utilizing the scopes of services provided in their bid. SEE ATTACHMENT A. Incorporated by Reference for Beatrice Construction, LLC Accessibility Rehab Upgrades \$84,597.50 all documents and attachments.
 3. The Vendor shall ensure that all parties agree on the scope of work prior to any work being completed, and that each individual property has a completed contract between the home owner, the City, and the Contractor.
2. **Compensation:** The City shall reimburse Beatrice Construction, LLC. in an amount Not-To-Exceed (\$84,597.50).
3. **Duties of the City:** The City will endeavor to complete the following deliverables in accordance with the timeline and scope described herein:
 - a. The primary City contact for the Vendor shall be Shelby Bader, Community Development Program Manager in the Community Services Division. sbader@cityofflint.com (810) 386-5068
 - b. Provide any necessary information, forms, assistance in reach residents, and completing obligations under this Agreement and as required by the City;
4. **Term of Agreement:** This Agreement shall commence on June 2nd, 2026 and end on August 31st, 2026. This agreement is in full force and effect for the period specified unless amended by both Parties in writing.
5. **Claims and Disputes:** Vendor agrees that for all claims, disputes, and other matters arising out of or relating to this agreement, Vendor must first request the City's consent to arbitrate. Such a request must be made within 30 days from the date Vendor learns of or should have known the facts giving rise to the claim, dispute or question.
 - a. Notice of a request for arbitration must be submitted in writing by certified mail or personal service upon the City Attorney.

- b. Within 60 days from the date a request for arbitration is received by the City, the City shall inform Vendor whether it agrees to arbitrate. If the City does not consent, Vendor may proceed with an action in a court of competent jurisdiction in Genesee County, Michigan. If the City does consent, then within 30 days of the consent each party shall submit to the other the name of one person to serve as an arbitrator. The two arbitrators together shall then select a third person. The three together shall then serve as a panel in all proceedings. Any unanimous decision of the three arbitrators shall be a final binding decision. The City's failure to respond to a timely, conforming request for arbitration is deemed consent to arbitration.
 - c. The costs of the arbitration shall be split and borne equally between the parties and such costs are not subject to shifting by the arbitrator.
 - d. Vendor's failure to comply with any portion (including timeliness) of this provision shall be deemed a permanent waiver and forfeiture of the claim, dispute, or question.
 - e. This provision shall survive the expiration or termination of this Agreement in perpetuity.
 - f. Any and all arbitration shall be conducted in Genesee County, Michigan.
- 8. Contractual Relationship with Subcontractors:** Nothing contained in this Agreement shall be construed as to automatically create any contractual relationship between the City and any subcontractor or sub-subcontractor of Vendor. And even if subcontractor work is permitted by the City, no subcontract work shall be started prior to the written approval of the subcontractor by the City. The City reserves the right to accept or reject any subcontractor.
- 9. City Income Tax Withholding:** Vendor and any subcontractor engaged in this contract shall withhold from each payment to its employees the City income tax on all of their compensation subject to City tax, after giving effect to exemptions. Such withholding shall be at a rate equal to 1% of all compensation paid to the employee who is a resident of the City of Flint, and ½% of the compensation paid to the employee who is a non-resident of the City of Flint. These taxes shall be held in trust and paid over to the City of Flint in accordance with City ordinances and State law. Any failure to do so shall constitute a material breach of this contract.
- 10. Insurance/Worker's Compensation:** Vendor shall not commence work under this contract until he has procured and provided evidence of the insurance required under this section. All coverage shall be obtained from insurance companies licensed and authorized to do business in the State of Michigan unless otherwise approved by the City's Finance Department. Policies shall be reviewed by the City's Finance Department for completeness and limits of coverage. All coverage shall be with insurance carriers acceptable to the City of Flint. Vendor shall maintain the following insurance coverage for the duration of the contract:
- a. Commercial General Liability coverage of not less than one million dollars (\$1,000,000) combined single limit with the City of Flint, and including all elected and appointed officials, all employees and volunteers, all boards, commissions and/or authorities and their board members, employees, and volunteers, named as "Additional Insureds." This coverage shall be written on an ISO occurrence basis form and shall include Bodily Injury, Personal Injury, Property Damage, Contractual Liability, Products and Completed Operations, Independent Contractors; Broad Form Commercial General Liability Endorsement, (XCU) Exclusions deleted and a per contract aggregate coverage. This coverage shall be primary to the Additional Insureds and not contributing with any other insurance or similar protection available to the Additional Insureds, whether said other available coverage be primary, contributing, or excess.
 - b. Workers Compensation Insurance, if not a sole proprietor, in accordance with Michigan statutory requirements, including Employers Liability coverage.

- c. Commercial Automobile Insurance in the amount of not less than \$1,000,000 combined single limit per accident with the City of Flint and including all elected and appointed officials, all employees and volunteers, all boards, commissions and/or authorities and their board members, employees, and volunteers, named as "Additional Insureds." This coverage shall be written on ISO business auto forms covering Automobile Liability, code "any auto."

Vendor shall furnish the City with two certificates of insurance for all coverage requested with original endorsements for those policies requiring the Additional Insureds. All certificates of insurance must provide the City of Flint with not less than thirty (30) days advance written notice in the event of cancellation, non-payment of premium, non-renewal, or any material change in policy coverage. In addition, the wording "Endeavor to" and "but failure to mail such notice shall impose no obligation or liability of any kind upon the Vendor, its agents or representatives" must be removed from the standard ACORD cancellation statement.

- d. These certificates must identify the City of Flint, Finance Department, as the "Certificate Holder." Vendor must provide, upon request, certified Vendor of all insurance policies. If any of the above policies are due to expire during the term of this contract, Vendor shall deliver renewal certificates and copies of the new policies to the City of Flint at least ten days prior to the expiration date. Vendor shall ensure that all subcontractors utilized obtain and maintain all insurance coverage required by this provision.

- 11. Certification, Licensing, Debarment, Suspension and Other Responsibilities:** Vendor warrants and certifies that Vendor and/or any of its principals are properly certified and licensed to perform the duties required by this Agreement in accord with laws, rules, and regulations, and is not presently debarred, suspended, proposed for debarment or declared ineligible for the award of any Federal contracts by any Federal agency. Should it be determined that Vendor performed work under this Agreement while in non-compliance with this provision, Vendor agrees to reimburse the City for any costs that the City must repay to any and all entities.
- 12. Force Majeure:** Neither party shall be responsible for damages or delays caused by Force Majeure or other events beyond the control of the other party, and which could not reasonably have been anticipated or prevented. For purposes of this Agreement, Force Majeure includes, but is not limited to, adverse weather conditions, floods, epidemics or pandemics, war, riot, strikes, lockouts, and other industrial disturbances; unknown site conditions, accidents, sabotage, fire, and acts of God. Should Force Majeure occur, the parties shall mutually agree on the terms and conditions upon which the services may continue within seven days of the discovery of the event.
- 13. Good Standing:** Vendor must remain current and not be in default of any obligations due to the City, including the payment of taxes, water & sewer costs, fines, penalties, licenses, or other monies. Violations of this clause shall constitute a substantial and material breach of this Agreement, which shall constitute good cause for the termination of this Agreement.
- 14. Indemnification:** To the fullest extent permitted by law, Vendor agrees to defend, pay on behalf of, indemnify, and hold harmless the City, its elected and appointed officials, employees and volunteers against any and all claims, demands, suits, or losses, including all costs connected therewith, and for any damages which may be asserted, claimed, or recovered against or from the City, its elected and appointed officials, employees, volunteers or others working on behalf of the City, arising out of or related to Vendor's performance of the Agreement. Should Vendor fail to indemnify the City in the above-mentioned circumstances, the City may exercise its option to deduct the cost that it incurs from any payments due under this Agreement or may file an action in a court of competent jurisdiction, the costs of which shall be paid by Vendor. This provision shall survive the termination and/or expiration of this agreement in perpetuity.

15. **Laws and Ordinances:** Vendor shall obey and abide by all of the laws, rules and regulations of the United States, State of Michigan, Genesee County and the City of Flint during the performance of this agreement. Additionally, should Vendor violate Federal and/or State criminal law involving fraud, bribery, or gratuity violations potentially affecting the Agreement, they should disclose such to the City upon notice of these violations.
16. **Modifications:** Any modifications to this Agreement must be in writing and signed by the Parties or the authorized employee, officer, board or council representative of the parties authorized to make such contractual modifications under State law and local ordinances.
17. **No Third-Party Beneficiary:** This Agreement is for the sole benefit of the parties and their respective successors, and nothing in this Agreement, express or implied, is intended to or shall confer on any other person or entity any legal or equitable right, benefit or remedy of any nature whatsoever under or by reason of this Agreement.
18. **Non-Assignability:** Vendor shall not assign or transfer any interest in this Agreement without the prior written consent of the City.
19. **Non-Disclosure/Confidentiality:** Vendor agrees that it will not disclose any such information provided to Vendor in furtherance of this Agreement, or in any other way make such documents public, without the express written approval of the City or the order of a court of competent jurisdiction.
20. **Non-Discrimination:** Vendor shall comply with the Elliott Larsen Civil Rights Act, 1976 PA 453, as amended, the Persons with Disabilities Civil Rights Act, 1976 PA 220, as amended, and all other federal, state, and local laws relating to nondiscrimination. Vendor shall not discriminate against any employee or applicant for employment with respect to his or her hire, tenure, terms, conditions, or privileges of employment, or any matter directly or indirectly related to employment, because of his or her race, religion, color, national origin, age, sex, height, weight, marital status, association with the federal government, or physical or mental disability that is unrelated to the individual's ability to perform the duties of a particular job or position or status with respect to public assistance. A breach of this covenant is a material breach of this Agreement.
21. **Anti-Lobbying:** Vendor shall not use any of the grant funds awarded in this Agreement for the purpose of lobbying as defined in the State of Michigan's lobbying statute, MCL 4.415(2) or for the purpose of litigation against the State or City.
22. **Ethics:** Pursuant to the Flint City Charter §1-602 (I), every public servant, volunteer and city contractor is to receive training and be provided with a copy of the ethical standards set forth in §1-602 of the Charter. Therefore, Vendor acknowledges receipt of Flint City Charter §1-602 and agrees that Vendor and its staff shall abide by the terms therein and participate in any training provided by the City as may be necessary from time to time.
23. **Notices:** Notices to the City of Flint shall be deemed sufficient if in writing and mailed, postage prepaid, addressed to the **(Davina Donahue and City Clerk, City of Flint, 1101 S. Saginaw Street, Flint, Michigan 48502)**, or to such other address as may be designated in writing by the City from time to time. Notices to Vendor shall be deemed sufficient if in writing and mailed, postage prepaid, addressed to: Beatrice Construction, LLC. ATTN: Aaron O'Neal goneal@beatriceconstruction.com (586) 615-5867 34637 Lawless St. Clinton Township MI 48035) or to such other address as may be designated in writing by Vendor from time to time.
24. **Records Property of City:** All documents, information, reports and the like prepared or generated by Vendor as a result of this Agreement shall become the sole property of the City and shall be disclosed to the City, or its authorized representatives, upon request.

25. **Severability:** If any terms of this Agreement or the application of them to any person or circumstance are determined to be null and void, ineffectual, invalid or unenforceable by any competent tribunal, the remaining terms or the application of the terms to persons or circumstances other than to those which were determined to be invalid or unenforceable shall not be affected and shall continue in full force and effect.
26. **Termination:** This Agreement may be terminated by either party hereto by submitting a notice of termination to the other party. The City, through its City Administrator, may terminate this agreement upon actual notice to Vendor. Vendor may terminate this agreement by providing written notice that shall be effective fourteen (14) days from the date it is submitted unless otherwise agreed to by the parties hereto. Vendor, upon receiving such notice and prorated payment upon termination of this Agreement shall give to the City all pertinent records, data, and information created up to the date of termination to which the City, under the terms of this Agreement, is entitled.
27. **Time of Performance:** Vendor's services shall commence immediately upon receipt of the notice to proceed and shall be carried out forthwith and without unreasonable delay.
28. **Union Compliance:** Vendor agrees to comply with all regulations and requirements of any national or local union(s) that may have jurisdiction over any of the materials, facilities, services, or personnel to be furnished by the City. However, this provision does not apply if its application would violate Public Act 98 of 2011.
29. **Waiver:** Failure of the City to insist upon strict compliance with any of the terms, covenants, or conditions of this Agreement shall not be deemed a waiver of any term, covenant, or condition. Any waiver or relinquishment of any right or power hereunder at any one or more times shall not be deemed a waiver or relinquishment of that right or power at any other time.
30. **Electronic Signatures:** This Agreement may be signed by the parties hereto by means of electronic signature, utilizing Adobe Acrobat or a like program with similar security features.
31. **Effective Date:** This Agreement shall be effective June 2nd, 2026.
32. **Venue:** The Parties consent to venue in Genesee County courts should any action be brought to enforce the terms of this Agreement.
33. **Whole Agreement:** This Agreement and the documents cited herein contain the entire understanding between and among the parties concerning these matters and supersedes any prior understandings and agreements between and among them respecting the subject matter of this Agreement.

[SIGNATURES ON NEXT PAGE]

Beatrice Construction, LLC:

By: _____

_____ **Date**

Its: _____

CITY OF FLINT, a Michigan Municipal Corp.:

Clyde D. Edwards City Administrator

_____ **Date**

Mayor Sheldon Neeley

_____ **Date**

APPROVED AS TO FORM:

JoAnne Gurley, City Attorney

_____ **Date**

EXHIBIT A



May 4, 2026

To whom this may concern:

Beatrice Construction LLC will only be able to bid on five of the properties due to the time constraint. Designing and submitting of drawing to home owners and the Building Department for approval along with City inspections is going to be a challenge.

Signature: _____

Garry O'Neal

Date: _____

5-4-2026



❖ EXHIBIT A - SUBMITTAL WITH DETAILED SUMMARY OF PRICING

SCOPE OF WORK ATTACHED SEPARATELY.

1. Failure to use this bid form shall result in bid disqualification.
2. Failure to bid on all items shall result in an "incomplete bid" determination.
3. List value-added considerations on a separate sheet of paper.
4. All bid pricing to include shipping and freight charges.

THIS PAGE MUST BE COMPLETED AND INCLUDED WITH THE BID

The undersigned hereby certifies, on behalf of the respondent named in this Certification (the "Respondent"), that the information provided in this offer submitted to the City of Flint, Department of Purchase and Supplies is accurate and complete, and that I am duly authorized to submit same. I hereby certify that the Respondent has reviewed all documents and requirements included in this offer and accept its terms and conditions.

Terms: Net 30

Fed. ID #: 30-0146657

Company (Respondent): Beatrice Construction LLC.

Address: 34637 Lawless St.

Clinton Township

City, State & Zip Code: MI 48035

Phone / Fax Number: (586) 948-9227 FAX: _____

Email: goneal@beatriceconstruction.com

Print Name and Title: Garry O'Neal Owner

(Authorized Representative)

Signed: 

(Authorized Representative)

EXHIBIT B - QUALIFICATIONS AND LICENSES REQUIREMENTS

Please give a synopsis of your qualifications and experience with this service:

Garry O'Neal and Aaron O'Neal are licensed builders and have provided rehab in the public and private sectors.

Please list Licenses:

**Builder License
Asbestos Awareness Certification
EPA Lead Certification
OSHA 10 Certification**

How long have you been in business?

10 Years

Have you done business with the City of Flint?

No

If yes, please state the project name.

❖ EXHIBIT D – LIST OF REFERENCES: (3) SIMILAR SCOPE OF WORK FROM THE LAST 5 YEARS

Providing the following contact information enables the City of Flint to contact those accounts as references.

Reference #1:

Company/Municipality: Detroit Land Bank Authority
Contact Person: Robert Saxon Title: Construction Manager
Address: 500 Griswold St. Suite 1200,
City: Detroit State: MI Zip: 48226
Telephone: 313-261-9978 Fax: _____
Email: rsaxon@detroitlandbank.org
Type of Project: Housing Renovation

Project Timeline (Dates): _____ Budget: _____

Reference #2:

Company/Municipality: Detroit Land Bank Authority
Contact Person: John Kostadinovski Title: Project Manager
Address: 500 Griswold St. Suite 1200,
City: Detroit State: MI Zip: 48226
Telephone: 313-989-4606 Fax: _____
Email: jkosta@detroitlandbank.org
Type of Project: Housing Renovation

Project Timeline (Dates): _____ Budget: _____

❖ EXHIBIT D – LIST OF REFERENCES: (3) SIMILAR SCOPE OF WORK FROM
THE LAST 5 YEARS (CONTINUES)

Reference #3:

Company/Municipality: New Decade - New Home

Contact Person: Walter Williams Title: HUD Rehab Consultant

Address: 19377 Fielding St.

City: Detroit State: MI Zip: 48219

Telephone: 313-399-7016 Fax: _____

Email: 203k@myrehabconsultant.com

Type of Project: Home Renovation

Project Timeline (Dates): _____ Budget: \$ 120,114.26

10/17/2025- 02/03/2026

❖ EXHIBIT G – CITY OF FLINT AFFADAVIT

FOR CORPORATION

STATE OF Michigan

S.S.

COUNTY OF Genesee

Garry O'Neal being duly sworn, deposes and says that she/he/they
is Qualifying Officer of Beatrice Construction LLC.
(Official Title) (Name of Corporation)

a corporation duly organized and doing business under the laws of the State of Michigan
the corporation making the within and foregoing bid; that they executed said bid in behalf of said corporation by
authority of its Board of Directors; that said bid is genuine and not sham or collusive and is not made in the
interests of or on behalf of any person not herein named, and that they have not and said bidder has not directly
or indirectly induced or solicited any other person or corporation to refrain from bidding, that they have not and
said bidder has not in any manner sought by collusion to secure to themselves or to said corporation an advantage
over other bidders.

Subscribed and sworn to before me at _____, in said County and State,

this 4th day of May, A.D. 2020

Annette O'Neal
*Notary Public Genesee County, Michigan

My Commission expires August 2029



R647801

GRETCHEN WHITMER
Governor

Michigan Department of Licensing and Regulatory Affairs
Bureau of Construction Codes
Company Builder License

BEATRICE CONSTRUCTION LLC
34837 LAWLESS ST
CLINTON TOWNSHIP, MI 48035

Qualifying Officer:
Garry William O'Neal
Qualifying Officer #
2101141878

MUST BE DISPLAYED IN A CONSPICUOUS PLACE

License No.
2102168064

Expiration Date:
05/31/2029

This document is duly
issued under the laws of the
State of Michigan

R651704

GRETCHEN WHITMER
Governor

Michigan Department of Licensing and Regulatory Affairs
Bureau of Construction Codes
Individual Builder License

AARON CHRISTOPHER O'NEAL SR
36463 EGAN
CLINTON TOWNSHIP, MI 48035

MUST BE DISPLAYED IN A CONSPICUOUS PLACE

License No.
2101148015

Expiration Date:
05/31/2029

This document is duly
issued under the laws of the
State of Michigan



A 360training® Company

CERTIFICATE OF COMPLETION

This certifies that

Aaron O'neal

has successfully completed the course

Asbestos Awareness Online Training



Course Duration
15



Completion Date
03/25/2026



Certificate #
000041257895

Samantha Montalbano, Chief Operating Officer

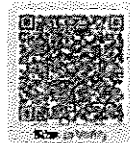

This certificate is non-transferable and expires 2 year from the date of issuance and/or completion.

6504 Bridge Point Parkway Suite 100 | Austin, TX 78730 | 360training.com



A 360training® Company

CERTIFICATE OF COMPLETION

This certifies that

Garry O'neal

has successfully completed the course

Asbestos Awareness Online Training



Course Duration
1.5



Completion Date
03/24/2026



Certificate #
000041241748

Samantha Montalbano, Chief Operating Officer

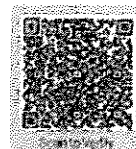

This certificate is non-transferable and expires 2 year from the date of issuance and/or completion

6504 Bridge Point Parkway, Suite 100 | Austin, TX 78730 | 360training.com

United States Environmental Protection Agency

This is to certify that

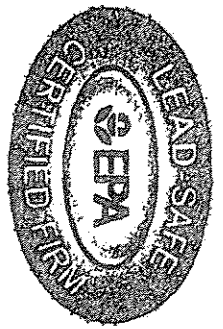

Beatrice Construction LLC

has fulfilled the requirements of the Toxic Substances Control Act (TSCA) Section 402, and has received certification to conduct lead-based paint removal, repair, and painting activities pursuant to 40 CFR Part 745.89

In the Jurisdiction of:

All EPA Administered States, Tribes, and Territories

This certification is valid from the date of issuance and expires March 12, 2027

NAT-F222683-1

Certification #

February 26, 2022

Issued On

A handwritten signature in cursive script that reads "Michelle Price".

Michelle Price, Chief

Lead, Heavy Metals, and Inorganics Branch



866-906-9190
www.utia.edu/ded/osha

OSHA recommends Outreach Training Courses as an orientation to occupational safety and health for workers. Participation is voluntary. Workers must receive additional training on specific hazards of their job. This course completion card does not expire.

Use or distribution of this card for fraudulent purposes, including false claims of having received training, may result in prosecution under 18 U.S.C. 1001. Potential penalties include substantial criminal fines, imprisonment up to 5 years, or both.



Rev. 1/2016



26-007385332

This card acknowledges that the recipient has successfully completed

10-hour Construction Safety and Health

This card issued to:

ANNETTE O'NEAL

Curtis Eugene Chambers
Trainer Name

02/06/2022
Date of Issue



CERTIFICATE OF LIABILITY INSURANCE

DATE (MM/DD/YYYY)
05/04/2026

THIS CERTIFICATE IS ISSUED AS A MATTER OF INFORMATION ONLY AND CONFERS NO RIGHTS UPON THE CERTIFICATE HOLDER. THIS CERTIFICATE DOES NOT AFFIRMATIVELY OR NEGATIVELY AMEND, EXTEND OR ALTER THE COVERAGE AFFORDED BY THE POLICIES BELOW. THIS CERTIFICATE OF INSURANCE DOES NOT CONSTITUTE A CONTRACT BETWEEN THE ISSUING INSURER(S), AUTHORIZED REPRESENTATIVE OR PRODUCER, AND THE CERTIFICATE HOLDER.

IMPORTANT: If the certificate holder is an ADDITIONAL INSURED, the policy(ies) must have ADDITIONAL INSURED provisions or be endorsed. If SUBROGATION IS WAIVED, subject to the terms and conditions of the policy, certain policies may require an endorsement. A statement on this certificate does not confer rights to the certificate holder in lieu of such endorsement(s).



PRODUCER Next First Insurance Agency, Inc. PO Box 60787 Palo Alto, CA 94306		CONTACT NAME: PHONE (A/C, H/A, Ext): (855) 222-5919 FAX (A/C, No): E-MAIL: support@nextinsurance.com ADDRESS:	
INSURED Beatrice Construction LLC. 34637 Lawless St Clinton Township, MI 48035		INSURER(S) AFFORDING COVERAGE INSURER A: Next Insurance US Company NAIC # 16285 INSURER B: INSURER C: INSURER D: INSURER E: INSURER F:	

COVERAGES **CERTIFICATE NUMBER: 382349343** **REVISION NUMBER:**

THIS IS TO CERTIFY THAT THE POLICIES OF INSURANCE LISTED BELOW HAVE BEEN ISSUED TO THE INSURED NAMED ABOVE FOR THE POLICY PERIOD INDICATED. NOTWITHSTANDING ANY REQUIREMENT, TERM OR CONDITION OF ANY CONTRACT OR OTHER DOCUMENT WITH RESPECT TO WHICH THIS CERTIFICATE MAY BE ISSUED OR MAY PERTAIN, THE INSURANCE AFFORDED BY THE POLICIES DESCRIBED HEREIN IS SUBJECT TO ALL THE TERMS EXCLUSIONS AND CONDITIONS OF SUCH POLICIES. LIMITS SHOWN MAY HAVE BEEN REDUCED BY PAID CLAIMS.

INSR LTR	TYPE OF INSURANCE	ADDITIONAL INSURED (Y/N)	POLICY NUMBER	POLICY EFF (MM/DD/YYYY)	POLICY EXP (MM/DD/YYYY)	LIMITS
A	<input checked="" type="checkbox"/> COMMERCIAL GENERAL LIABILITY <input type="checkbox"/> CLAIMS-MADE <input checked="" type="checkbox"/> OCCUR GEN'L AGGREGATE LIMIT APPLIES PER: <input checked="" type="checkbox"/> POLICY <input type="checkbox"/> PROJECT <input type="checkbox"/> LOC OTHER:	X	NXT7FDRF9C-01-GL	10/30/2025	10/30/2026	EACH OCCURRENCE \$1,000,000.00 DAMAGE TO RENTED PREMISES (Ea occurrence) \$100,000.00 MED EXP (Any one person) \$10,000.00 PERSONAL & ADV INJURY \$1,000,000.00 GENERAL AGGREGATE \$1,000,000.00 PRODUCTS - COMPIOP AGG \$1,000,000.00 \$
	AUTOMOBILE LIABILITY <input type="checkbox"/> ANY AUTO <input type="checkbox"/> OWNED AUTOS ONLY <input type="checkbox"/> SCHEDULED AUTOS <input type="checkbox"/> HIRED AUTOS ONLY <input type="checkbox"/> NON-OWNED AUTOS ONLY					COMBINED SINGLE LIMIT (Ea accident) \$ BODILY INJURY (Per person) \$ BODILY INJURY (Per accident) \$ PROPERTY DAMAGE (Per accident) \$ \$
A	<input checked="" type="checkbox"/> UMBRELLA LIAB <input checked="" type="checkbox"/> OCCUR <input type="checkbox"/> EXCESS LIAB <input type="checkbox"/> CLAIMS-MADE <input type="checkbox"/> DED <input type="checkbox"/> RETENTION \$	X	NXT7FDRF9C-01-GL	10/30/2025	10/30/2026	EACH OCCURRENCE \$ 2,000,000.00 AGGREGATE \$ 2,000,000.00 \$
	WORKERS COMPENSATION AND EMPLOYERS' LIABILITY ANY PROPRIETOR/PARTNER/EXECUTIVE OFFICER/MEMBER EXCLUDED? (Mandatory in NH) If yes, describe under DESCRIPTION OF OPERATIONS below	Y/N	N/A			PER STATUTE <input type="checkbox"/> OTH-ER <input type="checkbox"/> E.L. EACH ACCIDENT \$ E.L. DISEASE - EA EMPLOYEE \$ E.L. DISEASE - POLICY LIMIT \$
A	Contractors Errors and Omissions	X	NXT7FDRF9C-01-GL	10/30/2025	10/30/2026	Each Occurrence: \$10,000.00 Aggregate: \$20,000.00

DESCRIPTION OF OPERATIONS / LOCATIONS / VEHICLES (ACORD 101, Additional Remarks Schedule, may be attached if more space is required)
The Certificate Holder is City of Flint. This Certificate Holder is an Additional Insured on the General Liability policy and Umbrella/Excess Liability policy per the Additional Insured Automatic Status Endorsement. All Additional Insured privileges apply only if required by written agreement between the Certificate Holder and the insured, and are subject to policy terms and conditions.

CERTIFICATE HOLDER City of Flint 1101 S Saginaw Street Flint, MI 48502	LIVE CERTIFICATE  Click or scan to view	CANCELLATION SHOULD ANY OF THE ABOVE DESCRIBED POLICIES BE CANCELLED BEFORE THE EXPIRATION DATE THEREOF, NOTICE WILL BE DELIVERED IN ACCORDANCE WITH THE POLICY PROVISIONS. AUTHORIZED REPRESENTATIVE 
--	---	---

QUESTIONS

Is your company able to comply with the deadline of August 28th?

How many employees do you have that will be responsible for the work?

Please provide a timeline for completion of the work, keeping in mind the Bid will be closed May 4th, and all construction must be finished by August 28th?

BID SHEET

PROPERTY #1	\$ _____
PROPERTY #2	\$ _____
PROPERTY #3	\$ _____
PROPERTY #4	\$ _____
PROPERTY #5	\$ <u>18,095.00</u>
PROPERTY #6	\$ <u>12,950.00</u>
PROPERTY #7	\$ _____
PROPERTY #8	\$ _____
PROPERTY #9	\$ _____
PROPERTY #10	\$ _____
PROPERTY #11	\$ _____
PROPERTY #12	\$ <u>20,069.00</u>
PROPERTY #13	\$ <u>11,340.00</u>
PROPERTY #14	\$ _____
PROPERTY #15	\$ _____
PROPERTY #16	\$ _____
PROPERTY #17	\$ _____
PROPERTY #18	\$ <u>35,640.00</u>
PROPERTY #19	\$ _____

GRAND TOTAL \$98,094.00



Specs By Location

3/3/2026

Address: REDACTED 5		Unit: Unit 01			
Location: 1 - Exterior		Approx. Wall SF: 0	Ceiling/Floor SF: 0		
Spec #	Spec	Quantity	Units	Unit Price	Total Price
Trade: 1 General Requirements					
1	Custom ANTISLIP TAPE -- REMOVE & REPLACE Remove existing antislip tape from ramp, porch, and steps. Replace with new 36" antislip tape.	35.00	LF	\$28.00	\$980.00
Trade: 6 Concrete & Paving					
2	980 DRIVEWAY--CONCRETE At North side of existing driveway, level surface, prepare a 3" gravel base over a uniformly graded & compacted subgrade. Form and pour 3000 psi air entrained concrete, 4" thick by 10' wide driveway. Provide #10 welded wire mesh, expansion joints at 10' intervals, and a broom finish surface that directs water away from the building. Remove forms. Regrade and seed disturbed areas. **Homeowner is required to combine lots in order to proceed with this modification**	600.00	SF	\$25.00	\$15,000.00
Trade: 10 Carpentry					
3	2685 AWNING--ALUMINUM Remove gutter from fascia above front entrance. Fabricate and install an enameled aluminum awning securely attached with aluminum screws through fascia to framing and to top rail of porch.	36.00	SF	\$37.50	\$1,350.00
4	3522 WOOD STAIR HANDRAIL--REPLACE EXT Remove existing handrail and braces. Install preservative treated, code approved grabbable handrail supported by braces along all interior sides of ramp, porch, and steps.	68.00	LF	\$11.25	\$765.00
Location Total:				
Unit Total for REDACTED 5:				
Address Grand Total for REDACTED 5:					\$18,095.00

Bidder: Beatrice Construction LL



Specs By Location

3/3/2026

Address: REDACTED 6

Unit: Unit 01

Location: 1 - General Requirements

Approx. Wall SF: 0

Ceiling/Floor SF: 0

Spec #	Spec	Quantity	Units	Unit Price	Total Price
--------	------	----------	-------	------------	-------------

Trade: 1 General Requirements

1	36	BUILDING PERMIT REQUIRED The contractor is responsible for submitting this owner-prepared work write up to the building department, applying for, paying for and receiving a building permit prior to starting any work. Contractor will also be responsible for coordinating a final inspection by the local building department.	1.00	EA		\$1,600.00
---	----	--	------	----	--	------------

Trade: 5 Demolition & Disposal

2	800	DUMPSTER--20 CUBIC YARDS After procuring all required permits, place a 20 cubic yard, roll-off dumpster or equivalent disposal method without damaging the site. Collect construction debris using dust control methods.	1.00	EA		\$750.00
---	-----	--	------	----	--	----------

Location Total: _____

Location: 2 - Exterior (Front)

Approx. Wall SF: 0

Ceiling/Floor SF: 0

Spec #	Spec	Quantity	Units	Unit Price	Total Price
--------	------	----------	-------	------------	-------------

Trade: 5 Demolition & Disposal

3	755	DEMO/REBUILD PORCH Demolish entire porch including deck, railing/walls, substructure, and steps and dispose of in code legal dump. Rake yard clean. Replace existing footprint and design with treated lumber to code. Include railing on both sides. Patch trim and siding matching as closely as possible in like kind.	50.00	SF	\$92.00	\$4,600.00
---	-----	---	-------	----	---------	------------

Trade: 10 Carpentry

4	3580	LOW-RISE STAIR SYSTEM Construct a low-rise treated stair system with handrail on both sides. Stairs to have a 11' minimum run, and 7" maximum rise.	1.00	EA		\$3,000.00
---	------	---	------	----	--	------------

Location Total: _____

Location: 3 - Exterior (Rear)

Approx. Wall SF: 0

Ceiling/Floor SF: 0

Spec #	Spec	Quantity	Units	Unit Price	Total Price
--------	------	----------	-------	------------	-------------

Address: REDACTED 6 **Unit: Unit 01**

Location: 3 - Exterior (Rear) **Approx. Wall SF: 0** **Ceiling/Floor SF: 0**

	Spec #	Spec	Quantity	Units	Unit Price	Total Price
--	--------	------	----------	-------	------------	-------------

Trade: 10		Carpentry				
------------------	--	------------------	--	--	--	--

5	3580	LOW-RISE STAIR SYSTEM Remove steps at rear entry. Replace with low rise treated stair system with handrail on both sides. Stairs to have a 11" minimum run, and 7" maximum rise.	1.00	EA		\$3,000.00
---	------	--	------	----	--	------------

Location Total: _____

Unit Total for REDACTED 6 : _____

Address Grand Total for REDACTED 6: \$12,950.00

Bidder: Beatrice Construction LLC



Specs By Location

4/2/2026

Address: REDACTED 12

Unit: Unit 01

Location: 1 - General Requirements

Approx. Wall SF: 0

Ceiling/Floor SF: 0

Spec #	Spec	Quantity	Units	Unit Price	Total Price
--------	------	----------	-------	------------	-------------

Trade: 1 General Requirements

1	38	PLUMBING PERMIT REQUIRED Prior to the start of work, the contractor shall, if necessary, create a riser diagram, septic layout and all other documentation needed to apply for, pay for and receive a plumbing permit on behalf of the owner.	1.00	EA	_____	\$1,600.00
---	----	---	------	----	-------	------------

Trade: 5 Demolition & Disposal

2	800	DUMPSTER--20 CUBIC YARDS After procuring all required permits, place a 20 cubic yard, roll-off dumpster or equivalent disposal method without damaging the site. Collect construction debris using dust control methods.	1.00	EA	_____	\$750.00
---	-----	--	------	----	-------	----------

Trade: 6 Concrete & Paving

3	850	CONCRETE--GENERAL REQS. All concrete shall be 3% air entrained, ready mix, 2500 psi, max.4" slump, unless otherwise specified. Place all concrete on original soil or wet fill compacted to 90% against straight, solid, forms between temps.of 40-100 F. All concrete shall be: free of voids and cavities; treated with a liquid curing compound and protected from the weather while curing.	1.00	EA	_____	_____
---	-----	---	------	----	-------	-------

Location Total: _____

Location: 2 - Exterior

Approx. Wall SF: 0

Ceiling/Floor SF: 0

Spec #	Spec	Quantity	Units	Unit Price	Total Price
--------	------	----------	-------	------------	-------------

Trade: 6 Concrete & Paving

4	855	DEMO CONCRETE Break up concrete walkway from driveway to front steps and remove off site to code legal dump.	70.00	SF	\$21.00	\$1,470.00
5	1065	CONCRETE FORMWORK--CUSTOM Form and pour new concrete walkway from front steps to driveway. Ensure proper substrate and compaction based on requirements listed in the "General Requirements" Section of this spec sheet and according to all local building code requirements and manufacturer specifications. Broom finish.	100.00	SF	\$22.50	\$2,250.00

Address: REDACTED 12 **Unit: Unit 01**

Location: 2 - Exterior Approx. Wall SF: 0 Ceiling/Floor SF: 0

Spec #	Spec	Quantity	Units	Unit Price	Total Price
--------	------	----------	-------	------------	-------------

Trade: 10 **Carpentry**

6	3530 GUARD RAIL--WROUGHT IRON Install a black, wrought iron railing of bar stock wrought steel with solid twist balusters. Bolt securely in wall and floor with lead shielded lag bolts. Embed in concrete in ground when servicing steps. Touch up paint.	16.00	LF	\$125.00	\$2,000.00
---	--	-------	----	----------	------------

7	3580 LOW-RISE STAIR SYSTEM - CONCRETE Remove steps and handrail at front entry. Replace with low rise concrete stair system to have a 11" minimum run, and 7" maximum rise. Expand stair footprint to match width of porch. **See rear entrance for template**	1.00	EA		\$1,500.00
---	--	------	----	--	------------

Location Total: _____

Location: 3 - North Bathroom Approx. Wall SF: 0 Ceiling/Floor SF: 0

Spec #	Spec	Quantity	Units	Unit Price	Total Price
--------	------	----------	-------	------------	-------------

Trade: 10 **Carpentry**

8	5909 VINYL PLANK FLOORING -- INSTALL Remove existing flooring. Install new vinyl plank flooring in owner's choice of color from in-stock options. New vinyl plank floor will be 100% waterproof- Home Depot Home Decorators style vinyl plank flooring or approved equal 4.2 mm thickness or greater. Include all transition pieces at hallways, base trim, and stair nosing covers.	24.00	SF	\$21.00	\$504.00
---	--	-------	----	---------	----------

Trade: 22 **Plumbing**

9	7011 COMMODE--ACCESSIBLE Install a 2 piece, close coupled, white, vitreous china, comfort height commode with a maximum water usage per flush of 1.6 Gallons. Include plastic or pressed wood white seat, supply pipe, shut-off valve, flap valve and wax seal. Use 14" rough-in when replacing wall hung commode, and 12" rough-in to replace close coupled commode. Commode shall measure at least 19" from floor to top of seat.	1.00	EA		\$1,200.00
---	---	------	----	--	------------

Location Total: _____

Location: 4 - South Bathroom Approx. Wall SF: 0 Ceiling/Floor SF: 0

Spec #	Spec	Quantity	Units	Unit Price	Total Price
--------	------	----------	-------	------------	-------------

Trade: 10 **Carpentry**

10	5909 VINYL PLANK FLOORING -- INSTALL Install new vinyl plank flooring over existing flooring in owner's choice of color from in-stock options. New vinyl plank floor will be 100% waterproof- Home Depot Home Decorators style vinyl plank flooring or approved equal 4.2 mm thickness or greater. Include all transition pieces at hallways, base trim, and stair	35.00	SF	\$17.00	\$595.00
----	--	-------	----	---------	----------

Address: REDACTED 12 Unit: Unit 01

Location: 4 - South Bathroom Approx. Wall SF: 0 Ceiling/Floor SF: 0

Spec # Spec Quantity Units Unit Price Total Price

Trade: 10 Carpentry
nosing covers.

Trade: 22 Plumbing

11 7011 **COMMUNE-ACCESSIBLE** 1.00 EA _____ \$1,200.00

Install a 2 piece, close coupled, white, vitreous china, comfort height commode with a maximum water usage per flush of 1.6 Gallons. Include plastic or pressed wood white seat, supply pipe, shut-off valve, flap valve and wax seal. Use 14" rough-in when replacing wall hung commode, and 12" rough-in to replace close coupled commode. Commode shall measure at least 19" from floor to top of seat.

12 7290 **SHOWER-ACCESSIBLE** 1.00 EA _____ \$7,000.00

Remove existing tub and tile surround. Install a STERLING Accord Shower Stall or equal to fit existing opening. Floor shall be non-slip with a maximum 4" lip at entrance. Include hinged seat 19" off floor or provide removable seat, depending on availability on selected model. Include 2 1-1/2" outside diameter grab bars*. A single lever control valve shall feed a fixed shower head and a hand held shower with 5' of stainless steel wrapped hose, through a single lever diversion valve. Repair all tearout.

*It is the contractor's responsibility to coordinate with homeowner on grab bar positioning. Determine positioning prior to purchasing shower unit to ensure if a grab bar within the shower is necessary and if available models accommodate that positioning.

Location Total: _____

Unit Total for REDACTED 12: _____

Address Grand Total for REDACTED 12: \$20,069.00

Bidder: Beatrice Construction LLC



Specs By Location

4/7/2026

Address: REDACTED 13

Unit: Unit 01

Location: 1 - General Requirements

Approx. Wall SF: 0

Ceiling/Floor SF: 0

Spec #	Spec	Quantity	Units	Unit Price	Total Price
--------	------	----------	-------	------------	-------------

Trade: 1 General Requirements

1	38	PLUMBING PERMIT REQUIRED Prior to the start of work, the contractor shall, if necessary: create a riser diagram, septic layout and all other documentation needed to apply for, pay for and receive a plumbing permit on behalf of the owner.	1.00	EA		\$1,600.00
---	----	---	------	----	--	------------

Trade: 6 Concrete & Paving

2	850	CONCRETE--GENERAL REQS. All concrete shall be 3% air entrained, ready mix, 2500 psi, max.4" slump, unless otherwise specified. Place all concrete on original soil or wet fill compacted to 90% against straight, solid, forms between temps.of 40-100 F. All concrete shall be: free of voids and cavities; treated with a liquid curing compound and protected from the weather while curing.	1.00	EA		
---	-----	---	------	----	--	--

Location Total: _____

Location: 2 - Exterior

Approx. Wall SF: 0

Ceiling/Floor SF: 0

Spec #	Spec	Quantity	Units	Unit Price	Total Price
--------	------	----------	-------	------------	-------------

Trade: 5 Demolition & Disposal

3	765	DEMO CONCRETE Remove tavers at front porch and save them for homeowner. Break up concrete pad in front of porch and remove off site to code legal dump.	15.00	SF	\$21.00	\$315.00
---	-----	---	-------	----	---------	----------

Trade: 6 Concrete & Paving

4	1065	CONCRETE FORMWORK--CUSTOM Form and pour new pad and step at front entry to porch. Step rise should be no more than 7" and tread no less 1". Ensure proper substrate and compaction based on requirements listed in the "General Requirements" Section of this spec sheet and according to all local building code requirements and manufacturer specifications. Broom finish.	15.00	EA	\$45.00	\$675.00
---	------	---	-------	----	---------	----------

Trade: 10 Carpentry

5	3530	GUARD RAIL--WROUGHT IRON On both sides of front porch, going down steps, install a black,	14.00	LF	\$125.00	\$1,750.00
---	------	---	-------	----	----------	------------

Address: REDACTED 13 Unit: Unit 01

Location: 2 - Exterior Approx. Wall SF: 0 Ceiling/Floor SF: 0
Spec # Spec Quantity Units Unit Price Total Price

Trade: 10 Carpentry

wrought iron railing of bar stock wrought steel with solid twist balusters. Bolt securely in wall and floor with lead shielded lag bolts. Embed in concrete in ground when servicing steps. Touch up paint.

Location Total: _____

Location: 3 - Bathroom Approx. Wall SF: 0 Ceiling/Floor SF: 0
Spec # Spec Quantity Units Unit Price Total Price

Trade: 22 Plumbing

6 7290 SHOWER--ACCESSIBLE 1.00 EA _____ \$7,000.00

Remove existing tub and surround. Install a STERLING Accord Shower Stall or equal to fit existing opening. Floor shall be non-slip with a maximum 4" lip at entrance. Include hinged seat 19" off floor or provide removable seat, depending on availability on selected model. Include 2 1-1/2" outside diameter grab bars*, A single lever control valve shall feed a fixed shower head and a hand held shower with 5' of stainless steel wrapped hose, through a single lever diversion valve.

*It is the contractor's responsibility to coordinate with homeowner on grab bar positioning. Determine positioning prior to purchasing shower unit to ensure if a grab bar within the shower is necessary and if available models accommodate that positioning.

Location Total: _____

Unit Total for REDACTED 13: _____

Address Grand Total for REDACTE 13 \$11,340.00

Bidder: Beatrice Construction LLC



Specs By Location

4/14/2026

Address: REDACTED 18

Unit: Unit 01

Location: 1 - General Requirements

Approx. Wall SF: 0

Ceiling/Floor SF: 0

Spec #	Spec	Quantity	Units	Unit Price	Total Price
--------	------	----------	-------	------------	-------------

Trade: 1 General Requirements

1	38 BUILDING PERMIT REQUIRED	1.00	EA	_____	\$1600.00
---	------------------------------------	------	----	-------	-----------

The contractor is responsible for submitting this owner-prepared work write up to the building department, applying for, paying for and receiving a building permit prior to starting any work. Contractor will also be responsible for coordinating a final inspection by the local building department.

2	38 PLUMBING PERMIT REQUIRED	1.00	EA	_____	\$700.00
---	------------------------------------	------	----	-------	----------

Prior to the start of work, the contractor shall, if necessary: create a riser diagram, septic layout and all other documentation needed to apply for, pay for and receive a plumbing permit on behalf of the owner.

Trade: 5 Demolition & Disposal

3	800 DUMPSTER--20 CUBIC YARDS	1.00	EA	_____	\$750.00
---	-------------------------------------	------	----	-------	----------

After procuring all required permits, place a 20 cubic yard, roll-off dumpster or equivalent disposal method without damaging the site. Collect construction debris using dust control methods.

Trade: 6 Concrete & Paving

4	850 CONCRETE--GENERAL REQS.	1.00	EA	_____	_____
---	------------------------------------	------	----	-------	-------

All concrete shall be 3% air entrained, ready mix, 2500 psi, max.4" slump, unless otherwise specified. Place all concrete on original soil or wet fill compacted to 90% against straight, solid, forms between temps.of 40-100 F. All concrete shall be: free of voids and cavities; treated with a liquid curing compound and protected from the weather while curing.

Location Total: _____

Location: 2 - Exterior

Approx. Wall SF: 0

Ceiling/Floor SF: 0

Spec #	Spec	Quantity	Units	Unit Price	Total Price
--------	------	----------	-------	------------	-------------

Trade: 5 Demolition & Disposal

5	765 DEMO CONCRETE	840.00	SF	\$7 00	\$5,880.00
---	--------------------------	--------	----	--------	------------

Break up driveway and 40SF of walkway concrete beyond backyard gate and remove off site to code legal dump.

Address: REDACTED 18		Unit: Unit 01			
Location: 2 - Exterior		Approx. Wall SF: 0		Ceiling/Floor SF: 0	
Spec #	Spec	Quantity	Units	Unit Price	Total Price
Trade: 6 Concrete & Paving					
6	980 DRIVEWAY--CONCRETE Level surface, prepare a 3" gravel base over a uniformly graded & compacted subgrade. Form and pour 3000 psi air entrained concrete, 4" thick by 10' wide driveway. Provide #10 welded wire mesh, expansion joints at 10' intervals, and a broom finish surface that directs water away from the building. Remove forms. Regrade and seed disturbed areas.	800.00	SF	\$12.50	\$10,000.00
7	1065 CONCRETE FORMWORK--CUSTOM Form and pour concrete landing and walkway for wheelchair ramp using the requirements specified in "General Requirements" at the top of the spec sheet.	40.00	SF	\$12.50	\$500.00
Trade: 10 Carpentry					
8	3975 WHEELCHAIR RAMP At rear of house, design and construct a preservative treated wood wheelchair ramp complete with 2"x4" safety handrails and non-slip 3/4" plywood surface treatment supported by 4"x4" post set 36" in ground, in conformance with ANSI recommendations. Slope shall not exceed 1'0" rise to 12'0" run. Minimum inside width, 36". Submit preliminary drawing to owner for approval. **Design Proposal** Remove railing from NW side of back deck, build 4x8 platform and begin slope Easterly to a second landing, then slope Southerly to walkway.	184.00	SF	\$45.00	\$8,280.00
9	Custom CONSTRUCT TRANSITION RAMP Construct a small transition ramp at rear entry threshold to transition from inside the home to the back deck.	9.00	SF	\$45.00	\$405.00
Location Total:					_____
Location: 3 - Bathroom		Approx. Wall SF: 0		Ceiling/Floor SF: 0	
Spec #	Spec	Quantity	Units	Unit Price	Total Price
Trade: 10 Carpentry					
10	5909 VINYL PLANK FLOORING -- INSTALL Remove existing flooring. Install new vinyl plank flooring in owner's choice of color from in-stock options. New vinyl plank floor will be 100% waterproof- Home Depot Home Decorators style vinyl plank flooring or approved equal 4.2 mm thickness or greater. Include all transition pieces at hallways, base trim, and stair nosing covers. **It is homeowners' responsibility to move furniture and obstacles to allow for contractor installation. Contractor must coordinate this installation with homeowner**	25.00	SF	\$21.00	\$525.00
Trade: 22 Plumbing					

Address: REDACTED 18 Unit: Unit 01

Location: 3 - Bathroom Approx. Wall SF: 0 Ceiling/Floor SF: 0

Spec # Spec Quantity Units Unit Price Total Price

Trade: 22 Plumbing

11 7290 SHOWER--ACCESSIBLE 1.00 EA \$7,000.00

Remove existing tub and surround. Install a STERLING Accord Shower Stall or equal to fit existing opening. Floor shall be non-slip with a maximum 4" lip at entrance. Include hinged seat 19" off floor or provide removable seat, depending on availability on selected model. Include 2 1-1/2" outside diameter grab bars*, A single lever control valve shall feed a fixed shower head and a hand held shower with 5' of stainless steel wrapped hose, through a single lever diversion valve.

*It is the contractor's responsibility to coordinate with homeowner on grab bar positioning. Determine positioning prior to purchasing shower unit to ensure if a grab bar within the shower is necessary and if available models accommodate that positioning.

Location Total: _____

Unit Total for REDACTED 18: _____

Address Grand Total for REDACTED18: \$35,640.00

Bidder Beatrice Construction LLC



BEATRICE CONSTRUCTION LLC

Unique Entity ID JZR8CPK91RT3	CAGE / NCAGE 9D9V0	Purpose of Registration All Awards
Registration Status Active Registration	Expiration Date Jul 30, 2026	
Physical Address 34637 Lawless ST Clinton Township, Michigan 48035-3616 United States	Mailing Address 34637 Lawless ST Clinton Township, Michigan 48035-3616 United States	

Business Information

Doing Business as (blank)	Division Name (blank)	Division Number (blank)
Congressional District Michigan 10	State / Country of Incorporation Michigan / United States	URL Beatriceconstruction.com

Registration Dates

Activation Date Aug 1, 2025	Submission Date Jul 30, 2025	Initial Registration Date Sep 15, 2022
---------------------------------------	--	--

Entity Dates

Entity Start Date Jan 30, 2003	Fiscal Year End Close Date Dec 31
--	---

Immediate Owner

CAGE (blank)	Legal Business Name (blank)
------------------------	---------------------------------------

Highest Level Owner

CAGE (blank)	Legal Business Name (blank)
------------------------	---------------------------------------

Executive Compensation

Registrants in the System for Award Management (SAM) respond to the Executive Compensation questions in accordance with Section 6202 of P.L. 110-252, amending the Federal Funding Accountability and Transparency Act (P.L. 109-282). This information is not displayed in SAM. It is sent to USAspending.gov for display in association with an eligible award. Maintaining an active registration in SAM demonstrates the registrant responded to the questions.

Proceedings Questions

Registrants in the System for Award Management (SAM.gov) respond to proceedings questions in accordance with FAR 52.209-7, FAR 52.209-9, or 2. C.F.R. 200 Appendix XII. Their responses are displayed in the responsibility/qualification section of SAM.gov. Maintaining an active registration in SAM.gov demonstrates the registrant responded to the proceedings questions.

Exclusion Summary

Active Exclusions Records?

N

SAM Search Authorization

I authorize my entity's non-sensitive information to be displayed in SAM public search results:

Yes

Business Types

Entity Structure International Organization	Entity Type Business or Organization	Organization Factors Limited Liability Company
Profit Structure For Profit Organization		

Socio-Economic Types

Minority-Owned Business
Self Certified Small Disadvantaged Business
Black American Owned

Check the registrant's Reqs & Certs, if present, under FAR 52.212-3 or FAR 52.219-1 to determine if the entity is an SBA-certified HUBZone small business concern. Additional small business information may be found in the SBA's Dynamic Small Business Search if the entity completed the SBA supplemental pages during registration.

Financial Information

Accepts Credit Card Payments
No

Debt Subject To Offset
No

EFT Indicator
0000

CAGE Code
9D9V0

Points of Contact

Electronic Business

☒
Garry W O'Neal

34637 Lawless
Clinton Township, Michigan 48035
United States

Government Business

☒
Garry W O'Neal

34637 Lawless
Clinton Township, Michigan 48035
United States

Service Classifications

NAICS Codes

Primary
Yes

NAICS Codes
238115

236116

NAICS Title
New Single-Family Housing Construction (Except For-Sale Builders)

New Multifamily Housing Construction (Except For-Sale Builders)

Disaster Response

This entity does not appear in the disaster response registry.



Division of Community & Economic Development

Sheldon Neeley Mayor

Good Standing Certification

Applicant and/or Business Clearance

All applicants for City of Flint funded programs, including federal programs, must remain current and not in default on any obligations related to taxes, fines, penalties, water service, licenses or other forms of penalties.

APPLICANT NAME: Beatrice Construction LLC

HOME ADDRESS:

DBA:

BUSINESS ADDRESS: 34637 Lawless St. Clinton Township MI 48035

Please include addresses of all properties in the name of other current and/or former businesses, parent company, subsidiaries and/or divisions. Also, please include all former names used while conducting business with the City.

This section to be completed by the Department of Finance - Customer Service Div.

Please check the following divisions for the status of current and delinquent obligations owed to the City of Flint. Please circle the appropriate response for each division.

Table with 3 columns: Division (Water Div., Property Taxes Div., Income Tax Div., Enforcement, MR), Status (CURRENT, DELINQUENT), and Handwritten Notes (No water acct located, No Prop tax located, No city tax record, No MR located).

This section to be completed by the Department of Community and Economic Development

Table with 4 columns: DCED/EDC, CURRENT, DELINQUENT, N/A. Subtext: (108 Loans, EDC loans, mortgage repayments, etc.)

City of Flint DCED Representative and Date

If delinquencies exist, please indicate the date, type and amount of obligation:

Four horizontal lines for indicating delinquencies.

Shelby Bader 2/6/2026 DCED Staff Person and Date

Handwritten signature and date: 5/8-2026, City of Flint Customer Serv. Representative and Date



27720561



STATE OF MICHIGAN
CSCL/CD- 2700 - DOMESTIC LIMITED LIABILITY
COMPANY ANNUAL STATEMENT

Corporations Division Administrator

FILED

Doc #: 27720561
Filed Date: 12/16/2025

C0511-4166 12/16/2025 Received by Michigan Corporations Division

DEPARTMENT OF LICENSING AND REGULATORY AFFAIRS LIMITED LIABILITY COMPANY ANNUAL STATEMENT

Required by Section 207, Act 23, Public Act of 1993

Limited Liability Company Information

The present name of the limited liability company is: BEATRICE CONSTRUCTION, LLC
The identification number assigned by the Bureau is: 801224435
Filing Year 2026

The name of the resident agent at the registered office is:
GARRY O'NEAL

Address

34637 LAWLESS ST, CLINTON TOWNSHIP, MI 48035

Mailing Address

34637 LAWLESS, CLINTON TOWNSHIP., MI 48035

Attestations

- I understand that the information I enter into the online system is public information and will appear online and on copy requests exactly as I enter it into the system.
- I have been authorized by the business entity to file this document online.
- I, HEREBY SWEAR AND/OR AFFIRM, under penalty of law, including criminal prosecution, that the facts contained in this document are true. I certify that I am signing this document as the person(s) whose signature is required, or as an agent of the person(s) whose signature is required, who has authorized me to place his/her signature on this document.

Signature

Self

Garry O'Neal

12/16/2025

Signer's Capacity

Sign Here

Date

BEATRICE CONSTRUCTION, LLC X

<i>Entity Name</i>	BEATRICE CONSTRUCTION, LLC
<i>Identification #</i>	801224435
<i>Jurisdiction</i>	Michigan
<i>Entity Type</i>	Domestic Limited Liability Company
<i>Entity Status</i>	Active
<i>AR Standing</i>	Good
<i>AR Due Date</i>	02/15/2027
<i>Initial Filing Date</i>	01/17/2003
<i>Resident Agent Name</i>	GARRY O'NEAL
<i>Registered Office Street Address</i>	34637 LAWLESS ST, CLINTON TOWNSHIP, MI 48035
<i>Registered Office Mailing Address</i>	34637 LAWLESS, CLINTON TOWNSHIP,, MI 48035
<i>Management Type</i>	Member



**View History &
Filings**

260216



RESOLUTION NO.: _____

PRESENTED: 6-17-2026

ADOPTED: _____

A0645

BY THE CITY ADMINISTRATOR:

RESOLUTION AUTHORIZING THE ANNUAL 36-MONTH RENEWAL SUBSCRIPTION SERVICE FOR SAMSARA INC. FOR FY27

WHEREAS, the City of Flint Finance Department, Fleet Division, is requesting approval to renew the Samsara, Inc. subscription GPS service to support tracking of city-owned vehicles; and

WHEREAS, the contract term is for 36 months and supports the Fleet Division's management of City of Flint vehicles and equipment; and

WHEREAS, the City of Flint Fleet Division is requesting approval of \$92,754.00 to continue this necessary service for FY 27; and

WHEREAS, funding will come from the following account:

Account Number	Account Name/ Grant Code	Amount
661-229.000-814.600	Computer Software	\$92,754.00
	FY2026 TOTAL	\$92,754.00

THEREFORE, IT IS RESOLVED that the Flint City Council authorizes the proper city officials to purchase the annual subscription for Samsara Inc, GPS tracking system used for the management of the city's fleet vehicles in an amount Not-To-Exceed \$92,754.00 for FY27 (07/01/26 to 06/30/27).

APPROVED AS TO FORM:



JoAnne Gurley (Jun 2, 2026 15:04:46 EDT)
JoAnne Gurley, City Attorney

APPROVED AS TO FINANCE:



Phillip Moore (May 27, 2026 13:33:44 EDT)
Phillip Moore, Chief Financial Officer

FOR THE CITY OF FLINT:



Clyde Edwards (Jun 2, 2026 15:15:17 EDT)
Clyde Edwards, City Administrator

APPROVED BY CITY COUNCIL:

APPROVED AS TO PURCHASING:



Lauren Rowley, Purchasing Manager



STAFF REVIEW FORM

Effective: April 1, 2026

(Do not alter or modify this form without written permission from the City Administrator)

TODAY'S DATE: 4/24
 BID PROPOSAL #: N/A
 AGENDA ITEM TITLE: Samsara Annual Renewal fee 36month Contract Term
 PREPARED BY: Marquita Blair
 VENDOR NAME: Samsara Inc

Section 1. BACKGROUND/SUMMARY OF PROPOSED ACTION..

Vendor Compliance (This vendor has been properly vetted and the responses are below) :

Federal gov't	(All documentation current, no violations)	<input checked="" type="checkbox"/> YES	<input type="checkbox"/> NO
State gov't	(All documentation current, no violations)	<input checked="" type="checkbox"/> YES	<input type="checkbox"/> NO
City of Flint	(All documentation current, no violations)	<input checked="" type="checkbox"/> YES	<input type="checkbox"/> NO

The requesting authority is validating that this vendor has been in full compliance with all past contract provisions and has not violated the terms of any contract with the City of Flint.

NOTE: Preparer **MUST** include a response to the conditions below:

- Did we do an assessment of first consideration to internal City of Flint staff and resources (explain)?
- Why was this vendor chosen?
- What history does this vendor have with the City of Flint?
- What steps will be taken to do a post-performance of the vendor?

Samsara is an all-in-one GPS, ELD, AI-powered dash cams, telematics, maintenance, routing, and driver app. The City of Flint began using Samsara's services with the Streets department for GPS monitoring and dash cams for the plow truck division. We expanded our use and installed GPS tracking throughout our fleet of vehicles and equipment. We then took the programing and step further and began using it to complete and compile our monthly utilization reporting because its accuracy rate was 100% spot on.

PROCUREMENT (MUST BE SPECIFIED)

Please specify how this vendor was identified: (Check one)

- Sole Source (Please attach sole source statement to requisition)
- Competitive Bid Process (Please attach bid tabulation/documents to requisition)
- Cooperative Contract (MIDeal, Sourcewell, GSA, or other municipality)
 - *Contract must be attached to your requisition and contract must appear on the vendor's quote for goods/services
- (3) Quotes (please attach all quotes to your requisition)



STAFF REVIEW FORM

Effective: April 1, 2026

(Do not alter or modify this form without written permission from the City Administrator)

Section 2. PREVIOUS ALLOCATIONS (INCLUDE ALL ACCOUNTS USED FOR THIS PURPOSE)/ PROVIDE RESOLUTION OR CONTRACT INFORMATION THAT APPLIES..

Fiscal Year	Account	PO Number	FY PO Amount	FY Expensed	Resolution
Fy25	661-229.000-814.600	25-007993	\$38,198.83	\$38,198.83	N/A
Fy26	661-229.000-814.600	26-008882	\$36,645.83	\$36,645.83	N/A
Fy26	661-229.000-814.600	26-009194	\$38,979.46	\$38,979.46	N/A
Fy26	661-229.000-814.600	26-009182	\$2,326.50	\$2,326.50	N/A
Fy26	661-229.000-814.600	26-009341	\$1,491.25	\$1,491.25	N/A

25-007993 Software fee
 26-008882 Software fee
 26-009194 Software fee
 26-009182 License for 3 months (align us with fiscal year)
 26-009341 GPS Equipment purchase

Section 3. POSSIBLE BENEFIT TO THE CITY OF FLINT (RESIDENTS AND/OR CITY OPERATIONS) INCLUDE PARTNERSHIPS AND COLLABORATIONS..

The purpose of vehicle GPS tracking and camera recording in fleet operations is to monitor the real-time location of company vehicles, allowing managers and foreman to optimize routes, improve driver behavior, track vehicle usage, and ultimately enhance operational efficiency by making data-driven decisions regarding vehicle dispatch, maintenance, and fuel consumption, essentially providing complete visibility into fleet activity to reduce costs and improve productivity. We have also been able to record video footage of incidents which are essential for (HR) human resources and legal department issues.

Section 4. FINANCIAL IMPLICATIONS..

IF ARPA related Expenditure:

Has this request been reviewed by E&Y Firm: YES NO IF NO, PLEASE EXPLAIN:

NOTE: Accountant MUST include the following information:

- What is the total amount budgeted for this purpose?
- What percentage is being spent with this vendor?
- What is the justification for spending this amount of money with this vendor?



STAFF REVIEW FORM

Effective: April 1, 2026

(Do not alter or modify this form without written permission from the City Administrator)

- What percentage is being spent out of each line item used in this request?
- List all the known budgeted funds from that line item.

Our renewal fee has come due; contract terms are for 36 months (3 years)
 The Total amount budgeted for this purpose: \$278,262.24 with a \$92,754.08 annual fee
 The percentage being spent with this vendor: 100%
 Justification for spending this amount of money with this vendor: To pay our annual subscription fee to maintain access to the GPS telematics system
 Percentage being spent out of each line item used: 100% of \$278,262.24 billed in installments of \$92,754.08 annually

BUDGETED EXPENDITURE? YES NO IF NO, PLEASE EXPLAIN:

Dept.	Name of Account	Account Number	Grant CODE	Amount
3331	Computer Software	661-229.000-814.600	N/A	\$92,754.00
FY26 GRAND TOTAL				\$92,754.00

WHEN APPLICABLE, IF MORE THAN ONE (1) YEAR, PLEASE ESTIMATE TOTAL AMOUNT FOR EACH BUDGET YEAR: (This will depend on the term of the bid proposal)

BUDGET YEAR 1: \$92,754.08
 BUDGET YEAR 2: \$92,754.08
 BUDGET YEAR 3: \$92,754.08

OTHER IMPLICATIONS (i.e., collective bargaining).. _____

PRE-ENCUMBERED? YES NO REQUISITION NO: 26-0011435

ACCOUNTING APPROVAL:  Date: _____
Jo Janski (May 5, 2026 11:13:16 EDT)

WILL YOUR DEPARTMENT NEED A CONTRACT? YES NO

Section 5. RESOLUTION DEFENSE TEAM...

(Place the names of those who can defend this resolution at City Council)



STAFF REVIEW FORM

Effective: April 1, 2026

(Do not alter or modify this form without written permission from the City Administrator)

	NAME	PHONE NUMBER
1	Marquita Blair	810.423.5650
2		
3		
4		

STAFF RECOMMENDATION: (PLEASE SELECT): APPROVED NOT APPROVED

DEPARTMENT HEAD SIGNATURE: Marquita Blair, Fleet Administrator
(Name, Title)

ADMINISTRATION APPROVAL: 
Clyde Edwards (May 5, 2026 12:29:01 EDT)
(\$20,000 or above spending authorizations)

Section 6. VENDOR EVALUATION..

Business Title: Samsara Inc	Vendor ID: 0008579
Review Period:	Department: Fleet Department
Project Name: Samsara 36 month Renewal	Project Type: Subscription fee

Vendor Goals:

For the use of Samsara's telematics to continue to increase the safety, efficiency and sustainability of the physical operations throughout the City of Flint vehicles and equipment. Samsara enables us to ensure compliance, be alerted of accidents, and improve upon preventative maintenance.

1 = Poor 2 = Fair 3 = Sufficient 4 = Good 5 = Excellent

Job Knowledge:



STAFF REVIEW FORM

Effective: April 1, 2026

(Do not alter or modify this form without written permission from the City Administrator)

Work Quality:	<input type="checkbox"/>	<input type="checkbox"/>	<input type="checkbox"/>	<input type="checkbox"/>	<input checked="" type="checkbox"/>
Timeliness:	<input type="checkbox"/>	<input type="checkbox"/>	<input type="checkbox"/>	<input type="checkbox"/>	<input checked="" type="checkbox"/>
Compliance with Contract:	<input type="checkbox"/>	<input type="checkbox"/>	<input type="checkbox"/>	<input type="checkbox"/>	<input checked="" type="checkbox"/>
Warranty (If Product):	<input type="checkbox"/>	<input type="checkbox"/>	<input type="checkbox"/>	<input type="checkbox"/>	<input checked="" type="checkbox"/>
Responsiveness:	<input type="checkbox"/>	<input type="checkbox"/>	<input type="checkbox"/>	<input type="checkbox"/>	<input checked="" type="checkbox"/>
Cost Effectiveness:	<input type="checkbox"/>	<input type="checkbox"/>	<input type="checkbox"/>	<input type="checkbox"/>	<input checked="" type="checkbox"/>
Dependability:	<input type="checkbox"/>	<input type="checkbox"/>	<input type="checkbox"/>	<input type="checkbox"/>	<input checked="" type="checkbox"/>
Total Performance:	<input type="checkbox"/>	<input type="checkbox"/>	<input type="checkbox"/>	<input type="checkbox"/>	<input checked="" type="checkbox"/>
Overall Rating:	<input type="checkbox"/>	<input type="checkbox"/>	<input type="checkbox"/>	<input type="checkbox"/>	<input checked="" type="checkbox"/>

DEFECTS (IF ANY): IF CHECKED, PLEASE EXPLAIN:

N/A no defect to report

Performance / Other Comments:

Samsara has proven to be very resourceful. The convenience of having a single interface for all our data is so important. Samsara makes it easier to keep track of our equipment, and improve efficiency across the board. Their website is user-friendly, the department heads and foreman throughout the City of Flint all use Samsara. Their customer support has been a big help with troubleshooting and Q&A.

As the Fleet manager, Samara helps me make date-driven decisions. Having centralized data from telematics, dash cams, GPS tracking, fuel cards, and maintenance logs, and more enables me to make smarter, more informed decisions. I can easily view cost drivers and performance trends, in real time.

REVIEWER'S SIGNATURE:

Addy Schiller

Addy Schiller (May 5, 2026 10:57:34 EDT)

Date:

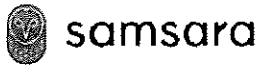

Thank you for considering Samsara

Samsara provides real-time visibility, business-relevant tools, and powerful analytics that enable customers to increase the productivity of their fleets and reduce operating costs. A solution for your fleet is proposed below.

What is included?

Samsara's fleet tracking solution includes hardware accessories and a per-gateway license. Gateway licenses provide all ongoing elements of the service, including:

- Real-time location and vehicle telematics
- Dashboard access with unlimited administrator accounts
- Driver App for iOS and Android devices with unlimited driver accounts
- Over-the-air software feature upgrades
- API access as it relates to features for integration with 3rd party systems
- Maintenance and phone support

Samsara does not include hidden costs in its licenses. If you want access to Samsara's full set of fleet features--including but not limited to WiFi hotspot and ELD capabilities--you will need to upgrade your license. Samsara reserves the right to audit usage of features unrelated to the solution as well as remove them from the Samsara Dashboard.

Payment Terms

This order form includes a license fee for the Samsara Software associated with the Hardware to be paid upfront beginning on the License Start Date and, if applicable, a one-time Hardware cost to be paid upfront as of the License Start Date. All transfers made by credit card are subject to a processing fee up to 3%, subject to applicable law. Late payments are subject to a 1.5% per month late fee. If license payments are delinquent by 30 days, Samsara may suspend the Service until late payments are remitted.

License Term

The license term for the Samsara Software licenses purchased under this Order Form begins on the day Samsara activates the applicable Samsara Software license by providing you a claim number and access to the Hosted Software ("License Start Date"). If Hardware associated with a then-unactivated Samsara Software license will be shipped to you under this Order Form, such Samsara Software license will be activated on the day the Samsara Hardware ships.

Notwithstanding the foregoing, if you are renewing the license term for a previously-activated Samsara Software license under this Order Form, the License Start Date for the renewal license term shall be the day that Samsara extends your access to the Hosted Software for the renewal license term. Samsara Hardware requires a valid license to function.

Samsara may ship Hardware under this Order Form subject to a schedule as mutually agreed between the Parties or as determined by Samsara. By signing this Order Form, you confirm that each "Ship To" delivery address set forth herein is accurate and that any individual accepting delivery at that address is authorized to do so on your behalf. To the extent such Hardware is associated with then-unactivated Samsara Software licenses, the Samsara Software license

Samsara Inc.

1 De Haro Street, San Francisco, CA 94017 • samsara.com

term for each such Hardware device will start on the day that device ships regardless of the shipment schedule for the other such Hardware devices. If all such Hardware is shipped in one shipment, the license term for all such Hardware will be the full license term under this Order Form. If such Hardware is shipped in multiple shipments, only the license term of such Hardware in the initial shipment will be such full license term. The license term of the remaining such Hardware shipped after the initial shipment will be set to match the then-remaining license term of the initial shipment, so that the license term for all such Hardware under this Order Form expires on the same date. The total cost of the licenses for such Hardware shipped after the initial shipment will be pro-rated based on their actual license term, rounded up to the nearest month, as compared to the full license term under this Order Form. Certain payment amounts under this Order Form assume that the entire order is fulfilled at the same time and are subject to potential reduction based on the actual schedule of order fulfillment.

You agree that you will only use the features included with the Samsara Software licenses purchased under this Order Form ("Licensed Scope"). Samsara reserves the right to audit usage of Samsara Software and to remove your access to such features beyond the Licensed Scope (for example, the licensed feature scope or licensed user count, as applicable) at any time. If you would like to use features beyond the Licensed Scope, you are required to purchase the applicable Samsara Software licenses and if applicable install the applicable Hardware that include such scope. If Samsara becomes aware that you are using features beyond the Licensed Scope, Samsara reserves the right to charge you for the applicable Samsara Software licenses that include such Licensed Scope at list price, and you agree to immediately pay such amounts. Samsara further reserves the right to change, discontinue, or remove features included in a Samsara Software license at any time.

You acknowledge and agree that, during your license term, you may not downgrade your Samsara Software license plan to a lower Samsara Software license plan (e.g., downgrading your "Enterprise" license to a "Premier" license).

Support And Warranty

Samsara stands behind its Products. During the applicable warranty period, defective Hardware will be remedied pursuant to our Hardware Warranty Policy at www.samsara.com/support/hardware-warranty. Additional support information can be found at www.samsara.com/support.

Terms

Unless otherwise set forth herein, your use and access of the Hardware, Products, and Services specified herein are governed by Samsara's standard terms of service found at <https://www.samsara.com/legal/public-sector-customers-platform-terms-of-service/>, unless the Parties have entered into a separate terms of service agreement and/or a separate terms of service agreement is attached to the Order Form, in which case such separate terms of service agreement shall govern (the "Terms of Service") provided that notwithstanding anything stated in the Terms of Service to the contrary, Customer agrees the following sections from Samsara's standard terms of service found at <https://www.samsara.com/legal/public-sector-customers-platform-terms-of-service/> shall apply: License (Section 4), Product Updates (Section 7), Data Protection Addendum (Section 10.3), Non-Samsara Products (Section 14), and Hardware Warranty (Section 17). You agree to be bound by the Terms of Service, and any capitalized terms not defined herein shall have the meaning set forth in the Terms of Service. The terms and conditions of the Terms of Service and this Order Form are the exclusive agreement of the parties with respect to the subject matter hereof and no other terms or conditions, including those associated with any Customer payment portal or onboarding of Samsara as a Customer

Samsara Inc.

1 De Haro Street, San Francisco, CA 94017 • samsara.com



vendor, shall be binding upon Samsara or otherwise have any force or effect.

To the extent Samsara allows you to make subsequent purchases of Products via Purchase Order without a corresponding Quote, you agree that (i) such Purchase Order shall be subject to the terms and conditions of this Order Form, including with respect to payment and license terms, as well as the applicable Terms of Service; and (ii) to the extent there is a conflict between such Purchase Order and this Order Form, including with respect to payment and license terms, as well as the applicable Terms of Service, the terms of this Order Form shall prevail, and no additional terms included in such Purchase Order that are not included in this Order Form shall apply. You acknowledge and agree that any reference to a Purchase Order in this Order Form is solely for your convenience in record keeping, and the existence of a Purchase Order or any delivery of Products to you following receipt of any Purchase Order shall not be deemed an acknowledgement of or agreement to any terms or conditions associated with any such Purchase Order or in any way be deemed to modify, alter, supersede or supplement the Terms of Service or this Order Form.

Notwithstanding anything to the contrary in the Samsara Terms of Service, this Order Form shall not automatically renew at the end of the applicable Samsara Software license term.

Samsara Inc.

1 De Haro Street, San Francisco, CA 94017 • samsara.com



Notification of Confidentiality

You agree that the pricing and payment terms specified in this Order Form shall (i) be held in strict confidence; (ii) not be disclosed to any Samsara competitor or other entity, except as pre-approved in writing by Samsara; and (iii) not be used except to evaluate the suitability of the Samsara Products for your business. You will immediately notify Samsara in the event of any unauthorized use or disclosure under these terms. Violation of these obligations will cause irreparable harm to Samsara for which Samsara may obtain compensatory and timely injunctive relief from a court, as well as any other remedies that may be available, including recovery of all reasonable attorney's fees and costs incurred in seeking such remedies. Your obligations specified herein shall last until the pricing and payment terms herein are, through no fault or action by you, public. This Order Form is a legally binding agreement between you ("Customer") and Samsara Inc. ("Samsara"). IN WITNESS WHEREOF, Customer has caused this Order Form to be executed by its duly authorized representative.

Samsara Inc.

1 De Haro Street, San Francisco, CA 94017 • samsara.com



The Connected Operations Cloud

I confirm acceptance of this Order Form on behalf of the Customer identified herein and represent and warrant that I have full and complete authority to bind the Customer to this Order Form, including all terms and conditions herein." "Please confirm acceptance of this Order Form by signing below:

Signature

Print Name:

Date:



Quote #: Q-2555162

Issued Date: 03-26-2026
Expires: 04-10-2026
Order Number: S-2741267

Payment Information:
Payment Method: Credit Card/ACH Debit
Payment Terms: Net 60
Payment Frequency: Direct Annual
Estimated Ship Date: 07-09-2026

Prepared For:

City Of Flint
1101 S Saginaw
Flint,
Michigan
48502

Prepared By:

Alyssa Toma
alyssa.toma@samsara.com

Cost Overview

License Term: 36 Months

Total License Cost over 36 Months	USD \$278,262.24
Hardware and Accessories	Included
Shipping and Handling*	USD \$0.00
Total Sales Tax*	USD \$0.00
Total Contract Value ¹	\$278,262.24
First Invoice ¹	\$92,754.08
Recurring Invoice ²	\$92,754.08

¹Estimated value, actual invoice amount may change based on product fulfillment date. Includes estimated sales tax.

²Amount allocated to for products purchased in this order only. Includes estimated sales tax.

*If shipping is "Pending" - Amount is pending due to size of order. Shipping and handling subject to change.

³Sales tax subject to change. If sales tax is "Pending" - Final amount will be provided prior to payment.

3% fee only applies to US - (CAD, MX, EMEA are exempt)



The Connected Operations Cloud

Product Overview

Samsara Inc.

1 De Haro Street, San Francisco, CA 94017 • samsara.com

Licenses	Annual Unit Price	Total Annual Price
License for Vehicle Gateways - Public Sector Only, No WiFi, No ELD LIC-VG-PS-QTY: 320	\$224.05	\$71,696.00
Plus License for Powered Asset Gateways LIC-AG-PWR-PLUS-QTY: 51	\$209.36	\$10,677.36
License for Vehicle Gateways LIC-VG-ENT-QTY: 14	\$372.24	\$5,211.36
License for Forward-Facing Dash Camera LIC-CM1-ENT-QTY: 11	\$372.24	\$4,094.64
License for Rear Camera LIC-MC-R-QTY: 2	\$72.36	\$144.72
Live Streaming LIC-CM-STRM-QTY: 1	\$66.00	\$66.00
License for AI Multicam LIC-MC-AIM4-QTY: 1	\$480.00	\$480.00
License for Dual-Facing Camera LIC-CM2-ENT-QTY: 1	\$384.00	\$384.00
Total Price:		\$92,754.08



The Connected Operations Cloud

Billing Details:

Bill To:
City Of Flint
1101 S Saginaw
Flint, Michigan, 48502

Billing Contact:
Name: Lauren Rowley
Title: Purchasing Manager
Billing Email:
accounts payable@cityofflint.com
Phone Number: 8107667266

Does your organization require a purchase order (PO) in order to process payment to vendors?

If yes, please provide the PO Number:

If your organization requires invoice submission via an electronic invoice portal, please email any e-invoicing requirements to billingsupport@samsara.com.

Please email any tax documentation to billingsupport@samsara.com.

Samsara Inc.

1 De Haro Street, San Francisco, CA 94017 • samsara.com

Entity Type	Foreign Profit Corporation
Entity Status	Active
AR Standing	Good
Common Shares	5800000000
AR Due Date	05/15/2026
Initial Filing Date	04/01/2024
Last Report with Officers and Directors	2025
Total Authorized Shares	5800000000
Shares Attributable to Michigan	136004200
Current Period Apportionment %	2.3449
Current Period % Year End	2024
Resident Agent Name	C T CORPORATION SYSTEM

wing 1 - 2 of 2 results

MSARA INC. ● Active Registration

Entity

Unique Entity ID: CX1HPVJX5
CAGE Code: 7NXLS
Physical Address: 1 DE HARO ST, SAN FRANCISCO, CA 94103 USA

Expiration Date: Feb 27, 2027

Purpose of Registration: All Awards

MSARA INC.



Intract ID (PIID): GS35F327GA

Modification Number: PSA914 Reason for Modification: OTHER ADMINISTRATIVE ACTION

airdee

Details

Contracting Agency

Unique Entity ID: CX1HPVJX5

Award/IDV Type: FEDERAL SUPPLY SCHEDULE

Total Dollars Obligated: \$0.00

Department/Ind. Agency: 4700 - GENERAL SERVICES ADMINISTRATION

E/INCAGE: JL5

Date Signed: May 6, 2026

Total Contract Value: \$7,680,375.00

Subtier: 4732 - FEDERAL ACQUISITION SERVICE

Office:

47QTCA - GSA/FAS CENTER FOR IT SCHEDULE PROG

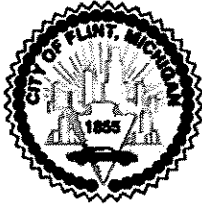

260217

RESOLUTION NO.: _____

PRESENTED: 6-17-2026

ADOPTED: _____

BY THE CITY ADMINISTRATOR:

**RESOLUTION TO AUTHORIZE SPENDING AND PURCHASE OF PORTABLE RADIOS,
BATTERIES AND CHARGERS IN THE AMOUNT OF \$108,815.25 FOR THE
FLINT FIRE DEPARTMENT**

WHEREAS, the Flint Fire Department will be utilizing Motorola Solutions, Inc., a MiDeal Contract to purchase 15 portable radios, portable batteries and 10 desktop chargers for use in fire suppression.

WHEREAS, portable radios are an emergent need for Flint Firefighters to effectively communicate while on emergency scenes, enhancing safety while searching and performing various fireground operations.

WHEREAS, the Flint Fire Department is requesting that Flint City Council approve funding in the amount of \$108,815.25 to Motorola Solutions, Inc., MiDeal Contract No. 190000001544 for the purchase of portable radios, portable batteries and desktop chargers.

Funding is to come from the following Fire Department account

GL/ACCOUNT #	ACCOUNT NAME/GRANT CODE	AMOUNT
101-336.000-977.000	EQUIPMENT	\$108,815.25
	FY27 Grand Total	\$108,815.25

IT IS RESOLVED, that the appropriate City Officials are hereby authorized to do all things necessary, to approve spending from funding source account 101-336.000-977.000 in the amount of \$108,815.25.

BE IT FURTHER RESOLVED, that the Division of Purchases and Supplies is hereby authorized to issue a Purchase Order to Motorola Solutions, Inc. in an amount Not-to-Exceed \$108,815.25 for the purchase of 15 portable radios, batteries and 10 desktop chargers.

APPROVED AS TO FORM:

JoAnne Gurley (Jun 9, 2026 21:55:39 EDT)

JoAnne Gurley, City Attorney

APPROVED AS TO FINANCE:

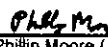
Phillip Moore (Jun 10, 2026 07:21:10 EDT)

Phillip Moore, Chief Financial Officer

FOR THE CITY OF FLINT:

Clyde Edwards / A0676 (Jun 10, 2026 11:58:57 EDT)

Clyde Edwards, City Administrator

APPROVED BY CITY COUNCIL:

APPROVED AS TO PURCHASING:

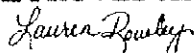

Lauren Rowley, Purchasing Manager



STAFF REVIEW FORM

Effective: April 1, 2026

(Do not alter or modify this form without written permission from the City Administrator)

TODAY'S DATE: June 9, 2026

BID PROPOSAL #: _____

AGENDA ITEM TITLE: Motorola APX6000 Portable Radios with Portable Batteries and Desktop Single Chargers

PREPARED BY: Karen Shim, Flint Fire Department

VENDOR NAME: Motorola Solutions, Inc.

Section 1. BACKGROUND/SUMMARY OF PROPOSED ACTION..

Vendor Compliance (This vendor has been properly vetted and the responses are below) :

Federal gov't	(All documentation current, no violations)	<input checked="" type="checkbox"/> YES	<input type="checkbox"/> NO
State gov't	(All documentation current, no violations)	<input checked="" type="checkbox"/> YES	<input type="checkbox"/> NO
City of Flint	(All documentation current, no violations)	<input checked="" type="checkbox"/> YES	<input type="checkbox"/> NO

The requesting authority is validating that this vendor has been in full compliance with all past contract provisions and has not violated the terms of any contract with the City of Flint.

NOTE: Preparer MUST include a response to the conditions below:

- Did we do an assessment of first consideration to internal City of Flint staff and resources (explain)?
- Why was this vendor chosen?
- What history does this vendor have with the City of Flint?
- What steps will be taken to do a post-performance of the vendor?

An assessment of first consideration to internal City of Flint staff was completed on April 30, 2026 and May 4, 2026, by Flint Fire Chief Theron S. Wiggins and his Command Staff. Discussion revealed the urgent need for portable radios with portable batteries and desktop single chargers. Discussion included a review of funding and that resources are available to purchase 15 APX6000 portable radios with portable batteries and 10 desktop single chargers. Motorola Solutions, Inc. is the chosen vendor because they are the global leader in public safety and enterprise technology. They specialize in three primary areas, Critical Communications: Land mobile radio devices and networks, such as the APX and MOTOTRBO series, designed for mission-critical use by first responders and industrial workers, Video Security & Access Control and Command Center Software. The City of Flint has close to a decade of history and experience doing business with this vendor. Post performance steps to be taken will be to monitor the amount of time to receive ordered goods and the availability of customer service representatives and Motorola service technicians should any equipment fail or need repairing in the early stages after ordering. The Flint Fire Department have always received discounted pricing and excellent service from Motorola Solutions, Inc.

With a rich history of innovation since 1928, the mission of Motorola Solutions Inc. is to advance safety and security globally through an ecosystem of technologies that helps protect people, property and places. Motorola Solutions, Inc. (MSI) is a global leader in public safety and enterprise security technology, headquartered in Chicago, Illinois. Formed in 2011 after the split of the original Motorola, Inc., it serves as the legal successor to the parent company, while the mobile phone division (Motorola Mobility) was eventually acquired by Lenovo.



STAFF REVIEW FORM

Effective: April 1, 2026

(Do not alter or modify this form without written permission from the City Administrator)

Motorola Solutions, Inc. builds and connects technologies to help protect people, property and places, enabling critical collaboration between public safety agencies and enterprises for a proactive approach to safety and security of nearly 100 years. Motorola Solutions, Inc. is one of the most trusted companies in America according to Forbes 2025. (Source: motorolasolutions.com)

Summary of Proposed Action:

The Flint Fire Department is requesting approval of a purchase order in the amount of \$108,815.25 to Motorola Solutions Inc., MI Deal Contract No. 190000001544 to purchase 15 APX6000 portable radios with portable Batteries and 10 single desktop chargers needed in fire suppression.

PROCUREMENT (MUST BE SPECIFIED)

Please specify how this vendor was identified: (Check one)

- Sole Source (Please attach sole source statement to requisition)
- Competitive Bid Process (Please attach bid tabulation/documents to requisition)
- Cooperative Contract (MIDeal, Sourcewell, GSA, or other municipality)
 - *Contract must be attached to your requisition and contract must appear on the vendor's quote for goods/services
- (3) Quotes (please attach all quotes to your requisition)

Section 2. PREVIOUS ALLOCATIONS (INCLUDE ALL ACCOUNTS USED FOR THIS PURPOSE)// PROVIDE RESOLUTION OR CONTRACT INFORMATION THAT APPLIES..

Fiscal Year	Account	PO Number	FY PO Amount	FY Expensed	Resolution
2026	101-336.000-977.000	26-009230	\$70,616.00	\$70,616.00	N/A
2026	101-336.000-977.000	26-009392	\$21,335.89	\$21,335.89	N/A

The Flint Fire Department had two previous allocations directly with the vendor, Motorola Solutions, Inc.

Section 3. POSSIBLE BENEFIT TO THE CITY OF FLINT (RESIDENTS AND/OR CITY OPERATIONS) INCLUDE PARTNERSHIPS AND COLLABORATIONS..

The benefit to City Operations and City of Flint residents is that having a portable radio allows a firefighter to immediately report or be notified of emergency conditions such as a missing or injured firefighter or potential or impending structural collapse or hazardous conditions. It enhances safety, allowing firefighters to call for



STAFF REVIEW FORM

Effective: April 1, 2026

(Do not alter or modify this form without written permission from the City Administrator)

immediate help in emergencies if they are trapped or in immediate danger. Portable radios enable effective teamwork by allowing firefighters to communicate with each other, station officers and Battalion Chief to coordinate tactics and deploy resources efficiently. Effective communication can mean the difference between life and death. The ability to communicate clearly and reliably is not only convenient; it is totally vital for saving lives.

Section 4. FINANCIAL IMPLICATIONS..

IF ARPA related Expenditure:

Has this request been reviewed by E&Y Firm: YES NO IF NO, PLEASE EXPLAIN:

NOTE: Accountant MUST include the following information:

- What is the total amount budgeted for this purpose?
- What percentage is being spent with this vendor?
- What is the justification for spending this amount of money with this vendor?
- What percentage is being spent out of each line item used in this request?
- List all the known budgeted funds from that line item.

The total amount budgeted for this purpose is \$108,815.25. (Quote 3613108 for \$71,420.00 and Quote 3617477 for \$37,395.25). The percentage being spent with this vendor is 23.8%. The justification for spending this amount with the vendor is the critical emergent need to purchase 15 portable radios with batteries and 10 desktop single chargers for firefighters' effective radio communication in emergency response operations. The total amount currently spent on each line item is a total of 51.6% and does not include the 23.8% for the purchase of 15 portable radios, batteries and 10 single desktop chargers. Budgeted funds for all line items from the below named GL account are derived from the General Fund.

BUDGETED EXPENDITURE? YES NO IF NO, PLEASE EXPLAIN:

Dept.	Name of Account	Account Number	Grant CODE	Amount
Fire	Equipment	101-336.000-977.000		\$108,815.25
FY26 GRAND TOTAL				\$108,815.25

WHEN APPLICABLE, IF MORE THAN ONE (1) YEAR, PLEASE ESTIMATE TOTAL AMOUNT FOR EACH BUDGET YEAR: (This will depend on the term of the bid proposal)

BUDGET YEAR 1: _____



STAFF REVIEW FORM

Effective: April 1, 2026

(Do not alter or modify this form without written permission from the City Administrator)

BUDGET YEAR 2: _____

BUDGET YEAR 3: _____

OTHER IMPLICATIONS (i.e., collective bargaining).. _____

PRE-ENCUMBERED? YES NO REQUISITION NO: 260011594

ACCOUNTING APPROVAL: Karen Shim Date: June 9, 2026

WILL YOUR DEPARTMENT NEED A CONTRACT? YES NO

Section 5. RESOLUTION DEFENSE TEAM..

(Place the names of those who can defend this resolution at City Council)

	NAME	PHONE NUMBER
1	Frederick Presswood	810-762-7336
2	Theron S. Wiggins	810-762-7336
3		
4		

STAFF RECOMMENDATION: (PLEASE SELECT): APPROVED NOT APPROVED

DEPARTMENT HEAD SIGNATURE: _____

Frederick Presswood
Frederick Presswood (Jun 9, 2026 15:23:24 EDT)

Frederick Presswood, Deputy Chief

ADMINISTRATION APPROVAL:
(\$20,000 or above spending authorizations)

Clyde Edwards
Clyde Edwards (Jun 9, 2026 15:59:01 EDT)



STAFF REVIEW FORM

Effective: April 1, 2026

(Do not alter or modify this form without written permission from the City Administrator)

Section 6. VENDOR EVALUATION..

Business Title:

Motorola Solutions
Inc

Vendor ID:

0000000684

Review Period:

06/02/26 –
06/30/26

Department:

Fire

Project Name:

APX6000 Portable
Radios and
Desktop Single
Chargers

Project Type:

Emergency Response

Vendor Goals:

The vendor goals expected with Motorola Solutions, Inc are as follows:

1. Delivery time of APX6000 portable radios, batteries and desktop chargers
2. Effective and responsive communication with the vendor and/or their technicians
3. Available to provide emergency repair support for Motorola equipment
4. Adheres to contractual requirements (MI Deal Contract No. 190000001544)
5. Maintain business partnership with Motorola Solutions Inc and City of Flint Municipality

	1 = Poor	2 = Fair	3 = Sufficient	4 = Good	5 = Excellent
Job Knowledge:	<input type="checkbox"/>	<input type="checkbox"/>	<input type="checkbox"/>	<input type="checkbox"/>	<input checked="" type="checkbox"/>
Work Quality:	<input type="checkbox"/>	<input type="checkbox"/>	<input type="checkbox"/>	<input type="checkbox"/>	<input checked="" type="checkbox"/>
Timeliness:	<input type="checkbox"/>	<input type="checkbox"/>	<input type="checkbox"/>	<input type="checkbox"/>	<input checked="" type="checkbox"/>
Compliance with Contract:	<input type="checkbox"/>	<input type="checkbox"/>	<input type="checkbox"/>	<input type="checkbox"/>	<input checked="" type="checkbox"/>
Warranty (If Product):	<input type="checkbox"/>	<input type="checkbox"/>	<input type="checkbox"/>	<input type="checkbox"/>	<input checked="" type="checkbox"/>
Responsiveness:	<input type="checkbox"/>	<input type="checkbox"/>	<input type="checkbox"/>	<input type="checkbox"/>	<input checked="" type="checkbox"/>



STAFF REVIEW FORM

Effective: April 1, 2026

(Do not alter or modify this form without written permission from the City Administrator)

Cost Effectiveness:	<input type="checkbox"/>	<input type="checkbox"/>	<input type="checkbox"/>	<input type="checkbox"/>	<input checked="" type="checkbox"/>
Dependability:	<input type="checkbox"/>	<input type="checkbox"/>	<input type="checkbox"/>	<input type="checkbox"/>	<input checked="" type="checkbox"/>
Total Performance:	<input type="checkbox"/>	<input type="checkbox"/>	<input type="checkbox"/>	<input type="checkbox"/>	<input checked="" type="checkbox"/>
Overall Rating:	<input type="checkbox"/>	<input type="checkbox"/>	<input type="checkbox"/>	<input type="checkbox"/>	<input checked="" type="checkbox"/>

DEFECTS (IF ANY): IF CHECKED, PLEASE EXPLAIN:

Performance / Other Comments:

The vendor is responsive, maintains excellent communication and provides support for the Flint Fire Department's radio communication needs and maintenance repairs.

REVIEWER'S SIGNATURE:

Karen Shim

Date:

June 9, 2026



STATE OF MICHIGAN
CENTRAL PROCUREMENT SERVICES
 Department of Technology, Management, and Budget
 525 W. ALLEGAN ST., LANSING, MICHIGAN 48913
 P.O. BOX 30026 LANSING, MICHIGAN 48909

CONTRACT CHANGE NOTICE

Change Notice Number **2**
 to
 Contract Number **190000001544**

CONTRACTOR	MOTOROLA SOLUTIONS INC	STATE	Kate Jannereth	DTMB
	500 W. Monroe St.		517-881-1031	
	Chicago, IL 60661		jannerethk@Michigan.gov	
	Melanie Leenhouts		Valerie Hiltz	DTMB
	616-706-1723		(517) 249-0459	
	melanie.leenhouts@motorolasolutions.com		hiltzv@michigan.gov	
CV0016903				

CONTRACT SUMMARY

MPSCS CONTINUED SYSTEM UPDATES, EQUIPMENT, MAINTENANCE AND UPGRADES, AND ANCILLARY SYSTEMS PRODUCTS

INITIAL EFFECTIVE DATE	INITIAL DURATION DATE	INITIAL AVAILABLE OPTIONS	EXPIRATION DATE
October 1, 2019	December 31, 2029	0 - 0 Year	December 31, 2029
PAYMENT TERMS		DELIVERY TIMEFRAME	
NET 45		As per Delivery Order	
ALTERNATE PAYMENT OPTIONS			EXTENDED PURCHASING
<input type="checkbox"/> P-Card	<input type="checkbox"/> PRC	<input type="checkbox"/> Other	<input checked="" type="checkbox"/> Yes <input type="checkbox"/> No
MINIMUM DELIVERY REQUIREMENTS			
N/A			

DESCRIPTION OF CHANGE NOTICE

REASON	DESCRIPTION	DATE
<input type="checkbox"/>		December 31, 2029
CURRENT VALUE	VALUE OF CHANGE NOTICE	ESTIMATED APROX. CONTRACT VALUE
\$99,900,000.00	\$0.00	\$99,900,000.00

DESCRIPTION

Effective July 1, 2021 this contract is adding scope to Schedule A via Attachment 10- Critical Connect Subscription Service, adding Schedule H- Subscription Services Schedule, and updating Schedule B, all as attached.

All other terms, conditions, specifications and pricing remain the same. Per Contractor and Agency agreement and DTMB Central Procurement Services approval.



STATE OF MICHIGAN PROCUREMENT

DTMB Central Procurement Services

525 W. Allegan Street, 1st Floor NE
Lansing, MI 48933

NOTICE OF CONTRACT

NOTICE OF CONTRACT NO. **190000001544**

between

THE STATE OF MICHIGAN

and

CONTRACTOR	Motorola Solutions, Inc
	500 W. Monroe St.
	Chicago, IL 60661
	Rich Uslan
	616-438-1942
	rich.uslan@motorolasolutions.com
	CV0016903

STATE	Kate Jannereth	DTMB
	517-881-1031	
	jannerethk@michigan.gov	
	Valerie Hiltz	DTMB
	517-249-0459	
	hiltzv@michigan.gov	

CONTRACT SUMMARY			
DESCRIPTION: Michigan's Public Safety Communications System (MPSCS) Continued System Updates, Equipment, Maintenance and Upgrades, and Ancillary Systems Products			
INITIAL EFFECTIVE DATE	INITIAL EXPIRATION DATE	INITIAL AVAILABLE OPTIONS	EXPIRATION DATE BEFORE CHANGE(S) NOTED BELOW
October 1, 2019	December 31, 2029	None	December 31, 2029
PAYMENT TERMS		DELIVERY TIMEFRAME	
Net 45		As per Delivery Order	
ALTERNATE PAYMENT OPTIONS			EXTENDED PURCHASING
<input checked="" type="checkbox"/> P-card <input type="checkbox"/> Payment Request (PRC) <input type="checkbox"/> Other			<input checked="" type="checkbox"/> Yes <input type="checkbox"/> No
MINIMUM DELIVERY REQUIREMENTS			
N/A			
MISCELLANEOUS INFORMATION			
<p>This Master Agreement Serves as an Order with regard to Maintenance and Support, for services as indicated in Schedule A, Section 4.1.A Price Terms and Section 5.1.A.1 Authorizing Document, and per terms, conditions and specifications of this contract.</p> <p>For all other Products and Services THIS IS NOT AN ORDER. Orders will be placed directly by the State Agency via the authorized document, established in Schedule A, Section 5.1.A.2 Authorizing Documents, and per terms, conditions and specification of this contract.</p>			
ESTIMATED CONTRACT VALUE AT TIME OF EXECUTION			\$99,900,000.00

FOR THE CONTRACTOR:

Motorola Solutions, Inc.
Company Name

Authorized Agent Signature

Authorized Agent (Print or Type)

Date

FOR THE STATE:

Signature

Jared Ambrosier, Enterprise Sourcing Director
Name & Title

DTMB, Central Procurement Services
Agency

September 26, 2019
Date



Department of Finance - Treasury

Sheldon Neeley
Mayor

Clyde Edwards
City Administrator

Good Standing Certification

Applicant and/or Business Clearance

All applicants for City of Flint funded programs, including federal programs, must remain current and not in default on any obligations related to taxes, fines, penalties, water service, licenses or other forms of penalties.

APPLICANT NAME: Motorola Solutions, Inc. (Agent Name: The Corporation Company)

HOME ADDRESS: 40600 Ann Arbor Rd E STE 201

DBA: _____

BUSINESS ADDRESS: Plymouth, MI 48170

Please include addresses of all properties in the name of other current and/or former businesses, parent company, subsidiaries and/or divisions. Also, please include all former names used while conducting business with the City.

This section to be completed by the Department of Finance - Customer Service Division

Please check the following divisions for the status of current and delinquent obligations owed to the City of Flint. Please circle the appropriate response for each division.

WATER DIV.
PROPERTY TAXES DIV.
INCOME TAX DIV.
ENFORCEMENT
MR

CURRENT
CURRENT
CURRENT
CURRENT
CURRENT

DELINQUENT No water in Name
DELINQUENT No prop in Name
DELINQUENT?
DELINQUENT } No acct in Name
DELINQUENT No acct in Name

If delinquencies exist, please indicate the date, type and amount of obligation:

Karen Shim , 1/20/2026
City Staff Person and Date

[Signature] 1/20/26
City of Flint Customer Serv. Representative and Date

FLINT FIRE DEPT. 1101 S. Saginaw St., FLINT, MICHIGAN 48902 (810) 700-7436

Business Search

As of 1/20/2026 we have processed all business filings received in our office through 01/13/2026.

To file a document or annual report/statement for an existing entity, search for the entity, select Request Access from the slide-out drawer, complete the questions, refresh the webpage, and select File Subsequent Document or File Annual Report/Statement.

The same process applies to order certificates and copies.

You must be logged in to file documents or order certificates and copies. Click on the Login button in the top right. If you do not have an account, create one. The credentials from the previous system did not transfer to this system.

Business Search Info:

Motorola Solutions

Advanced

Results: 3

Name	Filing Date	Status	AR Standing	Entity T.
MOTOROLA SOLUTIONS CONNECTIVITY, INC.	> 11/14/2013	Active	Good	Foreign Profit Corpora
MOTOROLA SOLUTIONS, INC.	> 05/09/1973	Active	Good	Foreign Profit Corpora
MOTOROLA SOLUTIONS VIDEO MANUFACTURING, INC.	> 07/10/2025	Active	Good	Foreign Profit Corpora

Entity Name	MOTOROLA SOLUTIONS, INC.
Prior Names	MOTOROLA, INC., MOTOROLA DELAWARE, INC.
Identification #	801008236
Jurisdiction	Delaware
Entity Type	Foreign Profit Corporation
Entity Status	Active
AR Standing	Good
Common Shares	600500000
AR Due Date	05/15/2026
Initial Filing Date	05/09/1973
Last Report with Officers and Directors	2025
Total Authorized Shares	600500000
Shares Attributable to Michigan	15038922
Current Period Apportionment	21003
Current Period Year End	2023
Resident Agent Name	THE CORPORATION COMPANY
Registered Office Street Address	40600 ANN ARBOR RD E STE 201, PLYMOUTH, MI 48170
President Name & Address	GREGORY BROWN 500 WEST MONROE STREET, CHICAGO, IL 60661
Secretary Name & Address	KRISTIN KRUSKA 500 WEST MONROE STREET, CHICAGO, IL 60661
Treasurer Name & Address	JASON WINKLER 500 WEST MONROE STREET, CHICAGO, IL 60661
Directors Names & Addresses	GREGORY Q. BROWN 500 WEST MONROE STREET, CHICAGO, IL 60661 JUDY LEWENT 500 WEST MONROE STREET, CHICAGO, IL 60661 KENNETH D. DENMAN 500 WEST MONROE STREET, CHICAGO, IL 60661 EGON P. DURBAN 500 WEST MONROE STREET, CHICAGO, IL 60661 CLAYTON M. JONES 500 WEST MONROE STREET, CHICAGO, IL 60661 GREGORY K. MONDRE 500 WEST MONROE STREET, CHICAGO, IL 60661 JOSEPH M. TUCCI 500 WEST MONROE STREET, CHICAGO, IL 60661 AYANNA M. HOWARD 500 WEST MONROE STREET, CHICAGO, IL 60661

Business Search

As of 6/2/2026

Business Filings are processed through 05/29/2026

Renewals and Restorations (for entities returning to good standing) are processed through 05/31/2026

To file a document or annual report/statement for an existing entity, search for the entity, select Request Access from the slide-out drawer, complete the questions, refresh the webpage, and select File Subsequent Document or File Annual Report/Statement.

The same process applies to order certificates and copies.

You must be logged in to file documents or order certificates and copies. Click on the Login button in the top right. If you do not have an account, create one. The credentials from the previous system did not transfer to this system.

Business Search Info:

Motorola Solutions

Advanced

Results: 3

Name	Filing Date	Status	AR Standing	Entity T
MOTOROLA SOLUTIONS CONNECTIVITY, INC.	11/14/2013	Active	Good	Foreign Profit Corpora
MOTOROLA SOLUTIONS, INC.	05/09/1973	Active	Good	Foreign Profit Corpora
MOTOROLA SOLUTIONS VIDEO MANUFACTURING, INC.	07/10/2025	Active	Good	Foreign Profit Corpora

Entity Name	MOTOROLA SOLUTIONS, INC.
Prior Names	MOTOROLA, INC., MOTOROLA DELAWARE, INC.
Identification #	801006236
Jurisdiction	Delaware
Entity Type	Foreign Profit Corporation
Entity Status	Active
AR Standing	Good
Common Shares	600500000
AR Due Date	06/15/2026
Initial Filing Date	05/09/1973
Last Report with Officers and Directors	2025
Total Authorized Shares	600500000
Shares Attributable to Michigan	15038822
Current Period Apportionment %	2.1003
Current Period % Year End	2023
Resident Agent Name	THE CORPORATION COMPANY
Registered Office Street Address	40600 ANN ARBOR RD STE 201, PLYMOUTH, MI 48170
President Name & Address	GREGORY BROWN 500 WEST MONROE STREET, CHICAGO, IL 60661
Secretary Name & Address	KRISTIN KRUSKA 500 WEST MONROE STREET, CHICAGO, IL 60661
Treasurer Name & Address	JASON WINKLER 500 WEST MONROE STREET, CHICAGO, IL 60661
Directors Names & Addresses	GREGORY Q. BROWN 500 WEST MONROE STREET, CHICAGO, IL 60661 JUDY LEWENT 500 WEST MONROE STREET, CHICAGO, IL 60661 KENNETH D. DENMAN 500 WEST MONROE STREET, CHICAGO, IL 60661 EGON P. DURBAN 500 WEST MONROE STREET, CHICAGO, IL 60661 CLAYTON M. JONES 500 WEST MONROE STREET, CHICAGO, IL 60661 GREGORY K. MONDRE 500 WEST MONROE STREET, CHICAGO, IL 60661 JOSEPH M. TUCCI 500 WEST MONROE STREET, CHICAGO, IL 60661 AYANNA M. HOWARD 500 WEST MONROE STREET, CHICAGO, IL 60661



Form Revision Date 07/201

ANNUAL REPORT
For use by FOREIGN PROFIT CORPORATION
(Required by Section 911, Act 284, Public Act of 1972)

The identification number assigned by the Bureau is: 801008236

Annual Report Filing Year: 2025

1. Corporation Name:

MOTOROLA SOLUTIONS, INC.

2. The street address of the corporation's registered office and the name of the resident agent at that office:

1. Resident Agent Name: THE CORPORATION COMPANY

2. Street Address: 40600 ANN ARBOR RD E STE 201

Apt/Suite/Other:

City: PLYMOUTH

State: MI

Zip Code: 48170

3. Mailing address of the corporation's registered office:

P.O. Box or Street
Address:

Apt/Suite/Other:

City:

State:

Zip Code:

4. Provide the names and business or residence addresses of the corporation's board of directors and its president, treasurer, and secretary:

Title	Name	Residence or Business Address
PRESIDENT	GREGORY BROWN	500 WEST MONROE STREET, CHICAGO, IL 60661 USA
TREASURER	JASON WINKLER	500 WEST MONROE STREET, CHICAGO, IL 60661 USA
SECRETARY	KRISTIN KRUSKA	500 WEST MONROE STREET, CHICAGO, IL 60661 USA
DIRECTOR	GREGORY Q. BROWN	500 WEST MONROE STREET, CHICAGO, IL 60661 USA
DIRECTOR	JUDY LEWENT	500 WEST MONROE STREET, CHICAGO, IL 60661 USA
DIRECTOR	KENNETH D. DENMAN	500 WEST MONROE STREET, CHICAGO, IL 60661 USA
DIRECTOR	EGON P. DURBAN	500 WEST MONROE STREET, CHICAGO, IL 60661 USA
DIRECTOR	CLAYTON M. JONES	500 WEST MONROE STREET, CHICAGO, IL 60661 USA
DIRECTOR	GREGORY K. MONDRE	500 WEST MONROE STREET, CHICAGO, IL 60661 USA
DIRECTOR	JOSEPH M. TUCCI	500 WEST MONROE STREET, CHICAGO, IL 60661 USA
DIRECTOR	AYANNA M. HOWARD	500 WEST MONROE STREET, CHICAGO, IL 60661 USA
DIRECTOR	JUDY C. LEWENT	500 WEST MONROE STREET, CHICAGO, IL 60661 USA

5. Describe the purposes and general nature and kind of business in which the corporation engaged in during the year covered by this report:

MANUFACTURING

6. Enter the apportionment percentage from the most recent filed Michigan tax return:

Total Authorized shares:	600500000	Most recent apportionment percentage:	2.1003	For year ending:	2023 <input checked="" type="checkbox"/>
Previous attributable shares:	15038922	Previous period apportionment percentage:	1.7419	For year ending:	2022

This document must be signed by an authorized officer or agent:

Signed this 3rd Day of June, 2025 by:

Signature	Title	Title if "Other" was selected
Kelly Lettmann	Other	POWER OF ATTORNEY

By selecting ACCEPT, I hereby acknowledge that this electronic document is being signed in accordance with the Act. I further certify that to the best of my knowledge the information provided is true, accurate, and in compliance with the Act.

Decline Accept

MICHIGAN DEPARTMENT OF LICENSING AND REGULATORY AFFAIRS
FILING ENDORSEMENT

This is to Certify that the 2025 ANNUAL REPORT

for

MOTOROLA SOLUTIONS, INC.

ID Number: 801008236

received by electronic transmission on June 03, 2025, is hereby endorsed.

Filed on June 03, 2025, by the Administrator.

The document is effective on the date filed, unless a subsequent effective date within 90 days after received date is stated in the document.



In testimony whereof, I have hereunto set my hand and affixed the Seal of the Department, in the City of Lansing, this 3rd day of June, 2025.

Linda Clegg

Linda Clegg, Director

Corporations, Securities & Commercial Licensing Bureau



Scheduled SAM Maintenance
Jan 20, 2026

SAM.gov will undergo planned maintenance on Tuesday, January 27th, 2026 from 8:00 PM to 11:00 PM EST. Users in SAM.gov will be unable to complete Entity Registrations and Exclusions during this window. Thank you for your understanding.



[See All Alerts](#)



[Home](#) [Search](#) [Data Bank](#) [Data Services](#) [Help](#)

Search

All Words

e.g. 1606N020Q02

Filter By

Keyword Search

For more information on how to use our keyword search, visit our [help guide](#)

Simple Search

Search Editor

- Any Words ⓘ
- All Words ⓘ
- Exact Phrase ⓘ

e.g. 123456789, Smith Corp

"Motorola Solutions, Inc." x

Classification

Excluded Individual

Excluded Entity

Entity Name

e.g. ABC Inc ▼

Unique Entity ID

e.g. HTYR9YJHK65L ▼

CAGE / NCAGE

Enter CAGE/NCAGE Code

Federal Organizations

Exclusion Type

Exclusion Program

Location

Dates

Reset 

Entity Information



Entities

Disaster Response Registry

Responsibility / Qualification

Exclusions



No matches found

We couldn't find a match for your search criteria.

Please try another search or go back to previous results.

Go Back



Feedback

Our Website

[About This Site](#)

[Our Community](#)

[Release Notes](#)

[System Alerts](#)

Policies

[Terms of Use](#)

[Privacy Policy](#)

[Restricted Data Use](#)

[Freedom of Information Act](#)

[Accessibility](#)

Our Partners

[Acquisition.gov](#)

[USASpending.gov](#)

[Grants.gov](#)

[More Partners](#)

Customer Service

[Help](#)

[Check Entity Status](#)

[Federal Service Desk](#)

[External Resources](#)

[Contact](#)



⚠ WARNING

This is a U.S. General Services Administration Federal Government computer system that is **"FOR OFFICIAL USE ONLY."** This system is subject to monitoring. Individuals found performing unauthorized activities are subject to disciplinary action including criminal prosecution.

This system contains Controlled Unclassified Information (CUI). All individuals viewing, reproducing or disposing of this information are required to protect it in accordance with 32 CFR Part 2002 and GSA Order CIO 2103.2 CUI Policy.

SAM.gov

An official website of the U.S. General Services Administration

260218



RESOLUTION NO.: _____

PRESENTED: 6-17-2026

ADOPTED: _____

BY THE CITY ADMINISTRATOR:

RESOLUTION TO LAFONTAINE CHEVROLET PLYMOUTH FOR THE PURCHASE OF TWO (2) CHEVROLET CARGO VANS

The City of Flint Water Service Center, Utilities Division, requests a purchase order be issued to LaFontaine Chevrolet Plymouth of Plymouth, for the purchase of two (2) Chevrolet cargo vans. These vans will replace (2) 2008 step vans which have already been turned in for auction. These vans will be utilized by the service section of the water department for the completion of their daily work orders. All old vehicles will be auctioned off in accordance with City of Flint procedures.

This is a qualified purchase under MiDeal State Contract #240000001210. There is adequate funding for said purchases from the listed accounts:

591-540.202-977.500	Vehicle	\$124,566.00
	TOTAL:	\$124,566.00

IT IS RESOLVED, that The Division of Purchases and Supplies, upon City Council’s approval, is hereby authorized to issue a Purchase Order to LaFontaine Chevrolet Plymouth of Plymouth, MI for the purchase of two (2) Chevrolet cargo vans in an amount not to exceed \$124,566.50 for FY26 (07/01/25-06/30/2026).

FOR THE CITY OF FLINT:

APPROVED BY CITY COUNCIL:

Clyde Edwards, City Administrator

APPROVED AS TO FORM:

APPROVED AS TO FINANCE:

JoAnne Gurley
JoAnne Gurley (Jun 3, 2026 23:10:34 EDT)
Joanne Gurley, City Attorney

Phillip Moore
Phillip Moore (Jun 2, 2026 21:46:16 EDT)
Phillip Moore, Chief Financial Officer

APPROVED AS TO PURCHASING:

Lauren Rowley
Lauren Rowley, Purchasing Manager



STAFF REVIEW FORM

Effective: April 1, 2026

(Do not alter or modify this form without written permission from the City Administrator)

TODAY'S DATE: May 1, 2026

BID PROPOSAL #:

AGENDA ITEM TITLE: Cargo Van Purchase

PREPARED BY: Cheri Priest for Howard Hudson, Water Distribution Supervisor

VENDOR NAME: Lafontaine Chevrolet Plymouth, Inc.

Section 1. BACKGROUND/SUMMARY OF PROPOSED ACTION.

Vendor Compliance (This vendor has been properly vetted and the responses are below) :

Federal gov't	(All documentation current, no violations)	<input checked="" type="checkbox"/> YES	<input type="checkbox"/> NO
State gov't	(All documentation current, no violations)	<input checked="" type="checkbox"/> YES	<input type="checkbox"/> NO
City of Flint	(All documentation current, no violations)	<input checked="" type="checkbox"/> YES	<input type="checkbox"/> NO

The requesting authority is validating that this vendor has been in full compliance with all past contract provisions and has not violated the terms of any contract with the City of Flint.

NOTE: Preparer **MUST** include a response to the conditions below:

- Did we do an assessment of first consideration to internal City of Flint staff and resources (explain)?
- Why was this vendor chosen?
- What history does this vendor have with the City of Flint?
- What steps will be taken to do a post-performance of the vendor?

The Water Department request a purchase order be issued to Lafontaine Chevrolet Plymouth for the purchase of (2) 2026 Chevrolet cargo vans. These vehicles will replace (2) 2008 step vans that have been turned into fleet to auction off according to established City of Flint procedures. The cargo vans will be used for the service section of the water department for their daily work orders. The water department has utilized Lafontaine Automotive many times, have had no issues and receive excellent service. Our sales representative is very accommodating to our requests for vehicles. The 2 vans are currently in stock and can be delivered as soon as the request is processed. This purchase is allowed under the MiDeal contract #24000001210.

PROCUREMENT (MUST BE SPECIFIED)

Please specify how this vendor was identified: (Check one)

- Sole Source (Please attach sole source statement to requisition)
- Competitive Bid Process (Please attach bid tabulation/documents to requisition)
- Cooperative Contract (MiDeal, Sourcewell, GSA, or other municipalities)
 *Contract must be attached to your requisition and contract must appear on the vendor's quote for goods/services
- (3) Quotes (please attach all quotes to your requisition)



STAFF REVIEW FORM

Effective: April 1, 2026

(Do not alter or modify this form without written permission from the City Administrator)

Section 2. PREVIOUS ALLOCATIONS (INCLUDE ALL ACCOUNTS USED FOR THIS PURPOSE)/ PROVIDE RESOLUTION OR CONTRACT INFORMATION THAT APPLIES.

Fiscal Year	Account	PO Number	FY PO Amount	FY Expensed	Resolution
2026	591-540.202-977.500	26-9065**	\$323,842.00	\$259,018.60	250381-T
	591-540.202-977.500	26-9391	\$524,431.50	\$307,083.40 to date	260076
2024	591-540.202-977.500	24 6690**	\$315,308.00	\$157,654.00	230411
2023	591-540.202-977.500	23-5902	\$136,080.00	\$136,080.00	230174

** PO is exhausted, remaining balance belongs to sewer**

Section 3. POSSIBLE BENEFIT TO THE CITY OF FLINT (RESIDENTS AND/OR CITY OPERATIONS) INCLUDE PARTNERSHIPS AND COLLABORATIONS.

The residents benefit by having operational vehicles with less down time. The current 2008 step vans are considered obsolete and almost impossible to find parts for. These vehicles are driven almost daily and take a beating and are way past their usefulness. We consider them workshops on wheels, usually everything anyone would need for a job is on the truck. The new cargo vans are smaller, which works well for the service section of the water department. The new vehicles will have more reliability, be more fuel efficient, and will be easier to access and maneuver.

Section 4. FINANCIAL IMPLICATIONS.

IF ARPA related Expenditure:

Has this request been reviewed by E&Y Firm: YES NO IF NO, PLEASE EXPLAIN:

NOTE: Accountant MUST include the following information:

- What is the total amount budgeted for this purpose?
- What percentage is being spent with this vendor?
- What is the justification for spending this amount of money with this vendor?
- What percentage is being spent out of each line item used in this request?
- List all the known budgeted funds from that line item.



STAFF REVIEW FORM

Effective: April 1, 2026

(Do not alter or modify this form without written permission from the City Administrator)

\$1,600,000.00 has been allocated to this fund
 \$124,556.00 is the quoted price for this purchase
 This vendor and vehicles were selected because the vehicles are in stock and on the lot. We have also utilized this vendor in the past and find they provide excellent service. They are also a MiDeal vendor which saves time on the bid process.
 This request represents about 7.78% of the total allocation

To date the following PO's have been issued with this GL#:
 AIS - backhoe loader - \$182,808.00
 Lafontaine - \$259,018.60 - 5 Ford vans (meter room)
 Mtech - \$424,109.86 hydro excavation truck
 Lafontaine - \$307,083.40 - trucks

BUDGETED EXPENDITURE? YES NO IF NO, PLEASE EXPLAIN:

Dept.	Name of Account	Account Number	Grant CODE	Amount
2493	Vehicle	591-540.202-977.000	N/A	\$124,556.00
FY26 GRAND TOTAL				\$124,556.00

WHEN APPLICABLE, IF MORE THAN ONE (1) YEAR, PLEASE ESTIMATE TOTAL AMOUNT FOR EACH BUDGET YEAR: (This will depend on the term of the bid proposal)

BUDGET YEAR 1: _____
 BUDGET YEAR 2: _____
 BUDGET YEAR 3: _____

OTHER IMPLICATIONS (i.e., collective bargaining). _____

PRE-ENCUMBERED? YES NO REQUISITION NO: 26-11452

ACCOUNTING APPROVAL: Cheri Priest Date: 05/07/2026

WILL YOUR DEPARTMENT NEED A CONTRACT? YES NO

Section 5. RESOLUTION DEFENSE TEAM.
 (Place the names of those who can defend this resolution at City Council)



STAFF REVIEW FORM

Effective: April 1, 2026

(Do not alter or modify this form without written permission from the City Administrator)

	NAME	PHONE NUMBER
1	Howard "Dan" Hudson	810-365-7448
2	Entrice "Jiggy" Mitchell	810-691-4345
3	Marquita Blair	810-423-5650
4		

STAFF RECOMMENDATION: (PLEASE SELECT): APPROVED NOT APPROVED

DEPARTMENT HEAD SIGNATURE: [Signature]
Howard "Dan" Hudson (May 7, 2026 11:28:57 EDT)
(Name, Title)

ADMINISTRATION APPROVAL: [Signature]
Clyde Edwards (May 24, 2026 18:46:28 EDT)
(\$20,000 or above spending authorizations)

FLEET APPROVAL: [Signature]
Marquita Blair (May 23, 2026 12:48:01 EDT)

Section 6. VENDOR EVALUATION.

Business Title:	Lafontaine Chevrolet Plymouth	Vendor ID:9471
Review Period:	1-1-26 - 5-1-26	Department: Water
Project Name:	Cargo Vans (2)	Project Type: N/A

Vendor Goals:

To provide vehicles in as timely a manner as possible for the City of Flint at the most cost-effective price.



STAFF REVIEW FORM

Effective: April 1, 2026

(Do not alter or modify this form without written permission from the City Administrator)

	1 = Poor	2 = Fair	3 = Sufficient	4 = Good	5 = Excellent
Job Knowledge:	<input type="checkbox"/>	<input type="checkbox"/>	<input type="checkbox"/>	<input type="checkbox"/>	<input checked="" type="checkbox"/>
Work Quality:	<input type="checkbox"/>	<input type="checkbox"/>	<input type="checkbox"/>	<input type="checkbox"/>	<input checked="" type="checkbox"/>
Timeliness:	<input type="checkbox"/>	<input type="checkbox"/>	<input type="checkbox"/>	<input type="checkbox"/>	<input checked="" type="checkbox"/>
Compliance with Contract:	<input type="checkbox"/>	<input type="checkbox"/>	<input type="checkbox"/>	<input type="checkbox"/>	<input checked="" type="checkbox"/>
Warranty (If Product):	<input type="checkbox"/>	<input type="checkbox"/>	<input type="checkbox"/>	<input type="checkbox"/>	<input checked="" type="checkbox"/>
Responsiveness:	<input type="checkbox"/>	<input type="checkbox"/>	<input type="checkbox"/>	<input type="checkbox"/>	<input checked="" type="checkbox"/>
Cost Effectiveness:	<input type="checkbox"/>	<input type="checkbox"/>	<input type="checkbox"/>	<input type="checkbox"/>	<input checked="" type="checkbox"/>
Dependability:	<input type="checkbox"/>	<input type="checkbox"/>	<input type="checkbox"/>	<input type="checkbox"/>	<input checked="" type="checkbox"/>
Total Performance:	<input type="checkbox"/>	<input type="checkbox"/>	<input type="checkbox"/>	<input type="checkbox"/>	<input checked="" type="checkbox"/>
Overall Rating:	<input type="checkbox"/>	<input type="checkbox"/>	<input type="checkbox"/>	<input type="checkbox"/>	<input checked="" type="checkbox"/>

DEFECTS (IF ANY): IF CHECKED, PLEASE EXPLAIN:

Performance / Other Comments:

This vendor has been extremely responsive to the needs of the Water Service Center, both sewer and water have purchased vehicles from them. Our salesperson goes above and beyond when looking for available trucks and vans. Lafontaine has numerous dealerships located throughout the state and spends a great deal of time trying to find vehicles that meet our expectations and specifications. Our number one requirement, if possible, is that the vehicles are in stock and ready to purchase. They will hold vehicles for the WSC while waiting for purchasing approval. This vendor has shown commitment to providing the City of Flint with dependable transportation solutions. They understand municipal fleet requirements, and we value them for their reliability, responsive service and ability to provide fleet ready vehicles that meet operational demands while staying within our budget. Their ongoing support and professionalism have made them a trusted transportation partner.

REVIEWER'S SIGNATURE: Cheri Priest

Date: 05/23/2026

Forest River, Inc.
 900 County Road 1
 PO BOX 3030
 Elkhart, IN 46515
 USA



Quote

Site/Division # 029
 Telephone 574-295-1022
 Page 1 of 3
 Version S4267265-1
 Date 4/7/2026
 Sales order S4267265
 Original sales id
 PO number
 Your ref. 14' WP
 Payment COD
 Sales ID: Name 1276 : Vincent Hanes
 Retailer name
 Currency USD
 Delivery mode MAN FRT
 Forest River VIN
 Short VIN

DRAFT

Bill to:
 Account: 1006472
 LAFONTAINE CHEVROLET INC
 7120 DEXTER ANN ARBOR RD
 DEXTER, MI 48130
 USA
 Ship to:
 LAFONTAINE CHEVROLET INC
 7120 DEXTER ANN ARBOR RD
 DEXTER, MI 48130
 USA

Method of payment : On account

Item number	Description	Quantity	Unit	Sales price	Discount	Amount
RPAF1466W	ROCKPORT: 14'IL x 96"OW x 78"IH WORKPORT FEATURES: PLATE SIDEWALLS, BULKHEAD SLIDING DOOR ON CAB SIDE W/ 6" SET BACK WALL FOR FULL SEAT TRAVEL, TRUE NOMINAL BODY LENGTH BEHIND SET BACK WALL, ALUM FRONT RADIUS & HIGH IMPACT FRONT RADIUS CORNERS, ALUM VERTICAL CORNERS, 3 1/2" XMEMBERS 24" OC, TUFF-PLY RUBBER FLOOR COVERING OVER 1 1/8" PLYWOOD FLOOR, WHEELWELLS, REAR MUD FLAPS (1) ADJUSTABLE SHELF IN EACH VERT COMP, (6) VERT AND (4) HORIZONTAL ACCESS COMPS W/ COUNTERTOP, ALUM DRIP RAIL ABOVE COMPARTMENTS, ABS DOOR COVERS, SPRING LOADED DOOR CLOSURES, HD ALUM HINGES W/ GREASE ZERKS, FULL ACCESS TO HORIZONTAL COMPS FROM BODY INTERIOR, STEEL REAR STRUCTURE WITH DUAL INTERGRATED LADDERS, (2) LED CARGO LIGHTS W/ 3-WAY LIGHTED CAB SWITCH, 12" STEEL POOCHED REAR STEP BUMPER WITH KICKPLATE, TRANSLUCENT ROOF, ROOF BOWS 12" OC, 3 ROOF LADDER RACKS, 70/ 30 REAR SWING DOORS W/ 47" OPENING, LED CLEARANCE LIGHTS, (2) GRAB HANDLES, UNDERCOATING	1.00	ea			
2026	C26K - 2026 CHEVROLET CG33803 C3500 CUTAWAY CHASSIS, 159" WHEELBASE, DUAL REAR WHEELS, CRUISE, 6.6L GAS ENGINE, 12,300# GVWR, 57 GAL REAR FUEL TANK, INT. & EXT. UPGRADE, FACTORY BACK-UP CAMERA	1.00	ea	\$0.00	\$0.00	\$0.00

Forest River, Inc.
 900 County Road 1
 PO BOX 3030
 Elkhart, IN 46515
 USA



Quote

Site/Division # 029
 Telephone 574-295-1022
 Page 2 of 3
 Version S4267265 1
 Date 4/7/2026
 Sales order S4267265
 Original sales id
 PO number
 Your ref.
 Payment
 Sales ID: Name
 Retailer name
 Currency
 Delivery mode
 Forest River VIN
 Short VIN

Bill to:
 Account: 1006472
 LAFONTAINE CHEVROLET INC
 7120 DEXTER ANN ARBOR RD
 DEXTER, MI 48130
 USA

Ship to:
 LAFONTAINE CHEVROLET INC
 7120 DEXTER ANN ARBOR RD
 DEXTER, MI 48130
 USA

D R A F T

14' WP
 COD
 1276 : Vincent Hanes
 USD
 MAN FRT

Method of payment : On account

Item number	Description	Quantity	Unit	Sales price	Discount	Amount
RP0094	REAR VIEW BACK-UP CAMERA, HIGH DEFINITION, 7" LCD MONITOR & AUDIO - ROCKPORT SUPPLIED IN LIEU OF FACTORY SUPPLIED CAMERA IF EQUIPPED. RETURN FACTORY COMPONENTS IN CAB	1.00	ea	\$495.00	\$0.00	\$495.00
PRODUCTION NOTES: RP0202-1	SHIP BLUETOOTH LOOSE WORKPORT PKG. #3 (CHEV/GMC); ROCKTOP AIR FARING WITH FULL HEIGHT ACCESS DOOR, ELECTRIC MASTER LOCK SYSTEM (INCLUDES REAR DOOR) WITH (02) REMOTE KEY FOBs, INTERIOR ACCESS DOORS, NOTE: ON CHASSIS WITH POWER LOCKS, MASTER LOCK SYSTEM WILL BE INTEGRATED INTO CHASSIS LOCK SYSTEM IF ADAPTABLE, NO FOBs WILL BE PROVIDED). (04) 18" DEEP OSB INTERIOR ADJUSTABLE SHELVES (DRW), (SRW) WILL BE 12"D ALUMINUM CATWALK CENTERED ON LADDER RACKS HORIZONTAL COMPARTMENT DIVIDER BIN PACKAGE ELECTRIC BRAKE CONTROLLER NOTE: AVAILABLE ONLY ON FORD E-SERIES, F-SERIES & GM CUTAWAY CLASS-3 RECEIVER & HARNESS W/ 7-WAY FLAT PLUG 5,000 LB. MAX/500 LB. TONGUE NOTE: PLUG ONLY AVAILABLE ON FORD E-SERIES, F-SERIES, GM CUTAWAY & GM CAB CHASSIS ONLY. NOT AVAILABLE ON LCF. NO HITCHES ON TRANSIT OR PROMASTER	1.00	ea	\$0.00	\$0.00	\$0.00
RP0368	FRONT END ALIGNMENT (ALL CHASSIS UNDER 18,000 LB CURB WEIGHT	1.00	ea			
RP00MS	MATERIAL SURCHARGE	1.00	ea			
RPSP01	INCENTIVE	2.00	ea			

Forest River, Inc.
 900 County Road 1
 PO BOX 3030
 Elkhart, IN 46515
 USA



Quote

Site/Division # 029
 Telephone 574-295-1022
 Page 3 of 3
 Version S4267265-1
 Date 4/7/2026
 Sales order S4267265
 Original sales id
 PO number
 Your ref. 14' WP
 Payment COD
 Sales ID: Name 1276 : Vincent Hanes
 Retailer name
 Currency USD
 Delivery mode MAN FRT
 Forest River VIN
 Short VIN

DRAFT

Bill to:
 Account: 1006472
 LAFONTAINE CHEVROLET INC
 7120 DEXTER ANN ARBOR RD
 DEXTER, MI 48130
 USA
Ship to:
 LAFONTAINE CHEVROLET INC
 7120 DEXTER ANN ARBOR RD
 DEXTER, MI 48130
 USA

Method of payment : On account

Item number	Description	Quantity	Unit	Sales price	Discount	Amount
FREIGHT	FREIGHT		1.00 ea			

THIS QUOTE WILL BECOME AN ORDER WHEN SIGNED AND RETURNED TO ROCKPORT COMMERCIAL VEHICLES. IT IS THE DEALERS RESPONSIBILITY TO VERIFY THE ACCURACY OF THE QUOTE BEFORE SIGNING. OPTIONS SELECTED MAY OVERRIDE STANDARD ITEMS. ROCKPORT IS NOT RESPONSIBLE FOR THE ACCURACY OF CHASSIS PRICING.

NOTE: THIS QUOTE EXPIRES 30 DAYS AFTER DATE OF ENTRY.

SIGNED: _____ DATE: _____

NAME: _____ TITLE: _____

DEALER CODE: _____

CIRCLE ONE: FLEET or RETAIL

ALL FIN/FAN, OPTION AND INCENTIVE CODES: _____

TERMS: ALL ORDERS ARE COD UNLESS PRIOR CREDIT APPROVAL HAS BEEN ARRANGED.

ROCKPORT SALES REP:

LaFontaine Automotive Group

40875 Plymouth Rd

Plymouth, MI 48170

Office 248-714-1071

Cell 517-795-9834

kmartin@lafontaine.com

QUOTATION

Name:	City Of Flint		
Address:	702 W 12th Street		
City:	Flint	State:	MI Zip: 48503
Contact:	Dan Hudson Marquita Blair		
Phone:	810-423-5650		
Email:	mblair@cityofflint.com		

Date:	4/9/2026
Quote:	ROCKPORT

CG33803	2026 Chevrolet Express 3500 159" WB Cutaway	\$43,663.00
GAZ	Summit White Exterior	
93G	Medium Pewter Cloth Interior	
L8T	6.6L Gasoline V8 Engine	
AS5	Custom Cloth Seats with Deluxe Floor Console	
ATG	Remote Keyless Entry	
DHC	Outside Rearview Mirrors	
G80	Auto Locking Rear Differential	
UA1	Heavy Duty Battery	
ZQ2	Power Convenience Package	
ZQ3	Convenience Package	
ZR7	Chrome Appearance Package	
	Rockport 14'x96"x78" Workport Enclosed Utility Body	\$22,700.00
	See attached draft for full build specs	
	State Of Michigan Title Fee	\$15.00
	General Motors Municipal Discount	-\$3,100.00
	Lafontaine Muncipal Discount	-\$1,000.00
	There are 2 of these vehicles that can be ready for you before June 30, 2026	
	Contract 24000001210	
	Note per contract delivery is available @ \$2.00 per one way milcage.	
PRICE IS PER VEHICLE		Total Cost: \$62,278.00

Signed: Kim Martin

Forest River, Inc.
 900 County Road 1
 PO BOX 3030
 Elkhart, IN 46515
 USA



Quote

Site/Division # 029
 Telephone 574-295-1022
 Page 1 of 3
 Version S4267265-1
 Date 4/7/2026
 Sales order S4267265
 Original sales id
 PO number
 Your ref.
 Payment
 Sales ID: Name
 Retail sold name
 Currency
 Delivery mode
 Forest River VIN
 Short VIN

Bill to:
 Account: 1006472
 LAFONTAINE CHEVROLET INC
 7120 DEXTER ANN ARBOR RD
 DEXTER, MI 48130
 USA
 Ship to:
 LAFONTAINE CHEVROLET INC
 7120 DEXTER ANN ARBOR RD
 DEXTER, MI 48130
 USA

D R A F T

14' WP
 COD
 1276 : Vincent Hanes
 USD
 MAN FRT

Method of payment : On account

Item number	Description	Quantity	Unit	Sales price	Discount	Amount
RPAF1466W	ROCKPORT: 14'IL x 96"OW x 78"IH WORKPORT FEATURES: PLATE SIDEWALLS, BULKHEAD SLIDING DOOR ON CAB SIDE W/ 6" SET BACK WALL FOR FULL SEAT TRAVEL, TRUE NOMINAL BODY LENGTH BEHIND SET BACK WALL, ALUM FRONT RADIUS & HIGH IMPACT FRONT RADIUS CORNERS, ALUM VERTICAL CORNERS, 3 1/2" XMEMBERS 24" OC, TUFF-PLY RUBBER FLOOR COVERING OVER 1 1/8" PLYWOOD FLOOR, WHEELWELLS, REAR MUD FLAPS (1) ADJUSTABLE SHELF IN EACH VERT COMP, (6) VERT AND (4) HORIZONTAL ACCESS COMPS W/ COUNTERTOP, ALUM DRIP RAIL ABOVE COMPARTMENTS, ABS DOOR COVERS, SPRING LOADED DOOR CLOSURES, HD ALUM HINGES W/ GREASE ZERKS, FULL ACCESS TO HORIZONTAL COMPS FROM BODY INTERIOR, STEEL REAR STRUCTURE WITH DUAL INTERGRATED LADDERS, (2) LED CARGO LIGHTS W/ 3-WAY LIGHTED CAB SWITCH, 12" STEEL POOCHED REAR STEP BUMPER WITH KICKPLATE, TRANSLUCENT ROOF, ROOF BOWS 12" OC, 3 ROOF LADDER RACKS, 70/ 30 REAR SWING DOORS W/ 47" OPENING, LED CLEARANCE LIGHTS, (2) GRAB HANDLES, UNDERCOATING	1.00	ea			
2026	C26K - 2026 CHEVROLET CG33803 C3500 CUTAWAY CHASSIS, 159" WHEELBASE, DUAL REAR WHEELS, CRUISE, 6.6L GAS ENGINE, 12,300# GVWR, 57 GAL REAR FUEL TANK, INT. & EXT. UPGRADE, FACTORY BACK-UP CAMERA	1.00	ea	\$0.00	\$0.00	\$0.00

Forest River, Inc.
 900 County Road 1
 PO BOX 3030
 Elkhart, IN 46515
 USA



Quote

Site/Division # 029
 Telephone 574-295-1022
 Page 2 of 3
 Version S4267265-1
 Date 4/7/2026
 Sales order S4267265
 Original sales id
 PO number
 Your ref.
 Payment
 Sales ID Name
 Retailer name
 Currency
 Delivery mode
 Forest River VIN
 Short VIN

Bill to:
 Account: 1006472
 LAFONTAINE CHEVROLET INC
 7120 DEXTER ANN ARBOR RD
 DEXTER, MI 48130
 USA

Ship to:
 LAFONTAINE CHEVROLET INC
 7120 DEXTER ANN ARBOR RD
 DEXTER, MI 48130
 USA

DRAFT

14' WP
 COD
 1276 : Vincent Hanes
 USD
 MAN FRT

Method of payment : On account

Item number	Description	Quantity	Unit	Sales price	Discount	Amount
RP0094	REAR VIEW BACK-UP CAMERA, HIGH DEFINITION, 7" LCD MONITOR & AUDIO - ROCKPORT SUPPLIED IN LIEU OF FACTORY SUPPLIED CAMERA IF EQUIPPED. RETURN FACTORY COMPONENTS IN CAB	1.00	ea	\$495.00	\$0.00	\$495.00
PRODUCTION NOTES: RP0202-1	SHIP BLUETOOTH LOOSE WORKPORT PKG. #3 (CHEV/GMC): ROCKTOP AIR FARING WITH FULL HEIGHT ACCESS DOOR, ELECTRIC MASTER LOCK SYSTEM (INCLUDES REAR DOOR) WITH (02) REMOTE KEY FOBs, INTERIOR ACCESS DOORS, NOTE: ON CHASSIS WITH POWER LOCKS, MASTER LOCK SYSTEM WILL BE INTEGRATED INTO CHASSIS LOCK SYSTEM IF ADAPTABLE, NO FOBs WILL BE PROVIDED). (04) 18" DEEP OSB INTERIOR ADJUSTABLE SHELVES (DRW), (SRW) WILL BE 12"D ALUMINUM CATWALK CENTERED ON LADDER RACKS HORIZONTAL COMPARTMENT DIVIDER BIN PACKAGE ELECTRIC BRAKE CONTROLLER NOTE: AVAILABLE ONLY ON FORD E SERIES, F-SERIES & GM CUTAWAY CLASS-3 RECEIVER & HARNESS W/ 7-WAY FLAT PLUG 5,000 LB. MAX/500 LB. TONGUE NOTE: PLUG ONLY AVAILABLE ON FORD E-SERIES, F-SERIES, GM CUTAWAY & GM CAB CHASSIS ONLY. NOT AVAILABLE ON LCF. NO HITCHES ON TRANSIT OR PROMASTER	1.00	ea	\$0.00	\$0.00	\$0.00
RP0368	FRONT END ALIGNMENT (ALL CHASSIS UNDER 18,000 LB CURB WEIGHT	1.00	ea			
RP00MS	MATERIAL SURCHARGE	1.00	ea			
RPSPO1	INCENTIVE	2.00	ea			

Forest River, Inc.
 900 County Road 1
 PO BOX 3030
 Elkhart, IN 46515
 USA



Quote

Site/Division # 029
 Telephone 574-295-1022
 Page 3 of 3
 Version S4267265-1
 Date 4/7/2026
 Sales order S4267265
 Original sales id
 PO number
 Your ref.
 Payment
 Sales ID: Name
 Retailer's name
 Currency
 Delivery mode
 Forest River VIN
 Short VIN

Bill to:
 Account: 1006472
 LAFONTAINE CHEVROLET INC
 7120 DEXTER ANN ARBOR RD
 DEXTER, MI 48130
 USA

Ship to:
 LAFONTAINE CHEVROLET INC
 7120 DEXTER ANN ARBOR RD
 DEXTER, MI 48130
 USA

DRAFT

14' WP
 COD
 1276 : Vincent Hanes
 USD
 MAN FRT

Method of payment : On account

Item number	Description	Quantity	Unit	Sales price	Discount	Amount
FREIGHT	FREIGHT	1.00	ea			

THIS QUOTE WILL BECOME AN ORDER WHEN SIGNED AND RETURNED TO ROCKPORT COMMERCIAL VEHICLES. IT IS THE DEALERS RESPONSIBILITY TO VERIFY THE ACCURACY OF THE QUOTE BEFORE SIGNING. OPTIONS SELECTED MAY OVERRIDE STANDARD ITEMS. ROCKPORT IS NOT RESPONSIBLE FOR THE ACCURACY OF CHASSIS PRICING.

NOTE: THIS QUOTE EXPIRES 30 DAYS AFTER DATE OF ENTRY.

SIGNED: _____ DATE: _____

NAME: _____ TITLE: _____

DEALER CODE: _____

CIRCLE ONE: FLEET or RETAIL

ALL FIN/FAN, OPTION AND INCENTIVE CODES: _____

TERMS: ALL ORDERS ARE COD UNLESS PRIOR CREDIT APPROVAL HAS BEEN ARRANGED.

ROCKPORT SALES REP:



Department of Finance - Treasury

Sheldon Nealey
Mayor

Clyde Edwards
City Administrator

Good Standing Certification
Applicant and/or Business Clearance

All applicants for City of Flint funded programs, including federal programs, must remain current and not in default on any obligations related to taxes, fines, penalties, water service, licenses or other forms of penalties.

APPLICANT NAME: Lafontaine Chevrolet Plymouth, Inc

HOME ADDRESS: _____

DBA: _____

BUSINESS ADDRESS: 40875 Plymouth Rd, Plymouth, MI 48170

Please include addresses of all properties in the name of other current and/or former businesses, parent company subsidiaries and/or divisions. Also, please include all former names used while conducting business with the City

This section to be completed by the Department of Finance - Customer Service Division

Please check the following divisions for the status of current and delinquent obligations owed to the City of Flint. Please circle the appropriate response for each division.

WATER DIV.

PROPERTY TAXES DIV.

INCOME TAX DIV.

ENFORCEMENT

MR

CURRENT
CURRENT
CURRENT
CURRENT
CURRENT

DELINQUENT

DELINQUENT

DELINQUENT

DELINQUENT

DELINQUENT

If delinquencies exist, please indicate the date, type and amount of obligation:

Cheri Priest, 5-4-26
City Staff Person and Date

Karla Rowe, 5-5-26
City of Flint Customer Serv. Representative and Date



Business Search

As of 5/7/2026:

Business Filings are processed through 05/04/2026

Renewals and Restorations (for entities returning to good standing) are processed through 05/06/2026.

To file a document or annual report/statement for an existing entity, search for the entity, select Request Access from the slide-out drawer, complete the questions, refresh the webpage, and select File Subsequent Document or File Annual Report/Statement.

The same process applies to order certificates and copies.

You must be logged in to file documents or order certificates and copies. Click on the Login button in the top right. If you do not have an account, create one. The credentials from the previous system did not transfer to this system.

Business Search Info:

lafontaine chevrolet plymou

Advanced

Results: 1

Name	Filing Date	Status	AR Standing	Entity
	01/09/2023	Active	Good	Dome Profit Corpo

Entity Name	LAFONTAINE CHEVROLET PLYMOUTH, INC.
Identification #	802968486
Jurisdiction	Michigan
Entity Type	Domestic Profit Corporation
Entity Status	Active
AR Standing	Good
Common Shares	400000
AR Due Date	05/15/2027
Initial Filing Date	01/09/2023
Last Report with Officers and Directors	2026
Resident Agent Name	RYAN P. LAFONTAINE
Registered Office Street Address	4000 W. HIGHLAND ROAD, HIGHLAND, MI 48357
Registered Office Mailing Address	4000 W. HIGHLAND ROAD, HIGHLAND, MI 48357
President Name & Address	RYAN LAFONTAINE 4000 W HIGHLAND RD, HIGHLAND, MI 48357
Secretary Name & Address	RYAN LAFONTAINE 4000 W HIGHLAND RD, HIGHLAND, MI 48357
Treasurer Name & Address	RYAN LAFONTAINE 4000 W HIGHLAND RD, HIGHLAND, MI 48357
Directors Names & Addresses	KELLEY LAFONTAINE-HINSPERGER 4000 W HIGHLAND RD, HIGHLAND, MI 48357 MICHAEL T LAFONTAINE 4000 W HIGHLAND RD, HIGHLAND, MI 48357 RYAN LAFONTAINE 4000 W HIGHLAND RD, HIGHLAND, MI 48357



View History & Filings



Assumed Names

Known Issues with the Manage Contract Awards page in SAM.gov.
Show Details
May 6, 2026



See All Alerts

Contract Award Data Processing Delay Show Details
May 4, 2026



Home Search Data Bank Data Services Help

Search All Words e.g. 1606N020Q02

Advanced Search Saved Searches

Filter By

Keyword Search

For more information on how to use our keyword search, visit our help guide

Simple Search

Search Editor

Any Words *i*

All Words *i*

Exact Phrase *i*

e.g. 1606N020Q02

"lafontaine chevrolet plymouth" *x*

Federal Organizations

Enter Code or Name *v* *...*

Status

Active

Inactive

No matches found

Your search did not return any results for active records.

Would you like to include inactive records in your search results?

[Search Inactive](#)[Go Back](#)

Signature:



Clyde Edwards (Jun 8, 2026 07:53:01 EDT)

Email: cedwards@cityofflint.com

Our Website

[About This Site](#)[Our Community](#)[Release Notes](#)[System Alerts](#)

Policies

[Terms of Use](#)[Privacy Policy](#)[Restricted Data Use](#)[Freedom of Information Act](#)[Accessibility](#)

Our Partners

[Acquisition.gov](#)[USASpending.gov](#)[Grants.gov](#)[More Partners](#)

Customer Service

[Help](#)[Check Entity Status](#)[Federal Service Desk](#)[External Resources](#)[Contact](#)

WARNING

This is a U.S. General Services Administration Federal Government computer system that is **"FOR OFFICIAL USE ONLY."** This system is subject to monitoring. Individuals found performing unauthorized activities are subject to disciplinary action including criminal prosecution.

This system contains Controlled Unclassified Information (CUI). All individuals viewing, reproducing or disposing of this information are required to protect it in accordance with 32 CFR Part 2002 and GSA Order CIO 2103.2 CUI Policy.

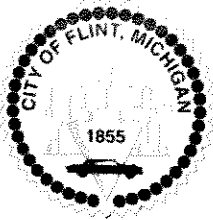

260219

RESOLUTION NO.: _____

PRESENTED: 6-17-2026

ADOPTED: _____

BY THE CITY
ADMINISTRATOR:

RESOLUTION FOR SUPPORT OF THE FY2026 (3X) BRIDGE APPLICATIONS FOR HAMILTON AVENUE OVER FLINT RIVER, STEWART AVENUE OVER C&O RR, AND BEACH STREET OVER THREAD CREEK

WHEREAS, The City of Flint Department of Public Works, Transportation Division, is seeking funding through the State of Michigan Local Bridge Program Call for Applications for Funding Year 2029, and the City of Flint Transportation Division has prepared applications for the Hamilton Avenue over Flint River Bridge (2835), Stewart Avenue over C&O RR Bridge (2837), and Beach Street over Thread Creek (2857) Bridge projects. The Local Bridge Program requires a minimum local match of 5%, and the City of Flint Transportation Division is requesting authorization to commit the required local match for these applications. The total estimated bridge and approach construction cost for the three bridge projects is \$2,722,000.00, with an estimated local match amount of \$136,100.00.

WHEREAS, That the Flint City Council supports the submission of Local Bridge Program applications for Funding Year 2029 for the Hamilton Avenue over Flint River Bridge, Stewart Avenue over C&O RR Bridge, and Beach Street over Thread Creek Bridge projects.

Funding is to come from the following account(s):

Account Number	Account Name/ Grant Code	Amount
202-450.202-801.000	PROFESSIONAL SERVICES	\$ 72,250
202-450.202-801.000	PROFESSIONAL SERVICES	\$ 30,100
202-450.202-801.000	PROFESSIONAL SERVICES	\$ 33,750
	FY2025 TOTAL	\$ 136,100

IT IS RESOLVED, That the appropriate City officials are authorized to execute and submit all documents necessary for the Local Bridge Program applications and to identify the required local match, subject to final award, approval, and budget availability.

APPROVED AS TO FORM:



JoAnne Gurley, City Attorney

APPROVED AS TO FINANCE:



Phillip Moore, Chief Financial Officer

FOR THE CITY OF FLINT:



Clyde Edwards, City Administrator

APPROVED BY CITY COUNCIL:

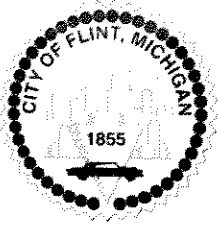

**APPROVED AS TO
PURCHASING:**

Lauren Rowley

Lauren Rowley, Purchasing Manager

RESOLUTION NO.: _____

PRESENTED: _____

ADOPTED: _____



STAFF REVIEW FORM

Effective: April 1, 2026

(Do not alter or modify this form without written permission from the City Administrator)

TODAY'S DATE: May 29, 2026

BID PROPOSAL #: _____

AGENDA ITEM TITLE: Resolution of support for bridge applications

PREPARED BY: Kathryn Neumann

VENDOR NAME: State of Michigan

Section 1. BACKGROUND/SUMMARY OF PROPOSED ACTION..

Vendor Compliance (This vendor has been properly vetted and the responses are below) :

Federal gov't	(All documentation current, no violations)	<input type="checkbox"/> YES	<input type="checkbox"/> NO
State gov't	(All documentation current, no violations)	<input type="checkbox"/> YES	<input type="checkbox"/> NO
City of Flint	(All documentation current, no violations)	<input type="checkbox"/> YES	<input type="checkbox"/> NO

The requesting authority is validating that this vendor has been in full compliance with all past contract provisions and has not violated the terms of any contract with the City of Flint.

NOTE: Preparer **MUST** include a response to the conditions below:

- Did we do an assessment of first consideration to internal City of Flint staff and resources (explain)?
- Why was this vendor chosen?
- What history does this vendor have with the City of Flint?
- What steps will be taken to do a post-performance of the vendor?

Once a year the Michigan Department of Transportation allocates project funds to local governments to repair or rehabilitate bridges that are in pressing need of repair or new design. The City of Flint is submitting applications to replace and rehabilitate three bridges for the FY2029 year: Hamilton Avenue over Flint River Bridge; Stewart Avenue over C & O RR Bridge and Beach Street over Thread Creek Bridge that meets the criteria.

PROCUREMENT (MUST BE SPECIFIED)

Please specify how this vendor was identified: (Check one)

- Sole Source (Please attach sole source statement to requisition)
- Competitive Bid Process (Please attach bid tabulation/documents to requisition)
- Cooperative Contract (MIDeal, Sourcwell, GSA, or other municipality)
 - *Contract must be attached to your requisition and contract must appear on the vendor's quote for goods/services
- (3) Quotes (please attach all quotes to your requisition)

Section 2. PREVIOUS ALLOCATIONS (INCLUDE ALL ACCOUNTS USED FOR THIS PURPOSE)/ PROVIDE RESOLUTION OR CONTRACT INFORMATION THAT APPLIES..



STAFF REVIEW FORM

Effective: April 1, 2026

(Do not alter or modify this form without written permission from the City Administrator)

Fiscal Year	Account	PO Number	FY PO Amount	FY Expensed	Resolution

**Section 3. POSSIBLE BENEFIT TO THE CITY OF FLINT (RESIDENTS AND/OR CITY OPERATIONS)
INCLUDE PARTNERSHIPS AND COLLABORATIONS..**

Preventative maintenance on bridges will make the bridges last longer before they must be replaced. It is cheaper to perform preventive maintenance than replacing a bridge sooner than anticipated because of neglect. Preventative maintenance will also make existing bridges safer because they will identify and fix small problems before they grow to become big problems.

Section 4. FINANCIAL IMPLICATIONS..

IF ARPA related Expenditure:

Has this request been reviewed by E&Y Firm: YES NO IF NO, PLEASE EXPLAIN:

NOTE: Accountant MUST include the following information:

- What is the total amount budgeted for this purpose?
- What percentage is being spent with this vendor?
- What is the justification for spending this amount of money with this vendor?
- What percentage is being spent out of each line item used in this request?
- List all the known budgeted funds from that line item.

BUDGETED EXPENDITURE? YES NO IF NO, PLEASE EXPLAIN:



STAFF REVIEW FORM

Effective: April 1, 2026

(Do not alter or modify this form without written permission from the City Administrator)

Dept.	Name of Account	Account Number	Grant CODE	Amount
FY26 GRAND TOTAL				

WHEN APPLICABLE, IF MORE THAN ONE (1) YEAR, PLEASE ESTIMATE TOTAL AMOUNT FOR EACH BUDGET YEAR: (This will depend on the term of the bid proposal)

BUDGET YEAR 1: _____

BUDGET YEAR 2: _____

BUDGET YEAR 3: _____

OTHER IMPLICATIONS (i.e., collective bargaining).. _____

PRE-ENCUMBERED? YES NO REQUISITION NO: _____

ACCOUNTING APPROVAL: Jo Janiski (May 29, 2026 14:04:59 EDT) Date: _____

WILL YOUR DEPARTMENT NEED A CONTRACT? YES NO

Section 5. RESOLUTION DEFENSE TEAM..

(Place the names of those who can defend this resolution at City Council)

	NAME	PHONE NUMBER
1	Danny Schiller	810 691-4788
2	Jo Janiski	810 766-7266
3		
4		

STAFF RECOMMENDATION: (PLEASE SELECT): APPROVED NOT APPROVED

DEPARTMENT HEAD SIGNATURE: Dan Schiller (Dan Schiller (May 29, 2026 15:20:07 EDT))



STAFF REVIEW FORM

Effective: April 1, 2026

(Do not alter or modify this form without written permission from the City Administrator)

(Lee Osborne, Facilities Maintenance Operations Manager, Danny Schiller, Provisional Director of Transportation)

ADMINISTRATION APPROVAL:

(\$20,000 or above spending authorizations)

Clyde Edwards / A0662 (Jun 3, 2026 11:33:03 EDT)

Section 6. VENDOR EVALUATION..

Business Title:

Vendor ID:

Review Period:

Department:

Project Name:

Project Type:

Vendor Goals:

1 = Poor 2 = Fair 3 = Sufficient 4 = Good 5 = Excellent

	1 = Poor	2 = Fair	3 = Sufficient	4 = Good	5 = Excellent
Job Knowledge:	<input type="checkbox"/>	<input type="checkbox"/>	<input type="checkbox"/>	<input checked="" type="checkbox"/>	<input type="checkbox"/>
Work Quality:	<input type="checkbox"/>	<input type="checkbox"/>	<input type="checkbox"/>	<input checked="" type="checkbox"/>	<input type="checkbox"/>
Timeliness:	<input type="checkbox"/>	<input type="checkbox"/>	<input type="checkbox"/>	<input checked="" type="checkbox"/>	<input type="checkbox"/>
Compliance with Contract:	<input type="checkbox"/>	<input type="checkbox"/>	<input type="checkbox"/>	<input checked="" type="checkbox"/>	<input type="checkbox"/>
Warranty (If Product):	<input type="checkbox"/>	<input type="checkbox"/>	<input type="checkbox"/>	<input checked="" type="checkbox"/>	<input type="checkbox"/>
Responsiveness:	<input checked="" type="checkbox"/>	<input type="checkbox"/>	<input type="checkbox"/>	<input checked="" type="checkbox"/>	<input type="checkbox"/>
Cost Effectiveness:	<input type="checkbox"/>	<input type="checkbox"/>	<input type="checkbox"/>	<input checked="" type="checkbox"/>	<input type="checkbox"/>
Dependability:	<input type="checkbox"/>	<input type="checkbox"/>	<input type="checkbox"/>	<input checked="" type="checkbox"/>	<input type="checkbox"/>
Total Performance:	<input type="checkbox"/>	<input type="checkbox"/>	<input type="checkbox"/>	<input checked="" type="checkbox"/>	<input type="checkbox"/>
Overall Rating:	<input type="checkbox"/>	<input type="checkbox"/>	<input type="checkbox"/>	<input checked="" type="checkbox"/>	<input type="checkbox"/>



STAFF REVIEW FORM

Effective: April 1, 2026

(Do not alter or modify this form without written permission from the City Administrator)

DEFECTS (IF ANY): IF CHECKED, PLEASE EXPLAIN:

None

Performance / Other Comments:

REVIEWER'S SIGNATURE: _____

Date: _____

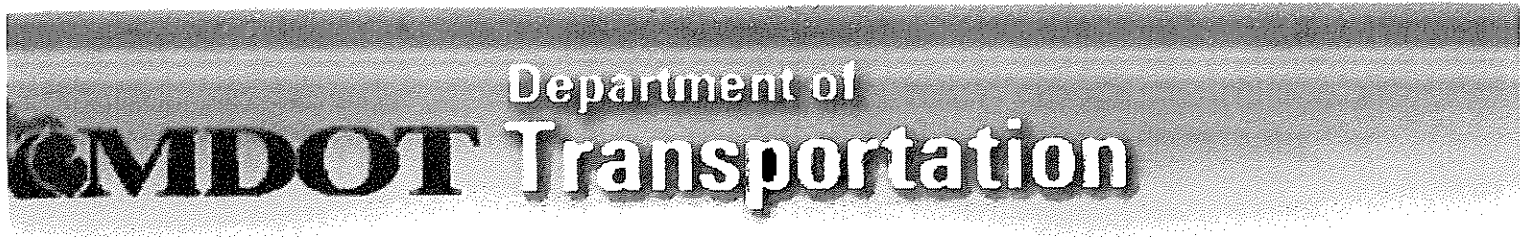

LOCAL BRIDGE PROGRAM CALL FOR APPLICATIONS FUNDING YEAR 2029

NOTE TO USERS: Please be sure that all structure information is correct on your SI&A form in MiBridge before submitting your application. Applications received after April 1st, 2026 will not be accepted. For assistance, please call Keith Cooper at (517) 331-1395 or Rita Levine at (517) 335-4528.

Instructions: (This form requires Adobe Acrobat Standard or Professional and is not enabled for use in the free Adobe Reader. If you only have access to Adobe Reader, please submit paper documents.)

1. Complete the required application information below.
2. Click on ADD APPLICATION DOCS button to add your signed resolution, cost estimate, map showing structure location and detour route, narrative description of project, bridge inspection documents and photos of the structure.
3. When you have finished, click on SAVE AS to keep a copy for each structure you are submitting.
4. Click on SUBMIT to email your application to MDOT-DesignLAP-Bridge@michigan.gov.

*** Multiple structure applications need to be applied for as individual structures and choose "Multiple PM" for "Type of Work".**

APPLICATION INFORMATION (REQUIRED)

Agency Name: City of Flint

Structure Number: 2837 County: Genesee Region: Bay Region

Facility Carried: Stewart Avenue

Feature Intersected: C&O RR

Cost Estimate (Bridge and Approach construction cost): \$675,000

Type of Work: PM Local Match (Minimum 5%): 5

(This form requires Adobe Acrobat Standard or Professional and is not enabled for use in the free Adobe Reader. If you only have access to Adobe Reader, please submit paper documents.)

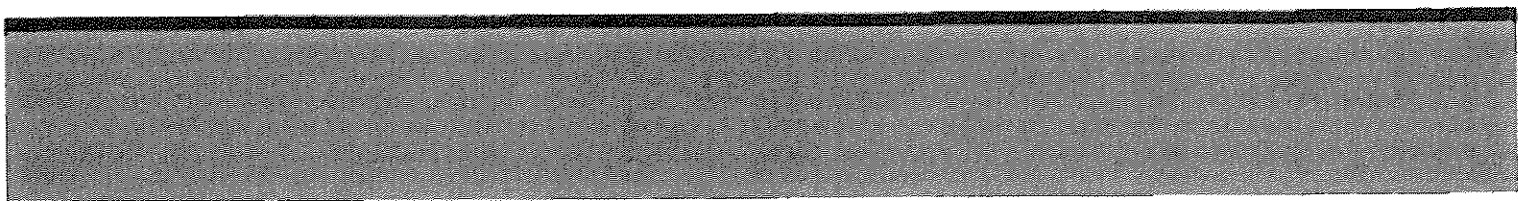

Department of MDOT Transportation

LOCAL BRIDGE PROGRAM CALL FOR APPLICATIONS FUNDING YEAR 2029

NOTE TO USERS: Please be sure that all structure information is correct on your SI&A form in MiBridge before submitting your application. Applications received after April 1st, 2026 will not be accepted. For assistance, please call Keith Cooper at (517) 331-1395 or Rita Levine at (517) 335-4528.

Instructions: (This form requires Adobe Acrobat Standard or Professional and is not enabled for use in the free Adobe Reader. If you only have access to Adobe Reader, please submit paper documents.)

1. Complete the required application information below.
2. Click on ADD APPLICATION DOCS button to add your signed resolution, cost estimate, map showing structure location and detour route, narrative description of project, bridge inspection documents and photos of the structure.
3. When you have finished, click on SAVE AS to keep a copy for each structure you are submitting.
4. Click on SUBMIT to email your application to MDOT-DesignLAP-Bridge@michigan.gov.

*** Multiple structure applications need to be applied for as individual structures and choose "Multiple PM" for "Type of Work".**

APPLICATION INFORMATION (REQUIRED)

Agency Name: City of Flint

Structure Number: 2857 County: Genesee Region: Bay Region

Facility Carried: Beach Street

Feature Intersected: Thread Creek

Cost Estimate (Bridge and Approach construction cost): \$1,445,000

Type of Work: Rehab Local Match (Minimum 5%): 5

(This form requires Adobe Acrobat Standard or Professional and is not enabled for use in the free Adobe Reader. If you only have access to Adobe Reader, please submit paper documents.)



LOCAL BRIDGE PROGRAM CALL FOR APPLICATIONS FUNDING YEAR 2029

NOTE TO USERS: Please be sure that all structure information is correct on your SI&A form in MiBridge before submitting your application. Applications received after April 1st, 2026 will not be accepted. For assistance, please call Keith Cooper at (517) 331-1395 or Rita Levine at (517) 335-4528.

Instructions: (This form requires Adobe Acrobat Standard or Professional and is not enabled for use in the free Adobe Reader. If you only have access to Adobe Reader, please submit paper documents.)

1. Complete the required application information below.
2. Click on ADD APPLICATION DOCS button to add your signed resolution, cost estimate, map showing structure location and detour route, narrative description of project, bridge inspection documents and photos of the structure.
3. When you have finished, click on SAVE AS to keep a copy for each structure you are submitting.
4. Click on SUBMIT to email your application to MDOT-DesignLAP-Bridge@michigan.gov.

*** Multiple structure applications need to be applied for as individual structures and choose "Multiple PM" for "Type of Work".**

APPLICATION INFORMATION (REQUIRED)

Agency Name: City of Flint

Structure Number: 2835 County: Genesee Region: Bay Region

Facility Carried: Hamilton Avenue

Feature Intersected: Flint River

Cost Estimate (Bridge and Approach construction cost): \$602,000

Type of Work: PM Local Match (Minimum 5%): 5

(This form requires Adobe Acrobat Standard or Professional and is not enabled for use in the free Adobe Reader. If you only have access to Adobe Reader, please submit paper documents.)

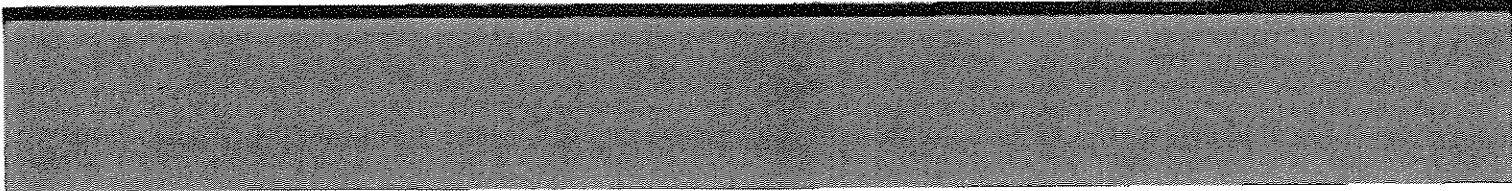

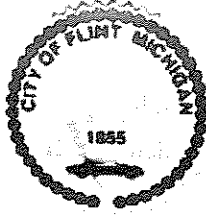

260220

RESOLUTION NO.:

PRESENTED: 6-17-2026

ADOPTED:

RESOLUTION TO POWER INITIATIVE FOR FLINT RECAST PROGRAM IMPLEMENTATION USING CARRY-OVER FUNDS

BY THE CITY ADMINISTRATOR:

WHEREAS, in July 2021, the City of Flint was awarded grant number: 1 H79 SM084918-01, for \$5,000,000.00, over a five-year period. The funding is allocated for the Flint Resiliency in Communities After Stress and Trauma (ReCAST) (Performance period September 30, 2021 – September 29, 2026). The primary strategy of Flint ReCAST is to assist high-risk youth and families in the City of Flint, impacted by the Flint Water Emergency, by promoting resilience and equity through implementation of evidence-based programming as well as linkages to trauma-informed behavioral health services.

WHEREAS, This year Recast is seeking to spend its carried over funds with an organization that can help reach the final goals of recast which include funding for the smaller applicant organizations, youth event coordination, and job training and orientation (see attached proposal). Power Initiative was chosen because of their past performance and their connection to the Recast processes. Their work is grounded in trust, collaboration, and respect and values that allow them to deliver customized, innovative solutions that truly reflect the unique goals of each organization.

WHEREAS, the Power Initiative will be awarded \$140,000.00 from 2025 ReCast Grant. The Power Initiative started in 2020 in Flint, Michigan, with a clear purpose: to leverage the resources and opportunities around us by fostering true community and redefining what community progress looks like. We saw opportunities demanding fresh ideas and real solutions, so we stepped in not just to meet the present but to help shape the future. In the past 2 years Power Initiative has worked with Greater Flint health coalition and the City of Flint as part of the Recast grant serving as the coordinator for mini grants program scoring and selection process, providing grant writing training and funding for the recipients that did not receive mini grants to improve their application for the next year RFP process. For this carryover funds Power Initiative will be performing these three services:

Collaborative Project

Youth Engagement -Community Sponsorships

Youth Engagement-Summer Job Program

Account Number	Grant Code Account Name	Amount
296-649.700-801.000	FHHS21RECAST Professional Services	\$140,000.00

THEREFORE, IT IS RESOLVED that the appropriate City officials, upon the City Council approval, are hereby authorized to do all things necessary, including executing any necessary agreements, to appropriate funding from the funding account 296-649.700-801.000. to Power Initiative in the amount of

\$140,000.00.

Approved as to Form:

JoAnne Gurley (Jun 10, 2026 16:33:51 EDT)

Joanne Gurley, Chief Legal Officer

Approved as to Finance:

Phillip Moore (Jun 11, 2026 09:54:04 EDT)

Phillip Moore, Chief Financial Officer

For the City of Flint:

Clyde Edwards / A0675 (Jun 11, 2026 10:13:11 EDT)

Clyde D. Edwards, City Administrator

Approved by Council:

Legal Department Contract Checklist

ENTITY FULL NAME: The Power Initiative

ADDRESS: 3328 Walton Avenue Flint, Michigan 48504

CONTACT NAME/EMAIL FOR NOTICES: Ashnee Dunning, info@thepowerinitiative.org

CONTRACT PRICE: \$140,000.00

SCOPE OF WORK (ATTACH IF NEEDED):

CHECKLIST FOR DOCUMENTS (STANDINGS MUST BE WITHIN 90 DAYS):

- CERTIFICATE OF INSURANCE (Showing Flint as Additional Insured, Not Expired)
- LARA STANDING
- CITY OF FLINT STANDING
- SAM.GOV STANDING
- ANY BUDGET DOCUMENT OR OTHER ATTACHMENTS (IF APPLIES)

Email all documents and information in a single email to gsteffens@cityofflint.com.
After Legal review and approval, you will receive a digital copy approved by JoAnne Gurley. Thank you.

Scope of work

This pathway builds on last year's Summer Job Program by supporting youth hiring, orientation, and host site coordination. The Power Initiative will manage the application process, support partner site alignment, and coordinate training and orientation activities to help youth and host sites begin the program with clarity. Funds will support a youth hiring event, a youth orientation event, technical assistance, and partner coordination. The goal is to connect youth talent to employment opportunities,

File and/or folders of the device: SAM.gov\Power Initiative LLC



Requests Notifications Workspace Sign Out

Home Search Data Bank Data Services Help

Entity

THE POWER INITIATIVE, LLC • D Assigned

The entity record has been validated as unique and existing, but is not registered in SAM.gov.

Unique Entity ID	Physical Address	Version
08124847WAL17	1238 WALTON AVE FLINT, MI 48999-4238, USA	Current Record



Department of Finance - Treasury

Sheldon Nooley
Mayor

Clyde Edwards
City Administrator

Good Standing Certification

Applicant and/or Business Clearance

All applicants for City of Flint funded programs, including federal programs, must remain current and not in default on any obligations related to taxes, fines, penalties, water service, licenses or other forms of penalties.

APPLICANT NAME: The Power Initiative LLC
HOME ADDRESS: 3328 Walton Flint Michigan 48504
DBA: The Power Initiative LLC
BUSINESS ADDRESS: 3328 Walton Ave. Flint, Michigan 48504

TAX ID: _____
Please include addresses of all properties in the name of other current and/or former businesses, parent company, subsidiaries and/or divisions. Also, please include all former names used while conducting business with the City.

This section to be completed by the Department of Finance - Customer Service Division

Please check the following divisions for the status of current and delinquent obligations owed to the City of Flint. Please circle the appropriate response for each division.

WATER DIV.	CURRENT	DELINQUENT	<i>No water account located</i>
PROPERTY TAXES DIV.	CURRENT	DELINQUENT	<i>No property located</i>
INCOME TAX DIV.	CURRENT	DELINQUENT	<i>No record of city income</i>
ENFORCEMENT	CURRENT	DELINQUENT	<i>tax</i>
MR	CURRENT	DELINQUENT	<i>No mr located</i>

If delinquencies exist, please indicate the date, type and amount of obligation:

Michelle Scott 5/21/2026
City Staff Person and Date

[Signature] 6-5-2026
City of Flint Customer Serv Representative and Date

1101 S. Seginaw St., FLINT MICHIGAN 48502 (810) 766-7436

City of Flint
Contract Development Packet
Resiliency in Communities After Stress and Trauma (ReCAST) Project

Project Name: Collaborative Youth Engagement Project

Name of Agency: The Power Initiative

Address: 3328 Walton Avenue Flint, MI 48504

Contact Person Ashnee Dunning Phone: (810)874-0353

Email: info@freedomsschoolcollab.org

UEI#: G81STK8UWML8 EIN#: 85-1416560

Total ReCAST Allocation Amount: \$140,000.00

Please use this area for your detailed scope of services.

What services or activities will ReCAST funds pay for?

Youth Event Coordination, Youth Professional Development & Management
Community Award Distribution
Summer Job Program Training & Orientation Events; Youth Program Host Site Technical Assistance & Support

What unit of service will be assisted by your programs/activities (households, persons, etc?), and what is the estimated number of units of service will be assisted?

125 Persons assisted
6 Organizations Assisted

What is the geographic service area of your program/project (census tracts, city-wide)?

Flint city-wide

Any other details pertinent to the project?

Project Budget

Line Item	ReCAST Funded Items	Other Funding Sources	Total Project Costs
<i>Personnel and Operational Costs (capped at 10% of allocation)</i>			
Salaries/Wages/Fringes	\$4,086.00		\$4,086.00
Office Supplies	\$10,000.00		\$10,000.00
Mileage Reimbursement			\$0.00
Insurance & Bonding			\$0.00
Building Rent			\$0.00
Utilities			\$0.00
			\$0.00
			\$0.00
			\$0.00
			\$0.00
Total Operational Costs	\$14,086.00	\$0.00	\$14,086.00
<i>Program Delivery Costs (costs of implementing your program)</i>			
Professional Services/Contracts	\$63,000.00		\$63,000.00
Salaries/Wages/Fringes	\$52,914.00		\$52,914.00
Program Supplies	\$10,000.00		\$10,000.00
Program Equipment (items over \$5,000)			\$0.00
Equipment Repairs/Maintenance			\$0.00
Vehicle Repairs/Maintenance			\$0.00
			\$0.00
			\$0.00
			\$0.00
Total Program Delivery Costs:	\$125,914.00	\$0.00	\$125,914.00
Program Totals	\$140,000.00	\$0.00	\$140,000.00

ACORD

CERTIFICATE OF LIABILITY INSURANCE

DATE (MM/DD/YYYY) 06/08/2026

THIS CERTIFICATE IS ISSUED AS A MATTER OF INFORMATION ONLY AND CONFERS NO RIGHTS UPON THE CERTIFICATE HOLDER. THIS CERTIFICATE DOES NOT AFFIRMATIVELY OR NEGATIVELY AMEND, EXTEND OR ALTER THE COVERAGE AFFORDED BY THE POLICIES BELOW. THIS CERTIFICATE OF INSURANCE DOES NOT CONSTITUTE A CONTRACT BETWEEN THE ISSUING INSURER(S), AUTHORIZED REPRESENTATIVE OR PRODUCER, AND THE CERTIFICATE HOLDER.

IMPORTANT: If the certificate holder is an ADDITIONAL INSURED, the policy(ies) must have ADDITIONAL INSURED provisions or be endorsed. If SUBROGATION IS WAIVED, subject to the terms and conditions of the policy, certain policies may require an endorsement. A statement on this certificate does not confer rights to the certificate holder in lieu of such endorsement(s).

PRODUCER: American Heritage Insurance Agency, 3019 E Hill Rd, Grand Blanc, MI 48439. CONTACT NAME: Alison Joersz, PHONE: (810)866-4967, FAX: (810)866-4963, E-MAIL: customerservice@conradinsurancegroup.com. INSURER A: Midvale Indemnity, NAIC #: 27138M.

COVERAGES CERTIFICATE NUMBER: 00006724-260608111825 REVISION NUMBER: 1

THIS IS TO CERTIFY THAT THE POLICIES OF INSURANCE LISTED BELOW HAVE BEEN ISSUED TO THE INSURED NAMED ABOVE FOR THE POLICY PERIOD INDICATED. NOTWITHSTANDING ANY REQUIREMENT, TERM OR CONDITION OF ANY CONTRACT OR OTHER DOCUMENT WITH RESPECT TO WHICH THIS CERTIFICATE MAY BE ISSUED OR MAY PERTAIN, THE INSURANCE AFFORDED BY THE POLICIES DESCRIBED HEREIN IS SUBJECT TO ALL THE TERMS, EXCLUSIONS AND CONDITIONS OF SUCH POLICIES. *LIMITS SHOWN MAY HAVE BEEN REDUCED BY PAID CLAIMS. LIMITS SHOWN ARE INCLUSIVE OF AMOUNTS REQUESTED BY THE CERTIFICATE HOLDER AND MAY NOT REFLECT POLICY LIMIT AMOUNTS IN EXCESS OF THOSE REQUESTED. *Not Applicable in WY

Table with columns: INSR LTR, TYPE OF INSURANCE, ADD'L SUBR, POLICY NUMBER, POLICY EFF, POLICY EXP, LIMITS. Includes Commercial General Liability, Automobile Liability, Umbrella Liability, and Workers Compensation.

DESCRIPTION OF OPERATIONS / LOCATIONS / VEHICLES (ACORD 101, Additional Remarks Schedule, may be attached if more space is required)

CERTIFICATE HOLDER: City of Flint, 1101 S Saginaw St, Flint, MI 48502. CANCELLATION: SHOULD ANY OF THE ABOVE DESCRIBED POLICIES BE CANCELLED BEFORE THE EXPIRATION DATE THEREOF, NOTICE WILL BE DELIVERED IN ACCORDANCE WITH THE POLICY PROVISIONS. AUTHORIZED REPRESENTATIVE: Matthew J Conrad.

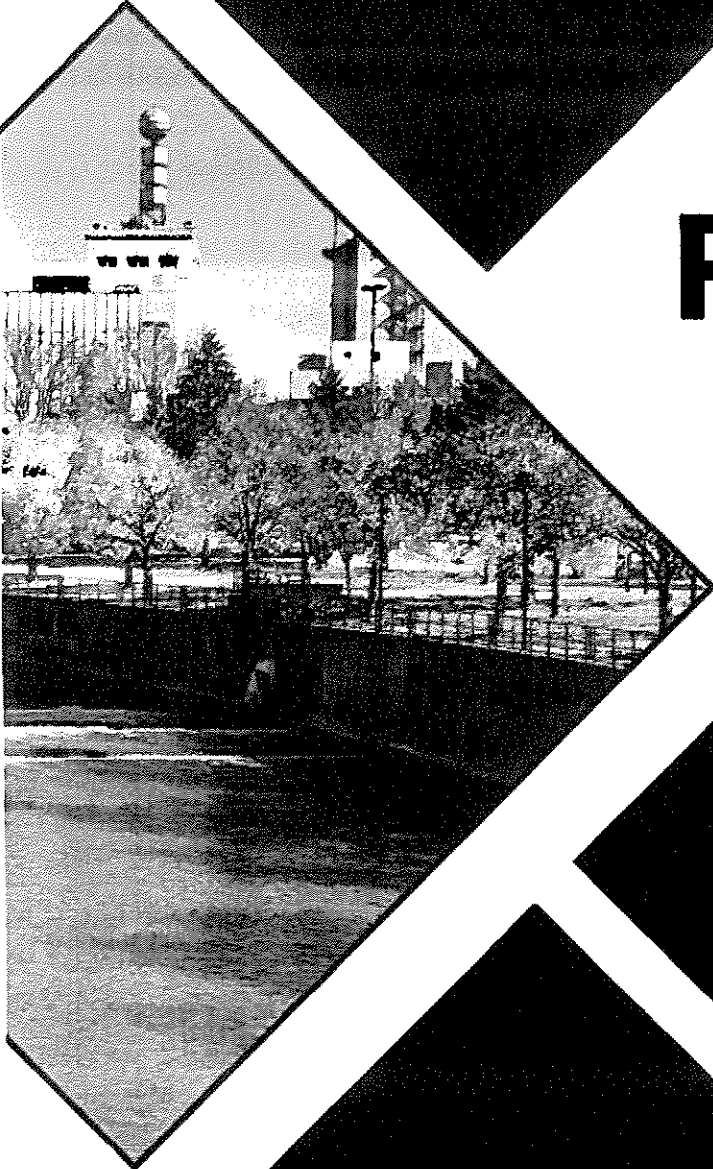

2026 SERVICE PROPOSAL







City of Flint

ReCAST

PROPOSED BY :
The Power Initiative

810-874-0353
www.thepowerinitiative.org
info@thepowerinitiative.org
Flint, MI 48504

Table of Contents

 Introduction	3
 Our Team	4
 What We Do	5
 Recommendation	6
 Project Interpretation	7
 Investment	9
 Let's Connect	10

This proposal is the property of The Power Initiative, LLC and may not be distributed beyond the board and leadership of the City of Flint without written permission. Unauthorized use may be a violation of federal copyright laws and the federal Economic Espionage of 1996.

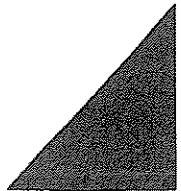

Introduction

The Power Initiative started in 2020 in Flint, Michigan, with a clear purpose: to leverage the resources and opportunities around us by fostering true community and redefining what community progress looks like. We saw opportunities demanding fresh ideas and real solutions, so we stepped in — not just to meet the present but to help shape the future.

We're all about creating real, transformative change. We know the challenges in our systems run deep, but we also believe in unlocking opportunities that already exist within those frameworks. Many organizations have the resources they need—it's just about finding the right strategies to make those resources work harder, smarter, and better. That's where we come in: to close the gaps, maximize potential, and create solutions that are both sustainable and centered on people.

At our core, we believe people are powerful. When equipped with the right tools and support, they can tackle even the toughest challenges. Our work is grounded in trust, collaboration, and respect —values that allow us to deliver customized, innovative solutions that truly reflect the unique goals of each organization we partner with.

Here's How We Do It:

- We use data to tell a story. From start to finish, we analyze what's working, what's not, and how to make it better.
- We bring structure and clarity. By streamlining workflows and automating processes, we transform data into insights that drive real action.
- We meet you where you are. Our approach is flexible and collaborative, designed to adapt to your needs at every step.

Everything we do is guided by a commitment to strategy, sustainability, and inclusion. Our goal is to tackle systemic challenges head-on while delivering results that truly make an impact.

Our Flint Roots

This work hits close to home for us. As proud members of the Flint community, we've seen firsthand what access to resources and opportunities can do. That experience fuels our passion for creating systems that bring about meaningful, lasting change. Whether it's encouraging individuals or strengthening entire organizations, we're here to help build a brighter, more equitable future for the place we call home.

When you work with The Power Initiative, you're not just hiring an agency—you're gaining a partner who's deeply committed to your success. Together, we can create something impactful, meaningful, and unforgettable.

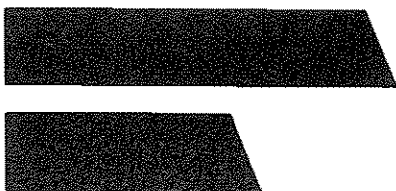

Scan to access
proposal materials
— or visit
bit.ly/cofxpi25

Meet Your Project Team

Ja'Quita Kelley, MBA

Strategic Thought Partner



A proud alumna of Spelman College with a Bachelor's in Political Science, Kayla is a dedicated community advocate passionate about amplifying youth voices and advancing public health. With over seven years of experience working with community-based organizations in the Greater Flint area—including the Flint Public Health Youth Academy, Young, Gifted, and Green, and the Flint Freedom Schools Collaborative—Kayla brings a wealth of knowledge and expertise. As the team's connector, she excels at guiding projects through every stage, offering sharp insights, making impactful contributions, and skillfully presenting ideas with clarity to all collaborators.



Ashnee Dunning, BBA

Chief Executive Officer

A strategic visionary dedicated to fostering collaboration and impactful partnerships, Ashnee holds a Bachelor of Business Administration from Western Michigan University. As the Executive Director of the Flint Freedom Schools Collaborative, she focuses on advancing educational equity, building sustainable community programs, and strengthening organizational leadership. Serving as the team's compass, Ashnee offers forward-thinking insights and innovative strategies to guide our team toward intentional and measurable outcomes.



What Do We Do?

Our company models are rooted in the belief that true transformation begins with people—helping them refine their superpowers, equipping them, and fostering opportunities that are both equitable and enduring. We prioritize inclusive, individualized solutions informed by meaningful community engagement. These steps ensure that our priorities reflect the voices and interests of those we serve.

Since our inception, we've been all about bold moves and smarter strategies, designed to tackle today's complexities while keeping the big picture in focus. We dig deep, think differently, and lean into the messiness of real change because we know that's where the magic happens. The Power Initiative is committed to delivering results that aren't just measurable—they're meaningful, sustainable, and built to leave your company positioned for long-term impact.

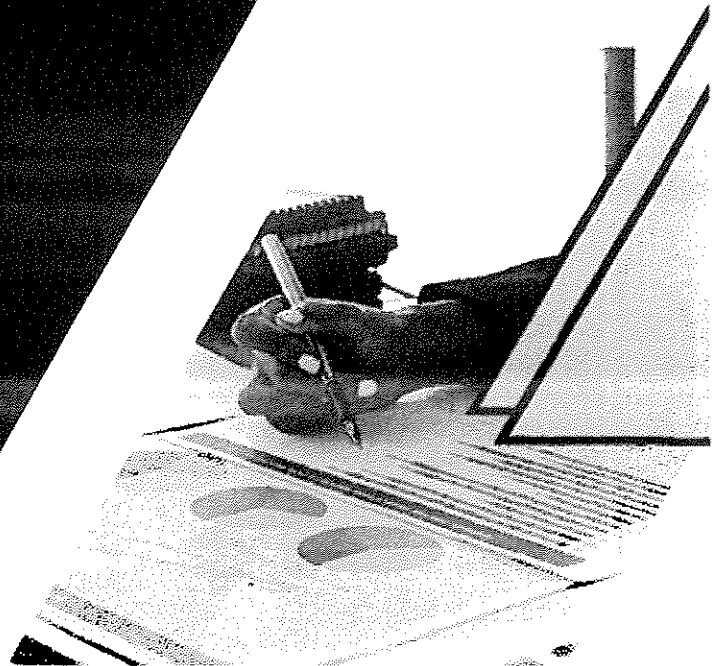

Business Consulting

Grow, adapt, strengthen operations, attract resources, and support goal achievement

- Grant Management
- Talent Development
- Capacity Building
- Project Management



Community Engagement

Connect interested parties, foster meaningful dialogue, and drive inclusive community-led solutions

- Neighborhood Sustainability
- Housing Instability & Homeless Prevention
- Public Services & Benefits
- Education & Opportunities



Event Design

Curate experiences to inspire creativity, deepen engagement, and align people around shared goals

- Personal Empowerment
- Social Capital Cultivation
- Professional Development
- Resource Development

Recommended for You

Business Consulting **Project Management**

Our Project Management services are uniquely positioned to support the goals of this opportunity. We define Project Management as a structured and adaptable process that drives progress, optimizes resources, mitigates risks, and delivers measurable outcomes. Rooted in our commitment to equity and community-driven solutions, our model is trauma-informed, inclusive, and continuously evolving based on community needs and feedback.

Our Model

Our Project Management model is centered around six core components: centralized knowledge sharing, role clarity, contributor alignment, process optimization, progress tracking and proactive challenge resolution. Our process is efficient, effective and designed to maximize capacity.

Primary Activities

CONTRIBUTOR COORDINATION & COMMUNICATIONS

- Facilitating collaboration and alignment among collaborators to enhance project impact
- Coordinating clear communication channels that foster trust and drive shared goals

DATA MANAGEMENT & REPORTING

- Curating data-driven strategies to measure success, track progress, and inform decision-making
- Coordinating data collection, analysis, and reporting to ensure transparency and continuous project improvement

MATERIAL & RESOURCE DEVELOPMENT

- Creating tailored toolkits, templates, and frameworks that streamline project implementation and simplify contributor accessibility
- Identifying, curating, and organizing key resources that support project success

ACTIVITY DEVELOPMENT & STRATEGIC PLANNING

- Designing and structuring activities that align with project goals and community needs
- Developing equitable strategies that integrate best practices, drive engagement, and support scalability

Project Interpretation

Overview

The Power Initiative, in partnership with community contributors, proposes the following approach to strategically deploy City of Flint carryover funds to strengthen youth development, mental health supports, and cross-sector collaboration. This approach will activate three focused investment buckets that build on existing community assets, past cohort learning, and proven program infrastructure. All funds will be deployed and completed by September 30, with measurable outcomes and clear reporting. This proposal centers youth, strengthens families, and leverages collaborative sponsorship models to maximize impact per dollar invested.

Purpose & Rationale

Flint's young people continue to navigate academic disruption, mental health strain, and limited access to structured developmental opportunities. At the same time, the city has strong local organizations, prior cohort investments, and community partnerships that can be activated quickly.

This proposal does not seek to create something new from scratch. Instead, it accelerates and scales what is already working.

By rolling out this initiative in early spring, the City can:

- Stabilize youth during a critical pre-summer window
- Strengthen protective factors before summer programming begins
- Reinforce mental health supports in accessible, community-based settings
- Maximize probability of grant compliance and timely spend down of funds

Accountability & Reporting

Our team will implement the following:

- Participant tracking
- Partnership documentation
- Attendance and engagement metrics
- Narrative impact summaries
- Financial reconciliation by September 30

This initiative will be fully documented and positioned as a scalable model for future City partnership.

Project Options

Our approach proposes 3 different project options. Each option can be implemented singularly or scaled down and implemented as a mixture of multiple of multiple options.

1 Collaborative Project

This pathway advances implementation of previously developed cohort-based and collaborative initiatives that have already completed planning phases but require activation funding to move into execution.

2 Community Sponsorships

This pathway establishes a sponsorship tier designed specifically for Flint-based organizations that did not receive prior ReCAST funding but are actively contributing to youth resilience, trauma-informed programming, and community stabilization efforts.

3 Youth Engagement

This pathway proposes a targeted pilot focused on male-led youth mental health initiatives designed to resonate authentically with young people and increase effectiveness in connecting them to support systems. This would serve as a pilot model for culturally relevant, male-led youth engagement strategies that address stigma, build trust, and promote healthy coping mechanisms.

Project Scope

Collaborative Project

This bucket builds on past cohort projects and collaborative planning efforts that have already generated ideas, partnerships, and infrastructure but require funding to move forward.

Funds will support:

- Participation stipends for prior cohort partners
- Cross-organizational coordination and facilitation
- Shared resource development
- Technical assistance to ensure execution readiness

Outcome: Move past planning into implementation, developing tangible outputs and strengthening cross-organization alignment.

Community Sponsorships

Recognizing the barriers grassroots organizations face when facilitating community activities, this bucket prioritizes financial support and capacity building of existing community groups and initiatives.

Funds will support:

- Community events, activities and programs
- Nonprofit capacity building and technical assistance
- Supply and material requests

Outcome: Bridge funding gaps and build relationships with underfunded organizations, promote access to resources and support.

Youth Engagement

Building upon last year's Youth Mental Health Summit model, this bucket engages youth in the development and implementation of mental health and wellness related activities.

Funds will support:

- Group-based mental and physical wellness activities
- Youth consultant development and stipend
- Community partnerships

Outcome: Curate safe spaces for youth, promote personal and professional development of young people.

Investment

Our budget balances the scope and quality of the work while remaining cost-efficient. Each line item reflects the value of the work required to deliver a comprehensive and actionable plan. **Total Cumulative Budget: \$130,000**

Line Item	Value	Percentage
COLLABORATIVE PROJECT: Youth Event Coordination; Youth Consultant Development & Management (September 2026)		
Base Service Fee	\$29,000	59%
Project Planning and Development**	Included in Base Service Fee	
Consultant & Activity Expenses	\$15,000	31%
Supplies, Digital Facilities, and Operations	\$5,000	10%
Event Expenses**	TBD	0%
TOTAL	\$49,000	100%
COMMUNITY SPONSORSHIPS: Community Award Distribution		
Base Service Fee	\$6,000	13%
Project Planning and Development**	Included in Base Service Fee	
Sponsorship Awards	\$40,000	87%
TOTAL	46,000	100%
YOUTH ENGAGEMENT: Summer Job Program Training Event & Host Site Coordination		
Base Service Fee	\$22,000	63%
Project Planning & Development**	Included in Base Service Fee	
Partnerships & Project Expenses	\$8,000	23%
Supplies, Digital Facilities, and Operations	\$5,000	14%
Event Expenses**	TBD	0%
TOTAL	\$35,000	100%

**Proposal can be negotiated and adjusted to fit your specific budget and organizational needs.

Base Service Fee: Covers the foundational work necessary to launch the project, including initial consultations, project setup, and administrative preparation. Ensures that all systems and processes are in place for a smooth and efficient start.

Project Planning and Development: Accounts for the time spent conducting assessments, compiling and analyzing data, preparing reports, and developing the strategic plan.

Partnerships and Project Expenses: Allocated funds to cover expenses related to community partnerships, consultant wages, facilitation, and project or youth activity implementation.

Supplies, Digital Facilities, and Operations: Covers necessary supplies, digital tools, and operational expenses. This includes materials for contributor sessions, data collection tools, virtual meeting platforms, and other resources needed.

Event Expenses: Cost of supplies, vendors, food swag, promotional items, etc. Our proposed cost does not cover day of implementation expenses.

Let's Connect



The Power Initiative
3328 Walton Avenue
Flint, MI 48504
810.874.0353
www.thepowerinitiative.org
info@thepowerinitiative.org

At The Power Initiative, we're more than consultants—we're collaborators dedicated to helping your organization impact transformative change. We are honored by the opportunity to work alongside your team to craft a strategic plan that not only meets today's needs but also sets the stage for a stronger, more sustainable future.

We're ready to dive in and begin this journey together — **Let's build something powerful.**





STAFF REVIEW FORM

Effective: April 1, 2026

(Do not alter or modify this form without written permission from the City Administrator)

TODAY'S DATE: 4/20/2026

BID PROPOSAL #:

AGENDA ITEM TITLE: Recast Carry Over Funds 2025-2026

PREPARED BY: Shelly Sparks-Green

VENDOR NAME: Power Initiative

Section 1. BACKGROUND/SUMMARY OF PROPOSED ACTION..

Vendor Compliance (This vendor has been properly vetted and the responses are below) :

Federal gov't	(All documentation current, no violations)	<input checked="" type="checkbox"/> YES	<input type="checkbox"/> NO
State gov't	(All documentation current, no violations)	<input checked="" type="checkbox"/> YES	<input type="checkbox"/> NO
City of Flint	(All documentation current, no violations)	<input checked="" type="checkbox"/> YES	<input type="checkbox"/> NO

The requesting authority is validating that this vendor has been in full compliance with all past contract provisions and has not violated the terms of any contract with the City of Flint.

NOTE: Preparer MUST include a response to the conditions below:

- Did we do an assessment of first consideration to internal City of Flint staff and resources (explain)?
- Why was this vendor chosen?
- What history does this vendor have with the City of Flint?
- What steps will be taken to do a post-performance of the vendor?

The Power Initiative started in 2020 in Flint, Michigan, with a clear purpose: to leverage the resources and opportunities around us by fostering true community and redefining what community progress looks like. We saw opportunities demanding fresh ideas and real solutions, so we stepped in — not just to meet the present but to help shape the future. We're all about creating real, transformative change. We know the challenges in our systems run deep, but we also believe in unlocking opportunities that already exist within those frameworks. Many organizations have the resources they need—it's just about finding the right strategies to make those resources work harder, smarter, and better. That's where we come in: to close the gaps, maximize potential, and create solutions that are both sustainable and centered on people. At our core, we believe people are powerful. When equipped with the right tools and support, they can tackle even the toughest challenges.

This year Recast is seeking to spend its carried over funds with an organization that can help reach the final goals of recast which include funding for the smaller applicant organizations, youth event coordination, and job training and orientation (see attached proposal). Power Initiative was chosen because of their past performance and their connection to the Recast processes. Their work is grounded in trust, collaboration, and respect and values that allow them to deliver customized, innovative solutions that truly reflect the unique goals of each organization.

In the past 2 years Power Initiative has worked with Greater Flint health coalition and the City of Flint as part of the Recast grant serving as the coordinator for mini grants program scoring and selection process, providing



STAFF REVIEW FORM

Effective: April 1, 2026

(Do not alter or modify this form without written permission from the City Administrator)

grant writing training and funding for the recipients that did not receive mini grants to improve their application for the next year RFP process.

PROCUREMENT (MUST BE SPECIFIED)

Please specify how this vendor was identified: (Check one)

- Sole Source (Please attach sole source statement to requisition)
- Competitive Bid Process (Please attach bid tabulation/documents to requisition)
- Cooperative Contract (MIDeal, Sourcewell, GSA, or other municipality)
 - *Contract must be attached to your requisition and contract must appear on the vendor's quote for goods/services
- (3) Quotes (please attach all quotes to your requisition)

Section 2. PREVIOUS ALLOCATIONS (INCLUDE ALL ACCOUNTS USED FOR THIS PURPOSE)/ PROVIDE RESOLUTION OR CONTRACT INFORMATION THAT APPLIES..

Fiscal Year	Account	PO Number	FY PO Amount	FY Expensed	Resolution
2026	296-649.700-801.000	26-008899	\$25,000	\$25,000	
2025	296-649.700-801.000	25-008230	\$70,000	\$70,000	

Section 3. POSSIBLE BENEFIT TO THE CITY OF FLINT (RESIDENTS AND/OR CITY OPERATIONS) INCLUDE PARTNERSHIPS AND COLLABORATIONS..

This project will benefit the city of Flint residents, organizations, and strengthen the city partnerships in three ways:

1. Collaborative Projects: This bucket builds on past cohort projects and collaborative planning efforts that have already generated ideas, partnerships, and infrastructure but require funding to move



STAFF REVIEW FORM

Effective: April 1, 2026

(Do not alter or modify this form without written permission from the City Administrator)

forward. Funds will support: Participation stipends for prior cohort partners Cross-organizational coordination and facilitation Shared resource development Technical assistance to ensure execution readiness Outcome: Move past planning into implementation, developing tangible outputs and strengthening cross-organization alignment.

2. Community Sponsorships_ Recognizing the barriers grassroots organizations face when facilitating community activities, this bucket prioritizes financial support and capacity building of existing community groups and initiatives. Funds will support: Community events, activities and programs Nonprofit capacity building and technical assistance Supply and material requests Outcome: Bridge funding gaps and build relationships with underfunded organizations, promote access to resources and support.

3. Youth Engagement - Building upon last year's Youth Mental Health Summit model, this bucket engages youth in the development and implementation of mental health and wellness related activities. Funds will support: Group-based mental and physical wellness activities Youth consultant development and stipend Community partnerships Outcome: Curate safe spaces for youth, promote personal and professional development of young people.

Section 4. FINANCIAL IMPLICATIONS..

IF ARPA related Expenditure:

Has this request been reviewed by E&Y Firm: YES NO IF NO, PLEASE EXPLAIN:

NOTE: Accountant MUST include the following information:

- What is the total amount budgeted for this purpose?
- What percentage is being spent with this vendor?
- What is the justification for spending this amount of money with this vendor?
- What percentage is being spent out of each line item used in this request?
- List all the known budgeted funds from that line item.

1. \$140,860.84

2. 99.38%

3. Per proposal submitted

4. There is currently \$105,969.36 available in 296-649-700-801.000 FHHS21RECAST. This contract will require a budget amendment of \$34,030.64 to be reduced from wage/fringe accounts. Once the budget amendment is complete, this contract will be 100% of the remaining budget for the grant professional services account. \$660,952.67 is also currently encumbered in the same account which are budgeted for the other 4 year 5 ReCAST implementation partner subawards.

5. Known budgeted funds include:

Genesee Health System Year 5 Subaward: \$149,898 (\$68,651.38 remaining as of 5/6/26)

Greater Flint Health Coalition Year 5 Subaward: \$475,836 (\$413,290.24 remaining as of 5/6/26)

Crim Fitness Foundation Year 5 Subaward: \$104,543 (\$78,886.05 remaining as of 5/6/26)

Michigan State University data evaluation: \$100,125 (\$100,125 remaining as of 5/6/26)



STAFF REVIEW FORM

Effective: April 1, 2026

(Do not alter or modify this form without written permission from the City Administrator)

	1 = Poor	2 = Fair	3 = Sufficient	4 = Good	5 = Excellent
Job Knowledge:	<input type="checkbox"/>	<input type="checkbox"/>	<input type="checkbox"/>	<input type="checkbox"/>	<input checked="" type="checkbox"/>
Work Quality:	<input type="checkbox"/>	<input type="checkbox"/>	<input type="checkbox"/>	<input type="checkbox"/>	<input checked="" type="checkbox"/>
Timeliness:	<input type="checkbox"/>	<input type="checkbox"/>	<input type="checkbox"/>	<input type="checkbox"/>	<input checked="" type="checkbox"/>
Compliance with Contract:	<input type="checkbox"/>	<input type="checkbox"/>	<input type="checkbox"/>	<input type="checkbox"/>	<input checked="" type="checkbox"/>
Warranty (If Product):	NA <input type="checkbox"/>	<input type="checkbox"/>	<input type="checkbox"/>	<input type="checkbox"/>	<input type="checkbox"/>
Responsiveness:	<input type="checkbox"/>	<input type="checkbox"/>	<input type="checkbox"/>	<input type="checkbox"/>	<input checked="" type="checkbox"/>
Cost Effectiveness:	<input type="checkbox"/>	<input type="checkbox"/>	<input type="checkbox"/>	<input type="checkbox"/>	<input checked="" type="checkbox"/>
Dependability:	<input type="checkbox"/>	<input type="checkbox"/>	<input type="checkbox"/>	<input type="checkbox"/>	<input checked="" type="checkbox"/>
Total Performance:	<input type="checkbox"/>	<input type="checkbox"/>	<input type="checkbox"/>	<input type="checkbox"/>	<input checked="" type="checkbox"/>
Overall Rating:	<input type="checkbox"/>	<input type="checkbox"/>	<input type="checkbox"/>	<input type="checkbox"/>	<input checked="" type="checkbox"/>

DEFECTS (IF ANY): IF CHECKED, PLEASE EXPLAIN:

NA

Performance / Other Comments:

NA

REVIEWER'S SIGNATURE: Michelle Scott

Date: May 12, 2026



STAFF REVIEW FORM

Effective: April 1, 2026

(Do not alter or modify this form without written permission from the City Administrator)

BUDGETED EXPENDITURE? YES NO IF NO, PLEASE EXPLAIN:

Dept.	Name of Account	Account Number	Grant CODE	Amount
Mayor	Professional Services	296-649.700-801.000	FHHS2IRECAST	\$140,000
FY26 GRAND TOTAL				\$140,000

WHEN APPLICABLE, IF MORE THAN ONE (1) YEAR, PLEASE ESTIMATE TOTAL AMOUNT FOR EACH BUDGET YEAR: (This will depend on the term of the bid proposal)

BUDGET YEAR 1: _____

BUDGET YEAR 2: _____

BUDGET YEAR 3: _____

OTHER IMPLICATIONS (i.e., collective bargaining).. _____

PRE-ENCUMBERED? YES NO REQUISITION NO: _____

ACCOUNTING APPROVAL: *[Signature]* Date: 05/12/2026

WILL YOUR DEPARTMENT NEED A CONTRACT? YES NO

Section 5. RESOLUTION DEFENSE TEAM..

(Place the names of those who can defend this resolution at City Council)

	NAME	PHONE NUMBER
1	Michelle Scott (810) 252-3500	Michelle Scott (810) 252-3500 mscott@cityofflint.com
2	Shelly Sparks-Green	(810) 766-7346 ext 2049 ssgreen@cityofflint.com
3		



STAFF REVIEW FORM

Effective: April 1, 2026

(Do not alter or modify this form without written permission from the City Administrator)

4		
---	--	--

STAFF RECOMMENDATION: (PLEASE SELECT): APPROVED NOT APPROVED

DEPARTMENT HEAD SIGNATURE: [Signature]
City of Flint, Michigan May 12, 2026 15:30:00 EDT
(Name, Title)

ADMINISTRATION APPROVAL: [Signature]
(\$20,000 or above spending authorizations)

Section 6. VENDOR EVALUATION..

Business Title: Power Initiative	Vendor ID:000000921 7
Review Period: 05/12/2026	Department: City Of Flint ReCast
Project Name: Collaborative Youth Engagement Project	Project Type: ReCast Sub Award

Vendor Goals:

This project focuses on engaging youth as active contributors in the design and implementation of a community-based event. Using a FUBU (for youth, by youth) approach, a cohort of youth consultants will be supported to shape the direction, priorities, and overall approach of the experience. The Power Initiative will facilitate youth consultant development, provide structure and guidance, and coordinate the implementation of the event in partnership with community collaborators. This includes managing logistics, aligning partners, and ensuring the event is executed effectively. The goal is to build youth leadership and ownership while delivering a coordinated event that reflects youth voice and promotes connection, engagement, and well-being. The following are three projects to be obtained with this project goal:

- Collaborative Project- Youth Engagement
- Community Sponsorships
- Youth Engagement-Summer Job Program



Form Revision Date 07/2016

ANNUAL STATEMENT
For use by DOMESTIC LIMITED LIABILITY COMPANY
(Required by Section 207, Act 23, Public Act of 1993)

Identification Number: 802480769

Annual Statement Filing Year: 2025

1. Limited Liability Company Name:

XXXXXXXXXXXX

2. The street address of the limited liability company's registered office and name of the resident agent at that office:

1. Resident Agent Name: ASHNEE DUNNING
2. Street Address: 3328 WALTON AVENUE
Apt/Suite/Other:
City: FLINT
State: MI Zip Code: 48504

3. Mailing address of the registered office:

P.O. Box or Street Address: 3328 WALTON AVENUE
Apt/Suite/Other:
City: FLINT
State: Zip Code: 48504

This annual statement must be signed by a member, manager, or an authorized agent.

Signed this 13th Day of February, 2025 by:

Signature	Title	Title if "Other" was selected
Ashnee Dunning	Member	

By selecting ACCEPT, I hereby acknowledge that this electronic document is being signed in accordance with the Act. I further certify that to the best of my knowledge the information provided is true, accurate, and in compliance with the Act.

Decline Accept

MICHIGAN DEPARTMENT OF LICENSING AND REGULATORY AFFAIRS
FILING ENDORSEMENT

This is to Certify that the 2025 ANNUAL STATEMENT

for

THE POWER INITIATIVE LLC

ID Number: 802480769

received by electronic transmission on February 13, 2025 , is hereby endorsed.

Filed on February 15, 2025 , by the Administrator.

The document is effective on the date filed, unless a subsequent effective date within 90 days after received date is stated in the document.



In testimony whereof, I have hereunto set my hand and affixed the Seal of the Department, in the City of Lansing, this 15th day of February, 2025.

Linda Clegg

Linda Clegg, Director

Corporations, Securities & Commercial Licensing Bureau

- Home
- Search
- Forms

Business Search

As of 6/9/2026:

- Business Filings are processed through 06/07/2026.
- Renewals and Restorations (for entities returning to good standing) are processed through 06/08/2026.

To file a document or annual report/statement for an existing entity, search for the entity, select Request Access from the slide-out drawer, complete the questions, refresh the webpage, and select File Subsequent Document or File Annual Report/Statement.

The same process applies to order certificates and copies.

You must be logged in to file documents or order certificates and copies. Click on the Login button in the top right. If you do not have an account, create one. The credentials from the previous system did not transfer to this system.

Business Search Info:



Search by name or file number *

Advanced ▾

Results: 1

Name	Filing Date	Status	AR Standing	Entity Type	Entity ID#	Agent	AR Due Date
	07/15/2020	Active	Good	Domestic Limited Liability Company	802480769	ASHNEE DUNNING	02/15/2027



260221

RESOLUTION NO.: _____

PRESENTED: 6-17-2026

ADOPTED: _____

Proposal: 26000513
Tracking: A0658

BY THE CITY ADMINISTRATOR:

**RESOLUTION AUTHORIZING THE CITY TO ENTER INTO AGREEMENT WITH
BLACKOUT CONSTRUCTION LLC FOR THE PURPOSES OF ACCESSIBILITY
MODIFICATIONS OF 16 SINGLE FAMILY HOMES UNDER THE MSHDA GRANT
NDD-2023-49-MIN**

WHEREAS, In December of 2024, The City Council accepted the award of \$472,000.00 from the Michigan State House Development Authority (MSHDA) for the City’s Occupied Housing Accessibility Rehab Program through MI Neighborhood 1.0 Grant NDD-2023-49-MIN. (Performance Period October 2024-August 31st, 2026). Which was received and approved through resolution 240484-T adopted December 16th, 2024.

WHEREAS, the goal of the Accessibility Rehab program funded from MSHDA’s MI Neighborhood grant, is the successful modification of 19 single family homes throughout the City of Flint, 19 of which have already been identified, processed, vetted, and currently working with the occupants.

WHEREAS, Blackout Construction, LLC is a licensed and insured construction company, familiar with both this specific project and the type of work expected throughout this contract.

WHEREAS, Blackout Construction, LLC, through a competitive bid process, placed a bid on 19 of the 19 properties.

WHEREAS, Blackout Construction, LLC was selected to perform accessibility modifications for 16 of the 19 properties they bid on.

WHEREAS, Blackout Construction LLC will enter a performance-based contract over the duration of the grant program, providing accessibility rehabs for 16 of the 19 properties, and will ensure compliance with both City of Flint requirements and MSHDA MI Neighborhood 1.0 compliance.

WHEREAS, Funding is to come from the following account(s):

Account Number	Account Name/Grant Code	Amount
296-704.735-801.000	SMSHD-MICH23	\$228,088.90



RESOLUTION NO.: _____

PRESENTED: _____

ADOPTED: _____

Proposal: 26000513

Tracking: A0658

IT IS RESOLVED, that the appropriate City officials are hereby authorized to award MI Neighborhood 1.0 funding and to enter into contract with Backout Construction, LLC for the remainder of the grant period, up to August 31st, 2026 in a total amount not to exceed \$228,088.90 for services relating to their performing of accessibility modifications to 16 single family homes within the City of Flint as part of the Occupied Housing Accessibility Rehab Program.

APPROVED AS TO FORM:



JoAnne Gurley (Jun 5, 2026 11:10:55 EDT)
Joanne Gurley, City Attorney

APPROVED AS TO FINANCE:



Paul Borle For (Jun 5, 2026 11:46:41 EDT)
Phillip Moore, Chief Financial Officer

FOR THE CITY OF FLINT:



Clyde Edwards/ A0657 (Jun 5, 2026 14:03:08 EDT)
Clyde Edwards, City Administrator

APPROVED BY CITY COUNCIL:



STAFF REVIEW FORM

Effective: April 1, 2026

(Do not alter or modify this form without written permission from the City Administrator)

TODAY'S DATE: June 2nd, 2026

BID PROPOSAL #: 26000513

AGENDA ITEM TITLE: RESOLUTION AUTHORIZING THE CITY TO ENTER INTO AGREEMENT WITH BLACKOUT CONSTRUCTION LLC FOR THE PURPOSES OF ACCESSIBILITY MODIFICATIONS OF 16 SINGLE FAMILY HOMES UNDER THE MSHDA GRANT NDD-2023-49-MIN

PREPARED BY: Shelby Bader- Department of Business and Community Services

VENDOR NAME: Blackout Construction, LLC

Section 1. BACKGROUND/SUMMARY OF PROPOSED ACTION..

Vendor Compliance (This vendor has been properly vetted and the responses are below) :

Federal gov't	(All documentation current, no violations)	<input checked="" type="checkbox"/> YES	<input type="checkbox"/> NO
State gov't	(All documentation current, no violations)	<input checked="" type="checkbox"/> YES	<input type="checkbox"/> NO
City of Flint	(All documentation current, no violations)	<input checked="" type="checkbox"/> YES	<input type="checkbox"/> NO

The requesting authority is validating that this vendor has been in full compliance with all past contract provisions and has not violated the terms of any contract with the City of Flint.

NOTE: Preparer MUST include a response to the conditions below:

- Did we do an assessment of first consideration to internal City of Flint staff and resources (explain)?
- Why was this vendor chosen?
- What history does this vendor have with the City of Flint?
- What steps will be taken to do a post-performance of the vendor?

No assessment completed as this work cannot be conducted by City of Flint staff.
 The Vendor was chosen based upon a competitive bid process, as well as cost reasonableness ensured through assistance from Genesee County Habitat for Humanity.
 The vendor has no prior history working with the City of Flint.
 Before final payment is issued, the vendor must provided finalized permits, invoices, and other compliance documentation required by both MSHDA and the Department of Business and Community Services for each of the 16 residencies they have worked on.

PROCUREMENT (MUST BE SPECIFIED)

Please specify how this vendor was identified: (Check one)

- Sole Source (Please attach sole source statement to requisition)
- Competitive Bid Process (Please attach bid tabulation/documents to requisition)



STAFF REVIEW FORM

Effective: April 1, 2026

(Do not alter or modify this form without written permission from the City Administrator)

- Cooperative Contract (MIDeal, Sourcewell, GSA, or other municipality)
*Contract must be attached to your requisition and contract must appear on the vendor's quote for goods/services
- (3) Quotes (please attach all quotes to your requisition)

Section 2. PREVIOUS ALLOCATIONS (INCLUDE ALL ACCOUNTS USED FOR THIS PURPOSE)/ PROVIDE RESOLUTION OR CONTRACT INFORMATION THAT APPLIES..

Fiscal Year	Account	PO Number	FY PO Amount	FY Expensed	Resolution
NA					

The vendor has not conducted business with The City of Flint previously.

Section 3. POSSIBLE BENEFIT TO THE CITY OF FLINT (RESIDENTS AND/OR CITY OPERATIONS) INCLUDE PARTNERSHIPS AND COLLABORATIONS..

The benefits to the City of Flint are that 16 of a total 19 low and moderate income residents with accessibility needs, including both renters and homeowners residing in single family homes within the City are going to receive accessibility updates to their home.

Partners are the Michigan State Housing Development Authority, through their MI Neighborhood 1.0 program which provided the \$472,000.00 of funding for this project.

Genesee County Habitat for Humanity provided scopes of work to City of Flint staff so that they could use them as a baseline to help bidders during the competitive bid process and ensure cost reasonableness throughout the process.



STAFF REVIEW FORM

Effective: April 1, 2026

(Do not alter or modify this form without written permission from the City Administrator)

Section 4. FINANCIAL IMPLICATIONS..

IF ARPA related Expenditure:

Has this request been reviewed by E&Y Firm: YES NO IF NO, PLEASE EXPLAIN:

This is not affiliated with ARPA.

NOTE: Accountant MUST include the following information:

- What is the total amount budgeted for this purpose?
- What percentage is being spent with this vendor?
- What is the justification for spending this amount of money with this vendor?
- What percentage is being spent out of each line item used in this request?
- List all the known budgeted funds from that line item.

Blackout Construction, LLC is budgeted 48.32% not to exceed \$228,088.90 of the \$472,000.00 total grant allocation.

\$472,000.00 has been allocated to the City of Flint for this project via the State of Michigan and resoluted through council 240484-T adopted 12/16/2024.

Blackout Construction LLC is one of two companies were the only reasonable bids received through our competitive bid process as well as having applicable experience and certifications relevant to this project.

BUDGETED EXPENDITURE? YES NO IF NO, PLEASE EXPLAIN:

Dept.	Name of Account	Account Number	Grant CODE	Amount
DBCS	SMSHD-MICH23	296-704.735-801.000		\$228,088.90
FY26 GRAND TOTAL				\$228,088.90

WHEN APPLICABLE, IF MORE THAN ONE (1) YEAR, PLEASE ESTIMATE TOTAL AMOUNT FOR EACH BUDGET YEAR: (This will depend on the term of the bid proposal)



STAFF REVIEW FORM

Effective: April 1, 2026

(Do not alter or modify this form without written permission from the City Administrator)

BUDGET YEAR 1: \$228,088.90
 BUDGET YEAR 2: NA
 BUDGET YEAR 3: NA

OTHER IMPLICATIONS (i.e., collective bargaining).. These funds must be fully expended by August 31st.

PRE-ENCUMBERED? YES NO REQUISITION NO: _____

ACCOUNTING APPROVAL: Carissa Dotson Date: _____

WILL YOUR DEPARTMENT NEED A CONTRACT? YES NO

Section 5. RESOLUTION DEFENSE TEAM..

(Place the names of those who can defend this resolution at City Council)

	NAME	PHONE NUMBER
1	Roderick Slaughter	(810) 766-7426 x 3019
2	Shelby Bader	810-766-7426 ext. 3009
3	Celeste Lord	810-766-7426 ext. 3031
4		

STAFF RECOMMENDATION: (PLEASE SELECT): APPROVED NOT APPROVED

DEPARTMENT HEAD SIGNATURE: Rod Slaughter Deputy Director

 (Name, Title)

ADMINISTRATION APPROVAL: CDE

 Clyde Edwards (Jun 2, 2026 16:11:37 EDT)

Section 6. VENDOR EVALUATION..



STAFF REVIEW FORM

Effective: April 1, 2026

(Do not alter or modify this form without written permission from the City Administrator)

Business Title:

Vendor ID:

Review Period:

Department:

Project Name:

Project Type:

Vendor Goals:

1 = Poor 2 = Fair 3 = Sufficient 4 = Good 5 = Excellent

Job Knowledge:

Work Quality:

Timeliness:

Compliance with Contract:

Warranty (If Product):

Responsiveness:

Cost Effectiveness:

Dependability:

Total Performance:

Overall Rating:

DEFECTS (IF ANY): IF CHECKED, PLEASE EXPLAIN:



STAFF REVIEW FORM

Effective: April 1, 2026

(Do not alter or modify this form without written permission from the City Administrator)

Performance / Other Comments:

REVIEWER'S SIGNATURE: _____

Date: _____

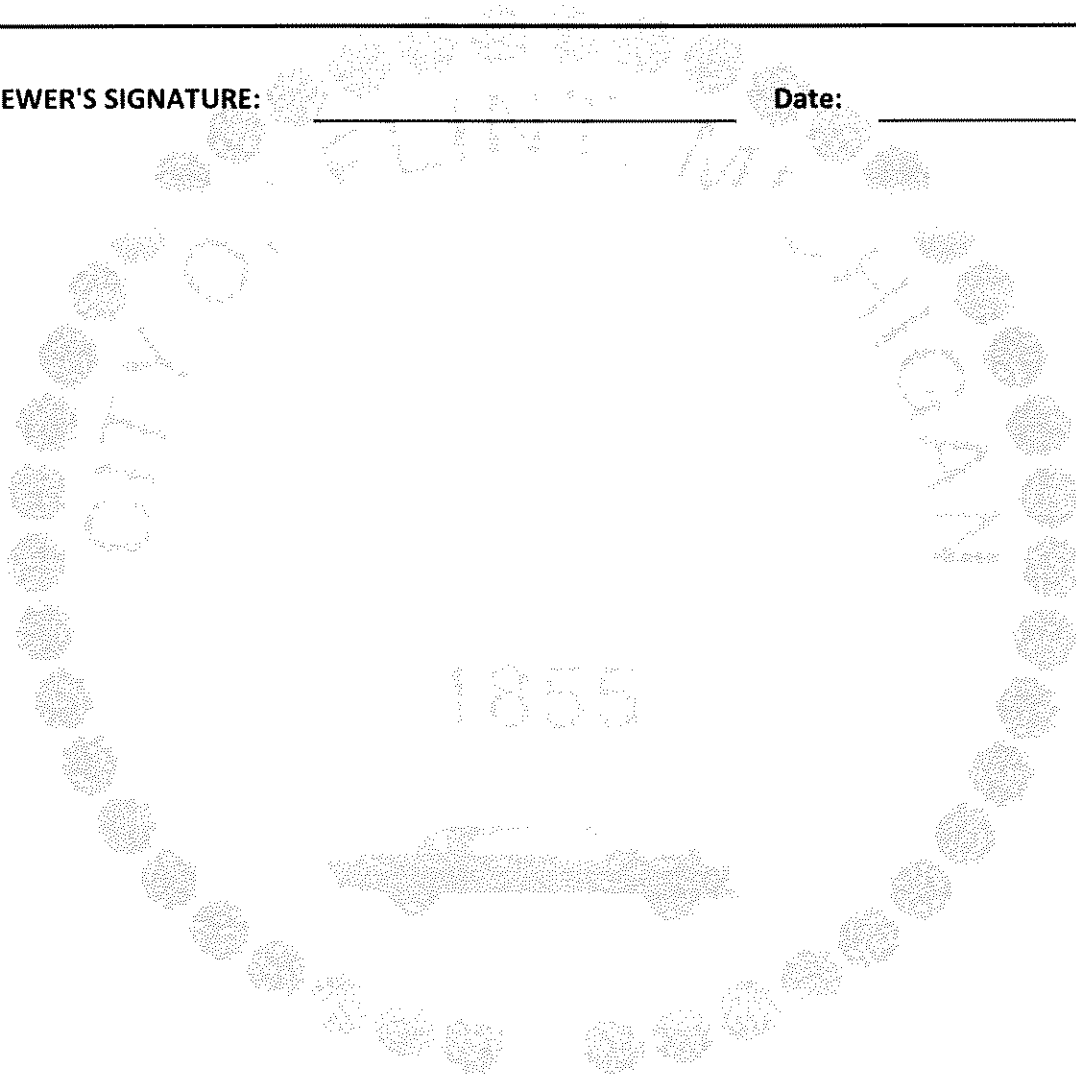

Property Number	Bid	30% Contingency	Property Total
Property 1	10571	3171.3	13742.3
Property 2	9676	2902.8	12578.8
Property 3	14673	4401.9	19074.9
Property 4	16580	4974	21554
Property 5			
Property 6	2500	750	3250
Property 7	12953	3885.9	16838.9
Property 8	7220	2166	9386
Property 9	8288	2486.4	10774.4
Property 10	15150	4545	19695
Property 11	16790	5037	21827
Property 12	10148	3044.4	13192.4
Property 13			
Property 14	12020	3606	15626
Property 15	13238	3971.4	17209.4
Property 16	14470	4341	18811
Property 17	7038	2111.4	9149.4
Property 18			
Property 19	4138	1241.4	5379.4
Blackout Total			\$228,088.90



**SEALED PROPOSALS RECEIVED IN THE DIVISION OF PURCHASES & SUPPLIES
CONSTRUCTION SERVICES FOR SCATTERED SINGLE-FAMILY HOME ADA REHABILITATION
PROPOSAL# 26000513**

Approximate Annual Quantities – Not Guaranteed
Furnish as requested for the period 07/1/26 – 6/30/27

Property #	Blackout Construction LLC, Mt Clemons, MI	Beatrice Construction LLC, Clinton Twp, MI	Servpro, Flint Twp, MI
#1	\$10,571.00	No bid	\$ 13,898.29
#2	\$9,676.00	No bid	\$ 10,578.93
#3	\$14,673.00	No bid	\$ 60,235.08
#4	\$16,580.00	No bid	\$ 79,006.80
#5	\$18,893.00	\$18,095.00	\$ 40,085.63
#6	\$2,500.00	\$12,950.00	\$ 14,873.84
#7	\$12,953.00	No bid	\$ 92,725.51
#8	\$7,220.00	No bid	\$ 16,358.30
#9	\$8,288.00	No bid	\$ 28,963.77
#10	\$15,150.00	No bid	\$ 35,496.92
#11	\$16,790.00	No bid	\$ 94,245.36
#12	\$10,148.00	\$20,069.00	\$ 68,535.05
#13	\$5,141.50	\$11,340.00	\$ 14,390.22
#14	\$12,020.00	No bid	\$ 31,122.00
#15	\$13,238.00	No bid	\$ 28,567.11
#16	\$14,470.00	No bid	\$ 38,825.58
#17	\$7,038.00	No bid	\$

A SPECIAL NOTE FROM THE PURCHASING DIVISION

Bid results posted are before evaluation team review and award recommendation.



			16,192.28
#18	\$38,700.00	\$35,640.00	\$ 61,474.07
#19	\$4,138.00	No bid	\$ 20,348.15
GRAND TOTAL	\$238,187.50	\$98,094.00 (for 5 properties only)	\$ 765,922.89
Notes			**Original total was quoted \$771,288.43. The yellow highlighted tab reflects the actual total.

A SPECIAL NOTE FROM THE PURCHASING DIVISION

Bid results posted are before evaluation team review and award recommendation.

Sheldon Neeley
Mayor of Flint

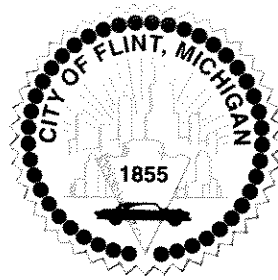

CITY OF FLINT SERVICES AGREEMENT

This agreement (hereinafter "Agreement") by and between the City of Flint, a Michigan Municipal Corporation, 1101 S. Saginaw Street, Flint, MI 48502, hereinafter referred to as the ("City"), and Blackout Construction, LLC. hereafter referred to as ("Vendor"), and both collectively, the Parties.

The City desires to enter into an agreement for the rehabilitation of 16 Properties as part of the Occupied Accessibility rehab Program funded through Michigan State Housing Development Authority's (MSHDA) MI Neighborhood 1.0 program and the Vendor has agreed to provide the referenced services. **THEREFORE**, the Parties agree as follows:

1. **Applicable Law:** This Agreement and all related disputes shall be governed by and interpreted in accordance with the laws of the State of Michigan.
2. **Scope of Services:** The Vendor shall provide Accessibility rehabilitation upgrades to 16 single family properties located throughout the City of Flint, utilizing the scopes of services provided in their bid. SEE ATTACHMENT A. Incorporated by Reference for Blackout Construction, LLC Accessibility Rehab Upgrades \$228,088.90 all documents and attachments.
3. The Vendor shall ensure that all parties agree on the scope of work prior to any work being completed, and that each individual property has a completed contract between the home owner, the City, and the Contractor.
4. **Compensation:** The City shall reimburse Blackout Construction, LLC. in an amount Not-To-Exceed (\$228,088.90).
5. **Duties of the City:** The City will endeavor to complete the following deliverables in accordance with the timeline and scope described herein:
 - a. The primary City contact for the Vendor shall be Shelby Bader, Community Development Program Manager in the Community Services Division. sbader@cityofflint.com (810) 386-5068
 - b. Provide any necessary information, forms, assistance in reach residents, and completing obligations under this Agreement and as required by the City;
6. **Term of Agreement:** This Agreement shall commence on June 2nd, 2026 and end on August 31st, 2026. This agreement is in full force and effect for the period specified unless amended by both Parties in writing.
7. **Claims and Disputes:** Vendor agrees that for all claims, disputes, and other matters arising out of or relating to this agreement, Vendor must first request the City's consent to arbitrate. Such a request must be made within 30 days from the date Vendor learns of or should have known the facts giving rise to the claim, dispute or question.
 - a. Notice of a request for arbitration must be submitted in writing by certified mail or personal service upon the City Attorney.

- b. Within 60 days from the date a request for arbitration is received by the City, the City shall inform Vendor whether it agrees to arbitrate. If the City does not consent, Vendor may proceed with an action in a court of competent jurisdiction in Genesee County, Michigan. If the City does consent, then within 30 days of the consent each party shall submit to the other the name of one person to serve as an arbitrator. The two arbitrators together shall then select a third person. The three together shall then serve as a panel in all proceedings. Any unanimous decision of the three arbitrators shall be a final binding decision. The City's failure to respond to a timely, conforming request for arbitration is deemed consent to arbitration.
 - c. The costs of the arbitration shall be split and borne equally between the parties and such costs are not subject to shifting by the arbitrator.
 - d. Vendor's failure to comply with any portion (including timeliness) of this provision shall be deemed a permanent waiver and forfeiture of the claim, dispute, or question.
 - e. This provision shall survive the expiration or termination of this Agreement in perpetuity.
 - f. Any and all arbitration shall be conducted in Genesee County, Michigan.
8. **Contractual Relationship with Subcontractors:** Nothing contained in this Agreement shall be construed as to automatically create any contractual relationship between the City and any subcontractor or sub-subcontractor of Vendor. And even if subcontractor work is permitted by the City, no subcontract work shall be started prior to the written approval of the subcontractor by the City. The City reserves the right to accept or reject any subcontractor.
9. **City Income Tax Withholding:** Vendor and any subcontractor engaged in this contract shall withhold from each payment to its employees the City income tax on all of their compensation subject to City tax, after giving effect to exemptions. Such withholding shall be at a rate equal to 1% of all compensation paid to the employee who is a resident of the City of Flint, and ½% of the compensation paid to the employee who is a non-resident of the City of Flint. These taxes shall be held in trust and paid over to the City of Flint in accordance with City ordinances and State law. Any failure to do so shall constitute a material breach of this contract.
10. **Insurance/Worker's Compensation:** Vendor shall not commence work under this contract until he has procured and provided evidence of the insurance required under this section. All coverage shall be obtained from insurance companies licensed and authorized to do business in the State of Michigan unless otherwise approved by the City's Finance Department. Policies shall be reviewed by the City's Finance Department for completeness and limits of coverage. All coverage shall be with insurance carriers acceptable to the City of Flint. Vendor shall maintain the following insurance coverage for the duration of the contract:
- a. Commercial General Liability coverage of not less than one million dollars (\$1,000,000) combined single limit with the City of Flint, and including all elected and appointed officials, all employees and volunteers, all boards, commissions and/or authorities and their board members, employees, and volunteers, named as "Additional Insureds." This coverage shall be written on an ISO occurrence basis form and shall include Bodily Injury, Personal Injury, Property Damage, Contractual Liability, Products and Completed Operations, Independent Contractors; Broad Form Commercial General Liability Endorsement, (XCU) Exclusions deleted and a per contract aggregate coverage. This coverage shall be primary to the Additional Insureds and not contributing with any other insurance or similar protection available to the Additional Insureds, whether said other available coverage be primary, contributing, or excess.
 - b. Workers Compensation Insurance, if not a sole proprietor, in accordance with Michigan statutory requirements, including Employers Liability coverage.

- c. Commercial Automobile Insurance in the amount of not less than \$1,000,000 combined single limit per accident with the City of Flint and including all elected and appointed officials, all employees and volunteers, all boards, commissions and/or authorities and their board members, employees, and volunteers, named as “Additional Insureds.” This coverage shall be written on ISO business auto forms covering Automobile Liability, code “any auto.”

Vendor shall furnish the City with two certificates of insurance for all coverage requested with original endorsements for those policies requiring the Additional Insureds. All certificates of insurance must provide the City of Flint with not less than thirty (30) days advance written notice in the event of cancellation, non-payment of premium, non-renewal, or any material change in policy coverage. In addition, the wording “Endeavor to” and “but failure to mail such notice shall impose no obligation or liability of any kind upon the Vendor, its agents or representatives” must be removed from the standard ACORD cancellation statement.

- d. These certificates must identify the City of Flint, Finance Department, as the “Certificate Holder.” Vendor must provide, upon request, certified Vendor of all insurance policies. If any of the above policies are due to expire during the term of this contract, Vendor shall deliver renewal certificates and copies of the new policies to the City of Flint at least ten days prior to the expiration date. Vendor shall ensure that all subcontractors utilized obtain and maintain all insurance coverage required by this provision.

- 11. Certification, Licensing, Debarment, Suspension and Other Responsibilities:** Vendor warrants and certifies that Vendor and/or any of its principals are properly certified and licensed to perform the duties required by this Agreement in accord with laws, rules, and regulations, and is not presently debarred, suspended, proposed for debarment or declared ineligible for the award of any Federal contracts by any Federal agency. Should it be determined that Vendor performed work under this Agreement while in non-compliance with this provision, Vendor agrees to reimburse the City for any costs that the City must repay to any and all entities.
- 12. Force Majeure:** Neither party shall be responsible for damages or delays caused by Force Majeure or other events beyond the control of the other party, and which could not reasonably have been anticipated or prevented. For purposes of this Agreement, Force Majeure includes, but is not limited to, adverse weather conditions, floods, epidemics or pandemics, war, riot, strikes, lockouts, and other industrial disturbances; unknown site conditions, accidents, sabotage, fire, and acts of God. Should Force Majeure occur, the parties shall mutually agree on the terms and conditions upon which the services may continue within seven days of the discovery of the event.
- 13. Good Standing:** Vendor must remain current and not be in default of any obligations due to the City, including the payment of taxes, water & sewer costs, fines, penalties, licenses, or other monies. Violations of this clause shall constitute a substantial and material breach of this Agreement, which shall constitute good cause for the termination of this Agreement.
- 14. Indemnification:** To the fullest extent permitted by law, Vendor agrees to defend, pay on behalf of, indemnify, and hold harmless the City, its elected and appointed officials, employees and volunteers against any and all claims, demands, suits, or losses, including all costs connected therewith, and for any damages which may be asserted, claimed, or recovered against or from the City, its elected and appointed officials, employees, volunteers or others working on behalf of the City, arising out of or related to Vendor’s performance of the Agreement. Should Vendor fail to indemnify the City in the above-mentioned circumstances, the City may exercise its option to deduct the cost that it incurs from any payments due under this Agreement or may file an action in a court of competent jurisdiction, the costs of which shall be paid by Vendor. This provision shall survive the termination and/or expiration of this agreement in perpetuity.

15. **Laws and Ordinances:** Vendor shall obey and abide by all of the laws, rules and regulations of the United States, State of Michigan, Genesee County and the City of Flint during the performance of this agreement. Additionally, should Vendor violate Federal and/or State criminal law involving fraud, bribery, or gratuity violations potentially affecting the Agreement, they should disclose such to the City upon notice of these violations.
16. **Modifications:** Any modifications to this Agreement must be in writing and signed by the Parties or the authorized employee, officer, board or council representative of the parties authorized to make such contractual modifications under State law and local ordinances.
17. **No Third-Party Beneficiary:** This Agreement is for the sole benefit of the parties and their respective successors, and nothing in this Agreement, express or implied, is intended to or shall confer on any other person or entity any legal or equitable right, benefit or remedy of any nature whatsoever under or by reason of this Agreement.
18. **Non-Assignability:** Vendor shall not assign or transfer any interest in this Agreement without the prior written consent of the City.
19. **Non-Disclosure/Confidentiality:** Vendor agrees that it will not disclose any such information provided to Vendor in furtherance of this Agreement, or in any other way make such documents public, without the express written approval of the City or the order of a court of competent jurisdiction.
20. **Non-Discrimination:** Vendor shall comply with the Elliott Larsen Civil Rights Act, 1976 PA 453, as amended, the Persons with Disabilities Civil Rights Act, 1976 PA 220, as amended, and all other federal, state, and local laws relating to nondiscrimination. Vendor shall not discriminate against any employee or applicant for employment with respect to his or her hire, tenure, terms, conditions, or privileges of employment, or any matter directly or indirectly related to employment, because of his or her race, religion, color, national origin, age, sex, height, weight, marital status, association with the federal government, or physical or mental disability that is unrelated to the individual's ability to perform the duties of a particular job or position or status with respect to public assistance. A breach of this covenant is a material breach of this Agreement.
21. **Anti-Lobbying:** Vendor shall not use any of the grant funds awarded in this Agreement for the purpose of lobbying as defined in the State of Michigan's lobbying statute, MCL 4.415(2) or for the purpose of litigation against the State or City.
22. **Ethics:** Pursuant to the Flint City Charter §1-602 (I), every public servant, volunteer and city contractor is to receive training and be provided with a copy of the ethical standards set forth in §1-602 of the Charter. Therefore, Vendor acknowledges receipt of Flint City Charter §1-602 and agrees that Vendor and its staff shall abide by the terms therein and participate in any training provided by the City as may be necessary from time to time.
23. **Notices:** Notices to the City of Flint shall be deemed sufficient if in writing and mailed, postage prepaid, addressed to the **(Davina Donahue and City Clerk, City of Flint, 1101 S. Saginaw Street, Flint, Michigan 48502)**, or to such other address as may be designated in writing by the City from time to time. Notices to Vendor shall be deemed sufficient if in writing and mailed, postage prepaid, addressed to: Black Out Construction, LLC. ATTN: Alex Bronson blackoutpaint@gmail.com (898) 494-7581 34 Queen St. Mount Clemens MI 48043) or to such other address as may be designated in writing by Vendor from time to time.
24. **Records Property of City:** All documents, information, reports and the like prepared or generated by Vendor as a result of this Agreement shall become the sole property of the City and shall be disclosed to the City, or its authorized representatives, upon request.

- 25. Severability:** If any terms of this Agreement or the application of them to any person or circumstance are determined to be null and void, ineffectual, invalid or unenforceable by any competent tribunal, the remaining terms or the application of the terms to persons or circumstances other than to those which were determined to be invalid or unenforceable shall not be affected and shall continue in full force and effect.
- 26. Termination:** This Agreement may be terminated by either party hereto by submitting a notice of termination to the other party. The City, through its City Administrator, may terminate this agreement upon actual notice to Vendor. Vendor may terminate this agreement by providing written notice that shall be effective fourteen (14) days from the date it is submitted unless otherwise agreed to by the parties hereto. Vendor, upon receiving such notice and prorated payment upon termination of this Agreement shall give to the City all pertinent records, data, and information created up to the date of termination to which the City, under the terms of this Agreement, is entitled.
- 27. Time of Performance:** Vendor's services shall commence immediately upon receipt of the notice to proceed and shall be carried out forthwith and without unreasonable delay.
- 28. Union Compliance:** Vendor agrees to comply with all regulations and requirements of any national or local union(s) that may have jurisdiction over any of the materials, facilities, services, or personnel to be furnished by the City. However, this provision does not apply if its application would violate Public Act 98 of 2011.
- 29. Waiver:** Failure of the City to insist upon strict compliance with any of the terms, covenants, or conditions of this Agreement shall not be deemed a waiver of any term, covenant, or condition. Any waiver or relinquishment of any right or power hereunder at any one or more times shall not be deemed a waiver or relinquishment of that right or power at any other time.
- 30. Electronic Signatures:** This Agreement may be signed by the parties hereto by means of electronic signature, utilizing Adobe Acrobat or a like program with similar security features.
- 31. Effective Date:** This Agreement shall be effective June 2nd, 2026.
- 32. Venue:** The Parties consent to venue in Genesee County courts should any action be brought to enforce the terms of this Agreement.
- 33. Whole Agreement:** This Agreement and the documents cited herein contain the entire understanding between and among the parties concerning these matters and supersedes any prior understandings and agreements between and among them respecting the subject matter of this Agreement.

[SIGNATURES ON NEXT PAGE]

Black Out Construction, LLC:

By: _____

_____ **Date**

Its: _____

CITY OF FLINT, a Michigan Municipal Corp.:

Clyde D. Edwards City Administrator

_____ **Date**

Mayor Sheldon Neeley

_____ **Date**

APPROVED AS TO FORM:

JoAnne Gurley, City Attorney

_____ **Date**

EXHIBIT A



❖ EXHIBIT A - SUBMITTAL WITH DETAILED SUMMARY OF PRICING

SCOPE OF WORK ATTACHED SEPARATELY.

1. Failure to use this bid form shall result in bid disqualification.
2. Failure to bid on all items shall result in an "incomplete bid" determination.
3. List value-added considerations on a separate sheet of paper.
4. All bid pricing to include shipping and freight charges.

THIS PAGE MUST BE COMPLETED AND INCLUDED WITH THE BID

The undersigned hereby certifies, on behalf of the respondent named in this Certification (the "Respondent"), that the information provided in this offer submitted to the City of Flint, Department of Purchase and Supplies is accurate and complete, and that I am duly authorized to submit same. I hereby certify that the Respondent has reviewed all documents and requirements included in this offer and accept its terms and conditions.

Terms: Accepted

Fed. ID #: 85-2475065

Company (Respondent): Blackout Construction LLC

Address: 34 Queen St.

City, State & Zip Code: Mount Clemens, MI, 48043

Phone / Fax Number: 989-494-7581 FAX: _____

Email: blackoutpaint@gmail.com

Print Name and Title: Alex Bronson, Owner
(Authorized Representative)

Signed: Alex Bronson
(Authorized Representative)

EXHIBIT B - QUALIFICATIONS AND LICENSES REQUIREMENTS

Please give a synopsis of your qualifications and experience with this service:

My company has been doing full remodels on homes since 2012 with hundreds of satisfied customers. We offer every facet of full home construction and have licensed employees doing all of our home remodeling work.

Please list Licenses:

Residential Bulder's License
Real Estate Brokerage License
Lead Abatement Supervisor's Certificate
OSHA 10 Certificate

How long have you been in business?

14 years

Have you done business with the City of Flint?

Not yet, but looking forward to starting work with the city. We have done plenty of work for residential customers in the city.

If yes, please state the project name.

N/A

EXHIBIT C – DISCLOSURE OF SUPPLIER RESPONSIBILITY STATEMENT

1. List any convictions of any person, subsidiary, or affiliate of the company, arising out of obtaining, or attempting to obtain a public or private contract, or subcontract, or in the performance of such contract or subcontract.

N/A

2. List any convictions of any person, subsidiary, or affiliate of this company for offenses such as embezzlement, theft, fraudulent schemes, etc. or any other offense indicating a lack of business integrity or business honesty which affect the responsibility of the contractor.

N/A

3. List any convictions or civil judgments under state or federal antitrust statutes.

N/A

4. List any violations of contract provisions such as knowingly (without good cause) to perform, or unsatisfactory performance, in accordance with the specifications of a contract.

N/A

5. List any prior suspensions or debarments by any government agency.

N/A

6. List any contracts not completed on time.

N/A

7. List any documented violations of federal or state labor laws, regulations or standards, or occupational safety and health rules.

N/A

**❖ EXHIBIT D – LIST OF REFERENCES: (3) SIMILAR SCOPE OF WORK FROM
THE LAST 5 YEARS**

Providing the following contact information enables the City of Flint to contact those accounts as references.

Reference #1:

Company/Municipality: Eastside Kitchen and Bath
Contact Person: Eric Cords Title: Co-Owner
Address: 22421 Kelly Rd
City: Eastpointe State: MI Zip: 48021
Telephone: 586-775-3700 Fax: N/A
Email: eastsidekitchenandbath@gmail.com
Type of Project: Full bathroom and kitchen remodeling

Project Timeline (Dates): Jun-July 2025 Budget: \$120,000

Reference #2:

Company/Municipality: Ventura
Contact Person: Bill Bramble Title: Owner
Address: 16580 Ventura Cir
City: Clinton Township State: MI Zip: 48038
Telephone: 248-568-5149 Fax: N/A
Email: bramfam@att.net
Type of Project: Full basement finishing with new bathroom built in basement with underground plumbing work.

Project Timeline (Dates): Dec 2025-Feb 2026 Budget: \$60,000

❖ EXHIBIT D – LIST OF REFERENCES: (3) SIMILAR SCOPE OF WORK FROM
THE LAST 5 YEARS (CONTINUES)

Reference #3:

Company/Municipality: Kingsmill

Contact Person: Farris James

Title: Liason

Address: 5754 Kingsmill Dr

City: Bloomfield Hills

State: MI

Zip: 48301

Telephone: 313-569-8866

Fax: N/A

Email: f.firstchoice@yahoo.com

Type of Project: Full exterior remodeling with custom masonry and finish carpentry work

Project Timeline (Dates): Jul-Nov 2026

Budget: \$130,000

❖ EXHIBIT E – CERTIFICATE OF INSURANCE

INSURANCE REQUIREMENTS

The Contractor shall notify all insurance agents and companies retained by the Contractor that these insurance requirements shall be included in any Agreement between the Contractor and the City of Flint.

The Contractor shall purchase and maintain, at its sole expense and as long as it is providing services to the City, the following insurance coverage:

Commercial General Liability - Occurrence form, including coverage for bodily injury, personal injury, property damage (broad form), premises/operations, blanket contractual, and products/completed operations. Coverage shall be endorsed to include the City as an additional insured for work performed by the Contractor in accordance with the Agreement.

Minimum Limits:

- \$1,000,000 per occurrence/\$2,000,000 general aggregate
- \$2,000,000 aggregate for products and completed operations
- \$1,000,000 personal and advertising injury

Automobile - Michigan "no-fault" coverage, and residual automobile liability, comprehensive form, covering owned, hired, and non-owned automobiles. Coverage shall be endorsed to include the City as an additional insured for work performed by the Contractor in accordance with the Agreement.

Minimum Limits:

- No-fault coverages - statutory
- \$500,000 per person/\$1,000,000 per accident - bodily injury
- \$500,000 per occurrence - property damage
- A combined single limit of \$1,000,000 per occurrence

Workers' Compensation and Employer's Liability- Statutory coverage or proof acceptable to the City of approval as a self-insurer by the State of Michigan.

❖ **EXHIBIT E – CERTIFICATE OF INSURANCE (CONTINUES)**

Minimum Limits:

- Workers' Compensation - statutory
- Employer's Liability - \$100,000 each accident/\$100,000 disease - each employee
- \$500,000 disease - policy limit

Professional Liability – Covering acts, errors or omissions of a professional nature committed or alleged to have been committed by the Contractor or any of its subcontractors. Coverage shall be effective upon the date of the Agreement and shall remain effective for a period of three (3) years after the date of final payment thereunder. Such coverage shall be endorsed to include any subcontractors hired by the City.

Minimum Limits:

- \$1,000,000 per occurrence, \$1,000,000 annual aggregate

Insurance coverage shall cover all claims against the City of Flint, its officials and employees, arising out of the work performed by the Contractor or any subcontractors under the Agreement. Should any work be subcontracted, it shall be the responsibility of the Contractor to maintain Independent Contractor's Protective Liability Insurance with limits equal to those specified above for Commercial General Liability Insurance. In addition, the Contractor shall provide proof of Workers' Compensation Insurance for all subcontractors in compliance with the required statutory limits of the State of Michigan.

Said policies of insurance shall be with companies licensed to do business in the State of Michigan and in a form satisfactory to the City. All insurance companies must maintain a rating of B+, VIII or better from AM. Best Company. Certificates of insurance with a thirty (30) day cancellation clause shall be filed with and approved by the City at least five (5) days in advance of commencing work under the Agreement. Cancellation, material restriction, non-renewal or lapse of any of the required policies shall be grounds for immediate termination of the Agreement by the City.

The City reserves the right to request a complete certified copy of the policies for the above coverage's.

Any reduction or exhaustion in the limits of required insurance coverage shall not be deemed to limit the indemnification afforded in accordance with the Agreement or any amendments thereto.

Depending on the subject matter of the transaction, the City may require other insurance coverage in addition to the coverage's contained herein.

THE BID NUMBER IS TO APPEAR ON ALL INSURANCE CERTIFICATES

❖ EXHIBIT F – NON-BIDDER'S RESPONSE

VENDOR'S NAME: _____

NON-BIDDER'S RESPONSE

For the purpose of facilitating your firm's response to our invitation to bid, the City of Flint is interested in ascertaining reasons for prospective bidder's failure to respond to "Invitations to Bid". If your firm is not responding to this bid, please indicate the reason(s) by checking any appropriate item(s) below and return this form to the above address.

We are *not* responding to this "Invitation to Bid" for the following reason(s):

_____ Items or materials requested not manufactured by us or not available to our company.

_____ Our items and/or materials do not meet specifications.

_____ Specifications not clearly understood or applicable (too vague, too rigid, etc.).

_____ Quantities too Small.

_____ Insufficient time allowed for preparation of bid.

_____ Incorrect address used. Our correct mailing address is:

_____ Our branch / division handles this type of bid. We have forwarded this bid on to them but for the future the correct name and mailing address is: _____

_____ **OTHER:** _____

Thank you for your participation in this bid.

❖ EXHIBIT G – CITY OF FLINT AFFADAVIT

AFFIDAVIT FOR INDIVIDUAL

STATE OF _____

S.S.

COUNTY OF _____

_____ being duly sworn,
deposes and says that they are the person making the above bid; and that said bid is genuine and not sham or
collusive, and is not made in the interest of or on behalf of any person not therein named, and that they have not
directly or indirectly induced or solicited any bidder to put in a sham bid; that they have not directly or indirectly
induced or solicited any other person or corporation to refrain from bidding, and that they have not in any manner
sought by collusion to secure themselves any advantage over other bidders.

Subscribed and sworn to before me at _____, in said County and State,

this _____ day of _____, A.D. 20_____

*Notary Public, _____ County, _____

My Commission expires _____, 20_____

QUESTIONS

Is your company able to comply with the deadline of August 28th?

How many employees do you have that will be responsible for the work?

Please provide a timeline for completion of the work, keeping in mind the Bid will be closed May 4th, and all construction must be finished by August 28th?

BID SHEET

PROPERTY #1	\$ 10,571
PROPERTY #2	\$ 9676
PROPERTY #3	\$ 14,673
PROPERTY #4	\$ 16,580
PROPERTY #5	\$ 18,893
PROPERTY #6	\$ 2500
PROPERTY #7	\$ 12,953
PROPERTY #8	\$ 7220
PROPERTY #9	\$ 8288
PROPERTY #10	\$ 15,150
PROPERTY #11	\$ 16,790
PROPERTY #12	\$ 10,148
PROPERTY #13	\$ 5141.50
PROPERTY #14	\$ 12,020
PROPERTY #15	\$ 13,238
PROPERTY #16	\$ 14,470
PROPERTY #17	\$ 7038
PROPERTY #18	\$ 38,700
PROPERTY #19	\$ 4138

GRAND

TOTAL \$ 238,187.50

*All applicants should expect that applications will be subject to review by City of Flint staff and appointed advisory committee. All applications should meet Michigan requirements.

QUESTIONS

Is your company able to comply with the deadline of August 28th?

How many employees do you have that will be responsible for the work?

Please provide a timeline for completion of the work, keeping in mind the Bid will be closed May 5th, and all construction must be finished by August 28th?

Yes we can absolutely get all of these properties done by the August 28th deadline. We currently employ 11 full-time workers and 5 part-time workers. I would be assigning 6 employees specifically to do the jobs outlined in this proposal. Most of these jobs would take about a week because they are small and I would be able to move them around easily to go from plumbing, to floors, to carpentry, and so on. A few would take a couple weeks on the list, but I would also be doing 2-3 homes simultaneously to make sure we meet the deadline. Decks and ramps can be done on one property while concrete work is done on another and bathrooms at a separate property to work in tandem.



Specs By Location

3/5/2026

Address: REDACTED 1 **Unit: Unit 01**

Location: 1 - General Requirements **Approx. Wall SF: 0** **Ceiling/Floor SF: 0**

Spec #	Spec	Quantity	Units	Unit Price	Total Price
Trade: 1 General Requirements					
1	36 BUILDING PERMIT REQUIRED The contractor is responsible for submitting this owner-prepared work write up to the building department, applying for, paying for and receiving a building permit prior to starting any work. Contractor will also be responsible for coordinating a final inspection by the local building department.	1.00	EA	\$500	\$500
2	37 ELECTRICAL PERMIT REQUIRED Prior to the start of work, the contractor shall create any documentation necessary to apply for, pay for and receive an electrical permit on behalf of the owner.	1.00	EA	\$500	\$500
3	38 PLUMBING PERMIT REQUIRED Prior to the start of work, the contractor shall, if necessary: create a riser diagram, septic layout and all other documentation needed to apply for, pay for and receive a plumbing permit on behalf of the owner.	1.00	EA	\$500	\$500
Location Total:					<u>\$1500</u>

Location: 2 - Exterior **Approx. Wall SF: 0** **Ceiling/Floor SF: 0**

Spec #	Spec	Quantity	Units	Unit Price	Total Price
Trade: 10 Carpentry					
4	3470 POST-4"X 4" Remove soffit from East end of porch and save for reinstallation. Support porch roof and remove damaged post at East end of porch. Install 4"x 4" preservative treated post. Reinstall soffit where removed.	1.00	EA	\$250	\$250
5	3580 LOW-RISE STAIR SYSTEM Remove steps at front entry. Replace with low rise treated stair system with handrails on both sides. Stairs to have a 11" minimum run, and 7" maximum rise.	1.00	EA	\$500	\$500
6	9697 EXTERIOR- REPLACE RAILING SYSTEM Remove existing porch railing. Install a 36" high wood railing with 1" x 1" pickets, 3" on center supported by preservative treated 4" x 4". Include closing off each end of porch.	21.00	LF	\$11	\$231
Location Total:					<u>\$981</u>

Address: REDACTED 1 Unit: Unit 01

Location: 3 - Bathroom Approx. Wall SF: 0 Ceiling/Floor SF: 0

Spec #	Spec	Quantity	Units	Unit Price	Total Price
--------	------	----------	-------	------------	-------------

Trade: 1 General Requirements

7	2855	TERMINATE WINDOW	1.00	EA	\$1100	\$1100
<p>Remove Window, repair tearout to match existing. Install R-19, foil faced, roll, fiberglass insulation in crevice. Vapor barrier must face heated space. Use strong wire, "tiger teeth" or mesh to hold insulation in place.</p>						

Trade: 10 Carpentry

8	5909	VINYL PLANK FLOORING -- INSTALL	30.00	SF	\$8	\$240
<p>Remove existing flooring. Install new vinyl plank flooring in owner's choice of color from in-stock options. New vinyl plank floor will be 100% waterproof- Home Depot Home Decorators style vinyl plank flooring or approved equal 4.2 mm thickness or greater. Include all transition pieces at hallways, base trim, and stair nosing covers.</p>						

It is homeowners' responsibility to move furniture and obstacles to allow for contractor installation. Contractor must coordinate this installation with homeowner

Trade: 22 Plumbing

9	6901	VANITY--30" COMPLETE	1.00	EA	\$900	\$900
<p>Remove existing vanity. Install a 30" plywood vanity; including top with backsplash, wash bowl and single lever brass bodied chrome faucet with a maximum 1.5 GPM flow rate. Include PVC drain attached to a code legal plumbing vent, use type L copper or PEX supply piping with brass bodied stops on all supply lines. Seal all penetration through the floor, walls and cabinet for plumbing connections using expanding foam or caulk and cover with chrome escucion plates. Cabinets must comply with California 93120 (formaldehyde content) or all exposed edges must be sealed with a low-VOC sealant.</p>						

10	7011	COMMODO--ACCESSIBLE	1.00	EA	\$450	\$450
<p>Install a 2 piece, close coupled, white, vitreous china, comfort height commode with a maximum water usage per flush of 1.6 Gallons. Include plastic or pressed wood white seat, supply pipe, shut-off valve, flap valve and wax seal. Use 14" rough-in when replacing wall hung commode, and 12" rough-in to replace close coupled commode.</p>						

11	7290	SHOWER--ACCESSIBLE	1.00	EA	\$4000	\$4000
<p>Remove existing tub and surround. Install a STERLING Accord Shower Stall or equal to fit existing opening. Floor shall be non-slip with a maximum 4" lip at entrance. Include hinged seat 19" off floor or provide removable seat, depending on availability on selected model. Include 2 1-1/2" outside diameter grab bars*. A single lever control valve shall feed a fixed shower head and a hand held shower with 5' of stainless steel wrapped hose, through a single lever diversion valve.</p>						

*It is the contractor's responsibility to coordinate with homeowner on grab bar positioning. Determine positioning prior to purchasing shower unit to ensure if a grab bar within the shower is necessary and if available models accommodate

Address: REDACTED 1 **Unit: Unit 01**

Location: 3 - Bathroom **Approx. Wall SF: 0** **Ceiling/Floor SF: 0**

Spec # Spec **Quantity Units Unit Price Total Price**

Trade: 22 Plumbing

that positioning.

Trade: 23 Electric

12 7819 **BATH VENT FAN/LIGHT FIXTURE--NEW--ENERGY STAR** 1.00 EA \$1300 \$1300

Install an ENERGY STAR approved ceiling mounted Fan/Light fixture, such as the Panasonic Wisper Green with an internal damper, and vented to the exterior. The fixture must accommodate Switch fan & light using a single switch with a time delay for the fan such as the EFI Fan/Light Time Delay Switch or equipped with a humidistat sensor. Insulate the ductwork with vinyl or foil faced R 8 minimum duct insulation. Insure proper ventallation to exterior. Include power and switch wiring using #14 copper Romex. Repair any tear out.

Location Total: \$7990

Location: 4 - Basement **Approx. Wall SF: 0** **Ceiling/Floor SF: 0**

Spec # Spec **Quantity Units Unit Price Total Price**

Trade: 10 Carpentry

13 2520 **HANDRAIL--REPLACE INTERIOR** 10.00 LF \$10 \$100

On left side of steps to basement, install 2" round hardwood handrail to code, screwed to metal handrail braces that are attached to studs with screws that enter the framing at least 1 inch, or if fastening to a masonry wall use minimum 3/8 inch diameter plastic masonry plug fasteners and compatible screws. All edges will be eased to a smooth and rounded condition.

Location Total: \$100

Unit Total for REDACTED 1 : \$10,571

Address Grand Total for REDACTED 1: \$10,571

Bidder: Blackout Construction LLC



Specs By Location

3/2/2026

Address: REDACTED 2 **Unit: Unit 01**

Location: 1 - General Requirements **Approx. Wall SF: 0** **Ceiling/Floor SF: 0**

Spec #	Spec	Quantity	Units	Unit Price	Total Price
--------	------	----------	-------	------------	-------------

Trade: 1 **General Requirements**

1	36	BUILDING PERMIT REQUIRED The contractor is responsible for submitting this owner-prepared work write up to the building department, applying for, paying for and receiving a building permit prior to starting any work. Contractor will also be responsible for coordinating a final inspection by the local building building department.	1.00	EA	\$500	\$500
---	----	---	------	----	-------	-------

Trade: 5 **Demolition & Disposal**

2	800	DUMPSTER--20 CUBIC YARDS After procuring all required permits, place a 20 cubic yard, roll-off dumpster or equivalent disposal method without damaging the site. Collect construction debris using dust control methods.	1.00	EA	\$500	\$500
---	-----	--	------	----	-------	-------

Location Total: \$1000

Location: 2 - Exterior **Approx. Wall SF: 0** **Ceiling/Floor SF: 0**

Spec #	Spec	Quantity	Units	Unit Price	Total Price
--------	------	----------	-------	------------	-------------

Trade: 10 **Carpentry**

3	3975	WHEELCHAIR RAMP Remove existing steps, ramp, and trees/shrubs from front porch. Design and construct a preservative treated wood wheelchair ramp complete with 2"x4" safety handrails and non-slip 3/4" plywood surface treatment supported by 4"x4" post set 36" in ground, in conformance with ANSI recommendations. Slope shall not exceed 1"0" rise to 12"0"run. Minimum inside width, 36" Submit preliminary drawing to owner for approval.	276.00	SF	\$30	\$8280
---	------	--	--------	----	------	--------

4	9697	EXTERIOR-- REPLACE RAILING SYSTEM Remove existing porch railing. Install a 36" high wood railing with 1" x 1" pickets, 3" on center supported by preservative treated 4" x 4".	36.00	LF	\$11	\$396
---	------	--	-------	----	------	-------

Location Total: \$8676

Unit Total for REDACTED 2 : \$9676

Address Grand Total for REDACTED 2: \$9676

Bidder: Blackout Construction LLC



Specs By Location

3/3/2026

Address: REDACTED 3		Unit: Unit 01				
Location: 1 - General Requirements		Approx. Wall SF: 0	Ceiling/Floor SF: 0			
Spec #	Spec	Quantity	Units	Unit Price	Total Price	
Trade: 1 General Requirements						
1	38 PLUMBING PERMIT REQUIRED Prior to the start of work, the contractor shall, if necessary: create a riser diagram, septic layout and all other documentation needed to apply for, pay for and receive a plumbing permit on behalf of the owner.	1.00	EA	\$500	\$500	
Location Total:					\$500	
Location: 2 - Bathroom		Approx. Wall SF: 0	Ceiling/Floor SF: 0			
Spec #	Spec	Quantity	Units	Unit Price	Total Price	
Trade: 1 General Requirements						
2	6944 BATHTUB--FIBERGLASS COMPLETE Remove existing tub and surround. Install a white fiberglass tub to fit opening complete with lever operated pop up drain and overflow, PVC waste, single lever shower diverter and Delta 58499 or equivalent two-in-one shower head. Include 2 1-1/2" outside diameter grab bars" *It is the contractor's responsibility to coordinate with homeowner on grab bar positioning. Determine positioning prior to purchasing shower unit to ensure if a grab bar within the shower is necessary and if available models accommodate that positioning.	1.00	AL	\$3800	\$3800	
Trade: 10 Carpentry						
3	2312 SUBFLOOR--3/4" Install 3/4" tongue and groove CDX plywood decking nailed 8" on center using screw shank or cement coated nails.	54.00	SF	\$2.50	\$135	
4	5909 VINYL PLANK FLOORING -- INSTALL Remove existing flooring. Install new vinyl plank flooring in owner's choice of color from in-stock options. New vinyl plank floor will be 100% waterproof- Home Depot Home Decorators style vinyl plank flooring or approved equal 4.2 mm thickness or greater. Include all transition pieces at hallways and base trim.	36.00	SF	\$8	\$288	
Trade: 22 Plumbing						
5	6900 VANITY--24" COMPLETE Remove existing vanity. Install a 24" plywood vanity; including top with backsplash, wash bowl and single lever brass bodied	1.00	EA	\$900	\$900	

Address: REDACTED 3 **Unit: Unit 01**

Location: 2 - Bathroom **Approx. Wall SF: 0** **Ceiling/Floor SF: 0**

Spec #	Spec	Quantity	Units	Unit Price	Total Price
--------	------	----------	-------	------------	-------------

Trade: 22 Plumbing

chrome faucet with a maximum 1.5 GPM flow rate. Include PVC drain attached to a code legal plumbing vent, use type L copper or PEX supply piping with brass bodied stops on all supply lines. Seal all penetration through the floor, walls and cabinet for plumbing connections using expanding foam or caulk and cover with chrome eschucion plates. Cabinets must comply with California 93120 (formaldehyde content) or all exposed edges must be sealed with a low-VOC sealant.

Trade: 23 Electric

6	7820	BATH VENT FAN/LIGHT FIXTURE--ENERGY STAR--REPLACE EXISTING	1.00	EA	\$1300	\$1300
---	------	---	------	----	--------	--------

Remove existing bath vent fan and install an ENERGY STAR approved ceiling mounted Fan/Light fixture, such as the Panasonic Wisper Green with an internal damper, and vented to the exterior. The fixture must accommodate Switch fan & light using a single switch with a time delay for the fan such as the EFI Fan/Light Time Delay Switch or equipped with a humidistat sensor. Ensure proper ventilation to exterior. Insulate the ductwork with vinyl or foil faced R 8 minimum duct insulation. Repair any tear out.

Location Total: \$6423

Location: 3 - Kitchen **Approx. Wall SF: 0** **Ceiling/Floor SF: 0**

Spec #	Spec	Quantity	Units	Unit Price	Total Price
--------	------	----------	-------	------------	-------------

Trade: 10 Carpentry

7	3747	REPLACE COUNTER TOP--PLASTIC LAMINATE	15.00	LF	\$70	\$1050
---	------	--	-------	----	------	--------

Dispose of existing counter top. Field measure for sizing and install new light colored countertop in homeowner's choice of color from in stock options. All particleboard and MDF components must comply with California 93120 (formaldehyde content) or all exposed edges must be sealed with a low-VOC sealant. Screw to base cabinet a square edged plastic laminate counter top. Provide end-caps and cutout for sink. Caulk countertop to adjoining walls with low VOC caulking to match wall color. Owner's choice of in-stock color and texture.

8	5909	VINYL PLANK FLOORING -- INSTALL	150.00	SF	\$8	\$1200
---	------	--	--------	----	-----	--------

Remove existing flooring throughout kitchen, landing area, and steps to basement. Install new vinyl plank flooring in owner's choice of color from in-stock options. New vinyl plank floor will be 100% waterproof- Home Depot Home Decorators style vinyl plank flooring or approved equal 4.2 mm thickness or greater. Include all transition pieces at hallways, base trim, and stair nosing covers.

It is homeowners' responsibility to move furniture and obstacles to allow for contractor installation. Contractor must coordinate this installation with homeowner

9	Custom	CLOSING HARDWARE -- REPLACE	14.00	EA	\$25	\$350
---	--------	------------------------------------	-------	----	------	-------

Address: REDACTED 3

Unit: Unit 01

Location: 3 - Kitchen

Approx. Wall SF: 0

Ceiling/Floor SF: 0

Spec #	Spec	Quantity	Units	Unit Price	Total Price
--------	------	----------	-------	------------	-------------

Trade: 10 Carpentry

On all cabinet doors, remove existing closing hardware and install new hardware to ensure cabinet doors stay shut when closed. Adjust hinges if necessary for proper functionality.

Trade: 18 Ceramic Tile

10	3748	BACKSPLASH -- REPLACE	15.00	LF	\$40	\$600
----	------	------------------------------	-------	----	------	-------

If existing, remove backsplash material and prepare substrate by cleaning and patching any holes from demolition. Install subway tile or equivalent per square ft. priced back splash material in owners' choice of color from in-stock options provided by contractor. Install backsplash per manufacturer specifications to cover from countertop to underside of cabinets.

Trade: 22 Plumbing

11	6835	SINK--DOUBLE BOWL COMPLETE	1.00	EA	\$900	\$900
----	------	-----------------------------------	------	----	-------	-------

Install a 22 gauge 33" x 22" x 7" double bowl, stainless steel, self rimming kitchen sink including a steel, metal body faucet, rated at 2.0 GPM or less, with a 15 year drip-free warranty, grease trap, supply lines, full port ball type shut-off valves & escutcheon plates on all supply & drain lines. NOTE: All copper is to be soldered (no compression fittings) & all PVC fittings glued.

Location Total: \$4100

Location: 4 - DR, LR, Hall

Approx. Wall SF: 0

Ceiling/Floor SF: 0

Spec #	Spec	Quantity	Units	Unit Price	Total Price
--------	------	----------	-------	------------	-------------

Trade: 10 Carpentry

12	5909	VINYL PLANK FLOORING -- INSTALL	425.00	SF	\$8	\$3400
----	------	--	--------	----	-----	--------

Remove existing flooring throughout kitchen, landing area, and steps to basement. Install new vinyl plank flooring in owner's choice of color from in-stock options. New vinyl plank floor will be 100% waterproof- Home Depot Home Decorators style vinyl plank flooring or approved equal 4.2 mm thickness or greater. Include all transition pieces at hallways, base trim, and stair nosing covers.

It is homeowners' responsibility to move furniture and obstacles to allow for contractor installation. Contractor must coordinate this installation with homeowner

Location Total: \$3400

Location: 5 - Basement

Approx. Wall SF: 0

Ceiling/Floor SF: 0

Spec #	Spec	Quantity	Units	Unit Price	Total Price
--------	------	----------	-------	------------	-------------

Address: REDACTED 3 Unit: Unit 01

Location: 5 - Basement Approx. Wall SF: 0 Ceiling/Floor SF: 0

Spec # Spec Quantity Units Unit Price Total Price

Trade: 1 General Requirements

13 3936 GRAB BAR -- INSTALL 1.00 EA \$150 \$150
Install grab bar in landing at rear entry. Coordinate with homeowner on best placement. Where installation is on frame wall, secure tightly to studs. If studs cannot be located, open the wall, install blocking and repair wall to original condition. Installation must be capable of withstanding stress and weight of a person pulling him/herself up. Grab bars of all stainless steel, 18 gauge, 1-1/4" outside diameter as made by Tubular Specialties Mfs., Inc. or equal.

Trade: 10 Carpentry

14 2520 HANDRAIL--REPLACE INTERIOR 10.00 LF \$10 \$100
Install 2" round hardwood handrail to code, screwed to metal handrail braces that are attached to studs with screws that enter the framing at least 1 inch, or if fastening to a masonry wall use minimum 3/8 inch diameter plastic masonry plug fasteners and compatible screws. All edges will be eased to a smooth and rounded condition.

Location Total: \$250

Unit Total for REDACTED 3 : \$14,673

Address Grand Total for REDACTED 3: \$14,673

Bidder: Blackout Construction LLC



Specs By Location

3/2/2026

Address: REDACTED 4

Unit: Unit 01

Location: 1 - General Requirements

Approx. Wall SF: 0

Ceiling/Floor SF: 0

Trade:	Spec #	Spec	Quantity	Units	Unit Price	Total Price
1	36	BUILDING PERMIT REQUIRED The contractor is responsible for submitting this owner-prepared work write up to the building department, applying for and receiving a building permit prior to starting any work.	1.00	EA	\$500	\$500
2	38	PLUMBING PERMIT REQUIRED Prior to the start of work, the contractor shall, if necessary: create a riser diagram, septic layout and all other documentation needed to apply for, pay for and receive a plumbing permit on behalf of the owner.	1.00	EA	\$500	\$500

Trade: 5 Demolition & Disposal

3	800	DUMPSTER--20 CUBIC YARDS After procuring all required permits, place a 20 cubic yard, roll-off dumpster without damaging the site. Collect construction debris using dust control methods.	1.00	EA	\$500	\$500
---	-----	--	------	----	-------	-------

Location Total: \$1500

Location: 2 - Exterior

Approx. Wall SF: 0

Ceiling/Floor SF: 0

Trade:	Spec #	Spec	Quantity	Units	Unit Price	Total Price
4	3165	DOOR & FRAME--METAL SECURITY Dispose of existing security door at rear entry and field measure and install metal security door to match existing from available in-stock options.	1.00	EA	\$600	\$600
5	3185	DOOR--PREHUNG METAL ENTRANCE At rear of house, Dispose of door and frame. Widen door opening to accommodate a 36" door. Install a prehung metal, insulated, 6-panel entrance door and jamb including interior and exterior casing, peep hole, weatherstripping, interlocking threshold, one entrance and one mortised deadbolt keyed alike. Retrim interior and exterior to match existing as closely as possible.	1.00	EA	\$1100	\$1100
6	3975	WHEELCHAIR RAMP Demolish existing steps and decking at rear of house. Design and construct a preservative treated wood wheelchair ramp complete with 2"x4" safety handrails and non-slip 3/4" plywood	296.00	SF	\$30	\$8880

Address: REDACTED 4 Unit: Unit 01

Location: 2 - Exterior Approx. Wall SF: 0 Ceiling/Floor SF: 0

Spec #	Spec	Quantity	Units	Unit Price	Total Price
--------	------	----------	-------	------------	-------------

Trade: 10 Carpentry

surface treatment supported by 4"x4" post set 36" in ground, in conformance with ANSI recommendations. Slope shall not exceed 1'0" rise to 12'0"run. Minimum inside width, 36" Submit preliminary drawing to owner for approval

Location Total: \$10,580

Location: 3 - Kitchen Approx. Wall SF: 0 Ceiling/Floor SF: 0

Spec #	Spec	Quantity	Units	Unit Price	Total Price
--------	------	----------	-------	------------	-------------

Trade: 10 Carpentry

7	3450 ENTRY -- WIDEN	1.00	EA	\$500	\$500
Between Kitchen and Utility Room, remove existing trim from both sides of door. Cut and reframe opening to 36". Retrim both sides to match existing trim as closely as possible.					

Location Total: \$500

Location: 4 - Bathroom Approx. Wall SF: 0 Ceiling/Floor SF: 0

Spec #	Spec	Quantity	Units	Unit Price	Total Price
--------	------	----------	-------	------------	-------------

Trade: 22 Plumbing

8	7290 SHOWER--ACCESSIBLE	1.00	EA	\$4000	\$4000
Remove existing tub and surround. Install a STERLING Accord Shower Stall or equal to fit existing opening. Floor shall be non-slip with a maximum 4" lip at entrance. Include hinged seat 19" off floor or provide removable seat, depending on availability on selected model. Include 2 1-1/2" outside diameter grab bars*. A single lever control valve shall feed a fixed shower head and a hand held shower with 5' of stainless steel wrapped hose, through a single lever diversion valve.					
*It is the contractor's responsibility to coordinate with homeowner on grab bar positioning. Determine positioning prior to purchasing shower unit to ensure if a grab bar within the shower is necessary and if available models accommodate that positioning.					

Location Total: \$4000

Unit Total for REDACTED 4: \$16,580

Address Grand Total for REDACTED 4: \$16,580

Bidder: Blackout Construction LLC



Specs By Location

3/3/2026

Address: REDACTED 5		Unit: Unit 01			
Location:	1 - Exterior	Approx. Wall SF:	0		
Spec #	Spec	Quantity	Units	Unit Price	Total Price
Trade: 1 General Requirements					
1	Custom ANTISLIP TAPE -- REMOVE & REPLACE Remove existing antislip tape from ramp, porch, and steps. Replace with new 36" antislip tape.	35.00	LF	\$5	\$205
Trade: 6 Concrete & Paving					
2	980 DRIVEWAY--CONCRETE At North side of existing driveway, level surface, prepare a 3" gravel base over a uniformly graded & compacted subgrade. Form and pour 3000 psi air entrained concrete, 4" thick by 10' wide driveway. Provide #10 welded wire mesh, expansion joints at 10' intervals, and a broom finish surface that directs water away from the building. Remove forms. Regrade and seed disturbed areas. **Homeowner is required to combine lots in order to proceed with this modification**	600.00	SF	\$27.50	\$16,500
Trade: 10 Carpentry					
3	2685 AWNING--ALUMINUM Remove gutter from fascia above front entrance. Fabricate and install an enameled aluminum awning securely attached with aluminum screws through fascia to framing and to top rail of porch.	36.00	SF	\$40	\$1440
4	3522 WOOD STAIR HANDRAIL--REPLACE EXT Remove existing handrail and braces. Install preservative treated, code approved grabbable handrail supported by braces along all interior sides of ramp, porch, and steps.	68.00	LF	\$11	\$748
Location Total:					\$18,893
Unit Total for REDACTED 5:					\$18,893
Address Grand Total for REDACTED 5:					\$18,893
Bidder:		Blackout Construction LLC			



Specs By Location

3/3/2026

Address: REDACTED 6 **Unit: Unit 01**

Location: 1 - General Requirements **Approx. Wall SF: 0** **Ceiling/Floor SF: 0**

Spec #	Spec	Quantity	Units	Unit Price	Total Price
Trade: 1 General Requirements					
1 36	BUILDING PERMIT REQUIRED The contractor is responsible for submitting this owner-prepared work write up to the building department, applying for, paying for and receiving a building permit prior to starting any work. Contractor will also be responsible for coordinating a final inspection by the local building department.	1.00	EA	\$500	\$500

Trade: 5 Demolition & Disposal					
2 800	DUMPSTER--20 CUBIC YARDS After procuring all required permits, place a 20 cubic yard, roll-off dumpster or equivalent disposal method without damaging the site. Collect construction debris using dust control methods.	1.00	EA	\$500	\$500
Location Total:					\$1000

Location: 2 - Exterior (Front) **Approx. Wall SF: 0** **Ceiling/Floor SF: 0**

Spec #	Spec	Quantity	Units	Unit Price	Total Price
Trade: 5 Demolition & Disposal					
3 755	DEMO/REBUILD PORCH Demolish entire porch including deck, railing/walls, substructure, and steps and dispose of in code legal dump. Rake yard clean. Replace existing footprint and design with treated lumber to code. Include railing on both sides. Patch trim and siding matching as closely as possible in like kind.	50.00	SF	\$40	\$2000

Trade: 10 Carpentry					
4 3580	LOW-RISE STAIR SYSTEM Construct a low-rise treated stair system with handrail on both sides. Stairs to have a 11" minimum run, and 7" maximum rise.	1.00	EA	\$500	\$500
Location Total:					\$2500

Location: 3 - Exterior (Rear) **Approx. Wall SF: 0** **Ceiling/Floor SF: 0**

Spec #	Spec	Quantity	Units	Unit Price	Total Price
--------	------	----------	-------	------------	-------------

Address: REDACTED 6 **Unit: Unit 01**

Location: 3 - Exterior (Rear) **Approx. Wall SF: 0** **Ceiling/Floor SF: 0**

Spec # Spec Quantity Units Unit Price Total Price

Trade: 10 Carpentry

5	3580	LOW-RISE STAIR SYSTEM Remove steps at rear entry. Replace with low rise treated stair system with handrail on both sides. Stairs to have a 11" minimum run, and 7" maximum rise.	1.00	EA	\$500	\$500
---	------	--	------	----	-------	-------

Location Total: \$500

Unit Total for REDACTED 6 : \$2500

Address Grand Total for REDACTED 6: \$2500

Bidder: Blackout Construction LLC



Specs By Location

3/3/2026

Address: REDACTED 7 **Unit:** Unit 01

Location: 1 - General Requirements **Approx. Wall SF:** 0 **Ceiling/Floor SF:** 0

Spec #	Spec	Quantity	Units	Unit Price	Total Price
--------	------	----------	-------	------------	-------------

Trade: 1 **General Requirements**

1	36	BUILDING PERMIT REQUIRED The contractor is responsible for submitting this owner-prepared work write up to the building department, applying for, paying for and receiving a building permit prior to starting any work. Contractor will also be responsible for coordinating a final inspection by the local building department.	1.00	EA	\$500	\$500
2	37	ELECTRICAL PERMIT REQUIRED Prior to the start of work, the contractor shall create any documentation necessary to apply for, pay for and receive an electrical permit on behalf of the owner.	1.00	EA	\$500	\$500
3	38	PLUMBING PERMIT REQUIRED Prior to the start of work, the contractor shall, if necessary: create a riser diagram, septic layout and all other documentation needed to apply for, pay for and receive a plumbing permit on behalf of the owner.	1.00	EA	\$500	\$500

Trade: 5 **Demolition & Disposal**

4	800	DUMPSTER--20 CUBIC YARDS After procuring all required permits, place a 20 cubic yard, roll-off dumpster or equivalent disposal method without damaging the site. Collect construction debris using dust control methods.	1.00	EA	\$500	\$500
---	-----	--	------	----	-------	-------

Location Total: \$2000

Location: 2 - Exterior **Approx. Wall SF:** 0 **Ceiling/Floor SF:** 0

Spec #	Spec	Quantity	Units	Unit Price	Total Price
--------	------	----------	-------	------------	-------------

Trade: 10 **Carpentry**

5	3975	WHEELCHAIR RAMP Remove steps, railing, and 2 bushes from front entry. Design and construct a preservative treated wood wheelchair ramp complete with 2"x4" safety handrails and non-slip 3/4" plywood surface treatment supported by 4"x4" post set 36" in ground, in conformance with ANSI recommendations. Slope shall not exceed 1'0" rise to 12'0"run. Minimum inside width, 36" Submit preliminary drawing to owner for approval.	176.00	SF	\$30	\$5280
---	------	--	--------	----	------	--------

Address: REDACTED 7

Unit: Unit 01

Location Total: \$5280

Location: 3 - Bathroom

Approx. Wall SF: 0

Ceiling/Floor SF: 0

Spec #	Spec	Quantity	Units	Unit Price	Total Price
Trade: 10	Carpentry				
6	Custom MEDICINE CABINET -- LOWER	1.00	EA	\$850	\$850

Remove medicine cabinet and remove necessary wall tile to reinstall lower on the wall. Coordinate with homeowner on sufficient height for their stature. Reinstall medicine cabinet based on homeowner's preference and use tile from shower walls or what was removed from below the cabinet to repair tearout above, matching pattern as closely as possible.

Trade: 22 Plumbing

7	7290 SHOWER--ACCESSIBLE	1.00	EA	\$4000	\$4000
---	-------------------------	------	----	--------	--------

Remove existing tub and tile necessary to install shower walls*. Install a STERLING Accord Shower Stall or equal to fit existing opening. Floor shall be non-slip with a maximum 4" lip at entrance. Include hinged seat 19" off floor or provide removable seat, depending on availability on selected model. Include 2 1-1/2" outside diameter grab bars*, A single lever control valve shall feed a fixed shower head and a hand held shower with 5' of stainless steel wrapped hose, through a single lever diversion valve.

*It is the contractor's responsibility to coordinate with homeowner on grab bar positioning. Determine positioning prior to purchasing shower unit to ensure if a grab bar within the shower is necessary and if available models accommodate that positioning.

*Save approximately 10 SF of tile to repair tearout on opposite wall.

Trade: 23 Electric

8	7583 REPLACE RECEPTACLE WITH GFCI DEVICE	1.00	EA	\$375	\$375
---	--	------	----	-------	-------

Move electrical box between sink and vanity to the opposite side of the vanity and replace existing receptacle with an surfaced mounted ground fault circuit interrupt receptacle with cover plate. Color to match existing. Use tile saved from shower walls to repair tearout area, matching pattern as closely as possible.

Location Total: \$5225

Location: 4 - Hall

Approx. Wall SF: 0

Ceiling/Floor SF: 0

Spec #	Spec	Quantity	Units	Unit Price	Total Price
Trade: 10	Carpentry				
9	5909 VINYL PLANK FLOORING -- INSTALL	56.00	SF	\$8	\$448

Remove carpet from hallway. Install new vinyl plank flooring in owner's choice of color from in-stock options. New vinyl plank floor will be 100% waterproof- Home Depot Home Decorators style vinyl plank flooring or approved equal 4.2 mm thickness or

Address: REDACTED 7 **Unit: Unit 01**

Location: 4 - Hall **Approx. Wall SF: 0** **Ceiling/Floor SF: 0**

Spec #	Spec	Quantity	Units	Unit Price	Total Price
Trade: 10	Carpentry				

greater. Include all transition pieces at hallways and base trim.

Location Total: \$448

Unit Total for REDACTED 7 : \$12,953

Address Grand Total for REDACTED 7 : \$12,953

Bidder: Blackout Construction LLC



Specs By Location

3/2/2026

Address: REDACTED 8		Unit: Unit 01			
Location:	1 - General Requirements	Approx. Wall SF: 0	Ceiling/Floor SF: 0		
Spec #	Spec	Quantity	Units	Unit Price	Total Price
Trade: 1	General Requirements				
1	38 PLUMBING PERMIT REQUIRED Prior to the start of work, the contractor shall, if necessary: create a riser diagram, septic layout and all other documentation needed to apply for, pay for and receive a plumbing permit on behalf of the owner.	1.00	EA	\$500	\$500
Location Total:					\$500

Location:	2 - Bathroom	Approx. Wall SF: 0	Ceiling/Floor SF: 0		
Spec #	Spec	Quantity	Units	Unit Price	Total Price
Trade: 10	Carpentry				
2	5909 VINYL PLANK FLOORING -- INSTALL Remove existing flooring. Install new vinyl plank flooring in owner's choice of color from in-stock options. New vinyl plank floor will be 100% waterproof- Home Depot Home Decorators style vinyl plank flooring or approved equal 4.2 mm thickness or greater. Include all transition pieces at hallways and base trim.	40.00	SF	\$8	\$320
Trade: 22	Plumbing				
3	7011 COMMODO--ACCESSIBLE Remove existing commode. Install a 2 piece, close coupled, white, vitreous china, comfort height commode with a maximum water usage per flush of 1.6 Gallons. Include plastic or pressed wood white seat, supply pipe, shut-off valve, flap valve and wax seal. Use 14" rough-in when replacing wall hung commode, and 12" rough-in to replace close coupled commode.	1.00	EA	\$450	\$450
4	7290 SHOWER--ACCESSIBLE Remove existing tub and surround. Install a STERLING Accord Shower Stall or equal to fit existing opening. Floor shall be non-slip with a maximum 4" lip at entrance. Include hinged seat 19" off floor or provide removable seat, depending on availability on selected model. Include 2 1-1/2" outside diameter grab bars*, A single lever control valve shall feed a fixed shower head and a hand held shower with 5' of stainless steel wrapped hose, through a single lever diversion valve.	1.00	EA	\$4000	\$4000

*It is the contractor's responsibility to coordinate with homeowner on grab bar positioning. Determine positioning prior to purchasing shower unit to ensure if a grab bar within

Address: REDACTED 8 **Unit: Unit 01**

Location: 2 - Bathroom Approx. Wall SF: 0 Ceiling/Floor SF: 0

Spec #	Spec	Quantity	Units	Unit Price	Total Price
--------	------	----------	-------	------------	-------------

Trade: 22 **Plumbing**
 the shower is necessary and if available models accommodate that positioning.

Trade: 23 **Electric**

5	7820	BATH VENT FAN/LIGHT FIXTURE--ENERGY STAR--REPLACE EXISTING	1.00	EA	\$1300	\$1300
Remove existing bath vent fan and install an ENERGY STAR approved ceiling mounted Fan/Light fixture, such as the Panasonic Wisper Green with an internal damper, and vented to the exterior. The fixture must accommodate Switch fan & light using a single switch with a time delay for the fan such as the EFI Fan/Light Time Delay Switch or equipped with a humidistat sensor. Ensure proper ventilation to exterior. Insulate the ductwork with vinyl or foil faced R 8 minimum duct insulation. Repair any tear out.						

Location Total: \$6070

Location: 3 - Exterior Approx. Wall SF: 0 Ceiling/Floor SF: 0

Spec #	Spec	Quantity	Units	Unit Price	Total Price
--------	------	----------	-------	------------	-------------

Trade: 10 **Carpentry**

6	3580	LOW-RISE STAIR SYSTEM	1.00	EA	\$500	\$500
Remove steps at front porch entry. Replace with low rise treated stair system with handrail on both sides. Stairs to have a 11" minimum run, and 7" maximum rise.						

Location Total: \$500

Location: 4 - Hall Approx. Wall SF: 0 Ceiling/Floor SF: 0

Spec #	Spec	Quantity	Units	Unit Price	Total Price
--------	------	----------	-------	------------	-------------

Trade: 10 **Carpentry**

7	2520	HANDRAIL--INSTALL INTERIOR	15.00	LF	\$10	\$150
Along hallway, install 2" round hardwood handrail to code, screwed to metal handrail braces that are attached to studs with screws that enter the framing at least 1 inch, or if fastening to a masonry wall use minimum 3/8 inch diameter plastic masonry plug fasteners and compatible screws. All edges will be eased to a smooth and rounded condition.						

Location Total: \$150

Unit Total for REDACTED 8: \$7220

Address Grand Total for REDACTED 8: \$7220

Bidder: Blackout Construction LLC



Specs By Location

3/3/2026

Address: REDACTED 9		Unit: Unit 01			
Location: 1 - General Requirements		Approx. Wall SF: 0	Ceiling/Floor SF: 0		
Spec #	Spec	Quantity	Units	Unit Price	Total Price
Trade: 1 General Requirements					
1	37 ELECTRICAL PERMIT REQUIRED Prior to the start of work, the contractor shall create any documentation necessary to apply for, pay for and receive an electrical permit on behalf of the owner.	1.00	EA	\$500	\$500
2	38 PLUMBING PERMIT REQUIRED Prior to the start of work, the contractor shall, if necessary: create a riser diagram, septic layout and all other documentation needed to apply for, pay for and receive a plumbing permit on behalf of the owner.	1.00	EA	\$500	\$500
Location Total:					\$1000
Location: 2 - Bathroom		Approx. Wall SF: 0	Ceiling/Floor SF: 0		
Spec #	Spec	Quantity	Units	Unit Price	Total Price
Trade: 1 General Requirements					
3	2855 TERMINATE WINDOW Remove Window, repair tearout to match existing. Install R-19, foil faced, roll, fiberglass insulation in crevice. Vapor barrier must face heated space. Use strong wire, "tiger teeth" or mesh to hold insulation in place.	1.00	EA	\$1100	\$1100
Trade: 10 Carpentry					
4	5909 VINYL PLANK FLOORING -- INSTALL Over existing flooring, install new vinyl plank flooring in owner's choice of color from in-stock options. New vinyl plank floor will be 100% waterproof- Home Depot Home Decorators style vinyl plank flooring or approved equal 4.2 mm thickness or greater. Include all transition pieces at hallways and base trim.	36.00	SF	\$8	\$288
Trade: 22 Plumbing					
5	7011 COMMODE--ACCESSIBLE Install a 2 piece, close coupled, white, vitreous china, comfort height commode with a maximum water usage per flush of 1.6 Gallons. Include plastic or pressed wood white seat, supply pipe, shut-off valve, flap valve and wax seal. Use 14" rough-in when replacing wall hung commode, and 12" rough-in to replace close coupled commode.	1.00	EA	\$450	\$450
6	7290 SHOWER--ACCESSIBLE	1.00	EA	\$4000	\$4000

Address: REDACTED 9 Unit: Unit 01

Location: 2 - Bathroom Approx. Wall SF: 0 Ceiling/Floor SF: 0

Spec #	Spec	Quantity	Units	Unit Price	Total Price
--------	------	----------	-------	------------	-------------

Trade: 22 Plumbing

Remove existing tub and tile surround. Install a STERLING Accord Shower Stall or equal to fit existing opening. Floor shall be non-slip with a maximum 4" lip at entrance. Include hinged seat 19" off floor or provide removable seat, depending on availability on selected model. Include 2 1-1/2" outside diameter grab bars*, A single lever control valve shall feed a fixed shower head and a hand held shower with 5' of stainless steel wrapped hose, through a single lever diversion valve.

*It is the contractor's responsibility to coordinate with homeowner on grab bar positioning. Determine positioning prior to purchasing shower unit to ensure if a grab bar within the shower is necessary and if available models accommodate that positioning.

Trade: 23 Electric

7	7819	BATH VENT FAN/LIGHT FIXTURE--NEW--ENERGY STAR	1.00	EA	\$1300	\$1300
Install an ENERGY STAR approved ceiling mounted Fan/Light fixture, such as the Panasonic Wisper Green with an internal damper, and vented to the exterior. The fixture must accommodate Switch fan & light using a single switch with a time delay for the fan such as the EFI Fan/Light Time Delay Switch or equipped with a humidistat sensor. Insulate the ductwork with vinyl or foil faced R 8 minimum duct insulation. Insure proper ventallation to exterior. Include power and switch wiring using #14 copper Romex. Repair any tear out.						

Location Total: \$7138

Location: 3 - Basement Approx. Wall SF: 0 Ceiling/Floor SF: 0

Spec #	Spec	Quantity	Units	Unit Price	Total Price
--------	------	----------	-------	------------	-------------

Trade: 23 Electric

8	7423	ELECTRIC PANEL COVER--REPLACE	1.00	EA	\$150	\$150
Reinstall existing electric panel cover.						

Location Total: \$150

Unit Total for REDACTED 9: \$8288

Address Grand Total for REDACTED 9: \$8288

Bidder: Blackout Construction LLC



Specs By Location

3/3/2026

Address: REDACTED 10 **Unit: Unit 01**

Location: 1 - General Requirements **Approx. Wall SF: 0** **Ceiling/Floor SF: 0**

Spec #	Spec	Quantity	Units	Unit Price	Total Price
--------	------	----------	-------	------------	-------------

Trade: 1 General Requirements

1	36	BUILDING PERMIT REQUIRED	1.00	EA	\$500	\$500
<p>The contractor is responsible for submitting this owner-prepared work write up to the building department, applying for, paying for and receiving a building permit prior to starting any work. Contractor will also be responsible for coordinating a final inspection by the local building department.</p>						

2	38	PLUMBING PERMIT REQUIRED	1.00	EA	\$500	\$500
<p>Prior to the start of work, the contractor shall, if necessary: create a riser diagram, septic layout and all other documentation needed to apply for, pay for and receive a plumbing permit on behalf of the owner.</p>						

Trade: 5 Demolition & Disposal

3	800	DUMPSTER--20 CUBIC YARDS	1.00	EA	\$500	\$500
<p>After procuring all required permits, place a 20 cubic yard, roll-off dumpster or equivalent disposal method without damaging the site. Collect construction debris using dust control methods.</p>						

Location Total: \$1500

Location: 2 - Exterior **Approx. Wall SF: 0** **Ceiling/Floor SF: 0**

Spec #	Spec	Quantity	Units	Unit Price	Total Price
--------	------	----------	-------	------------	-------------

Trade: 10 Carpentry

4	3975	WHEELCHAIR RAMP	200.00	SF	\$30	\$6000
<p>Remove railing from North end of porch. Design and construct a preservative treated wood wheelchair ramp complete with 2"x4" safety handrails and non-slip 3/4" plywood surface treatment supported by 4"x4" post set 36" in ground, in conformance with ANSI recommendations. Slope shall not exceed 1'0" rise to 12'0"run. Minimum inside width, 36". Remove 4' section of fencing and top railing at South end of front yard. Install necessary posts, hardware, and gate. Submit preliminary drawing to owner for approval.</p>						

Location Total: \$6000

Address: REDACTED 10 Unit: Unit 01
 Location: 3 - Basement Approx. Wall SF: 0 Ceiling/Floor SF: 0

Spec #	Spec	Quantity	Units	Unit Price	Total Price
Trade: 1 General Requirements					
5	3936 GRAB BAR -- INSTALL At side entry landing, install grab grab bar*. Where installation is on frame wall, secure tightly to studs. If studs cannot be located, open the wall, install blocking and repair wall to original condition. Installation must be capable of withstanding stress and weight of a person pulling him/herself up. Grab bars of all stainless steel, 18 gauge, 1-1/4" outside diameter as made by Tubular Specialties Mfs., Inc. or equal. *Coordinate with homeowner on grab bar placement.	1.00	EA	\$150	\$150
Location Total:					\$150

Location: 4 - Bathroom Approx. Wall SF: 0 Ceiling/Floor SF: 0

Spec #	Spec	Quantity	Units	Unit Price	Total Price
Trade: 10 Carpentry					
6	3450 DOOR -- WIDEN Reframe opening for 32" door. Install prehung flush, hollow core, masonite door to match existing as closely as possible. Include privacy lockset and offset hinges. Cut and remove doorstop below latch bolt opening. Assure remaining door stop is properly positioned and secured to the jam.	1.00	EA	\$500	\$500

Trade: 22 Plumbing

7	7290 SHOWER--ACCESSIBLE Remove existing tub and tile surround. Install a STERLING Accord Shower Stall or equal to fit existing opening. Install subway tile on shower walls in homeowners choice of color based on contractor selection. Floor shall be non-slip with a maximum 4" lip at entrance. Include hinged seat 19" off floor or provide removable seat, depending on availability on selected model. Include 2 1-1/2" outside diameter grab bars*. A single lever control valve shall feed a fixed shower head and a hand held shower with 5' of stainless steel wrapped hose, through a single lever diversion valve. *It is the contractor's responsibility to coordinate with homeowner on grab bar positioning. Determine positioning prior to purchasing shower unit to ensure if a grab bar within the shower is necessary and if available models accommodate that positioning.	1.00	EA	\$4000	\$4000
Location Total:					\$4500

Location: 5 - LR, Hall, NW Bedroom Approx. Wall SF: 0 Ceiling/Floor SF: 0

Spec #	Spec	Quantity	Units	Unit Price	Total Price
Trade: 10 Carpentry					

Address: REDACTED 10 Unit: Unit 01

Location: 5 - LR, Hall, NW Bedroom Approx. Wall SF: 0 Ceiling/Floor SF: 0

Spec # Spec Quantity Units Unit Price Total Price

Trade: 10 Carpentry

8 5909 VINYL PLANK FLOORING -- INSTALL 375.00 SF \$8 \$3000

Remove existing flooring. Install new vinyl plank flooring in owner's choice of color from in-stock options. New vinyl plank floor will be 100% waterproof- Home Depot Home Decorators style vinyl plank flooring or approved equal 4.2 mm thickness or greater. Include all transition pieces at hallways and base trim.

It is homeowners' responsibility to move furniture and obstacles to allow for contractor installation. Contractor must coordinate this installation with homeowner

Location Total: \$3000

Unit Total for REDACTED 10 : \$15,150

Address Grand Total for REDACTED 10 : \$15,150

Bidder: Blackout Construction LLC



Specs By Location

4/2/2026

Address: REDACTED 11 **Unit:** Unit 01

Location: 1 - General Requirements **Approx. Wall SF:** 0 **Ceiling/Floor SF:** 0

Spec #	Spec	Quantity	Units	Unit Price	Total Price
Trade: 1 General Requirements					
1	36 BUILDING PERMIT REQUIRED The contractor is responsible for submitting this owner-prepared work write up to the building department, applying for, paying for and receiving a building permit prior to starting any work. Contractor will also be responsible for coordinating a final inspection by the local building department.	1.00	EA	\$500	\$500
2	37 ELECTRICAL PERMIT REQUIRED Prior to the start of work, the contractor shall create any documentation necessary to apply for, pay for and receive an electrical permit on behalf of the owner.	1.00	EA	\$500	\$500
3	38 PLUMBING PERMIT REQUIRED Prior to the start of work, the contractor shall, if necessary: create a riser diagram, septic layout and all other documentation needed to apply for, pay for and receive a plumbing permit on behalf of the owner.	1.00	EA	\$500	\$500
Trade: 5 Demolition & Disposal					
4	800 DUMPSTER--20 CUBIC YARDS After procuring all required permits, place a 20 cubic yard, roll-off dumpster or equivalent disposal method without damaging the site. Collect construction debris using dust control methods.	1.00	EA	\$500	\$500
Location Total:					\$2000

Location: 2 - Exterior **Approx. Wall SF:** 0 **Ceiling/Floor SF:** 0

Spec #	Spec	Quantity	Units	Unit Price	Total Price
Trade: 10 Carpentry					
5	3580 LOW-RISE STAIR SYSTEM Remove steps and handrail at front entry. Replace with low rise treated stair system with handrails on both sides. Stairs to have a 11" minimum run, and 7" maximum rise.	1.00	EA	\$500	\$500
6	3975 WHEELCHAIR RAMP At rear of house, demolish and dispose of porch. Design and construct a preservative treated wood wheelchair ramp complete with 2"x4" safety handrails and non-slip 3/4" plywood surface treatment supported by 4"x4" post set 36" in ground, in	164.00	SF	\$30	\$4920

Address: REDACTED 11 Unit: Unit 01

Location: 2 - Exterior Approx. Wall SF: 0 Ceiling/Floor SF: 0

Spec #	Spec	Quantity	Units	Unit Price	Total Price
--------	------	----------	-------	------------	-------------

Trade: 10 Carpentry

conformance with ANSI recommendations. Slope shall not exceed 1'0" rise to 12'0"run. Minimum inside width, 36" Submit preliminary drawing to owner for approval

Location Total: \$5420

Location: 3 - Kitchen Approx. Wall SF: 0 Ceiling/Floor SF: 0

Spec #	Spec	Quantity	Units	Unit Price	Total Price
--------	------	----------	-------	------------	-------------

Trade: 10 Carpentry

7	Custom	TRANSITION STRIP -- INSTALL	2.00	EA	\$50	\$100
Install transition strips at both openings of kitchen to ensure smooth and safe transitions between rooms.						

Location Total: \$100

Location: 4 - NW Bedroom Approx. Wall SF: 0 Ceiling/Floor SF: 0

Spec #	Spec	Quantity	Units	Unit Price	Total Price
--------	------	----------	-------	------------	-------------

Trade: 10 Carpentry

8	5909	VINYL PLANK FLOORING -- INSTALL	110.00	SF	8	\$880
Install new vinyl plank flooring over existing floor in owner's choice of color from in-stock options. New vinyl plank floor will be 100% waterproof- Home Depot Home Decorators style vinyl plank flooring or approved equal 4.2 mm thickness or greater. Include all transition pieces at hallways, base trim, and stair nosing covers.						

It is homeowners' responsibility to move furniture and obstacles to allow for contractor installation. Contractor must coordinate this installation with homeowner

Trade: 21 HVAC

9	6415	DRYER VENT	1.00	EA	\$250	\$250
Install 4" round rigid galvanized ductwork from the specified dryer location to a wall mounted Heartland Dryer Vent Closure outlet or equivalent. Do not fasten with nails, screws or other fasteners that protrude into the interior of the exhaust duct. Use pop rivets to connect sections of duct. Seal all joints and seams with duct mastic, not duct tape. Secure duct and hood to framing.						

Trade: 22 Plumbing

10	6715	DRAIN, WASTE, VENT--PVC	15.00	LF	\$50	\$750
Install schedule 40 PVC drain pipe and fittings for washing machine drain and attach to plumbing stack. Install pipe with hangers 3' on center, if necessary, without critical damage to						

Address: REDACTED 11 **Unit: Unit 01**

Location: 4 - NW Bedroom **Approx. Wall SF: 0** **Ceiling/Floor SF: 0**

Spec #	Spec	Quantity	Units	Unit Price	Total Price
--------	------	----------	-------	------------	-------------

Trade: 22 Plumbing

structural members. Install drain and vent to code.

11	7120	WASHING MACHINE OUTLET BOX -- INSTALL	1.00	EA	\$1500	\$1500
----	------	--	------	----	--------	--------

Tap into hot and cold water lines in basement to install washing machine outlet box, running plumbing through interior wall to prevent freezing. This will serve as the connection point for first floor laundry. Coordinate with homeowner on location and repair all tearout.

Trade: 23 Electric

12	7615	WASHER CIRCUIT 110/20 AMP	1.00	EA	\$200	\$200
----	------	----------------------------------	------	----	-------	-------

Install a flush or surface mounted ivory GFCI duplex outlet for a washing machine on a separate 20 amp circuit using #12 copper NM cable.

13	7620	DRYER CIRCUIT--30 AMP	1.00	EA	\$350	\$350
----	------	------------------------------	------	----	-------	-------

Install 220 volt, 30 amp, surface mounted receptacle on an individual circuit.

Location Total: \$3930

Location: 5 - NW Bathroom **Approx. Wall SF: 0** **Ceiling/Floor SF: 0**

Spec #	Spec	Quantity	Units	Unit Price	Total Price
--------	------	----------	-------	------------	-------------

Trade: 10 Carpentry

14	5909	VINYL PLANK FLOORING -- INSTALL	25.00	SF	\$8	\$200
----	------	--	-------	----	-----	-------

Remove existing flooring. Install new vinyl plank flooring in owner's choice of color from in-stock options. New vinyl plank floor will be 100% waterproof- Home Depot Home Decorators style vinyl plank flooring or approved equal 4.2 mm thickness or greater. Include all transition pieces at hallways, base trim, and stair nosing covers.

Location Total: \$200

Location: 6 - Basement **Approx. Wall SF: 0** **Ceiling/Floor SF: 0**

Spec #	Spec	Quantity	Units	Unit Price	Total Price
--------	------	----------	-------	------------	-------------

Trade: 10 Carpentry

15	2520	HANDRAIL--REPLACE INTERIOR	14.00	LF	\$10	\$140
----	------	-----------------------------------	-------	----	------	-------

Install 2" round hardwood handrail to code, screwed to metal handrail braces that are attached to studs with screws that enter the framing at least 1 inch, or if fastening to a masonry wall use minimum 3/8 inch diameter plastic masonry plug fasteners and compatible screws. All edges will be eased to a smooth and rounded condition.

Trade: 23 Electric

Address: REDACTED 11 **Unit: Unit 01**

Location: 6 - Basement **Approx. Wall SF: 0** **Ceiling/Floor SF: 0**

Spec # Spec **Quantity Units Unit Price Total Price**

Trade: 23 Electric

16	7470	ELECTRIC SERVICE--150 AMP Replace existing electrical service with a residential, 150 amp, single phase, 3 wire electric service. Include a main disconnect, 22 circuit panel board, meter socket, weather head, service cable, and ground rod and cable. Seal exterior service penetration.	1.00	EA	<u>\$5000</u>	<u>\$5000</u>
----	------	--	------	----	---------------	---------------

Location Total: \$5140

Unit Total for REDACTED 11: \$16,790

Address Grand Total for REDACTED 11: \$16,790

Bidder: Blackout Construction LLC



Specs By Location

4/2/2026

Address: REDACTED 12		Unit: Unit 01			
Location: 1 - General Requirements		Approx. Wall SF: 0	Ceiling/Floor SF: 0		
Spec #	Spec	Quantity	Units	Unit Price	Total Price
Trade: 1 General Requirements					
1	38 PLUMBING PERMIT REQUIRED Prior to the start of work, the contractor shall, if necessary: create a riser diagram, septic layout and all other documentation needed to apply for, pay for and receive a plumbing permit on behalf of the owner.	1.00	EA	\$500	\$500
Trade: 5 Demolition & Disposal					
2	800 DUMPSTER--20 CUBIC YARDS After procuring all required permits, place a 20 cubic yard, roll-off dumpster or equivalent disposal method without damaging the site. Collect construction debris using dust control methods.	1.00	EA	\$500	\$500
Trade: 6 Concrete & Paving					
3	850 CONCRETE--GENERAL REQS. All concrete shall be 3% air entrained, ready mix, 2500 psi, max.4" slump, unless otherwise specified. Place all concrete on original soil or wet fill compacted to 90% against straight, solid, forms between temps.of 40-100 F. All concrete shall be: free of voids and cavities; treated with a liquid curing compound and protected from the weather while curing.	1.00	EA	\$0	\$0
Location Total:					\$1000

Location: 2 - Exterior		Approx. Wall SF: 0	Ceiling/Floor SF: 0		
Spec #	Spec	Quantity	Units	Unit Price	Total Price
Trade: 6 Concrete & Paving					
4	855 DEMO CONCRETE Break up concrete walkway from driveway to front steps and remove off site to code legal dump.	70.00	SF	\$5	\$350
5	1065 CONCRETE FORMWORK--CUSTOM Form and pour new concrete walkway from front steps to driveway. Ensure proper substrate and compaction based on requirements listed in the "General Requirements" Section of this spec sheet and according to all local building code requirements and manufacturer specifications. Broom finish.	100.00	SF	\$27.50	\$2750

Address: REDACTED 12 **Unit: Unit 01**

Location: 2 - Exterior Approx. Wall SF: 0 Ceiling/Floor SF: 0

Spec #	Spec	Quantity	Units	Unit Price	Total Price
--------	------	----------	-------	------------	-------------

Trade: 10 **Carpentry**

6	3530 GUARD RAIL--WROUGHT IRON Install a black, wrought iron railing of bar stock wrought steel with solid twist balusters. Bolt securely in wall and floor with lead shielded lag bolts. Embed in concrete in ground when servicing steps. Touch up paint.	16.00	LF	\$11	\$176
---	--	-------	----	------	-------

7	3580 LOW-RISE STAIR SYSTEM - CONCRETE Remove steps and handrail at front entry. Replace with low rise concrete stair system to have a 11" minimum run, and 7" maximum rise. Expand stair footprint to match width of porch.	1.00	EA	\$500	\$500
---	---	------	----	-------	-------

See rear entrance for template

Location Total: \$3776

Location: 3 - North Bathroom Approx. Wall SF: 0 Ceiling/Floor SF: 0

Spec #	Spec	Quantity	Units	Unit Price	Total Price
--------	------	----------	-------	------------	-------------

Trade: 10 **Carpentry**

8	5909 VINYL PLANK FLOORING -- INSTALL Remove existing flooring. Install new vinyl plank flooring in owner's choice of color from in-stock options. New vinyl plank floor will be 100% waterproof- Home Depot Home Decorators style vinyl plank flooring or approved equal 4.2 mm thickness or greater. Include all transition pieces at hallways, base trim, and stair nosing covers.	24.00	SF	\$8	\$192
---	--	-------	----	-----	-------

Trade: 22 **Plumbing**

9	7011 COMMODO--ACCESSIBLE Install a 2 piece, close coupled, white, vitreous china, comfort height commode with a maximum water usage per flush of 1.6 Gallons. Include plastic or pressed wood white seat, supply pipe, shut-off valve, flap valve and wax seal. Use 14" rough-in when replacing wall hung commode, and 12" rough-in to replace close coupled commode. Commode shall measure at least 19" from floor to top of seat.	1.00	EA	\$450	\$450
---	---	------	----	-------	-------

Location Total: \$642

Location: 4 - South Bathroom Approx. Wall SF: 0 Ceiling/Floor SF: 0

Spec #	Spec	Quantity	Units	Unit Price	Total Price
--------	------	----------	-------	------------	-------------

Trade: 10 **Carpentry**

10	5909 VINYL PLANK FLOORING -- INSTALL Install new vinyl plank flooring over existing flooring in owner's choice of color from in-stock options. New vinyl plank floor will be 100% waterproof- Home Depot Home Decorators style vinyl plank flooring or approved equal 4.2 mm thickness or greater. Include all transition pieces at hallways, base trim, and stair	35.00	SF	\$8	\$280
----	--	-------	----	-----	-------

Address: REDACTED 12 Unit: Unit 01

Location: 4 - South Bathroom Approx. Wall SF: 0 Ceiling/Floor SF: 0

Spec #	Spec	Quantity	Units	Unit Price	Total Price
--------	------	----------	-------	------------	-------------

Trade: 10 Carpentry
nosing covers.

Trade: 22 Plumbing

11	7011	COMMODE--ACCESSIBLE	1.00	EA	\$450	\$450
----	------	---------------------	------	----	-------	-------

Install a 2 piece, close coupled, white, vitreous china, comfort height commode with a maximum water usage per flush of 1.6 Gallons. Include plastic or pressed wood white seat, supply pipe, shut-off valve, flap valve and wax seal. Use 14" rough-in when replacing wall hung commode, and 12" rough-in to replace close coupled commode. Commode shall measure at least 19" from floor to top of seat.

12	7290	SHOWER--ACCESSIBLE	1.00	EA	\$4000	\$4000
----	------	--------------------	------	----	--------	--------

Remove existing tub and tile surround. Install a STERLING Accord Shower Stall or equal to fit existing opening. Floor shall be non-slip with a maximum 4" lip at entrance. Include hinged seat 19" off floor or provide removable seat, depending on availability on selected model. Include 2 1-1/2" outside diameter grab bars*. A single lever control valve shall feed a fixed shower head and a hand held shower with 5' of stainless steel wrapped hose, through a single lever diversion valve. Repair all tearout.

*It is the contractor's responsibility to coordinate with homeowner on grab bar positioning. Determine positioning prior to purchasing shower unit to ensure if a grab bar within the shower is necessary and if available models accommodate that positioning.

Location Total: \$4730

Unit Total for REDACTED 12: \$10,148

Address Grand Total for REDACTED 12: \$10,148

Bidder: Blackout Construction LLC



Specs By Location

4/7/2026

Address: REDACTED 13		Unit: Unit 01			
Location: 1 - General Requirements		Approx. Wall SF: 0		Ceiling/Floor SF: 0	
Spec #	Spec	Quantity	Units	Unit Price	Total Price
Trade: 1 General Requirements					
1	38	1.00	EA	\$500	\$500
	PLUMBING PERMIT REQUIRED Prior to the start of work, the contractor shall, if necessary: create a riser diagram, septic layout and all other documentation needed to apply for, pay for and receive a plumbing permit on behalf of the owner.				
Trade: 6 Concrete & Paving					
2	850	1.00	EA	\$0	\$0
	CONCRETE--GENERAL REQS. All concrete shall be 3% air entrained, ready mix, 2500 psi, max.4" slump, unless otherwise specified. Place all concrete on original soil or wet fill compacted to 90% against straight, solid, forms between temps.of 40-100 F. All concrete shall be: free of voids and cavities; treated with a liquid curing compound and protected from the weather while curing.				
Location Total:					\$500
Location: 2 - Exterior		Approx. Wall SF: 0		Ceiling/Floor SF: 0	
Spec #	Spec	Quantity	Units	Unit Price	Total Price
Trade: 5 Demolition & Disposal					
3	765	15.00	SF	\$5	\$75
	DEMO CONCRETE Remove tavers at front porch and save them for homeowner. Break up concrete pad in front of porch and remove off site to code legal dump.				
Trade: 6 Concrete & Paving					
4	1065	15.00	EA	\$27.50	\$412.50
	CONCRETE FORMWORK--CUSTOM Form and pour new pad and step at front entry to porch. Step rise should be no more than 7" and tread no less 1". Ensure proper substrate and compaction based on requirements listed in the "General Requirements" Section of this spec sheet and according to all local building code requirements and manufacturer specifications. Broom finish.				
Trade: 10 Carpentry					
5	3530	14.00	LF	\$11	\$154
	GUARD RAIL--WROUGHT IRON On both sides of front porch, going down steps, install a black,				

Address: REDACTED 13

Unit: Unit 01

Location: 2 - Exterior

Approx. Wall SF: 0

Ceiling/Floor SF: 0

Spec #	Spec	Quantity	Units	Unit Price	Total Price
--------	------	----------	-------	------------	-------------

Trade: 10 Carpentry

wrought iron railing of bar stock wrought steel with solid twist balusters. Bolt securely in wall and floor with lead shielded lag bolts. Embed in concrete in ground when servicing steps. Touch up paint.

Location Total: \$641.50

Location: 3 - Bathroom

Approx. Wall SF: 0

Ceiling/Floor SF: 0

Spec #	Spec	Quantity	Units	Unit Price	Total Price
--------	------	----------	-------	------------	-------------

Trade: 22 Plumbing

6	7290	SHOWER--ACCESSIBLE	1.00	EA	\$4000	\$4000
---	------	--------------------	------	----	--------	--------

Remove existing tub and surround. Install a STERLING Accord Shower Stall or equal to fit existing opening. Floor shall be non-slip with a maximum 4" lip at entrance. Include hinged seat 19" off floor or provide removable seat, depending on availability on selected model. Include 2 1-1/2" outside diameter grab bars*, A single lever control valve shall feed a fixed shower head and a hand held shower with 5' of stainless steel wrapped hose, through a single lever diversion valve.

*It is the contractor's responsibility to coordinate with homeowner on grab bar positioning. Determine positioning prior to purchasing shower unit to ensure if a grab bar within the shower is necessary and if available models accommodate that positioning.

Location Total: \$4000

Unit Total for REDACTED 13: \$5141.50

Address Grand Total for REDACTED 13: \$5141.50

Bidder: Blackout Construction LLC

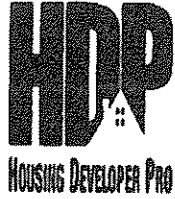

Specs By Location

4/2/2026

Address: REDACTED 14 **Unit: Unit 01**

Location: 1 - General Requirements **Approx. Wall SF: 0** **Ceiling/Floor SF: 0**

Spec #	Spec	Quantity	Units	Unit Price	Total Price
--------	------	----------	-------	------------	-------------

Trade: 1 General Requirements

1	36	BUILDING PERMIT REQUIRED	1.00	EA	\$500	\$500
<p>The contractor is responsible for submitting this owner-prepared work write up to the building department, applying for, paying for and receiving a building permit prior to starting any work. Contractor will also be responsible for coordinating a final inspection by the local building department.</p>						

Location Total: \$500

Location: 2 - Exterior **Approx. Wall SF: 0** **Ceiling/Floor SF: 0**

Spec #	Spec	Quantity	Units	Unit Price	Total Price
--------	------	----------	-------	------------	-------------

Trade: 10 Carpentry

2	3975	WHEELCHAIR RAMP	384.00	SF	\$30	\$7680
<p>Build a platform to cover porch area and provide a zero step entry. Design and construct a preservative treated wood wheelchair ramp complete with 2"x4" safety handrails and non-slip 3/4" plywood surface treatment supported by 4"x4" post set 36" in ground, in conformance with ANSI recommendations. Slope shall not exceed 1'0" rise to 12'0"run. Minimum inside width, 36". Complete installation by building an additional step at porch entrance from stairs. Submit preliminary drawing to owner for approval.</p>						

Location Total: \$11,520

Unit Total for REDACTED 14: \$12,020

Address Grand Total for REDACTED 14: \$12,020

Bllder: Blackout Construction LLC



Specs By Location

4/6/2026

Address: REDACTED 15 **Unit: Unit 01**

Location: 1 - General Requirements **Approx. Wall SF: 0** **Ceiling/Floor SF: 0**

Spec #	Spec	Quantity	Units	Unit Price	Total Price
--------	------	----------	-------	------------	-------------

Trade: 1 General Requirements

1	38	PLUMBING PERMIT REQUIRED Prior to the start of work, the contractor shall, if necessary: create a riser diagram, septic layout and all other documentation needed to apply for, pay for and receive a plumbing permit on behalf of the owner.	1.00	EA	\$500	\$500
---	----	---	------	----	-------	-------

Trade: 5 Demolition & Disposal

2	800	DUMPSTER--20 CUBIC YARDS After procuring all required permits, place a 20 cubic yard, roll-off dumpster or equivalent disposal method without damaging the site. Collect construction debris using dust control methods.	1.00	EA	\$500	\$500
---	-----	--	------	----	-------	-------

Location Total: \$1000

Location: 2 - Exterior **Approx. Wall SF: 0** **Ceiling/Floor SF: 0**

Spec #	Spec	Quantity	Units	Unit Price	Total Price
--------	------	----------	-------	------------	-------------

Trade: 1 General Requirements

3	3936	GRAB BAR -- INSTALL Coordinate with homeowner on placement and install grab bars on exterior at front and rear entries	2.00	EA	\$150	\$300
---	------	--	------	----	-------	-------

Trade: 10 Carpentry

4	3210	STORM DOOR -- REPLACE At rear entry, remove and dispose of existing storm door. Install a combination storm and screen door to match existing color and swing with adjustable closer and all requisite hardware.	1.00	EA	\$500	\$500
---	------	--	------	----	-------	-------

5	3530	GUARD RAIL--WROUGHT IRON At E side of entry, install a black, wrought iron railing of bar stock wrought steel with solid twist balusters. Bolt securely in wall and floor with lead shielded lag bolts. Embed in concrete in ground when servicing steps. Touch up paint.	6.00	LF	\$11	\$66
---	------	---	------	----	------	------

6	3580	LOW-RISE STAIR SYSTEM At rear entry, demolish and dispose of steps. Replace with low rise treated stair system with handrail on both sides. Stairs to have a 11" minimum run, and 7" maximum rise.	1,200.00	EA	\$500	\$500
---	------	--	----------	----	-------	-------

Address: REDACTED 15

Unit: Unit 01

Location Total: \$1366

Location: 3 - First Floor

Approx. Wall SF: 0

Ceiling/Floor SF: 0

Spec #	Spec	Quantity	Units	Unit Price	Total Price
--------	------	----------	-------	------------	-------------

Trade: 10 Carpentry

7	5909	VINYL PLANK FLOORING -- INSTALL	860.00	SF	\$8	\$6880
---	------	---------------------------------	--------	----	-----	--------

Throughout entire first floor where carpet exists, remove carpet. Install new vinyl plank flooring in owner's choice of color from in-stock options. New vinyl plank floor will be 100% waterproof- Home Depot Home Decorators style vinyl plank flooring or approved equal 4.2 mm thickness or greater. Include all transition pieces at hallways, base trim, and stair nosing covers.

It is homeowners' responsibility to move furniture and obstacles to allow for contractor installation. Contractor must coordinate this installation with homeowner

Location Total: \$6880

Location: 4 - 2nd Floor Master Bathroom

Approx. Wall SF: 0

Ceiling/Floor SF: 0

Spec #	Spec	Quantity	Units	Unit Price	Total Price
--------	------	----------	-------	------------	-------------

Trade: 1 General Requirements

8	3936	GRAB BAR -- INSTALL	2.00	EA	\$150	\$300
---	------	---------------------	------	----	-------	-------

Coordinate with homeowner on placement of 2 grab bars in shower area. Where installation is on frame wall, secure tightly to studs. If studs cannot be located, open the wall, install blocking and repair wall to original condition. Installation must be capable of withstanding stress and weight of a person pulling him/herself up. Grab bars of all stainless steel, 18 gauge, 1-1/4" outside diameter as made by Tubular Specialties Mfs., Inc. or equal.

Trade: 22 Plumbing

9	7011	COMMODOE--ACCESSIBLE	1.00	EA	\$450	\$450
---	------	----------------------	------	----	-------	-------

Remove existing commode and install a 2 piece, close coupled, white, vitreous china, comfort height commode with a maximum water usage per flush of 1.6 Gallons. Include plastic or pressed wood white seat, supply pipe, shut-off valve, flap valve and wax seal. Use 14" rough-in when replacing wall hung commode, and 12" rough-in to replace close coupled commode.

Location Total: \$750

Location: 5 - 2nd Floor SW Bathroom

Approx. Wall SF: 0

Ceiling/Floor SF: 0

Spec #	Spec	Quantity	Units	Unit Price	Total Price
--------	------	----------	-------	------------	-------------

Trade: 1 General Requirements

10	3936	GRAB BAR -- INSTALL	2.00	EA	\$150	\$300
----	------	---------------------	------	----	-------	-------

Coordinate with homeowner on placement of 2 grab bars in

Address: REDACTED 15 Unit: Unit 01

Location: 5 - 2nd Floor SW Bathroom Approx. Wall SF: 0 Ceiling/Floor SF: 0

Spec #	Spec	Quantity	Units	Unit Price	Total Price
--------	------	----------	-------	------------	-------------

Trade: 1 General Requirements

shower area. Where installation is on frame wall, secure tightly to studs. If studs cannot be located, open the wall, install blocking and repair wall to original condition. Installation must be capable of withstanding stress and weight of a person pulling him/herself up. Grab bars of all stainless steel, 18 gauge, 1-1/4" outside diameter as made by Tubular Specialties Mfs., Inc. or equal.

11	Custom	SHOWER SEAT -- PROVIDE	1.00	EA	\$500	\$500
Contractor shall provide homeowner with a selection of in-stock shower seat options and purchase a shower seat to meet the homeowners' needs that fits in the shower area. Contractor shall assemble and adjust the seat to homeowners' requirements and place it in the shower.						

Trade: 10 Carpentry

12	3840	SHOWER CURTAIN ROD	1.00	EA	\$150	\$150
----	------	---------------------------	------	----	-------	-------

Remove and dispose of shower doors. Fill all holes or irregularities, flush with surrounding finish. Install a shower curtain rod using wall anchors.

Homeowner will be responsible for selecting and purchasing curtains

Trade: 23 Electric

13	7820	BATH VENT FAN/LIGHT FIXTURE--ENERGY STAR--REPLACE EXISTING	1.00	EA	\$1300	\$1300
----	------	---	------	----	--------	--------

Remove existing bath vent fan and install an ENERGY STAR approved ceiling mounted Fan/Light fixture, such as the Panasonic Wisper Green with an internal damper, and vented to the exterior. The fixture must accommodate Switch fan & light using a single switch with a time delay for the fan such as the EFI Fan/Light Time Delay Switch or equipped with a humidistat sensor. Ensure proper ventillation to exterior. Insulate the ductwork with vinyl or foil faced R 8 minimum duct insulation. Repair any tear out.

Location Total: \$2250

Location: 6 - Stairs Approx. Wall SF: 0 Ceiling/Floor SF: 0

Spec #	Spec	Quantity	Units	Unit Price	Total Price
--------	------	----------	-------	------------	-------------

Trade: 10 Carpentry

14	2520	HANDRAIL--REPLACE INTERIOR	15.00	LF	\$10	\$150
----	------	-----------------------------------	-------	----	------	-------

Install a hardwood handrail to match North side handrail as closely as possible. Screw metal handrail braces that are attached to studs with screws that enter the framing at least 1 inch, or if fastening to a masonry wall use minimum 3/8 inch diameter plastic masonry plug fasteners and compatible screws. All edges will be eased to a smooth and rounded condition.

Address: REDACTED 15 Unit: Unit 01

Location: 6 - Stairs Approx. Wall SF: 0 Ceiling/Floor SF: 0

Spec #	Spec	Quantity	Units	Unit Price	Total Price
--------	------	----------	-------	------------	-------------

Trade: 10 Carpentry

15	Custom HALF WALL -- BUILD	12.00	SF	\$150	\$1800
Remove existing railing at top of stairs. Use 2x4 framing studs to construct a half wall in it's place, secured to framing members below and on the East side. Drywall over studs, joining the seams of the adjacent wall to create a seamless finish. Finish with a top plate and base trim to match existing as closely as possible.					

Trade: 19 Paint & Wallpaper

16	5485 PREP & PAINT SURFACE	102.00	SF	\$4	\$408
On South wall of stairwell, remove or cover hardware and accessories not to be painted. Scrape loose, peeling, cracked and blistered areas. Clean oil, grease, fungus, dirt and dust from surfaces. Fill holes and cracks. Prime all new materials and spot prime existing with acrylic latex. Top coat with premixed acrylic latex to match existing in color and sheen. Replace or uncover hardware, fixtures and accessories.					

Location Total: \$2358

Unit Total for REDACTED 15: \$13,238

Address Grand Total for REDACTED 15: \$13,238

Bidder: Blackout Construction LLC



Specs By Location

4/2/2026

Address: REDACTED 16 **Unit: Unit 01**

Location: 1 - General Requirements **Approx. Wall SF: 0** **Ceiling/Floor SF: 0**

Spec #	Spec	Quantity	Units	Unit Price	Total Price
--------	------	----------	-------	------------	-------------

Trade: 1 General Requirements

1	36	BUILDING PERMIT REQUIRED	1.00	EA	\$500	\$500
<p>The contractor is responsible for submitting this owner-prepared work write up to the building department, applying for, paying for and receiving a building permit prior to starting any work. Contractor will also be responsible for coordinating a final inspection by the local building department.</p>						
2	38	PLUMBING PERMIT REQUIRED	1.00	EA	\$500	\$500
<p>Prior to the start of work, the contractor shall, if necessary: create a riser diagram, septic layout and all other documentation needed to apply for, pay for and receive a plumbing permit on behalf of the owner.</p>						

Trade: 5 Demolition & Disposal

3	800	DUMPSTER--20 CUBIC YARDS	1.00	EA	\$500	\$500
<p>After procuring all required permits, place a 20 cubic yard, roll-off dumpster or equivalent disposal method without damaging the site. Collect construction debris using dust control methods.</p>						

Location Total: \$1500

Location: 2 - Exterior **Approx. Wall SF: 0** **Ceiling/Floor SF: 0**

Spec #	Spec	Quantity	Units	Unit Price	Total Price
--------	------	----------	-------	------------	-------------

Trade: 10 Carpentry

4	3185	DOOR--PREHUNG METAL ENTRANCE	1.00	EA	\$1100	\$1100
<p>Dispose of door and frame. Install a prehung metal, insulated, 6-panel entrance door and jamb including interior and exterior casing, peep hole, weatherstripping, interlocking threshold, one entrance and one mortised deadbolt keyed alike. Prime and top coat.</p> <p>**Install a door that includes a zero step threshold**</p>						
5	3210	STORM DOOR -- REPLACE	1.00	EA	\$500	\$500
<p>Remove and dispose of existing storm door. Install a combination storm and screen door to match existing with adjustable closer and all requisite hardware.</p> <p>**Install a storm door with opposite swing for wheelchair ramp</p>						

Address: REDACTED 16		Unit: Unit 01			
Location: 2 - Exterior		Approx. Wall SF: 0	Ceiling/Floor SF: 0		
Spec #	Spec	Quantity	Units	Unit Price	Total Price
Trade: 10		Carpentry			
		access**			
6	3975	132.00	SF	\$30	\$3960
	WHEELCHAIR RAMP Build a platform on top of concrete porch for a zero step entry. Design and construct a preservative treated wood wheelchair ramp complete with 2"x4" safety handrails and non-slip 3/4" plywood surface treatment supported by 4"x4" post set 36" in ground, in conformance with ANSI recommendations. Slope shall not exceed 1'0" rise to 12'0"run. Minimum inside width, 36" Submit preliminary drawing to owner for approval.				
Location Total:					\$5560
Location: 3 - Bathroom		Approx. Wall SF: 0	Ceiling/Floor SF: 0		
Spec #	Spec	Quantity	Units	Unit Price	Total Price
Trade: 1		General Requirements			
7	Custom	1.00	EA	\$200	\$200
	TOILET SAFETY RAIL -- INSTALL Install Toilet Safety Rail attached to rear of toilet seat and adjusted for homeowner's use.				
Trade: 18		Ceramic Tile			
8	5430	33.00	SF	\$40	\$1320
	CERAMIC WALL TILE Install matching or as close as possible to matching ceramic tile per manufacturer's specifications to finish shower installation below where tub was previously installed				
Trade: 22		Plumbing			
9	7011	1.00	EA	\$450	\$450
	COMMODOE--ACCESSIBLE Remove existing commode. Install a 2 piece, close coupled, white, vitreous china, comfort height commode with a maximum water usage per flush of 1.6 Gallons. Include plastic or pressed wood white seat, supply pipe, shut-off valve, flap valve and wax seal. Use 14" rough-in when replacing wall hung commode, and 12" rough-in to replace close coupled commode. Commode shall measure at least 19" from floor to top of seat.				
10	7290	1.00	EA	\$4000	\$4000
	SHOWER--ACCESSIBLE Remove existing tub while leaving surround. Install a STERLING Accord Shower Stall or equal to fit existing opening. Floor shall be non-slip with a maximum 4" lip at entrance. Provide removable seat. Include 2 1-1/2" outside diameter grab bars*, A single lever control valve shall feed a fixed shower head and a hand held shower with 5' of stainless steel wrapped hose, through a single lever diversion valve.				
This spec calls for replacing the shower pan only, no walls					
*It is the contractor's responsibility to coordinate with homeowner on grab bar positioning. Determine positioning prior to purchasing shower unit to ensure if a grab bar within					

Address: REDACTED 16

Unit: Unit 01

Location: 3 - Bathroom

Approx. Wall SF: 0

Ceiling/Floor SF: 0

Spec #	Spec	Quantity	Units	Unit Price	Total Price
--------	------	----------	-------	------------	-------------

Trade: 22 Plumbing

the shower is necessary and if available models accommodate that positioning.

Location Total: \$5970

Location: 4 - Kitchen/Utility Room

Approx. Wall SF: 0

Ceiling/Floor SF: 0

Spec #	Spec	Quantity	Units	Unit Price	Total Price
--------	------	----------	-------	------------	-------------

Trade: 10 Carpentry

11	5909	VINYL PLANK FLOORING -- INSTALL	180.00	SF	\$8	\$1440
----	------	---------------------------------	--------	----	-----	--------

Remove existing flooring. Install new vinyl plank flooring in owner's choice of color from in-stock options. New vinyl plank floor will be 100% waterproof- Home Depot Home Decorators style vinyl plank flooring or approved equal 4.2 mm thickness or greater. Include all transition pieces at hallways, base trim, and stair nosing covers.

It is homeowners' responsibility to move furniture and obstacles to allow for contractor installation. Contractor must coordinate this installation with homeowner

Location Total: \$1440

Unit Total for REDACTED 16: \$14,470

Address Grand Total for REDACTED 16: \$14,470

Bidder: Blackout Construction LLC



Specs By Location

4/14/2026

Address: REDACTED 17		Unit: Unit 01					
Location: 1 - General Requirements		Approx. Wall SF: 0	Ceiling/Floor SF: 0				
Spec #	Spec	Quantity	Units	Unit Price	Total Price		
Trade: 1	General Requirements						
1	37	1.00	EA	\$500	\$500		
	ELECTRICAL PERMIT REQUIRED						
	Prior to the start of work, the contractor shall create any documentation necessary to apply for, pay for and receive an electrical permit on behalf of the owner.						
2	38	1.00	EA	\$500	\$500		
	PLUMBING PERMIT REQUIRED						
	Prior to the start of work, the contractor shall, if necessary: create a riser diagram, septic layout and all other documentation needed to apply for, pay for and receive a plumbing permit on behalf of the owner.						
					Location Total:		\$1000
Location: 2 - Bathroom		Approx. Wall SF: 0	Ceiling/Floor SF: 0				
Spec #	Spec	Quantity	Units	Unit Price	Total Price		
Trade: 10	Carpentry						
3	5909	36.00	SF	\$8	\$288		
	VINYL PLANK FLOORING -- INSTALL						
	Remove existing flooring. Install new vinyl plank flooring in owner's choice of color from in-stock options. New vinyl plank floor will be 100% waterproof- Home Depot Home Decorators style vinyl plank flooring or approved equal 4.2 mm thickness or greater. Include all transition pieces at hallways, base trim, and stair nosing covers.						
	It is homeowners' responsibility to move furniture and obstacles to allow for contractor installation. Contractor must coordinate this installation with homeowner						
Trade: 22	Plumbing						
4	7010	1.00	EA	\$450	\$450		
	COMMODO--REPLACE						
	Remove and dispose of existing commode. Install a 2 piece, close coupled, white, vitreous china, commode with a maximum water usage per flush of 1.6 Gallons. Include plastic or pressed wood white seat, supply pipe, shut-off valve, flap valve and wax seal. Use 14" rough-in when replacing wall hung commode, and 12" rough-in to replace close coupled commode.						
	Install standard-height commode, existing comfort height is too tall						
5	7290	1.00	EA	\$4000	\$4000		
	SHOWER--ACCESSIBLE						

Address: REDACTED 17		Unit: Unit 01	
Location:	2 - Bathroom	Approx. Wall SF: 0	Ceiling/Floor SF: 0
Spec #	Spec	Quantity	Units
		Unit Price	Total Price

Trade: 22 Plumbing

Remove existing tub and surround. Install a STERLING Accord Shower Stall or equal to fit existing opening. Floor shall be non-slip with a maximum 4" lip at entrance. Include hinged seat 19" off floor or provide removable seat, depending on availability on selected model. Include 2 1-1/2" outside diameter grab bars*. A single lever control valve shall feed a fixed shower head and a hand held shower with 5' of stainless steel wrapped hose, through a single lever diversion valve.

*It is the contractor's responsibility to coordinate with homeowner on grab bar positioning. Determine positioning prior to purchasing shower unit to ensure if a grab bar within the shower is necessary and if available models accommodate that positioning.

Trade: 23 Electric

6	7819	BATH VENT FAN/LIGHT FIXTURE--NEW--ENERGY STAR	1.00	EA	\$1300	\$1300
<p>Install an ENERGY STAR approved ceiling mounted Fan/Light fixture, such as the Panasonic Wisper Green with an internal damper, and vented to the exterior. The fixture must accommodate Switch fan & light using a single switch with a time delay for the fan such as the EFI Fan/Light Time Delay Switch or equipped with a humidistat sensor. Insulate the ductwork with vinyl or foil faced R 8 minimum duct insulation. Insure proper ventallation to exterior. Include power and switch wiring using #14 copper Romex. Repair any tear out.</p>						

Location Total: \$6038

Unit Total for REDACTED 17: \$7038

Address Grand Total for REDACTED 17: \$7038

Bidder: Blackout Construction LLC



Specs By Location

4/14/2026

Address: REDACTED 18 **Unit: Unit 01**

Location: 1 - General Requirements **Approx. Wall SF: 0** **Ceiling/Floor SF: 0**

Spec #	Spec	Quantity	Units	Unit Price	Total Price
Trade: 1 General Requirements					
1	36 BUILDING PERMIT REQUIRED The contractor is responsible for submitting this owner-prepared work write up to the building department, applying for, paying for and receiving a building permit prior to starting any work. Contractor will also be responsible for coordinating a final inspection by the local building building department.	1.00	EA	\$500	\$500
2	38 PLUMBING PERMIT REQUIRED Prior to the start of work, the contractor shall, if necessary: create a riser diagram, septic layout and all other documentation needed to apply for, pay for and receive a plumbing permit on behalf of the owner.	1.00	EA	\$500	\$500
Trade: 5 Demolition & Disposal					
3	800 DUMPSTER--20 CUBIC YARDS After procuring all required permits, place a 20 cubic yard, roll-off dumpster or equivalent disposal method without damaging the site. Collect construction debris using dust control methods.	1.00	EA	\$500	\$500
Trade: 6 Concrete & Paving					
4	850 CONCRETE--GENERAL REQS. All concrete shall be 3% air entrained, ready mix, 2500 psi, max.4" slump, unless otherwise specified. Place all concrete on original soil or wet fill compacted to 90% against straight, solid, forms between temps.of 40-100 F. All concrete shall be: free of voids and cavities; treated with a liquid curing compound and protected from the weather while curing.	1.00	EA	\$0	\$0
Location Total:					\$1500

Location: 2 - Exterior **Approx. Wall SF: 0** **Ceiling/Floor SF: 0**

Spec #	Spec	Quantity	Units	Unit Price	Total Price
Trade: 5 Demolition & Disposal					
5	765 DEMO CONCRETE Break up driveway and 40SF of walkway concrete beyond backyard gate and remove off site to code legal dump.	840.00	SF	\$5	\$4200

Address: REDACTED 18 Unit: Unit 01

Location: 2 - Exterior Approx. Wall SF: 0 Ceiling/Floor SF: 0

Spec #	Spec	Quantity	Units	Unit Price	Total Price
--------	------	----------	-------	------------	-------------

Trade: 6 Concrete & Paving

6	980	DRIVEWAY--CONCRETE	800.00	SF	\$27.50	\$22,000
---	-----	--------------------	--------	----	---------	----------

Level surface, prepare a 3" gravel base over a uniformly graded & compacted subgrade. Form and pour 3000 psi air entrained concrete, 4" thick by 10' wide driveway. Provide #10 welded wire mesh, expansion joints at 10' intervals, and a broom finish surface that directs water away from the building. Remove forms. Regrade and seed disturbed areas.

7	1065	CONCRETE FORMWORK--CUSTOM	40.00	SF	\$27.50	\$1100
---	------	---------------------------	-------	----	---------	--------

Form and pour concrete landing and walkway for wheelchair ramp using the requirements specified in "General Requirements" at the top of the spec sheet.

Trade: 10 Carpentry

8	3975	WHEELCHAIR RAMP	184.00	SF	\$30	\$5520
---	------	-----------------	--------	----	------	--------

At rear of house, design and construct a preservative treated wood wheelchair ramp complete with 2"x4" safety handrails and non-slip 3/4" plywood surface treatment supported by 4"x4" post set 36" in ground, in conformance with ANSI recommendations. Slope shall not exceed 1'0" rise to 12'0"run. Minimum inside width, 36" Submit preliminary drawing to owner for approval.

****Design Proposal****
Remove railing from NW side of back deck, build 4x8 platform and begin slope Easterly to a second landing, then slope Southerly to walkway.

9	Custom	CONSTRUCT TRANSITION RAMP	9.00	SF	\$20	\$180
---	--------	---------------------------	------	----	------	-------

Construct a small transition ramp at rear entry threshold to transition from inside the home to the back deck.

Location Total: \$33,000

Location: 3 - Bathroom Approx. Wall SF: 0 Ceiling/Floor SF: 0

Spec #	Spec	Quantity	Units	Unit Price	Total Price
--------	------	----------	-------	------------	-------------

Trade: 10 Carpentry

10	5909	VINYL PLANK FLOORING -- INSTALL	25.00	SF	\$8	\$200
----	------	---------------------------------	-------	----	-----	-------

Remove existing flooring. Install new vinyl plank flooring in owner's choice of color from in-stock options. New vinyl plank floor will be 100% waterproof- Home Depot Home Decorators style vinyl plank flooring or approved equal 4.2 mm thickness or greater. Include all transition pieces at hallways, base trim, and stair nosing covers.

****It is homeowners' responsibility to move furniture and obstacles to allow for contractor installation. Contractor must coordinate this installation with homeowner****

Trade: 22 Plumbing

Address: REDACTED 18 **Unit: Unit 01**

Location: 3 - Bathroom **Approx. Wall SF: 0** **Ceiling/Floor SF: 0**

Spec # Spec **Quantity Units Unit Price Total Price**

Trade: 22 Plumbing

11 7290 **SHOWER--ACCESSIBLE** 1.00 EA \$4000 \$4000

Remove existing tub and surround. Install a STERLING Accord Shower Stall or equal to fit existing opening. Floor shall be non-slip with a maximum 4" lip at entrance. Include hinged seat 19" off floor or provide removable seat, depending on availability on selected model. Include 2 1-1/2" outside diameter grab bars*. A single lever control valve shall feed a fixed shower head and a hand held shower with 5' of stainless steel wrapped hose, through a single lever diversion valve.

*It is the contractor's responsibility to coordinate with homeowner on grab bar positioning. Determine positioning prior to purchasing shower unit to ensure if a grab bar within the shower is necessary and if available models accommodate that positioning.

Location Total: \$4200

Unit Total for REDACTED 18: \$38,700

Address Grand Total for REDACTED 18: \$38,700

Bidder: Blackout Construction LLC



Specs By Location

4/27/2026

Address:		Unit: Unit 01				
Location: 1 - Exterior		Approx. Wall SF: 0		Ceiling/Floor SF: 0		
Spec #	Spec	Quantity	Units	Unit Price	Total Price	
Trade: 10	Carpentry					
1	3120 DOOR--REPL ENTRANCE HARDWARE Replace security door and entry hardware with a lever handle set. Install double cylinder mortised deadbolt. Locks shall be keyed alike. Provide 2 sets of keys to the owner.	2.00	EA	\$600	\$1200	
2	3530 GUARD RAIL--WROUGHT IRON At front porch, dispose of any existing railing and supports. Install a black, wrought iron railing of bar stock wrought steel with solid twist balusters and supports. Bolt securely in wall and floor with lead shielded lag bolts. Embed in concrete in ground when servicing steps. Touch up paint. Include handrails on both sides of steps.	48.00	LF	\$11	\$528	
Location Total:					\$1728	

Location: 2 - Basement		Approx. Wall SF: 0		Ceiling/Floor SF: 0	
Spec #	Spec	Quantity	Units	Unit Price	Total Price
Trade: 10	Carpentry				
3	2520 HANDRAIL--REPLACE INTERIOR In stairwell to basement and landing area, install 2" round hardwood handrail to code, screwed to metal handrail braces that are attached to studs with screws that enter the framing at least 1 inch, or if fastening to a masonry wall use minimum 3/8 inch diameter plastic masonry plug fasteners and compatible screws. All edges will be eased to a smooth and rounded condition.	10.00	LF	\$10	\$100
Location Total:					\$100

Location: 3 - Stairs		Approx. Wall SF: 0		Ceiling/Floor SF: 0	
Spec #	Spec	Quantity	Units	Unit Price	Total Price
Trade: 10	Carpentry				
4	2520 HANDRAIL--REPLACE INTERIOR In stairwell to second story, install 2" round hardwood handrail to code, screwed to metal handrail braces that are attached to studs with screws that enter the framing at least 1 inch, or if fastening to a masonry wall use minimum 3/8 inch diameter plastic masonry plug fasteners and compatible screws. All edges will be eased to a smooth and rounded condition.	14.00	LF	\$10	\$140

Address: Unit: Unit 01

Location: 3 - Stairs Approx. Wall SF: 0 Ceiling/Floor SF: 0

Spec #	Spec	Quantity	Units	Unit Price	Total Price
--------	------	----------	-------	------------	-------------

Trade: 10 Carpentry

5	3525	GUARD RAIL--WOOD	3.00	LF	\$10	\$30
At top of stairwell, dispose of any existing railing. Construct a pine railing using 2"x 4" top and bottom rails, and 2"x 2" balusters face nailed 6" on center. Create a 3'6" high railing between 4"x 4" end posts.						

Location Total: \$170

Location: 4 - Kitchen Approx. Wall SF: 0 Ceiling/Floor SF: 0

Spec #	Spec	Quantity	Units	Unit Price	Total Price
--------	------	----------	-------	------------	-------------

Trade: 10 Carpentry

6	5909	VINYL PLANK FLOORING -- INSTALL	205.00	SF	\$8	\$1640
In kitchen, kitchen entry (steps and landing), hallway, and bathroom, remove flooring where it has not yet been removed. Install new vinyl plank flooring in owner's choice of color from in-stock options. New vinyl plank floor will be 100% waterproof- Home Depot Home Decorators style vinyl plank flooring or approved equal 4.2 mm thickness or greater. Include all transition pieces at hallways, base trim, and stair nosing covers.						

It is homeowners' responsibility to move furniture and obstacles to allow for contractor installation. Contractor must coordinate this installation with homeowner

Location Total: \$1640

Location: 5 - Entire Home Approx. Wall SF: 0 Ceiling/Floor SF: 0

Spec #	Spec	Quantity	Units	Unit Price	Total Price
--------	------	----------	-------	------------	-------------

Trade: 10 Carpentry

7	3135	DOOR HARDWARE--CUSTOM	10.00	EA	\$50	\$500
Throughout entire home, replace all interior door handle sets with lever operated handle sets with pushbutton locks.						

Do not include doors with original hardware

Location Total: \$500

Unit Total for #19: \$4138

Grand Total for #19: \$4138

Bidder: Blackout Construction LLC



City of Flint

Department of Purchases & Supplies

Sheldon A. Neeley

TO: All Proposers
FROM: Lauren Rowley, Purchasing Manager
DATE: April 28, 2026
SUBJECT: Addendum #01 – P26000513: CONSTRUCTION SERVICES FOR SCATTERED SINGLE-FAMILY HOME ADA REHABILITATION

This addendum has been issued to address the following clarifications:

Faucets/Fixtures

Best judgement is to be used for quality materials. A safe parameter is Delta or equivalent.

Property Condition

Repairs are restricted to permanent activities and defined as those necessary when a lack of repair or replacement threatens the safety of occupants and, if not addressed, will cause structural damage to the home, and are limited to the MI Neighborhood assisted activities list.

The assisted property must be currently occupied and not red-tagged or defined as uninhabitable based on local code. This program is not designed to address mold, animal infestations, or other immediate threats to the health and safety of residents. Change orders exceeding ten percent (10%) require MSHDA pre-authorization

MI Neighborhood Reimbursable Line Items

Accessibility: • Handrails • Grab Bars • Lower Closet Rods • Barrier-free Showers/Tubs • Lowering of Kitchen Cabinets • ADA Counter Tops • ADA Toilets and Vanities • Levered Door Handles • Toggle Light Switches • Ramps, front, side, back or garage • Zero-Step Entries • Self-closing Mechanisms • Widened Doorways & Offset Hinges • Universal Design Floor Coverings (not allowed as a standalone activity) • Updating of Dated and Dangerous Wiring to Be Able to Accommodate Medical Equipment Needs • Indoor/Outdoor Stairlifts • Modifying Rooms to Create First-Floor Bedrooms, Kitchens, Bathrooms • Laundry Rooms and/or Utility Rooms • Increasing Turn Around Radii and Bathroom Size to Accommodate Wheelchairs • Van Accessible Parking • Motion Lights • Vision or Hearing Aids – Permanent Household Fixtures Only

Procurement Requirements Procurement

Small purchase procedures are used to provide written documentation on how your agency will validate that the expenses made are reasonable and necessary. The purchase procedures should be part of your program guidelines and followed when selection of contractor(s) occur. A minimum of two written quotes/cost estimates must be obtained in writing, emails are acceptable. Must contain a name, date, scope of work for a specified property, and a dollar amount per activity. Quotes that are comparable in scope for each activity are needed. If the gap between the two quotes/cost estimates is equal to or greater than 25% (rounded) of the lowest quote/cost estimate, you must seek a third quote/estimate. The estimates can be from stores with dated receipts/ invoices, activities itemized by type and cost. All quotes/ estimates must be itemized and clearly documented and be comparable in scope and materials. The subrecipient must follow procurement procedures, obtain bids for all necessary work (labor and materials), and determine reasonableness.



City of Flint

Department of Purchases & Supplies

Property #19

The Property referred to as "Property #19" has had the information released that we were awaiting. The findings and pictures are attached to this addendum for your review.

Clarification of Handout given at Pre-Bid Meeting

Just a reiteration to remove Local Preference. The City will not be awarding or considering award based on Local preference and Local Preference Discount. That will not apply to this project/RFP.

Pre-Bid

The Pre-Bid Sign-In Sheet of Attendees and their contact information provided, has been attached to this addendum.

Permitting

Awarded vendors are responsible for obtaining permits for this project. The vendors can contact the City of Flint Building Safety and Inspection Division at (810) 766-7284. They are located at Flint City Hall, 1101 S. Saginaw St. Room S106, Flint, MI 48502. Their hours of operation are Monday-Thursday 9AM-3PM. Additional resources can be found at cityofflint.com/building-safety-inspections/

In the submission of their proposal, Proposer must acknowledge receipt of this addendum. Proposer shall acknowledge this addendum by signing and returning one copy of this notice with their submission.

Company Name: Blackout Construction LLC

Address: 34 Queen St

City / State / Zip: Mount Clemens, MI, 48043

Telephone: 989-494-7581 Fax: N/A Email: blackoutpaint@gmail.com

Print Name: Alex Bronson Title: Owner

Signature: Alex Bronson Date: _____

Thank you,

Lauren Rowley, Purchasing Manager

Blackout Construction

Alex Bronson

MEMO

34 Queen St
Mount Clemens, MI, 48043
Phone 989-494-7581
blackoutpaint@gmail.com

TO:
City of Flint
1101 S. Saginaw St
Flint, MI
48502

TO WHOM IT MAY CONCERN

My name is Alex Bronson, owner and operator of Blackout Construction. I wanted to write a memo to explain a few things about our proposal on the Flint property renovations. First thing would be materials. We would be using all Delta products on the bathrooms, unless a specific product was already proposed in the RFQ. Any other products we use would be code compliant and durable.

While reading through the RFQ, a few things were brought to our attention that we would consider errors and omissions:

- According to Michigan Residential Building Code HVAC permits are required when installing any bathroom vents that are vented to the exterior. We did not see any mention of HVAC permits throughout the RFQ. Any building inspector that comes onto the property will require this to be done.
- On several line items, any wording or mention of demolition work was present on some items and absent on others that would require it that could affect the price.
- On several properties, any wording or mention of other trades work that would be involved with these projects is absent. This would include trades such as painting, drywall, and trim. As an example, when tearing out a shower stall and replacing it we would absolutely need to do drywall repairs around the previous area to accommodate the new stall and then associated painting and trim work after. It is also hard to include prices in the RFQ for these items without exact measurements.
- One line item mentioned removing tile from the old shower to use where a medicine cabinet would be lowered. This would be impossible because the current tile is too small to salvage and any tile taken off an old surface would almost certainly be unusable and we wouldn't be able to properly warranty work without using new supplies.

I hope this clarifies a few things throughout our RFQ and if you have any questions or concerns, please feel free to reach out at any time.

RESPECTFULLY

Alex Bronson

Michigan Department of Licensing and Regulatory Affairs
Bureau of Construction Codes
Licensing Section
P.O. Box 30254
Lansing, MI 48909

Michigan Department of Licensing and Regulatory Affairs
Bureau of Construction Codes
Individual Builder License

ALEXANDER L BRONSON
34 QUEEN ST
MOUNT CLEMENS, MI 48043

License No: Expiration Date:
242000488 05/31/2029

ALEXANDER L BRONSON
34 QUEEN ST
MOUNT CLEMENS, MI 48043

GRETCHEN WHITMER
Governor

Michigan Department of Licensing and Regulatory Affairs
Bureau of Construction Codes
Individual Builder License

ALEXANDER L BRONSON
34 QUEEN ST
MOUNT CLEMENS, MI 48043

MUST BE DISPLAYED IN A CONSPICUOUS PLACE

License No.
242000488

Expiration Date:
05/31/2029

*This document is duly
issued under the laws of the
State of Michigan.*

Michigan Department of Licensing and Regulatory Affairs
Bureau of Construction Codes
Licensing Section
P.O. Box 30254
Lansing, MI 48909

Michigan Department of Licensing and Regulatory Affairs
Bureau of Construction Codes
Company Builder License
Q.O. - ALEXANDER L BRONSON

BLACKOUT CONSTRUCTION LLC
34475 JEFFERSON AVE ATP 2
HARRISON TWP, MI 48045

License No: 262100094 Expiration Date: 05/31/2029

BLACKOUT CONSTRUCTION LLC
34475 JEFFERSON AVE ATP 2
HARRISON TWP, MI 48045

GRETCHEN WHITMER
Governor

**Michigan Department of Licensing and Regulatory Affairs
Bureau of Construction Codes
Company Builder License**

BLACKOUT CONSTRUCTION LLC
34475 JEFFERSON AVE ATP 2
HARRISON TWP, MI 48045

**Qualifying Officer:
ALEXANDER L BRONSON
Qualifying Officer #
242000488**

MUST BE DISPLAYED IN A CONSPICUOUS PLACE

**License No.
262100094**

**Expiration Date:
05/31/2029**

This document is duly
issued under the laws of the
State of Michigan

STATE OF MICHIGAN Valid in U.S. and Canada
NO-FAULT CERTIFICATE OF INSURANCE **INSUREDS COPY**

BRISTOL WEST PREFERRED INSURANCE COMPANY
PO Box 31029, Independence, OH 44131-0029

An authorized Michigan insurer, certifies that it has issued a policy complying with Act 294, P.A. 1972, as amended for the described motor vehicle.

ISSUED TO: ALEXANDER BRONSON
34 QUEEN ST
MOUNT CLEMENS, MI 48043-2336

PENALTY FOR OPERATION WITHOUT INSURANCE

Michigan Law (MCLA 500.3101) requires that the owner or registrant of a motor vehicle registered in this state must have insurance or other approved security for the payment of no-fault benefits on the vehicle at all times. An owner or registrant who drives or permits a vehicle to be driven upon a public highway without the proper insurance or other security is guilty of a misdemeanor. A person convicted of such a misdemeanor shall be fined not less than \$200.00 nor more than \$500.00, imprisoned for not more than 1 year, or both.

POLICY NUMBER	EFFECTIVE DATE	EXPIRATION DATE
G01 6824386 01	02/18/2026	08/18/2026

Note: Coverage from effective to expiration dates is contingent on payments of all amounts when due.

PRODUCER LA INSURANCE AGENCY 311 LLC PHONE:586-954-4690

YEAR	MAKE	MODEL
2013	FORD	ECONOLINE E250 VA CG

VEHICLE IDENTIFICATION NO 1FTNE2EW9DDA24084

A person who supplies false information to the secretary of state under this section or who issues or uses an invalid certificate of insurance is guilty of a misdemeanor punishable by imprisonment for not more than 1 year, or a fine of not more than \$1000, or both.

40018 (02/17) SEE IMPORTANT MESSAGE ON REVERSE SIDE

STATE OF MICHIGAN Valid in U.S. and Canada
NO-FAULT CERTIFICATE OF INSURANCE **SECRETARY OF STATE'S COPY**

BRISTOL WEST PREFERRED INSURANCE COMPANY
PO Box 31029, Independence, OH 44131-0029

An authorized Michigan insurer, certifies that it has issued a policy complying with Act 294, P.A. 1972, as amended for the described motor vehicle.

ISSUED TO: ALEXANDER BRONSON
34 QUEEN ST
MOUNT CLEMENS, MI 48043-2336

PENALTY FOR OPERATION WITHOUT INSURANCE

Michigan Law (MCLA 500.3101) requires that the owner or registrant of a motor vehicle registered in this state must have insurance or other approved security for the payment of no-fault benefits on the vehicle at all times. An owner or registrant who drives or permits a vehicle to be driven upon a public highway without the proper insurance or other security is guilty of a misdemeanor. A person convicted of such a misdemeanor shall be fined not less than \$200.00 nor more than \$500.00, imprisoned for not more than 1 year, or both.

POLICY NUMBER	EFFECTIVE DATE	EXPIRATION DATE
G01 6824386 01	02/18/2026	08/18/2026

Note: Coverage from effective to expiration dates is contingent on payments of all amounts when due.

PRODUCER LA INSURANCE AGENCY 311 LLC PHONE:586-954-4690

YEAR	MAKE	MODEL
2013	FORD	ECONOLINE E250 VA CG

VEHICLE IDENTIFICATION NO 1FTNE2EW9DDA24084

A person who supplies false information to the secretary of state under this section or who issues or uses an invalid certificate of insurance is guilty of a misdemeanor punishable by imprisonment for not more than 1 year, or a fine of not more than \$1000, or both.

40018 (02/17) SEE IMPORTANT MESSAGE ON REVERSE SIDE

WARNING - Keep this certificate in your vehicle at all times. If you fail to produce it upon a police officer's request, you will be responsible for a civil infraction.

If this vehicle is driven by the person(s) named below, residual liability insurance does not apply and the vehicle will be considered uninsured:

KATE AL-HASSAN

WARNING - when a named excluded person operates a vehicle all liability coverage is void - no one is insured. Owners of the vehicle and others legally responsible for the acts of the named excluded person remain fully personally liable.

In the event of a loss, you can submit your loss information 24/7 at www.BristolWest.com or call us Toll-Free during business hours at 1-800-274-7865

For policy information or billing go to www.BristolWest.com

WARNING - Keep this certificate in your vehicle at all times. If you fail to produce it upon a police officer's request, you will be responsible for a civil infraction.

If this vehicle is driven by the person(s) named below, residual liability insurance does not apply and the vehicle will be considered uninsured:

KATE AL-HASSAN

WARNING - when a named excluded person operates a vehicle all liability coverage is void - no one is insured. Owners of the vehicle and others legally responsible for the acts of the named excluded person remain fully personally liable.

In the event of a loss, you can submit your loss information 24/7 at www.BristolWest.com or call us Toll-Free during business hours at 1-800-274-7865

For policy information or billing go to www.BristolWest.com

STATE OF MICHIGAN Valid in U.S. and Canada
NO-FAULT CERTIFICATE OF INSURANCE **INSURED'S COPY**

BRISTOL WEST PREFERRED INSURANCE COMPANY
PO Box 31029, Independence, OH 44131-0029

An authorized Michigan insurer, certifies that it has issued a policy complying with Act 294, P.A. 1972, as amended for the described motor vehicle.

ISSUED TO: ALEXANDER BRONSON
34 QUEEN ST
MOUNT CLEMENS, MI

PENALTY FOR OPERATION WITHOUT INSURANCE

Michigan Law (MCLA 500.3101) requires that the owner or registrant of a motor vehicle registered in this state must have insurance or other approved security for the payment of no-fault benefits on the vehicle at all times. An owner or registrant who drives or permits a vehicle to be driven upon a public highway without the proper insurance or other security is guilty of a misdemeanor. A person convicted of such a misdemeanor shall be fined not less than \$200.00 nor more than \$500.00, imprisoned for not more than 1 year, or both.

POLICY NUMBER	EFFECTIVE DATE	EXPIRATION DATE
G01 6824386 01	02/18/2026	08/18/2026

Note: Coverage from effective to expiration dates is contingent on payments of all amounts when due.

PRODUCER LA INSURANCE AGENCY 311 LLC PHONE:586-954-4690

YEAR	MAKE	MODEL
2019	CHEVROLET	TRAX 1LT UT

VEHICLE IDENTIFICATION NO 3GNCJLSBXXL334513

A person who supplies false information to the secretary of state under this section or who issues or uses an invalid certificate of insurance is guilty of a misdemeanor punishable by imprisonment for not more than 1 year, or a fine of not more than \$1000, or both.

40018 (02/17) SEE IMPORTANT MESSAGE ON REVERSE SIDE

STATE OF MICHIGAN Valid in U.S. and Canada
NO-FAULT CERTIFICATE OF INSURANCE **SECRETARY OF STATE'S COPY**

BRISTOL WEST PREFERRED INSURANCE COMPANY
PO Box 31029, Independence, OH 44131-0029

An authorized Michigan insurer, certifies that it has issued a policy complying with Act 294, P.A. 1972, as amended for the described motor vehicle.

ISSUED TO: ALEXANDER BRONSON
34 QUEEN ST
MOUNT CLEMENS, MI

PENALTY FOR OPERATION WITHOUT INSURANCE

Michigan Law (MCLA 500.3101) requires that the owner or registrant of a motor vehicle registered in this state must have insurance or other approved security for the payment of no-fault benefits on the vehicle at all times. An owner or registrant who drives or permits a vehicle to be driven upon a public highway without the proper insurance or other security is guilty of a misdemeanor. A person convicted of such a misdemeanor shall be fined not less than \$200.00 nor more than \$500.00, imprisoned for not more than 1 year, or both.

POLICY NUMBER	EFFECTIVE DATE	EXPIRATION DATE
G01 6824386 01	02/18/2026	08/18/2026

Note: Coverage from effective to expiration dates is contingent on payments of all amounts when due.

PRODUCER LA INSURANCE AGENCY 311 LLC PHONE:586-954-4690

YEAR	MAKE	MODEL
2019	CHEVROLET	TRAX 1LT UT

VEHICLE IDENTIFICATION NO 3GNCJLSBXXL334513

A person who supplies false information to the secretary of state under this section or who issues or uses an invalid certificate of insurance is guilty of a misdemeanor punishable by imprisonment for not more than 1 year, or a fine of not more than \$1000, or both.

40018 (02/17) SEE IMPORTANT MESSAGE ON REVERSE SIDE

WARNING - Keep this certificate in your vehicle at all times. If you fail to produce it upon a police officer's request, you will be responsible for a civil infraction.

If this vehicle is driven by the person(s) named below, residual liability insurance does not apply and the vehicle will be considered uninsured:

KATE AL-HASSAN

WARNING - when a named excluded person operates a vehicle all liability coverage is void - no one is insured. Owners of the vehicle and others legally responsible for the acts of the named excluded person remain fully personally liable.

In the event of a loss, you can submit your loss information 24/7 at www.BristolWest.com or call us Toll-Free during business hours at 1-800-274-7865

For policy information or billing go to www.BristolWest.com

WARNING - Keep this certificate in your vehicle at all times. If you fail to produce it upon a police officer's request, you will be responsible for a civil infraction.

If this vehicle is driven by the person(s) named below, residual liability insurance does not apply and the vehicle will be considered uninsured:

KATE AL-HASSAN

WARNING - when a named excluded person operates a vehicle all liability coverage is void - no one is insured. Owners of the vehicle and others legally responsible for the acts of the named excluded person remain fully personally liable.

In the event of a loss, you can submit your loss information 24/7 at www.BristolWest.com or call us Toll-Free during business hours at 1-800-274-7865

For policy information or billing go to www.BristolWest.com



GRETCHEN WHITMER
GOVERNOR

STATE OF MICHIGAN
DEPARTMENT OF HEALTH AND HUMAN SERVICES
LANSING

ELIZABETH HERTEL
DIRECTOR

April 30, 2026

Dear Lead Professional:

Your application for certification as a Lead Professional with the Michigan Department of Health and Human Services, Lead Certification and Compliance Assurance Section (LCCA) has been approved.

This certification is issued to you as evidence that you have met or exceeded the minimum requirements of the Michigan Lead Abatement Act for the discipline indicated, have successfully passed the certification examination, and have paid the appropriate fees. The enclosed lead certification card is valid until **March 31, 2027**, whereupon the annual fee and application are due. Failure to supply the fee and application by the appropriate date will result in a late penalty. Your certification card must be present with you at any site where you are conducting lead-based paint activities.

Training certification is valid for a period of three (3) years, at which time a refresher training class is required for your discipline(s). You can find a list of accredited training providers and refresher classes at: www.michigan.gov/leadsafe

As you agreed to on the Lead Professional Certification Application, compliance with all applicable federal, state, and local regulations, ordinances, guidelines, and laws remains a condition of certification. Violations may result in suspension or revocation of certification, and or citation and administrative fine. If you have any questions regarding lead-based paint activities, please contact our office at (517) 335-9390.

Congratulations on your certification,

A handwritten signature in black ink, appearing to read "T. Mata".

Thomas Mata
Certification Analyst

Encl: *Lead Professional Certification Card*



ALEXANDER BRONSON
LEAD ABATEMENT SUPERVISOR

P-011035

**ANNUAL FEE
DUE:
03/31/27**

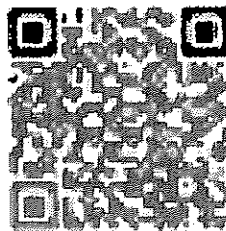

**TRAINING &
EXAM DUE:
03/31/29**

**LEAD CERTIFICATION AND
COMPLIANCE ASSURANCE SECTION**



CERTIFICATE OF COMPLETION

This certifies that

Alexander L Bronson

has successfully completed the course

OSHA 10 Hour Outreach Training Program - Construction

CEUs 1.0

Credit Hours 10.00

Completion Date 04/10/2026

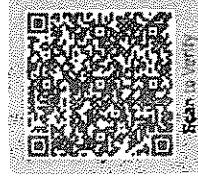
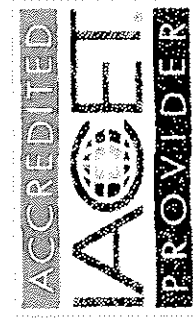

Jason Cole, Trainer C 26-0113289 and G 26-0084457

"As an OSHA Outreach Training Program trainer, I affirm that I have conducted this OSHA Outreach Training Program training class in accordance with OSHA Outreach Training Program requirements. I will document this class to my OSHA Authorizing Training Organization. Upon successful review of my documentation, I will provide each student their course completion card within 90 calendar days of the end of the class."

"As an IACET Accredited Provider, 360training.com, Inc. offers IACET CEUs for its learning events that comply with the ANSI/IACET Continuing Education and Training Standard."

THIS CERTIFICATE IS NON-TRANSFERABLE



BLACKOUT CONSTRUCTION LLC

Unique Entity ID HGYKC84KLWL5	CAGE / NCAGE 20ML7	Purpose of Registration All Awards
Registration Status Active Registration	Expiration Date May 14, 2027	
Physical Address 34 Queen ST Mount Clemens, Michigan 48043-2336 United States	Mailing Address 34 Queen ST Mount Clemens, Michigan 48043-2336 United States	

Business Information

Doing Business as BLACKOUT CONSTRUCTION LLC	Division Name (blank)	Division Number (blank)
Congressional District Michigan 10	State / Country of Incorporation (blank) / (blank)	URL (blank)

Registration Dates

Activation Date May 27, 2026	Submission Date May 14, 2026	Initial Registration Date May 14, 2026
--	--	--

Entity Dates

Entity Start Date Aug 25, 2020	Fiscal Year End Close Date Dec 31
--	---

Immediate Owner

CAGE (blank)	Legal Business Name (blank)
------------------------	---------------------------------------

Highest Level Owner

CAGE (blank)	Legal Business Name (blank)
------------------------	---------------------------------------

Executive Compensation

Registrants in the System for Award Management (SAM) respond to the Executive Compensation questions in accordance with Section 6202 of P.L. 110-252, amending the Federal Funding Accountability and Transparency Act (P.L. 109-282). This information is not displayed in SAM. It is sent to USApending.gov for display in association with an eligible award. Maintaining an active registration in SAM demonstrates the registrant responded to the questions.

Proceedings Questions

Registrants in the System for Award Management (SAM.gov) respond to proceedings questions in accordance with FAR 52.209-7, FAR 52.209-9, or 2. C.F.R. 200 Appendix XII. Their responses are displayed in the responsibility/qualification section of SAM.gov. Maintaining an active registration in SAM.gov demonstrates the registrant responded to the proceedings questions.

Exclusion Summary

Active Exclusions Records?

No

SAM Search Authorization

I authorize my entity's non-sensitive information to be displayed in SAM public search results:

Yes

Entity Types

Business Types

Entity Structure Partnership or Limited Liability Partnership	Entity Type Business or Organization	Organization Factors Limited Liability Company
Profit Structure For Profit Organization		

Socio-Economic Types

Minority-Owned Business
Hispanic American Owned

Check the registrant's Reqs & Certs, if present, under FAR 52.212-3 or FAR 52.219-1 to determine if the entity is an SBA-certified HUBZone small business concern. Additional small business information may be found in the SBA's Dynamic Small Business Search if the entity completed the SBA supplemental pages during registration.

Financial Information

Accepts Credit Card Payments Yes	Debt Subject To Offset No
EFT Indicator 0000	CAGE Code 20ML7

Points of Contact

Electronic Business
 Alexander L Bronson, Owner **34 Queen ST**
Mount Clemens, Michigan 48043
United States

Government Business
 Alexander L Bronson, Owner **34 Queen ST**
Mount Clemens, Michigan 48043
United States

Service Classifications

NAICS Codes

Primary	NAICS Codes	NAICS Title
Yes	236115	New Single-Family Housing Construction (Except For-Sale Builders)

Disaster Response

Yes, this entity appears in the disaster response registry.
 No, this entity does not require bonding to bid on contracts.

Bonding Levels	Dollars
	(blank)

States Michigan	Counties (blank)	Metropolitan Statistical Areas (blank)
---------------------------	----------------------------	--



27983875



STATE OF MICHIGAN
CSCL/CD- 2700 - DOMESTIC LIMITED LIABILITY
COMPANY ANNUAL STATEMENT

Corporations Division Administrator

FILED

Doc #: 27983875
Filed Date: 2/2/2026

C0665-9661 02/02/2026 Received by Michigan Corporations Division

DEPARTMENT OF LICENSING AND REGULATORY AFFAIRS LIMITED LIABILITY COMPANY ANNUAL STATEMENT <i>Required by Section 207, Act 23, Public Act of 1993</i>		
Limited Liability Company Information		
The present name of the limited liability company is:	BLACKOUT CONSTRUCTION LLC	
The identification number assigned by the Bureau is:	802511476	
Filing Year	2026	
The name of the resident agent at the registered office is: ALEX BRONSON		
Address 34 QUEEN ST, MOUNT CLEMENTS, MI 48043		
Mailing Address 34 QUEEN ST, MOUNT CLEMENTS, MI 48043		
Attestations		
<input checked="" type="checkbox"/> I understand that the information I enter into the online system is public information and will appear online and on copy requests exactly as I enter it into the system.		
<input checked="" type="checkbox"/> I have been authorized by the business entity to file this document online.		
<input checked="" type="checkbox"/> I, HEREBY SWEAR AND/OR AFFIRM, under penalty of law, including criminal prosecution, that the facts contained in this document are true. I certify that I am signing this document as the person(s) whose signature is required, or as an agent of the person(s) whose signature is required, who has authorized me to place his/her signature on this document.		
Signature		
<i>Self</i>	<i>Alex Bronson</i>	<i>02/02/2026</i>
Signer's Capacity	Sign Here	Date



Division of Community & Economic Development

Sheldon Neeley Mayor

Good Standing Certification

Applicant and/or Business Clearance

All applicants for City of Flint funded programs, including federal programs, must remain current and not in default on any obligations related to taxes, fines, penalties, water service, licenses or other forms of penalties.

APPLICANT NAME: Blackout Construction LLC

HOME ADDRESS:

DBA:

BUSINESS ADDRESS: 34 Queen St. Mount Clemens MI 48043

Please include addresses of all properties in the name of other current and/or former businesses, parent company, subsidiaries and/or divisions. Also, please include all former names used while conducting business with the City.

This section to be completed by the Department of Finance - Customer Service Div.

Please check the following divisions for the status of current and delinquent obligations owed to the City of Flint. Please circle the appropriate response for each division.

WATER DIV.	CURRENT	DELINQUENT	<i>No water acct located</i>
PROPERTY TAXES DIV.	CURRENT	DELINQUENT	<i>NO Prop tax located</i>
INCOME TAX DIV.	CURRENT	DELINQUENT	<i>No City tax record</i>
ENFORCEMENT	CURRENT	DELINQUENT	
MR	CURRENT	DELINQUENT	<i>No MR located</i>

This section to be completed by the Department of Community and Economic Development

DCED/EDC: CURRENT DELINQUENT N/A (108 Loans, EDC loans, mortgage repayments, etc.)

City of Flint DCED Representative and Date

If delinquencies exist, please indicate the date, type and amount of obligation:

Blank lines for listing delinquencies.

Shelby Bader 2/6/2026 DCED Staff Person and Date

Signature of Shelby Bader, 5-8-2026, City of Flint Customer Serv. Representative and Date



27684152



STATE OF MICHIGAN
 CSCL/CD- 770_771 - CERTIFICATE OF
 RESTORATION OF GOOD STANDING

Corporations Division Administrator

FILED

Doc #: 27684152
 Filed Date: 12/9/2025

C0603-3063 12/08/2025 Received by Michigan Corporations Division

DEPARTMENT OF LICENSING AND REGULATORY AFFAIRS CERTIFICATE OF RESTORATION OF GOOD STANDING <i>Pursuant to the provisions of Act 23, Public Acts of 1993, the undersigned limited liability company executes the following Certificate:</i>								
The present name of the limited liability company is: The identification number assigned by the Bureau is: Limited Liability Company Type:	BLACKOUT CONSTRUCTION LLC 802511476 Domestic Limited Liability Company							
The name of the resident agent at the registered office is: ALEX BRONSON Address 34 QUEEN ST, MOUNT CLEMENTS, MI 48043 Mailing Address 34 QUEEN ST, MOUNT CLEMENTS, MI 48043								
Annual Statements The limited liability company states that the certificate is accompanied by the annual statements and applicable fees for all the years for which statements were not filed and fees were not paid.								
<table border="1" style="width: 100%; border-collapse: collapse;"> <thead> <tr> <th style="width: 70%;">I acknowledge I am filing the Annual Statement for the year listed below.</th> <th style="width: 30%;">Missing Annual Statement Filing Year</th> </tr> </thead> <tbody> <tr> <td><input checked="" type="checkbox"/> I acknowledge I am filing the Annual Statement for the year listed below.</td> <td style="text-align: center;">2023</td> </tr> <tr> <td><input checked="" type="checkbox"/> I acknowledge I am filing the Annual Statement for the year listed below.</td> <td style="text-align: center;">2025</td> </tr> </tbody> </table>		I acknowledge I am filing the Annual Statement for the year listed below.	Missing Annual Statement Filing Year	<input checked="" type="checkbox"/> I acknowledge I am filing the Annual Statement for the year listed below.	2023	<input checked="" type="checkbox"/> I acknowledge I am filing the Annual Statement for the year listed below.	2025	
I acknowledge I am filing the Annual Statement for the year listed below.	Missing Annual Statement Filing Year							
<input checked="" type="checkbox"/> I acknowledge I am filing the Annual Statement for the year listed below.	2023							
<input checked="" type="checkbox"/> I acknowledge I am filing the Annual Statement for the year listed below.	2025							
Filing Effective Date The filing will be effective: _____ when filed by the Corporations Division Administrator.								
Attestations <input checked="" type="checkbox"/> I understand that the information I enter into the online system is public information and will appear online and on copy requests exactly as I enter it into the system. <input checked="" type="checkbox"/> I have been authorized by the business entity to file this document online. <input checked="" type="checkbox"/> I, HEREBY SWEAR AND/OR AFFIRM, under penalty of law, including criminal prosecution, that the facts contained in this document are true. I certify that I am signing this document as the person(s) whose signature is required, or as an agent of the person(s) whose signature is required, who has authorized me to place his/her signature on this document.								
Signature(s) This document must be signed by a member, manager, or an authorized agent:								
<i>Self</i> _____ Signer's Capacity	<i>Alex Bronson</i> _____ Sign Here	<i>12/08/2025</i> _____ Date						

BLACKOUT CONSTRUCTION LLC



<i>Entity Name</i>	BLACKOUT CONSTRUCTION LLC
<i>Identification #</i>	802511476
<i>Jurisdiction</i>	Michigan
<i>Entity Type</i>	Domestic Limited Liability Company
<i>Entity Status</i>	Active
<i>AR Standing</i>	Good
<i>AR Due Date</i>	02/15/2027
<i>Initial Filing Date</i>	08/25/2020
<i>Resident Agent Name</i>	ALEX BRONSON
<i>Registered Office Street Address</i>	34 QUEEN ST, MOUNT CLEMENTS, MI 48043
<i>Registered Office Mailing Address</i>	34 QUEEN ST, MOUNT CLEMENTS, MI 48043
<i>Management Type</i>	Member



**View History &
Filings**

260222

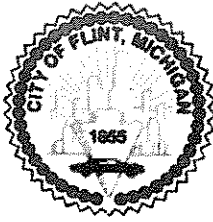

RESOLUTION NO.: _____

PRESENTED: 6-17-2026

ADOPTED: _____

A0661

BY THE CITY ADMINISTRATOR:

RESOLUTION AUTHORIZING ACCEPTANCE OF THE FY26 ONE-TIME ENHANCEMENT GRANT FROM THE MICHIGAN DEPARTMENT OF LABOR AND ECONOMIC OPPORTUNITY(LEO) FOR IMPROVEMENTS TO THE HASKELL COMMUNITY CENTER

WHEREAS, the City of Flint applied for funding through the Michigan Department of Labor and Economic Opportunity's FY26 One-Time Enhancement Grant Program to support improvements to the Haskell Community Center located at 2201 Forest Hill Avenue in Flint, Michigan; and

WHEREAS, the proposed project includes completion of Phases 2 through 4 of the Haskell Community Center roof replacement project, elevator repair and modernization, and related improvements intended to stabilize the facility, improve accessibility, and support future community programming; and

WHEREAS, the Michigan Department of Labor and Economic Opportunity has awarded the City of Flint Grant No. E20260096 in the amount of Five Hundred Thousand Dollars (\$500,000) for the period of October 1, 2025 through September 30, 2030; and

WHEREAS, acceptance of this grant will assist the City in preserving and improving a valuable public facility while enhancing accessibility and expanding opportunities for community use and youth programming; and

WHEREAS, grant funds shall be expended in accordance with the approved budget and scope of work approved by the Michigan Department of Labor and Economic Opportunity.

THEREFORE, IT IS RESOLVED that the appropriate City officials are hereby authorized to do all things necessary including executing any necessary agreements, to accept the Michigan Department of Labor and Economic Opportunity FY26 One-Time Enhancement Grant Program award, Grant No. E20260096, in the amount of \$500,000, for capital improvements at Haskell Community Center.

IT IS ALSO RESOLVED that the FY26 budget shall, upon adoption of this resolution, be amended to appropriate grant revenues and expenditures.

IT IS FURTHER RESOLVED that the FY27 and all subsequent fiscal years for as long as grant funds remain shall be amended as necessary to appropriate remaining grant expenditures and revenues.

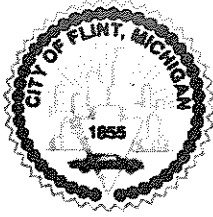

RESOLUTION NO.: _____

PRESENTED: _____

ADOPTED: _____

APPROVED AS TO FORM:



JoAnne Gurley (Jun 4, 2026 16:32:17 EDT)

JoAnne Gurley, City Attorney

APPROVED AS TO FINANCE:



Phillip Moore, Chief Financial Officer

FOR THE CITY OF FLINT:



Clyde Edwards/ A0661 (Jun 5, 2026 16:45:44 EDT)

Clyde Edwards, City Administrator

APPROVED BY CITY COUNCIL:



STAFF REVIEW FORM

Effective: April 1, 2026

(Do not alter or modify this form without written permission from the City Administrator)

TODAY'S DATE: 5/26/2026

BID PROPOSAL #: _____

AGENDA ITEM TITLE: FY26 ONE TIME ENHANCEMENT GRANT ACCEPTANCE RESOLUTION

PREPARED BY: Christian Baldwin – Grants Management Officer

VENDOR NAME: State of Michigan Department of Labor and Economic Opportunity (LEO)

Section 1. BACKGROUND/SUMMARY OF PROPOSED ACTION..

Vendor Compliance (This vendor has been properly vetted and the responses are below) :

Federal gov't	(All documentation current, no violations)	<input type="checkbox"/> YES	<input type="checkbox"/> NO
State gov't	(All documentation current, no violations)	<input type="checkbox"/> YES	<input type="checkbox"/> NO
City of Flint	(All documentation current, no violations)	<input type="checkbox"/> YES	<input type="checkbox"/> NO

The requesting authority is validating that this vendor has been in full compliance with all past contract provisions and has not violated the terms of any contract with the City of Flint.

NOTE: Preparer **MUST** include a response to the conditions below:

- Did we do an assessment of first consideration to internal City of Flint staff and resources (explain)?
- Why was this vendor chosen?
- What history does this vendor have with the City of Flint?
- What steps will be taken to do a post-performance of the vendor?

Background

The City of Flint applied for and has been awarded a \$500,000 grant through the Michigan Department of Labor and Economic Opportunity's (LEO) FY26 One-Time Enhancement Grant Program. The grant will support critical capital improvements to the Haskell Community Center located at 2201 Forest Hill Avenue. The grant period extends from October 1, 2025 through September 30, 2030. No local match is required.

The Haskell Community Center has experienced significant deferred maintenance due to prolonged municipal funding constraints. The facility's most pressing need is replacement of the existing roof system, which has deteriorated to the point that continued water intrusion threatens the structural integrity of the building and limits the City's ability to invest in interior improvements. According to publicly solicited cost estimates, full replacement of the roof exceeds \$600,000. The City has already committed approximately \$200,000 in local funding toward Phase 1 of the project. Grant funding will allow the City to complete Phases 2 through 4 of the roof replacement project and fully stabilize the building envelope.

In addition to roof replacement, the grant will fund repairs and modernization of the facility's elevator system. Elevator improvements are intended to restore reliable operation, improve accessibility, and ensure compliance with the Americans with Disabilities Act (ADA), allowing all residents to access the facility regardless of mobility limitations.



STAFF REVIEW FORM

Effective: April 1, 2026

(Do not alter or modify this form without written permission from the City Administrator)

The approved project budget consists of:

Roof Replacement (Phases 2–4): \$400,000
 Elevator Repair and Modernization: \$100,000
 Total Grant Award: \$500,000

Upon completion, the project will provide a structurally sound and ADA-accessible community facility capable of supporting expanded youth, recreation, and community programming. The application identifies the Haskell Community Center as the future operational home of the Flint Police Athletic League (PAL), supporting youth mentorship, recreation, and community engagement activities.

PROCUREMENT (MUST BE SPECIFIED)

Please specify how this vendor was identified: (Check one)

- Sole Source (Please attach sole source statement to requisition)
- Competitive Bid Process (Please attach bid tabulation/documents to requisition)
- Cooperative Contract (MIDeal, Sourcewell, GSA, or other municipality)
 *Contract must be attached to your requisition and contract must appear on the vendor's quote for goods/services
- (3) Quotes (please attach all quotes to your requisition)

Section 2. PREVIOUS ALLOCATIONS (INCLUDE ALL ACCOUNTS USED FOR THIS PURPOSE)// PROVIDE RESOLUTION OR CONTRACT INFORMATION THAT APPLIES..

Fiscal Year	Account	PO Number	FY PO Amount	FY Expensed	Resolution



STAFF REVIEW FORM

Effective: April 1, 2026

(Do not alter or modify this form without written permission from the City Administrator)

[Empty rectangular box for staff review]

Section 3. POSSIBLE BENEFIT TO THE CITY OF FLINT (RESIDENTS AND/OR CITY OPERATIONS) INCLUDE PARTNERSHIPS AND COLLABORATIONS..

Approval of this resolution will allow the City of Flint to secure \$500,000 in State of Michigan funding to complete critical improvements to the Haskell Community Center without requiring a local match. The project will address significant deferred maintenance by completing the remaining phases of the facility's roof replacement and modernizing the building's elevator system, protecting a valuable public asset from further deterioration while improving accessibility for residents. These improvements will enhance the City's ability to provide safe, ADA-accessible recreational, educational, and community programming opportunities for youth, families, seniors, and individuals with disabilities. The project also supports the City's partnership with the Flint Police Athletic League (PAL), which intends to utilize the facility for youth development, mentorship, and community engagement activities. By preserving and improving the Haskell Community Center, the project strengthens neighborhood resources, expands community programming opportunities, and reduces the likelihood of more costly repairs in the future.

Section 4. FINANCIAL IMPLICATIONS..

IF ARPA related Expenditure:

Has this request been reviewed by E&Y Firm: YES NO IF NO, PLEASE EXPLAIN:

NOTE: Accountant MUST include the following information:

- What is the total amount budgeted for this purpose?
- What percentage is being spent with this vendor?
- What is the justification for spending this amount of money with this vendor?
- What percentage is being spent out of each line item used in this request?
- List all the known budgeted funds from that line item.



STAFF REVIEW FORM

Effective: April 1, 2026

(Do not alter or modify this form without written permission from the City Administrator)

Financial Impact

The grant award totals \$500,000. No local match is required. Grant revenues and expenditures will be appropriated upon adoption of the resolution. Any remaining grant funds will be carried forward and appropriated in FY27 and subsequent fiscal years as necessary until the grant is fully expended and closed.

The approved project budget consists of:

Professional Services (GL# and grant code pending): Roof Replacement (Phases 2-4): \$400,000
Professional Services (GL# and grant code pending): Elevator Repair and Modernization: \$100,000
Total Grant Award: \$500,000

BUDGETED EXPENDITURE? YES NO IF NO, PLEASE EXPLAIN:

Dept.	Name of Account	Account Number	Grant CODE	Amount
Mayor/Facilities	Professional Services	TBD	TBD	\$500,000
FY26 GRAND TOTAL				\$500,000

WHEN APPLICABLE, IF MORE THAN ONE (1) YEAR, PLEASE ESTIMATE TOTAL AMOUNT FOR EACH BUDGET YEAR: (This will depend on the term of the bid proposal)

BUDGET YEAR 1: _____

BUDGET YEAR 2: _____

BUDGET YEAR 3: _____

OTHER IMPLICATIONS (i.e., collective bargaining).. _____

PRE-ENCUMBERED? YES NO REQUISITION NO: _____

ACCOUNTING APPROVAL: JoJasisk (May 27, 2026 13:43:59 EDT) Date: 05/27/2026

WILL YOUR DEPARTMENT NEED A CONTRACT? YES NO

Section 5. RESOLUTION DEFENSE TEAM..



STAFF REVIEW FORM

Effective: April 1, 2026

(Do not alter or modify this form without written permission from the City Administrator)

(Place the names of those who can defend this resolution at City Council)

	NAME	PHONE NUMBER
1		
2		
3		
4		

STAFF RECOMMENDATION: (PLEASE SELECT): APPROVED NOT APPROVED

DEPARTMENT HEAD SIGNATURE: 
 Christian Baldwin (May 27 2026 13 44 37 EDT)
 (Name, Title)

ADMINISTRATION APPROVAL: 
 Clyde Edwards (May 27 2026 16 02 26 EDT)
 (\$20,000 or above spending authorizations)

Section 6. VENDOR EVALUATION..

Business Title: _____ Vendor ID: _____

Review Period: _____ Department: _____

Project Name: _____ Project Type: _____

Vendor Goals:

1 = Poor 2 = Fair 3 = Sufficient 4 = Good 5 = Excellent



STAFF REVIEW FORM

Effective: April 1, 2026

(Do not alter or modify this form without written permission from the City Administrator)

Job Knowledge:	<input type="checkbox"/>	<input type="checkbox"/>	<input type="checkbox"/>	<input type="checkbox"/>	<input type="checkbox"/>
Work Quality:	<input type="checkbox"/>	<input type="checkbox"/>	<input type="checkbox"/>	<input type="checkbox"/>	<input type="checkbox"/>
Timeliness:	<input type="checkbox"/>	<input type="checkbox"/>	<input type="checkbox"/>	<input type="checkbox"/>	<input type="checkbox"/>
Compliance with Contract:	<input type="checkbox"/>	<input type="checkbox"/>	<input type="checkbox"/>	<input type="checkbox"/>	<input type="checkbox"/>
Warranty (If Product):	<input type="checkbox"/>	<input type="checkbox"/>	<input type="checkbox"/>	<input type="checkbox"/>	<input type="checkbox"/>
Responsiveness:	<input type="checkbox"/>	<input type="checkbox"/>	<input type="checkbox"/>	<input type="checkbox"/>	<input type="checkbox"/>
Cost Effectiveness:	<input type="checkbox"/>	<input type="checkbox"/>	<input type="checkbox"/>	<input type="checkbox"/>	<input type="checkbox"/>
Dependability:	<input type="checkbox"/>	<input type="checkbox"/>	<input type="checkbox"/>	<input type="checkbox"/>	<input type="checkbox"/>
Total Performance:	<input type="checkbox"/>	<input type="checkbox"/>	<input type="checkbox"/>	<input type="checkbox"/>	<input type="checkbox"/>
Overall Rating:	<input type="checkbox"/>	<input type="checkbox"/>	<input type="checkbox"/>	<input type="checkbox"/>	<input type="checkbox"/>

DEFECTS (IF ANY): IF CHECKED, PLEASE EXPLAIN:

Performance / Other Comments:

REVIEWER'S SIGNATURE: _____

Date: _____

GRANT AGREEMENT BETWEEN
MICHIGAN DEPARTMENT OF LABOR AND ECONOMIC OPPORTUNITY
hereinafter referred to as the "Department"
AND
City of Flint
hereinafter referred to as the "Grantee"

GRANTEE/ADDRESS:

Name: Clyde Edwards
Title: Administrator
Address: 1101 S.Saginaw St., Flint, MI 48502
Phone: (810) 766-7346 x 204

GRANT ADMINISTRATOR/ADDRESS:

Contact Name: Amber Covington
Organizational Unit: Department of Labor and Economic Opportunity, State of Michigan
Address: Elliott-Larsen Building, 6th Floor, 320 S. Walnut St. Lansing, MI 48933
Telephone Number: (517) 388-0567

GRANT PERIOD:

This Agreement will begin on 10/01/2025 and continue through 09/30/2030. No activity will be performed, and the Department will not assume any responsibility or liability for costs incurred by the Grantee prior to the start date of this Agreement. This Agreement is in full force and effect for the period specified.

TOTAL AUTHORIZED BUDGET: \$500,000.00

State Contribution: \$500,000.00
Match Contribution: \$0.00

ACCOUNTING DETAIL:

Assistance Listing # (ALN):
Grantee's Unique Entity Identifier: G2XMHBKX5
Federal ID: 38-6004611

RECIPIENT RELATIONSHIP IN GRANT AGREEMENT:

- Sub-recipient Vendor Recipient

Special Conditions:

- A. This Agreement is valid upon approval and execution by the Department which may be contingent upon approval by the State Administrative Board and signature by the Grantee.
- B. This Agreement is conditionally approved subject to and contingent upon the availability of funds.
- C. Based on the availability of funding, the Department may specify the amount of funding the Grantee may expend during a specific time period within the Agreement Period.
- D. The Department will not assume any responsibility or liability for costs incurred by the Grantee prior to the start date of this Agreement.
- E. The Grantee is required by 2004 PA 533 to receive payments by electronic funds transfer.
- F. The Grantee agrees that all procurement transactions involving the use of state funds in excess of \$5,000 must be conducted in a manner that provides maximum open and free competition i.e receiving multiple bids, quotes, and proposals to buy comparable goods and services. When competitive selection is not feasible or practical, the Grantee agrees to obtain the written approval of the Department before making a sole source selection. Sole source contracts should be negotiated to the extent that such negotiation is possible.

This is Grant # E20260096 between the Michigan Department of Labor and Economic Opportunity (Department), and City of Flint (Grantee), subject to terms and conditions of this grant agreement (Agreement).

Part I: AGREEMENT PROVISIONS

Agreement Scope: The Grantee agrees to comply with all terms and conditions of this grant Agreement, including any schedules and attachments that are incorporated by reference into the Agreement.

Agreement Amount: The total amount of this Agreement is \$500,000.00. Under the terms of this Agreement, the Department will provide funding not to exceed \$500,000.00.

Agreement Approval: This Agreement is conditionally approved subject to and contingent upon the availability of funds. This Agreement becomes valid upon approval and execution by the Department, which may be contingent upon approval by the State Administrative Board and signature by the Grantee.

1.0 Statement of Purpose

The purpose of the program is to fund the following State of Michigan budget appropriation:

Sec. 454 (15) From the funds appropriated in part 1 for legislatively directed spending items, \$500,000.00 must be awarded to the city of Flint in Genesee County to support improvements to the Haskell Community Center

1.1 Statement of Work

The Grantee agrees to undertake, perform, and complete the following project:

These services are specifically described in the Grantee's Proposal, Attachment A.

1.2 Detailed Budget

A. The Budget is incorporated into this Agreement as attachment B. The Grantee agrees that all funds shown in the Budget are to be spent as detailed in the Budget. The Grantee is prohibited from spending funds for "lobbying" and related activities as defined in MCL 4.415. Other prohibited expenses include:

- Lobbying / Political Activities
- Court fees/costs
- Contributions and donations
- Fines and penalties
- Legislative expenses
- Entertainment expenses
- Fundraising costs, including costs of hosting events
- Cash reserves and endowment contributions
- Alcoholic beverages
- Sales tax for non-profit and governmental entities
- Goods and services for personal use
- Expenses outside of budgeted items
- Any other expenses LEO determines are ineligible

B. This Agreement does not commit the State of Michigan (State) or the

Department of Labor and Economic Opportunity (LEO) to approve requests for additional funds at any time.

- C. If applicable, Grantee will be reimbursed for travel costs including mileage, meals, and lodging, that are budgeted, incurred, and related to project activities provided under this Agreement.

1. If the Grantee has a documented policy related to travel reimbursement for employees, the Department will reimburse the Grantee for travel costs at the Grantee's documented reimbursement rate for employees. Otherwise, the state of Michigan travel reimbursement rate applies.

2. Federally funded Grantees must comply with Title 2 CRF 200.475.

3. State of Michigan travel rates may be found at the following website:https://www.michigan.gov/dtmb/0,5552,7-358-82548_13132---,00.html ,

4. International travel must be preapproved by the Department and itemized in the budget.

- D. A deviation allowance greater than 5% of the budget category amount will be allowed only with a formal grant amendment that must be signed by both the Grantor and Grantee.

A deviation allowance that is less than 5% is allowable without Department approval provided that they do not authorize new categories, subcontracts, equipment items, or positions not shown in the attached Program Budget Summary and supporting detail schedules.

1.3 Funding

Based on the availability of funding, the Department may specify the amount of funding the Grantee may expend during a specific time within the Agreement Period.

1.4 Amendments

- A. Amendments to the Budget or workplan will be valid only upon prior review by and written approval from the Department.
- B. Any amendment to this Agreement will be valid only if made in writing and executed by all parties to this Agreement.
- C. Any amendment proposed by the Grantee that would affect the Department's funding of any project must be submitted in writing to the Department immediately upon determining the need for such change.
- D. The Department has sole discretion to approve or deny an amendment request.
- E. Upon the Department's request and receipt of a proposed amendment, the Grantee must amend this Agreement.

1.5 Payment and Reimbursements

The maximum amount of grant funding is \$500,000.00 (Five Hundred Thousand and 00/100)

- A. Payments may be made upon submission of Grantee Financial Status Report (FSR) requests in EGrAMS <http://egramsmi.com/leo> indicating grant funds received to date, project expenditures to date (supported with computer printouts of accounts, general ledger sheets, balance sheets, etc.), and objectives completed to date. Backup documentation such as computer printouts of accounts, ledger sheets, check copies, etc. must be maintained for audit purposes for the full length of the Department's retention schedule, to comply with this Agreement.
- B. The Grantee representative who submits the FSR is certifying to the best of their knowledge and belief that the report is true, complete, and accurate and the expenditures, disbursements, and cash receipts are for the purposes and objectives set forth in the terms and conditions of this Agreement. Costs incurred engaging in lobbying activities, as defined in MCL 4.415(2), are not permitted or considered a reimbursable cost. The Grantee representative submitting the FSR should be aware that any false, fictitious, or fraudulent information, or the omission of any material facts, may subject them to criminal, civil, or administrative penalties for fraud, false statements, false claims, or other bases for liability or guilt.
- C. FSRs must be submitted no later than 30 calendar days after the close of each month. The monthly FSRs must reflect total actual program expenditures up to the total agreement amount. Grantee's failure to meet financial reporting responsibilities as identified in this Agreement may result in the Department withholding future payments.
- D. The payment of the final grant amount will be made after completion of the project and after the Department has received and approved a final report, if applicable. The final payment is also contingent upon the submission of a final invoice that includes expenditures of grant funds reported by line item and compared to the approved Budget.
- E. The Grantee is required by section 283a of the Management and Budget Act, MCL 18.1283a, to receive payments by electronic funds transfer.
- F. Operational Advance: Operational Advances require prior approval from Department. Specific Terms of the operational advance are included in Attachment E once the Department approves Public Act 279 of 1894, MCL 17.52 states that the state shall take all steps necessary to assure that payment for goods or services, is mailed within 45 days after receipt of the goods or services, a complete invoice for goods or services, or a complete contract for goods or services, whichever is later.
- G. Reimbursement Mechanism
All Grantees must register using the on-line vendor self-service site to receive all state of Michigan payments as Electronic Funds Transfers (EFT)/Direct

Deposits, as mandated by MCL 18.1283a. Vendor registration information is available through the Department of Technology, Management and Budget's web site: <https://www.michigan.gov/sigmavss>.

H. **Unobligated Funds**

Any unobligated balance of funds held by the Grantee at the end of the Agreement period will be returned to the Department within 30 days of the end of the Agreement unless the Department instructs otherwise.

I. **Indirect Costs**

The Grantee may use an approved federal or state indirect rate in their budget calculations and financial status reporting. If the Grantee does not have an existing approved federal or state indirect rate, they may use a 15% de minimis rate in accordance with 2 CFR 200 to recover their indirect costs. Governmental Grantees with an existing cost allocation plan may budget accordingly in lieu of an indirect cost rate. Non-governmental Grantees may use a cost allocation plan only if the plan was in place before December 26, 2014.

1.6 Monitoring and Reporting Program Performance

A. **Monitoring.** The Grantee shall monitor performance to assure that time schedules are being met and projected work by time period is being accomplished.

B. **Progress Reports.** The Grantee must submit to the Grant Administrator **Quarterly** progress reports in EGrAMS by the 15th day of the following month of the quarter's end. The progress report must include the following:

1. The percentage of completion of the project objectives. This should include a brief outline of the work accomplished during the reporting period and the work to be completed during the subsequent reporting period.
2. A brief description of problems or delays, real or anticipated, which should be brought to the attention of the Grant Administrator.
3. A statement concerning any significant deviation from the previously agreed-upon Statement of Work.

C. The Grantee must submit a final report and do the following:

1. Submit the final report to the Grant Administrator for review no later than 30 calendar days after the close of the grant agreement period.
2. The final report must include the following information:
 - a. A summary of the project implementation plan and any deviations from the original project as proposed.
 - b. Accomplishments and problems experienced while carrying out the project activities.

- c. Coordinated efforts with other organizations to complete the project.
- d. Impacts, anticipated and unanticipated, experienced as a result of the project implementation.
- e. Financial expenditures of grant money and other contributions to the project, in-kind and/or direct funding.
- f. Any experience in applying the project products and anticipated "next steps".
- g. Actual Budget expenditures compared to the Budget in this Agreement. Include the basis or reason for any discrepancies.

PART II - GENERAL PROVISIONS

2.1 Project Changes

Grantee must obtain prior written approval for project changes from the Department. **See Section 1.2, Detailed Budget.**

2.2 Delegation

Delegation is permitted only with the Department's approval. To delegate this agreement, by whole or part, the Grantee must:

- A. notify the Department at least 90 calendar days before the proposed delegation;
- B. provide a statement ensuring that no conflicts of interest or ethical concerns exist as described in Section 3.9 - Conflict and Ethics; and
- C. provide the Department any information it requests to determine whether the delegation is in its best interest.

2.3 Program Income/Interest Income

A. Program Income

All program income must be used before the submission of the final closeout report for the Fiscal Year (FY) for which program income was earned. All program income must be added into the program budget and used to further program objectives.

Program income means:

- i. Gross income received, and directly generated by a grant-supported activity, or earned only as a result of the grant agreement during the grant period;
- ii. income from fees for services performed from the use of rental of real or personal property acquired with grant funds;
- iii. income from the sale of commodities or items fabricated under a grant agreement; and
- iv. income from payments of principle and interest on loans made with grant funds.

Program income does not include other monetary sources, including but not limited to rebates, credits, discounts, refunds, or interest earned on any of these items.

"During the grant period" means the time between the effective date of the award and the ending date of the award reflected in the final closeout expenditure report.

B. Interest Income

1. Interest income earned by Grantee is not considered program income and must be identified and reported to LEO using Attachment D.
2. Interest income earned is due no later than the 20th calendar day after the end of the calendar quarter.
3. Remittance of interest income earned in excess of \$1,000 for grant

period must be remitted via check made payable to the "State of Michigan," along with a completed remittance submission form (Attachment D) to the following address:

State of Michigan Department of Labor and Economic Opportunity,
Finance PO Box 30823 Lansing, MI 48909

2.4 Share-in-savings

The Department will share in any cost savings realized by the Grantee. Therefore, final Grantee reimbursement will be based on actual expenditures. The Department must approve any exception to this requirement in writing.

2.5 Order of Spending

Unless otherwise required, Grantee shall expend funds in the following order: (1) private or local funds, (2) federal funds, and (3) state funds. Grantee is responsible for securing any required matching funds from sources other than the State.

2.6 Purchase of Equipment

The purchase of equipment not specifically listed in the Budget, Attachment B, must have the Department's prior written approval. Equipment means non-expendable personal property having a useful life of more than one year that costs \$10,000 or more per unit. Grantee will retain the equipment unless otherwise instructed at the time of approval.

2.7 Accounting

The Grantee must adhere to the Generally Accepted Accounting Principles and must maintain records which will allow, at a minimum, for the comparison of actual outlays with budgeted amounts. The Grantee's overall financial management system must ensure effective control over and accountability for all funds received. The Grantee's financial system must provide accurate, current, and complete disclosure of the financial results of the grant funds received. Accounting records must be supported by source documentation including, but not limited to, balance sheets, general ledgers, time sheets and invoices. The expenditure of state funds shall be reported by line item and compared to the Budget. The Grantee must report expenditures on an accrual basis, at a minimum, quarterly.

2.8 Records Maintenance, Inspection, Examination, and Audit

The Department or its designee may audit Grantee to verify compliance with this Grant. Grantee must retain, and provide to the Department or its designee, upon request, all financial and accounting records related to the Grant through the term of the Grant and for 7 years after the latter of termination, expiration, or final payment under this Grant or any extension ("Audit Period"). If an audit, litigation, or other action involving the records is initiated before the end of the Audit Period, Grantee must retain the records until all issues are resolved.

Within 10 calendar days of providing notice, the Department and its authorized representatives or designees have the right to enter and inspect Grantee's premises

or any other places where Grant Activities are being performed, and examine, copy, and audit all records related to this Grant. Grantee must cooperate and provide reasonable assistance. If any financial errors are revealed, the amount in error must be reflected as a credit or debit on subsequent invoices until the amount is paid or refunded. Any remaining balance at the end of the Grant must be paid or refunded within 45 calendar days.

This Section applies to Grantee and Grantee's parent, affiliate, or subsidiary organization and any subgrantee that performs Grant Activities in connection with this Grant.

If the Grantee is a governmental or non-profit organization and expends the minimum level specified in OMB Uniform Guidance, which is one million dollars (\$1,000,000 as of December 26, 2013) or more in total federal funds in its fiscal year, then Grantee is required to submit an Audit Report to the Federal Audit Clearinghouse (FAC) as required in 200.36.

2.9 Insurance requirements

Grantee is responsible for carrying and maintaining insurance coverage as applicable to the projects in this Grant Agreement. All required insurance or self-insurance must:

- a. Protect the state of Michigan from claims that may arise out of, are alleged to arise out of, or result from Grantee's or a subcontractor's performance;
- b. Be primary and non-contributing to any comparable liability insurance (including self-insurance) carried by the state.
- c. Require that subcontractors maintain the required insurances contained in this Section.

This Section is not intended to and is not to be construed in any manner as waiving, restricting or limiting the liability of the Grantee from any obligations under this Agreement.

Each Party must promptly notify the other Party of any knowledge regarding an occurrence which the notifying Party reasonably believes may result in a claim against either Party. The Parties must cooperate with each other regarding such claim.

3.0 Subcontractors

Subcontractor means a person or entity that is awarded a portion of this Grant by Grantee and is obliged to perform that specified portion of the Grant in accordance with the Grant's terms. For any subcontracted activity or product, the Grantee will ensure:

1. That a written subcontract is executed by all affected parties prior to the initiation of any new subcontract activity or delivery of any

subcontracted product. Exceptions to this policy may be granted by the Department if the Grantee asks the Department in writing within 30 days of execution of the Agreement.

2. That any executed subcontract to this Agreement must require the subcontractor to comply with all applicable terms and conditions of this Agreement. If a conflict between this Agreement and the provisions of the subcontract arise, the provisions of this Agreement will prevail.

A conflict between this Agreement and a subcontract, however, will not be deemed to exist where the subcontract:

- a. Contains additional non-conflicting provisions not set forth in this Agreement;
 - b. Restates provisions of this Agreement to afford the Grantee the same or substantially the same rights and privileges as the Department; or
 - c. Requires the subcontractor to perform duties and/or activities in less time than that afforded the Grantee in this Agreement.
3. That the subcontract does not affect the Grantee's accountability to the Department for the subcontracted activity.
 4. That any billing or request for reimbursement subcontract costs is supported by a valid subcontract and adequate source documentation on costs and activities.
 5. That the Grantee will submit a copy of the executed subcontract if requested by the Department.
 6. That the Grantee will conduct monitoring, at least annually, to ensure that the subcontractor is in compliance with the grant agreement.
 7. Grantee is responsible for ensuring its subcontractors, if any, carry and maintain insurance coverage as applicable to the subcontracted service(s).

3.1 Procurement

The Grantee agrees that all procurement transactions involving the use of state funds in excess of \$5,000 must be conducted in a manner that provides maximum open and free competition i.e receiving multiple bids, quotes, and proposals to buy comparable goods and services. When competitive selection is not feasible or practical, the Grantee agrees to obtain the written approval of the Department before making a sole source selection. Sole source contracts should be negotiated to the extent that such negotiation is possible.

3.2 Liability

The Grantee, not the Department, is responsible for all liabilities because of claims, judgments, or costs arising out of activities to be carried out by the Grantee under this

Agreement, if the liability is caused by the Grantee, any contractor or subcontractor, or anyone employed by the Grantee. The Department shall not be liable for any claims, judgments or costs merely by providing grant funding.

3.3 Intellectual Property

Ownership by Grantee

Unless otherwise required by law, all intellectual property developed using funds from this Agreement, including copyright, patent, trademark and trade secret, shall belong to the Grantee.

3.4 Safety

The Grantee, and all subgrantees, are responsible for ensuring that all precautions are exercised at all times for the protection of persons and property. Safety provisions of all Applicable Laws and building and construction codes shall be observed. The Grantee, and every subgrantee, are responsible for complying with all federal, state and local laws and regulations in any manner affecting the work or performance of this Agreement and shall at all times carefully observe and comply with all rules, ordinances, and regulations. The Grantee, and all subgrantees, shall secure all necessary certificates and permits from municipal or other public authorities as may be required in connection with the performance of this Agreement. The Grantee, and all subgrantees, shall safeguard all assets and ensure they are used solely for authorized purposes.

3.5 General Indemnification

Inasmuch as each party to this grant is a governmental entity of the State of Michigan, each party to this grant must seek its own legal representation and bear its own costs; including judgments, in any litigation which may arise from the performance of this grant. It is specifically understood and agreed that neither party will indemnify the other party in such litigation.

3.6 Termination

A. Termination for Cause

The Department may terminate this Grant for cause, in whole or in part, if Grantee, as determined by the Department:

- (a) endangers the value, integrity, or security of any location, data, or personnel;
- (b) becomes insolvent, petitions for bankruptcy court proceedings, or has an involuntary bankruptcy proceeding filed against it by any creditor;
- (c) engages in any conduct that may expose the Department to liability;
- (d) breaches any of its material duties or obligations; or
- (e) fails to cure a breach within the time stated in a notice of breach; or
- (f) fails to meet any terms of the grant agreement.

Any reference to specific breaches being material breaches within this Grant will not be construed to mean that other breaches are not material.

If the Department terminates this Grant under this Section, the Department will issue a termination notice specifying whether Grantee must:

- (a) cease performance immediately, or
- (b) continue to perform for a specified period.

If it is later determined that Grantee was not in breach of the Grant, the termination will be deemed to have been a Termination for Convenience, effective as of the same date, and the rights and obligations of the parties will be limited to those provided in Subsection B, Termination for Convenience.

The Department will only pay for amounts due to Grantee for Grant activities accepted by the Department on or before the date of termination, subject to the Department's right to set off any amounts owed by the Grantee for the Department's reasonable costs in terminating this Grant. The Grantee must pay all reasonable costs incurred by the Department in terminating this Grant for cause, including administrative costs, attorneys' fees, court costs, transition costs, and any costs the Department incurs to procure the Grant activities from other sources.

B. Termination for Convenience

Either party by giving 30 days written notice to the other party stating the reasons for termination and the effective date may terminate this Grant in whole or in part without penalty and for any reason, including but not limited to, appropriation or budget shortfalls. If the Department terminates this Grant for convenience, the Department will pay all allowable costs, as determined by the Department, for Department approved Grant Responsibilities.

C. Stop Work Order

The Department may suspend any or all activities under this Agreement at any time. The Department will provide the Grantee with a written stop work order detailing the suspension. Grantee must comply with the stop work order upon receipt. During a stop work period, the Department will not pay for any activities, Grantee's incurred expenses or financial losses, or any compensation.

3.7 Reallocation or Termination of Funding

If the United States Treasury, State of Michigan legislature, or the State of Michigan government fails to provide or terminates the funding necessary for the Department to fund this Agreement, the Department may terminate this Agreement. Upon such termination of funding, the Department shall have no further obligation to provide Program Funds. Program awards will be revoked and the Program Funds reallocated if the Grantee fails to provide necessary information, fails to meet deadlines, fails to secure the necessary agreements and approvals within the established timeframes, or otherwise fails to cooperate with state partners in a manner sufficient to all state partners for the satisfactory completion of the project. Remaining Program Funds may be reallocated as the Department otherwise sees fit consistent with PA 5 of 2023.

3.8 Clawback Clause

The Department, in its discretion, has the right to recoup or clawback this Grant to collect any funds that are declined, unspent, or otherwise misused, unless otherwise indicated in this Agreement. Grantee must return any funds that become subject to recoupment or clawback.

3.9 Conflicts and Ethics

Grantee, Grantee's parent, affiliate, or subsidiary organization, and any subgrantee that performs Grant Activities in connection with this Grant must uphold high ethical standards and are prohibited from:

- (a) holding or acquiring an interest that would conflict with this Grant;
- (b) doing anything that creates an appearance of impropriety with respect to the award or performance of the Grant;
- (c) attempting to influence or appearing to influence any State employee by the direct or indirect offer of anything of value; or
- (d) paying or agreeing to pay any person, other than employees and consultants working for Grantee, any consideration contingent upon the award of the Grant.

Grantee must immediately notify the Department of any violation or potential violation of these standards.

4.0 Non-Discrimination

Under the Elliott-Larsen Civil Rights Act, 1976 PA 453, MCL 37.2101, et seq., the Persons with Disabilities Civil Rights Act, 1976 PA 220, MCL 37.1101, et seq., and Executive Directive 2019-09, Grantee and its subcontractors agree not to discriminate against an employee or applicant for employment with respect to hire, tenure, terms, conditions, or privileges of employment, or a matter directly or indirectly related to employment, because of race, color, religion, national origin, age, sex, sexual orientation, gender identity or expression, height, weight, marital status, partisan considerations, any mental or physical disability, or genetic information that is unrelated to the person's ability to perform the duties of a particular job or position. Breach of this covenant is a material breach of the Grant Agreement.

4.1 Unfair Labor Practices

Under MCL 423.324, the Department may void this Agreement if the name of the Grantee or the name of a subcontractor, manufacturer, or supplier of the Grantee subsequently appears on the Unfair Labor Practice register compiled under MCL 423.322.

4.2 Prevailing Wage Act Statutory Provision

Grantee must comply with prevailing wage requirements to the extent applicable to this Agreement. As required by MCL 408.1112, if the Michigan Prevailing Wage Act, MCL 408.1101 et seq., applies to this Grant, construction mechanics (as defined in MCL 408.1101 (b)) are intended beneficiaries of the contractual prevailing wage, fringe benefit, and nondiscrimination nonretaliation requirements of the Agreement. Any construction mechanic aggrieved by the failure of a Grantee or subcontractor to pay prevailing wages or benefits as specified in this Agreement, or by a violation of MCL 408.1107, in addition to any other remedies provided in that Act or by law, may bring an action in a court of competent jurisdiction against the Grantee or subcontractor for damages or injunctive relief and may be awarded reinstatement or other appropriate relief, and all damages sustained, together with actual costs and

attorney fees at trial and on appeal. If the Michigan Prevailing Wage Act applies to this Agreement, the rates of wages and fringe benefits to be paid to each class of construction mechanic (as defined in MCL 408.1101 (b)) by the Grantee and subcontractors must not be less than the wage and fringe benefit rates prevailing in the locality in which the work is performed.

4.3 Force Majeure

Neither party will be in breach of this Agreement because of any failure arising from any disaster or acts of god that are beyond their control and without their fault or negligence. Each party will use commercially reasonable efforts to resume performance. Grantee will not be relieved of a breach or delay caused by its subcontractors. If immediate performance is necessary to ensure public health and safety, the Department may immediately contract with a third party.

4.4 Media Releases

News releases (including promotional literature and commercial advertisements) pertaining to the Grant or project to which it relates must not be made without the prior written approval of the Department, and then only in accordance with the explicit written instructions of the Department.

4.5 Website Incorporation

The Department is not bound by any content on Grantee's website unless expressly incorporated into a term of this Agreement.

4.6 Certification Regarding Debarment

By signing this agreement, the Grantee certifies that neither it nor its principals are presently debarred, suspended, proposed for debarment, declared ineligible, or voluntarily excluded from participation in this Agreement by any federal or State department or agency. If the Grantee is unable to certify to any portion of this statement, the Grantee must attach an explanation to this Agreement.

4.7 Illegal Influence

The Grantee certifies, to the best of his or her knowledge and belief that:

- A. No federal appropriated funds have been paid nor will be paid, by or on behalf of the Grantee, to any person for influencing or attempting to influence an officer or employee of any agency, a member of Congress, an officer or employee of Congress, or an employee of a member of Congress in connection with the awarding of any federal contract, the making of any federal grant, the making of any federal loan, the entering into of any cooperative agreement, and the extension, continuation, renewal, amendment, or modification of any federal contract, grant, loan or cooperative agreement.
- B. If any funds other than federal appropriated funds have been paid or will be paid to any person for influencing or attempting to influence an officer or employee of any agency, a member of Congress, an officer or employee of Congress, or an employee of a member of Congress in connection with this grant, the Grantee shall complete and submit Standard Form-LLL, "Disclosure Form to Report Lobbying," in accordance with its instructions.

- C. The Grantee shall require that the language of this certification be included in the award documents for all grants or subcontracts and that all subrecipients shall certify and disclose accordingly.

The Department has relied upon this certification as a material representation. Submission of this certification is a prerequisite for entering into this Agreement imposed by 31 USC § 1352. Any person who fails to file the required certification shall be subject to a civil penalty of not less than \$10,000 and not more than \$100,000 for each such failure.

The Grantee also certifies, to the best of his or her knowledge and belief, that no state funds have been paid nor will be paid, by or on behalf of the Grantee, to any person for influencing or attempting to influence an officer or employee of any State agency, a member of the Legislature, or an employee of a member of the Legislature in connection with the awarding of any state contract, the making of any state grant, the making of any state loan, the entering into of any cooperative agreement, and the extension, continuation, renewal, amendment, or modification of any state contract, grant, loan or cooperative agreement.

4.8 Governing Law

This Grant is governed, construed, and enforced in accordance with Michigan law, excluding choice-of-law principles. Grantee waives any objections, such as lack of personal jurisdiction or an inconvenient forum (i.e., forum non conveniens). Grantee must appoint an agent in Michigan to receive service of process.

4.9 Compliance with Laws

Grantee must comply with all federal, state, and local laws, rules, and regulations.

5.0 Disclosure of Litigation, or Other Proceeding

Grantee must notify the Department within 14 calendar days of receiving notice of any litigation, investigation, arbitration, or other proceeding (collectively, "Proceeding") involving Grantee, a subgrantee, or an officer or director of Grantee or subgrantee, that arises during the term of the Grant, including:

- (a) a criminal Proceeding;
- (b) a parole or probation Proceeding;
- (c) a Proceeding under the Sarbanes-Oxley Act;
- (d) a civil Proceeding involving:
 - (1) a claim that might reasonably be expected to adversely affect Grantee's viability or financial stability; or
 - (2) a governmental or public entity's claim or written allegation of fraud; or
 - (3) a Proceeding involving any license that Grantee is required to possess in order to perform under this Grant.

5.1 Assignment

Grantee may not assign this Grant to any other party without the Department's prior written approval. Upon written notice to Grantee, the Department, in its discretion, may assign in whole or in part, its rights or responsibilities under this Grant to any other party. If the Department determines that a novation of the Grant to a third party is necessary, Grantee will agree to the novation, provide all necessary documentation

and signatures, and continue to perform, with the third party, its Grant obligations.

5.2 Entire Grant and Modification

This Grant is the entire agreement and replaces all previous agreements between the parties for the Grant Activities. This Grant may not be amended except by signed agreement between the parties.

5.3 Grantee Relationship

Grantee assumes all rights, obligations and liabilities set forth in this Grant. Grantee, its employees, and agents will not be considered employees of the State. No partnership or joint venture relationship is created by virtue of this Grant. Grantee, not the Department, is responsible for the payment of wages, benefits, and taxes of Grantee's employees and any subgrantees. Prior performance does not modify Grantee's status as an independent Grantee.

5.4 Dispute Resolution

The parties will endeavor to resolve any Grant dispute in accordance with this provision. The dispute will be referred to the parties' respective Grant Administrators or Program Managers. Such referral must include a description of the issues and all supporting documentation. The parties must submit the dispute to a senior executive if unable to resolve the dispute within 15 business days. The parties will continue performing while a dispute is being resolved, unless the dispute precludes performance. A dispute involving payment does not preclude performance.

Litigation to resolve the dispute will not be instituted until after the dispute has been elevated to the parties' senior executive and either concludes that resolution is unlikely, or fails to respond within 15 business days. The parties are not prohibited from instituting formal proceedings: (a) to avoid the expiration of statute of limitations period; (b) to preserve a superior position with respect to creditors; or (c) where a party makes a determination that a temporary restraining order or other injunctive relief is the only adequate remedy. This Section does not limit the Department's right to terminate the Grant.

5.5 Severability

If any part of this Grant is held invalid or unenforceable, by any court of competent jurisdiction, that part will be deemed deleted from this Grant and the severed part will be replaced by agreed upon language that achieves the same or similar objectives. The remaining Grant will continue in full force and effect.

5.6 Waiver

Failure to enforce any provision of this Grant will not constitute a waiver.

5.7 Incorporation

All attachments, schedules, exhibits or other documents attached or referenced in this agreement are incorporated into this agreement and become terms of the agreement.

5.8 Signatories

The signatories warrant that they are empowered to enter into this Agreement and agree to be bound by it.

Signature: *Gregory Rivet*

Date: 03/31/2026

Gregory Rivet Director
Executive Office
Department of Labor and Economic Opportunity
State of Michigan

Signature:

Date:

Authorized Official
City of Flint

GRANT NO. E20260096

ATTACHMENT A

Objective :	Complete Phases 2–4 of the full roof replacement to stabilize the building envelope and prevent further structural deterioration
Activity :	Execute construction contract amendments (if necessary) Obtain permits and schedule required inspections Remove existing roofing system down to structural decking Install insulation, drainage saddles, recovery board, modified bitumen system Install flashing, coping caps, drain pans, edge metal Secure 30-year manufacturer warranty Conduct final inspections and project close-out
Responsible Staff :	Christian Baldwin - Grants Management Officer, Lee Osborne - Fac. Maint. Op. Mgr
Date Range :	10/01/2025 - 09/30/2030
Expected Outcome :	Full completion of roof replacement (Phases 1–4 completed) Elimination of active leaks and water intrusion Stabilized building envelope with 30-year warranty protection
Measurement :	Certificate of completion Final building inspection approval Manufacturer-issued 30-year warranty Before/after condition documentation
Objective :	Restore elevator functionality and achieve ADA-compliant accessibility throughout the facility.
Activity :	Conduct elevator system assessment Procure contractor for repair/modernization Replace/upgrade mechanical and safety components as needed Complete required inspections and code compliance testing Obtain certification of operational safety and ADA compliance
Responsible Staff :	Christian Baldwin - Grants Management Officer, Lee Osborne - Fac. Maint. Op. Mgr
Date Range :	10/01/2025 - 09/30/2030
Expected Outcome :	Fully operational elevator ADA-compliant vertical access to all public levels Increased accessibility for individuals with disabilities, seniors, and families
Measurement :	Elevator inspection approval certificate ADA compliance verification Documentation of operational testing Removal of accessibility limitation notices (if applicable)

Objective : Prepare the facility for future interior rehabilitation and expanded community programming.

Activity : Stabilize building envelope (roof completion)

Restore vertical accessibility (elevator modernization)

Conduct final building condition assessment post-construction

Document readiness for interior refurbishment phase

Responsible Staff : Christian Baldwin - Grants Management Officer, Lee Osborne - Fac. Maint. Op. Mgr

Date Range : 10/01/2025 - 09/30/2030

Expected Outcome : Structurally sound and accessible facility

Reduced risk of future water damage

Facility ready for interior investment and expanded youth programming

Measurement : Post-project building assessment report

Programming readiness confirmation

Increased facility utilization capacity

ATTACHMENT B

PROGRAM FY26 One Time Enhancement Grant Program			DATE PREPARED 3/31/2026		
CONTRACTOR NAME City of Flint			BUDGET PERIOD From : 10/1/2025 To : 9/30/2030		
MAILING ADDRESS (Number and Street) 1101 S.Saginaw St.			BUDGET AGREEMENT <input checked="" type="checkbox"/> Original <input type="checkbox"/> Amendment		AMENDMENT # 0
CITY Flint	STATE MI	ZIP CODE 48502	FEDERAL ID NUMBER 38-6004611		

	Category	Total	Amount	Cash	Inkind
DIRECT EXPENSES					
Program Expenses					
1	Salaries/Personnel	0.00	0.00	0.00	0.00
2	Fringe Benefits	0.00	0.00	0.00	0.00
3	Employee Travel and Training	0.00	0.00	0.00	0.00
4	Supplies and Materials	0.00	0.00	0.00	0.00
5	Subawards - Subrecipient Services	0.00	0.00	0.00	0.00
6	Contractual - Professional Services	500,000.00	500,000.00	0.00	0.00
7	Communications	0.00	0.00	0.00	0.00
8	Grantee Rent Costs	0.00	0.00	0.00	0.00
9	Space Costs	0.00	0.00	0.00	0.00
10	Capital Expenditures - Equipment & Other	0.00	0.00	0.00	0.00
11	Other	0.00	0.00	0.00	0.00
Total Program Expenses		500,000.00	500,000.00	0.00	0.00
TOTAL DIRECT EXPENSES		500,000.00	500,000.00	0.00	0.00
INDIRECT EXPENSES					
Indirect Costs					
1	Indirect Costs	0.00	0.00	0.00	0.00
2	Cost Allocation Plan	0.00	0.00	0.00	0.00
Total Indirect Costs		0.00	0.00	0.00	0.00

Category	Total	Amount	Cash	Inkind
TOTAL INDIRECT EXPENSES	0.00	0.00	0.00	0.00
TOTAL EXPENDITURES	500,000.00	500,000.00	0.00	0.00

Attachment E - Program Specific Requirements
Attachment E - Program Specific Requirements

Legislatively Directed Spending Items Form
Legislatively Directed Spending Items Form



Mideal Contract No.
200000000034

RESOLUTION NO.: 260223

PRESENTED: 6-17-2026

ADOPTED: _____

BY THE CITY ADMINISTRATOR:

RESOLUTION AUTHORIZING THE PURCHASE OF NEW VEHICLES FROM TRUCK & TRAILER SPECIALTIES BUSINESS FOR FY27

WHEREAS, The City of Flint Finance Department, Fleet Division, is requesting approval to purchase new vehicles from Truck & Trailer Specialties, to support Plowing and salting city streets for departmental operational needs; and replace vehicle #s 4426 and 4430.

WHEREAS The proposed purchase includes \$654,226.00 for (2) snowplow trucks. D&K Truck Company will provide freightliner truck and chassis for a total of \$124,863.00 each. Truck & Trailer will install a Monroe 14' model RDS-168-96-56 (Radius Dump Spreader) Body for a total of \$202,250.00. This is a combined total of \$327,113.00 per snowplow.

Funding is to come from the following account(s):

Account Number	Account Name/ Grant Code	Amount
661-229.000-977.000	Equipment	\$654,226.00
	FY27 TOTAL	\$654,226.00

IT IS RESOLVED that the Proper City Officials are hereby authorized to do all the necessary things to purchase 2 new Salting & Plowing vehicles with Truck & Trailer Specialties for the for FY27 (07/01/26-06/30/27) in total amount not-to-exceed \$654,226.00.

APPROVED AS TO FORM:

JoAnne Gurley
JoAnne Gurley (May 31, 2026 16:58:45 EDT)

Joanne Gurley, City Attorney

APPROVED AS TO FINANCE:

Phillip Moore
Phillip Moore (May 28, 2026 14:13:59 EDT)

Phillip Moore, Chief Financial Officer

FOR THE CITY OF FLINT:

Clyde Edwards
Clyde Edwards / A0660 (Jun 1, 2026 10:07:23 EDT)

Clyde Edwards, City Administrator

APPROVED BY CITY COUNCIL:

APPROVED AS TO PURCHASING:

Lauren Rowley

Lauren Rowley, Purchasing Manager



STAFF REVIEW FORM

Effective: April 1, 2026

(Do not alter or modify this form without written permission from the City Administrator)

TODAY'S DATE: 05/11/2026

BID PROPOSAL #: HQ0004099 / HQ0004117

AGENDA ITEM TITLE: Procurement of (2) Snowplow Trucks

PREPARED BY: Marquita Blair Fleet Administrator

VENDOR NAME: Truck & Trailer Specialties

Section 1. BACKGROUND/SUMMARY OF PROPOSED ACTION..

Vendor Compliance (This vendor has been properly vetted and the responses are below) :

Federal gov't	(All documentation current, no violations)	<input checked="" type="checkbox"/> YES	<input type="checkbox"/> NO
State gov't	(All documentation current, no violations)	<input checked="" type="checkbox"/> YES	<input type="checkbox"/> NO
City of Flint	(All documentation current, no violations)	<input checked="" type="checkbox"/> YES	<input type="checkbox"/> NO

The requesting authority is validating that this vendor has been in full compliance with all past contract provisions and has not violated the terms of any contract with the City of Flint.

NOTE: Preparer **MUST** include a response to the conditions below:

- Did we do an assessment of first consideration to internal City of Flint staff and resources (explain)?
- Why was this vendor chosen?
- What history does this vendor have with the City of Flint?
- What steps will be taken to do a post-performance of the vendor?

Fleet Services is requesting the purchase of two (2) replacement snowplow trucks that are used for plowing and salting city streets during winter months. The Snowplows are needed to replace aging Peterbilt units 4426 and 4430 (both model year 2007).

Truck & Trailer Specialties is a full-service truck body upfitter, installer and mobile hydraulic expert company. They have serviced the public works and commercial trucking since 1974. Truck & Trailer Specialties Inc provided a quote in accordance with MiDeal Contract No. 200000000034 for the upfitting of a freightliner truck and chassis to be converted into a snowplow.

DK Trucks is a full-Service Freightliner, Western Star and Isuzu truck dealer in Michigan, operating in the heavy and medium duty truck industry since 1948. D&K Truck Company provided a quote for (2) freightliner trucks and chassis. The lead time is 18 months with expected delivery between XXX and XXX

This order was previously placed February 20, 2024, purchase requisition number 240008266. The order was more than 18 months out which encumbered 2 different fiscal years, so the project was tabled for the time being.

PROCUREMENT (MUST BE SPECIFIED)

Please specify how this vendor was identified: (Check one)



STAFF REVIEW FORM

Effective: April 1, 2026

(Do not alter or modify this form without written permission from the City Administrator)

- Sole Source (Please attach sole source statement to requisition)
- Competitive Bid Process (Please attach bid tabulation/documents to requisition)
- Cooperative Contract (MiDeal, Sourcewell, GSA, or other municipality)
 - *Contract must be attached to your requisition and contract must appear on the vendor's quote for goods/services
- (3) Quotes (please attach all quotes to your requisition)

Section 2. PREVIOUS ALLOCATIONS (INCLUDE ALL ACCOUNTS USED FOR THIS PURPOSE)/ PROVIDE RESOLUTION OR CONTRACT INFORMATION THAT APPLIES..

Fiscal Year	Account	PO Number	FY PO Amount	FY Expensed	Resolution
FY25	202-447.201-977.000	25-007972	\$11,442.00	\$11,442.00	N/A
FY26	661-229.000-977.000	26-009268	\$17,124.78	\$17,124.78	N/A
FY26	661-229.000-752.000	26-008687	\$10,000.00	\$3,529.58	N/A
FY26	661-229.000-930.000	26-009372	\$10,197.48	\$10,197.48	N/A

25-007972 purchase of solar light arrow boards
 26-009268 upfitting costs for street maintenance
 26-008687 blanket PO for Parts for plow trucks, remaining amount is \$6,470.42
 26-009372 accident damage repair for unit 4436

Section 3. POSSIBLE BENEFIT TO THE CITY OF FLINT (RESIDENTS AND/OR CITY OPERATIONS) INCLUDE PARTNERSHIPS AND COLLABORATIONS..

Snow plowing provides essential safe access for residents. Regular clearing of snow, salting, and sanding helps maintain safe speeds on our streets and prevents vehicles from getting stranded. Neighborhood streets are cleared after major routes are secured, with specialized focus on clearing intersections and dead-ends.

Section 4. FINANCIAL IMPLICATIONS..

IF ARPA related Expenditure:

Has this request been reviewed by E&Y Firm: YES NO IF NO, PLEASE EXPLAIN:



STAFF REVIEW FORM

Effective: April 1, 2026

(Do not alter or modify this form without written permission from the City Administrator)

NOTE: Accountant MUST include the following information:

- What is the total amount budgeted for this purpose?
- What percentage is being spent with this vendor?
- What is the justification for spending this amount of money with this vendor?
- What percentage is being spent out of each line item used in this request?
- List all the known budgeted funds from that line item.

N/A not ARPA related

Total amount budgeted for this purpose: \$654,226.00 for (2) snowplow trucks

D&K Truck Company will provide the freightliner truck and chassis for a total of \$124,863.00 each.

Truck & Trailer will install a Monroe 14' model RDS-168-96-56 (Radius Dump Spreader) Body for a total of \$202,250.00. This is a combined total of \$327,113.00 per snowplow.

Percentage being spent with this vendor: \$124,860 is 38.17% of \$327,113. And \$327,113 is 61.83% of \$529,000

Justification for spending this amount of money with this vendor: There are 2 vendors included in order to make this purchase. You must purchase a truck and chassis then you need a body upfitter to turn the truck into a snowplow. To continue snowplowing service in the city of flint, the aging equipment will need to be replaced as it reaches its life expectancy. Retiring old equipment reduces down-time and excessive repair costs.

BUDGETED EXPENDITURE? YES NO IF NO, PLEASE EXPLAIN:

Dept.	Name of Account	Account Number	Grant CODE	Amount
3331	Equipment	661-229.000-977.000	N/A	\$124,860
3331	Equipment	661-229.000-977.000	N/A	\$124,860
3331	Equipment	661-229.000-977.000	N/A	\$202,250
3331	Equipment	661-229.000-977.000	N/A	\$202,250
FY27 GRAND TOTAL				\$654,226.00

WHEN APPLICABLE, IF MORE THAN ONE (1) YEAR, PLEASE ESTIMATE TOTAL AMOUNT FOR EACH BUDGET YEAR: (This will depend on the term of the bid proposal)

BUDGET YEAR 1: _____

BUDGET YEAR 2: _____

BUDGET YEAR 3: _____

OTHER IMPLICATIONS (i.e., collective bargaining).. _____

PRE-ENCUMBERED? YES NO REQUISITION NO: 27-0011500 _____



STAFF REVIEW FORM

Effective: April 1, 2026

(Do not alter or modify this form without written permission from the City Administrator)

ACCOUNTING APPROVAL: *J. Janski* J. Janski (May 15, 2026 13:17:38 EDT) Date: _____

WILL YOUR DEPARTMENT NEED A CONTRACT? YES NO

Section 5. RESOLUTION DEFENSE TEAM..

(Place the names of those who can defend this resolution at City Council)

	NAME	PHONE NUMBER
1	Dan Schiller	810.691.4788
2	Marquita Blair	810.423.5650
3	Kathryn Neumann	
4		

STAFF RECOMMENDATION: (PLEASE SELECT): APPROVED NOT APPROVED

DEPARTMENT HEAD SIGNATURE: *Marquita Blair, Fleet Administrator*
(Name, Title)

ADMINISTRATION APPROVAL: *CDE*
Clyde Edwards (May 15, 2026 15:05:12 EDT)
(\$20,000 or above spending authorizations)

Section 6. VENDOR EVALUATION..

Business Title: Truck & Trailer
Specialties _____ Vendor ID: 003086

Review Period: _____ Department: Fleet

Project Name: Procurement
of 2 Snowplow Trucks _____ Project Type:
Purchase

Vendor Goals:

To order, supply and configure (2) freightliner 114SD models and outfit them with heavy-duty plows, salt spreaders and hydraulic systems as quoted according to the MiDeal terms.



STAFF REVIEW FORM

Effective: April 1, 2026

(Do not alter or modify this form without written permission from the City Administrator)

	1 = Poor	2 = Fair	3 = Sufficient	4 = Good	5 = Excellent
Job Knowledge:	<input type="checkbox"/>	<input type="checkbox"/>	<input type="checkbox"/>	<input type="checkbox"/>	<input checked="" type="checkbox"/>
Work Quality:	<input type="checkbox"/>	<input type="checkbox"/>	<input type="checkbox"/>	<input checked="" type="checkbox"/>	<input type="checkbox"/>
Timeliness:	<input type="checkbox"/>	<input type="checkbox"/>	<input checked="" type="checkbox"/>	<input type="checkbox"/>	<input type="checkbox"/>
Compliance with Contract:	<input type="checkbox"/>	<input type="checkbox"/>	<input checked="" type="checkbox"/>	<input type="checkbox"/>	<input type="checkbox"/>
Warranty (If Product):	<input type="checkbox"/>	<input type="checkbox"/>	<input checked="" type="checkbox"/>	<input type="checkbox"/>	<input type="checkbox"/>
Responsiveness:	<input type="checkbox"/>	<input type="checkbox"/>	<input type="checkbox"/>	<input type="checkbox"/>	<input checked="" type="checkbox"/>
Cost Effectiveness:	<input type="checkbox"/>	<input type="checkbox"/>	<input type="checkbox"/>	<input checked="" type="checkbox"/>	<input type="checkbox"/>
Dependability:	<input type="checkbox"/>	<input type="checkbox"/>	<input type="checkbox"/>	<input type="checkbox"/>	<input checked="" type="checkbox"/>
Total Performance:	<input type="checkbox"/>	<input type="checkbox"/>	<input type="checkbox"/>	<input checked="" type="checkbox"/>	<input type="checkbox"/>
Overall Rating:	<input type="checkbox"/>	<input type="checkbox"/>	<input type="checkbox"/>	<input checked="" type="checkbox"/>	<input type="checkbox"/>

DEFECTS (IF ANY): IF CHECKED, PLEASE EXPLAIN:

N/A no defects to report

Performance / Other Comments:

Truck and Trailer is a trusted vendor. They are specialists when it comes to upfitting truck bodies. They provide custom design, fabrication, and installation of vocational bodies and equipment for commercial fleets. These experts optimize vehicles for specific industries like construction, and utilities through secure storage, lighting, and specialized hydraulic systems. They are partners with D&K Truck Company an OEM Freightliner dealer in order to receive trucks directly from the factory for modification before final delivery, which saves transit time.

REVIEWER'S SIGNATURE:

Dan Schiller

Dan Schiller (May 15, 2026 14:57:08 EDT)

Date:

TRUCK & TRAILER Specialties, Inc.

900 Grand Oaks Drive | Howell, MI 48843 | www.ttspec.com | ph: (517) 290-9876 | fx: (517) 552-3666

May 4, 2026

City of Flint
702 West 12th Street, Flint, MI 48502
Attn: Marquita Blair, ph: (810) 423-5650
HQ0005404

MIDEAL

State Contract No: 200000000034

Equipment Quotation utilizing the state contract awarded to Truck & Trailer Specialties, Inc.

Install Monroe 14' model RDS-168-96-56 (Radius Dump Spreader) Body including the following:

Body capacity 10 yards water level and 12 yards with sideboards
Overall length is 168", outside width is 96" and overall side height is 56"
Tailgate height is 50", side height is 44" and 50" at the front
Body shell is constructed of unpainted 3/16" 201 stainless steel
Body longitudinals are ¼" 201 stainless steel
Air-operated tailgate release
Conveyor trough is 34" wide
667XH chain with crossbars on every-other link/4.5" centers
Rear tailgate includes a removable rear metering gate and a blank insert
Extended tandem axle fender kit installed integrally to the body of 7-gauge 201 stainless steel
Twin Rawson-type 6:1 gear boxes with 17.8 CI motors
8-tooth hardened sprockets with 2" drive and idler shafts for the conveyor
Grease extension kit for rear bearings, tailgate pivot arms, front bearings and hoist trunnion
1/2 cabshield constructed of 7-gauge 201 stainless steel
Mudflaps installed in front of and behind drive tires
Backup alarm included
Four (4) oval light holes cut into each rear pillar
Install chassis frame-mounted, removable stainless steel spillshields to collect carry-over of salt
Install 6" hardwood sideboards on body
Install branch deflector on cabshield to protect tarp system, curbside
Install one (1) shovel holder on RDS bulkhead, curbside
Install one (1) fold-down stainless steel ladder mounted on the streetside rear of the body
Install bracket for the license plate on the rear tailgate on the left side
Install RDS-168 trough/floor cover kit, ¼" steel construction, powder-coated Black

Install Monroe Closed-Loop Pre-Wet System including the following:

NEMA weather-tight fiberglass pump enclosure
Hydraulic driven 7 GPM pump assembly with Dickey-john flow meter
5 PSI in-line check valve for nozzles
Three (3) nozzles with brass tips and caps
Twin (2) 100-gallon tanks with stainless steel attaching hardware
Includes dual crossover tubes, bulk fill adapter and flusher kit
Remote vent tube for each tank

Install Rear Spinner Assembly including the following:

Dual, receiver-type tubular mounting, stainless steel receiver with 6" long tube for added support
Formed 24" poly spinner disc
Spinner motor includes seal saver
Direction chute on inside of spinner with 3 exterior adjustable deflectors

TRUCK & TRAILER *Specialties, Inc.*

900 Grand Oaks Drive | Howell, MI 48843 | www.ttspec.com | ph: (517) 290-9876 | fx: (517) 552-3666

Construction is type 201 stainless steel

Install grab handles to the Rear Spinner Assembly to aide removal

Install Mailhot-type Telescopic Hoist including the following:

Hoist is double-acting and includes nitrated cylinders

Hoist includes oscillating mounting collar and is trunnion-mounted

Hoist is NTEA class 90

Install Roll-Rite Electric Tarp System including the following:

TarpMaster motor/gear box

Mesh tarp cover

Aluminum tarp and 4-spring tension bows with offset elbows

Aluminum wind deflector

Install Rexroth A10VO100 Hydraulic Load-Sense Piston Pump including the following:

Pump is front-mounted with 100CC displacement

Front crossmember for pump mounting

Spicer 1310 driveline

12-volt auto shutdown block

Low-oil shutdown valve and override circuit

Install Rexroth 9m4-12 Load-Sense Hydraulic Valve including the following:

Pressure-compensated flow controls for the following functions:

Air section for Dump Hoist with 500 PSI A-port load-sense limit DA

Air section for Scraper up/down with 500 PSI A-port load-sense limit DA

Air section for Scraper swing DA

Air section for Front Plow up/down DA

Air section for Front Plow swing DA

Air section for Wing Plow swing DA

EPC section for Conveyor

EPC section for Spinner

EPC section for Pre-wet

Stainless steel pipe for hydraulic lines to rear

Stainless steel hydraulic quick couplers for front plow & spinner with dust plugs & caps

Install TTS Pneu-Logic multi-function single air-operated joystick including the following:

Scraper, Front Plow, Wing Plow & Hoist operations as well as remote pause/blast buttons on joystick

Heads-up display for indicating joystick functions

All necessary hoses and fittings

Install Rexroth CS630 Electric Spreader Controller including the following:

Designed to operate in open-loop, groundspeed orientation, groundspeed-triggered or manual modes including pause & blast features

Controller mounted between the seats on a console

All necessary hoses and fittings

Install Monroe Combination Fuel/Hydraulic Oil/Valve Enclosure including the following:

100-gallon fuel capacity, 35-gallon oil capacity (mos. 00166450 & 248896)

7-gauge type 201 stainless steel construction

Valve enclosure integral to the tank

Valve enclosure with a lockable "T" handle latch, contained within driver's side of combo tank

Mounting brackets are 4" ship and car channel

Ispro solid state fuel gauge sending unit

Ball-valve shutoff on supply line and case and fuel ports

Tank-mounted return line oil filter

35-gallon AW32 hydraulic oil

Low oil sending unit

Sight/temp indicator gauge

TRUCK & TRAILER *Specialties, Inc.*

900 Grand Oaks Drive | Howell, MI 48843 | www.ttspec.com | ph: (517) 290-9876 | fx: (517) 552-3666

Suction strainer

Tank labels included

Install curbside safety fuel hook mounted on tank

Install 3-step egress & platform from streetside fender to combo tank, painted Red to match cab

Install Monroe 29" Husting truck-portion Hitch including the following:

12" channel front bumper with tapered ends

3" DA lift cylinder with Socatri rod

Front tow hooks to be mounted on hitch's kicker legs

Plow cushion valve mounted under bumper driver's side

All necessary supports and bracing

Install Monroe 12' model MS4512 Underbody Scraper including the following:

12' x 20" x 1" moldboard

½" thick hanger board with grease manifold brackets installed

Two, 4" power-reverse cylinder with 2" Socatri rods

Two, 3.5" actuating cylinders with 2" Socatri rods

All cylinders have poly pack seals

1" circle with 5" greaseable center bolt

Circle includes a welded in hardened bushing

2" clevis bosses on power-reverse cylinders

Contoured circle clamps with poly type wear pads

Three reinforced moldboard hinges with gussets

3/8" pipe and hoses for faster scraper actuation

Hinge shaft is 2.5" cold-rolled round stock

Moldboard hinges are constructed of 3/8" wall DOM tubing

Adjustable j-50 relief valve is included

Cushion valve for power-reverse circuit is included

Remote lube manifolds and grease lines

Piloted center pin

Bolt-in trunnion caps for canisters

Install standard 6" cutting edges

Install serrated safety step on end of moldboard, streetside

Install Ray Stop moldboard protection kit

Paint Red bands at each end of moldboard to match cab

Install Monroe 7' Para-Glide Jr. Wing for tandem axle chassis including the following (HQ0004114):

Moldboard inboard shall be 27" and outboard height to be 28" (mo. 00214680)

Both inboard and outboard measurements include the 8" cutting edge installed

Moldboard shall be 3/16" A36 steel

Moldboard includes a 4" x 4" x ¾" bottom angle

Top of moldboard shall be formed into a 2-3/4" x 1" channel for additional strength

Para-Glide style wing post mounted behind the scraper

Wing post shall be of a trailing link style with 12" of lift and designed to allow the moldboard to float up a minimum of 8-12" when in the plowing position

Junior wing includes a heel cylinder that lifts off the banjo plate

Long rear push-arm to be used with tandem axle chassis

Rear push-arm is to be equipped with a 6" cushion spring

Rear push-arm have bolt-in design with grease zerks for ease of maintenance

Front arm banjo plate has captive design

Moldboard is powder-coated Orange

D-type rubber bumper stops

Safety chain at rear

5" x 7" rear cross tube for rear wing support

TRUCK & TRAILER Specialties, Inc.

900 Grand Oaks Drive | Howell, MI 48843 | www.ttspec.com | ph: (517) 290-9876 | fx: (517) 552-3666

- Sequencing valve with hoses and couplers
- Install grease line manifold (mo. 001847301) for Para-Glide post
- Install stainless steel bracket on end of wing moldboard with a flush-mounted SoundOff dual mPower (mo. EMPSA0B0B-P) amber/green flasher light pointed rearward and an LED marker light pointed forward
- One (1) 36" Tribal Whip (mo. 36WG) green LED liquid-filled light stick on Wing, laid down on top backside
- Install recycled rubber tire cutting edge for 7' Jr. Wing
- Weld on a 2" solid piece of steel on the edge of the cutting edge to act as a curbguard for the wing
- Install two (2) Monroe low-profile wing shoes (mo. 05050220), one each at toe & heel of cutting edge
- Install safety clamp for wing push-arm spring
- Stainless steel couplers for wing circuits
- Install LaserLine model GL3000PMC Wing Plow Guidance Laser including the following:**
 - Green "ultra-bright" laser assembly enclosed in weatherproof housing
 - Heated front window lens to reduce or eliminate icing
 - Pneumatic air blast mechanism for lens, blasting every 5 seconds
 - Control switch installed in-cab for laser on/off and air blast on/off
 - Laser assembly installed on roof of cab
- Install Custom Lighting & Electrical System including the following:**
 - Two (2) Grote heated LED plow lights & aluminum brackets (mo. GR-84661-4) mounted TBD from ground
 - Two (2) SoundOff LED (mo. ELB45BCHOPC) amber/green 6" beacons on cab roof chassis brackets
 - Two (2) SoundOff mPower (mo. EMPS20V38-P) amber/green LED flashers mounted:
 - Two (2) in chassis grille (on separate switch)
 - Four-hole, in-pillar 6" oval lights including the following from top down:
 - Two (2) SoundOff LED solid Green flashers in top holes
 - Two (2) SoundOff LED STT lights, 2nd from top
 - Two (2) SoundOff LED backup lights, 3rd from top
 - Two (2) SoundOff LED solid Amber flashers in bottom holes
 - One (1) Maxxima LED work light at driver-side corner of body to illuminate salt spread pattern
 - Two (2) Maxxima LED work lights one each side to illuminate Scraper
 - One (1) Maxxima LED work light to illuminate Wing Plow
 - LED clearance marker light kit on Dump Body
 - No 3-light cluster
 - Programmable chassis switches six (6) for the following:**
 - Flashers and work lights for Scraper, Wing Plow & Spreader
 - Pneu-Logic Joystick console switches for the following (ordered L-R):**
 1. Air Tailgate w/ Safety cap
 2. Tarp In/ Tarp Out
 3. Low-oil Override/ Pump Shutdown
 - Heads-up Display indicators in-cab for the following:**
 - Scraper, Front Plow, Wing Plow, Tailgate Open, Low-oil, Body-up & Pump Shutdown
 - Proximity switch for Dump body-up light with loud audible alarm
 - Proximity switch for Scraper (for future Samsara)
 - Proximity switch for Wing Plow (for future Samsara)
 - Backup alarm
 - Betts junction box with sealed wiring mounted at RDS body streetside
 - All wiring to be soldered, heat-shrunk and in protective loom
- Install Road Watch Temperature System kit includes the following:**
 - Temperature sensor bracket-mounted on mirror including extension cable
 - Display monitor mounted in dash
- Install Voyager Rearview Camera with Wash System including the following:**
 - System tying into chassis wiper fluid reservoir
 - Chassis wiper controls for activating wash system, momentary in-cab switch for air puffer

TRUCK & TRAILER *Specialties, Inc.*

900 Grand Oaks Drive | Howell, MI 48843 | www.ttspec.com | ph: (517) 290-9876 | fx: (517) 552-3666

- Air puffer & washer fluid tubing
- VCAHD25B color camera, waterproof, IR low-light assist (19 LEDs), mounted in rear sill
- MSF5000 stainless steel camera box
- VOM719WP 7" LCD color monitor, waterproof
- CEC34L1 loomed 34' main cable for monitor
- VOSHD6MNT double-knuckle monitor mount
- Install Groeneveld Model #EP-O autolube grease system for Chassis, Hoist, Scraper & Wing**
- Install ¾" Rear Hitch Assembly including the following:**
 - PH30 30-ton rated pintle hook, multi-drill pattern for adjustable mounting heights (mounted at TBD)
 - Rear tow hooks mounted outside of frame rails
 - Heavy-duty D-rings for safety chains
 - 7-way round pin plug
 - Remount glad hands as far outside of frame rails as possible
- Install Electric Brake Controller**
- Install Minimizer Floor Mats for Freightliner 108SD Plus (mo. 10045112)**
- Paint Bottom of body, body hinge, body props, front & rear hitch and attaching hardware Black**

Above installed, non-stainless equipment painted pricing: \$202,250.00 ea.

Minimum full 1-year warranty on parts and labor on all equipment.

Payment Terms: Net 30. Pricing effective for 30 days.

FOB: City of Flint

Delivery: 18 months ARO

Chassis requirements to be confirmed at time of order:

- Freightliner 108 SD
- 136" CT & 202" WB
- Highest ground clearance package
- Batteries outside LH frame, as far back as possible
- Raised curbside underdoor horizontal aftertreatment with curbside vertical tailpipe
- Front PTO provision
- 52" rear axle spacing
- 7-way trailer wiring to rear for electric brake controller
- Air lines to rear
- Front integral frame extension
- Delete OEM front bumper
- Front tow hooks
- Temporary fuel tank
- Stationary grille
- Plow light/Headlight switch and related OEM wiring
- Programmable 6-pack of switches
- Stainless steel cab brackets for beacons and wiring

Thank you for the opportunity to quote.

Respectfully submitted by,
Jon Luea/Brian Bouwman

Prepared for:
Marquita Blair
Flint City Of
702 W 12th St

Flint, MI 48503
Phone: 810-423-5650

Prepared by:
Mike Denno
D and K TRUCK COMPANY
3020 Snow Rd
LANSING, MI 48917
Phone: 517-449-2329

*A proposal for
Flint City Of*

*Prepared by
D and K TRUCK COMPANY
Mike Denno*

Feb 27, 2026

Freightliner 114SD Plus

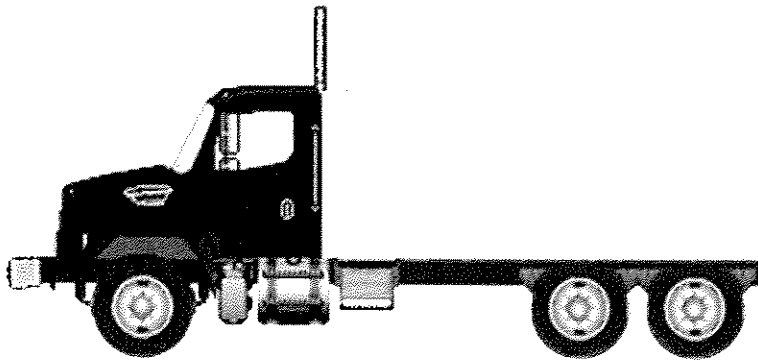

Components shown may not reflect all spec'd options and are not to scale



Prepared for:
 Marquita Blair
 Flint City Of
 702 W 12th St
 Flint, MI 48503
 Phone: 810-423-5650

Prepared by:
 Mike Denno
 D and K TRUCK COMPANY
 3020 Snow Rd
 LANSING, MI 48917
 Phone: 517-449-2329

Q U O T A T I O N

114SD PLUS CONVENTIONAL CHASSIS

SET BACK AXLE - TRUCK CUM L9 330 HP @ 2200 RPM; 2200 GOV RPM, 1000 LB-FT @ 1200 RPM ALLISON 3000 RDS AUTOMATIC TRANSMISSION WITH PTO PROVISION MERITOR MT-40-14X 40,000# R-SERIES TANDEM REAR AXLE HENDRICKSON HAULMAAX EX 40,000# REAR SUSPENSION DETROIT DA-F-16.0-5 16,000# FL1 71.0 KPI/3.74 DROP SINGLE FRONT AXLE 16,000# TAPERLEAF FRONT SUSPENSION	114 INCH BBC FLAT ROOF ALUMINUM CONVENTIONAL CAB 5125MM (202 INCH) WHEELBASE NO FIFTH WHEEL 1/2X3.64X11-7/8 INCH STEEL FRAME (12.7MMX301.6MM/0.5X11.88 INCH) 120KSI 1900MM (75 INCH) REAR FRAME OVERHANG PARTIAL INNER FRAME REINFORCEMENT AT FRONT SUSPENSION TEM TO EVALUATE AND INSTALL FRAME RAIL REINFORCEMENT AS NEEDED FOR FRONT FRAME MOUNTED EQUIPMENT
--	---

		PER UNIT		TOTAL
VEHICLE PRICE	TOTAL # OF UNITS (1)	\$ 123,848	\$	123,848
EXTENDED WARRANTY		\$ 0	\$	0
DEALER INSTALLED OPTIONS		\$ 740	\$	740
CUSTOMER PRICE BEFORE TAX		\$ 124,588	\$	124,588

TAXES AND FEES

TAXES AND FEES	\$	275	\$	275
OTHER CHARGES	\$	0	\$	0

TRADE-IN

TRADE-IN ALLOWANCE	\$	(0)	\$	(0)
BALANCE DUE	(LOCAL CURRENCY)	\$ 124,863	\$	124,863

APPROVAL:
 Please indicate your acceptance of this quotation by signing below:

Customer: X _____ Date: ___ / ___ / ___.



Prepared for:
Marquita Blair
Flint City Of
702 W 12th St

Flint, MI 48503
Phone: 810-423-5650

Prepared by:
Mike Denno
D and K TRUCK COMPANY
3020 Snow Rd
LANSING, MI 48917
Phone: 517-449-2329

QUOTATION DETAILS

TAXES AND FEES

Title	\$	15	\$	15
Doc Fee	\$	260	\$	260

Daimler Truck Financial

Financing that works for you.

See your local dealer for a competitive quote from Daimler Truck Financial, or contact us at Information@dtfoffers.com.

Daimler Truck Financial offers a variety of finance, lease and insurance solutions to fit your business needs. For more information about our products and services, visit our website at www.daimler-truckfinancial.com.



Prepared for:
 Marquita Blair
 Flint City Of
 702 W 12th St
 Flint, MI 48503
 Phone: 810-423-5650

Prepared by:
 Mike Denno
 D and K TRUCK COMPANY
 3020 Snow Rd
 LANSING, MI 48917
 Phone: 517-449-2329

S P E C I F I C A T I O N P R O P O S A L

Data Code	Description	Weight Front	Weight Rear	Retail Price
Price Level				
PRL-30D	SD PRL-30D (EFF:MY27 ORDERS)			STD
Data Version				
DRL-026	SPECPRO21 DATA RELEASE VER 026			N/C
Vehicle Configuration				
001-177	114SD PLUS CONVENTIONAL CHASSIS	7,934	6,476	\$170,892.00
004-227	2027 MODEL YEAR SPECIFIED			STD
002-004	SET BACK AXLE - TRUCK	480	-480	(\$1,270.00)
019-006	TRAILER TOWING PROVISION AT END OF FRAME WITH SAE J560	10	10	\$1,025.00
003-001	LH PRIMARY STEERING LOCATION			STD
General Service				
AA1-003	TRUCK/TRAILER CONFIGURATION			N/C
AA6-002	DOMICILED, USA (EXCLUDING CALIFORNIA AND CARB OPT-IN STATES)			STD
99D-027	EPA CLEAN IDLE LABEL - (INCLUDES 6X4 INCH LABEL ON LOWER FORWARD OF DRIVER DOOR)			STD
A85-011	CONSTRUCTION SERVICE			STD
A84-1GM	GOVERNMENT BUSINESS SEGMENT			N/C
AA4-010	DIRT/SAND/ROCK COMMODITY			N/C
AA5-002	TERRAIN/DUTY: 100% (ALL) OF THE TIME, IN TRANSIT, IS SPENT ON PAVED ROADS			STD
AB1-008	MAXIMUM 8% EXPECTED GRADE			STD
AB5-001	SMOOTH CONCRETE OR ASPHALT PAVEMENT - MOST SEVERE IN-TRANSIT (BETWEEN SITES) ROAD SURFACE			STD
995-1AD	FREIGHTLINER LEVEL I WARRANTY			STD
A66-99D	EXPECTED FRONT AXLE(S) LOAD : 16000.0 lbs			
A68-99D	EXPECTED REAR DRIVE AXLE(S) LOAD : 40000.0 lbs			
A63-99D	EXPECTED GROSS VEHICLE WEIGHT CAPACITY : 56000.0 lbs			
A70-99D	EXPECTED GROSS COMBINATION WEIGHT : 80000.0 lbs			



Prepared for:
 Marquita Blair
 Flint City Of
 702 W 12th St
 Flint, MI 48503
 Phone: 810-423-5650

Prepared by:
 Mike Denno
 D and K TRUCK COMPANY
 3020 Snow Rd
 LANSING, MI 48917
 Phone: 517-449-2329

Data Code	Description	Weight Front	Weight Rear	Retail Price
Truck Service				
AA3-073	BELLY PLOW BODY WITH HIGH GROUND CLEARANCE			N/C
A89-99D	BRAKING-EXPECTED CAB TO BODY CLEARANCE : 26.0 in			
AF3-2A8	TRUCK AND TRAILER SPECIALTIES INC.			N/C
Tractor Service				
AA2-005	FLATBED TRAILER			N/C
AH6-001	SINGLE (1) TRAILER			N/C
Engine				
101-3BP	CUM L9 330 HP @ 2200 RPM; 2200 GOV RPM, 1000 LB-FT @ 1200 RPM	-850	-70	(\$12,240.00)
Electronic Parameters				
	79A-062	62 MPH ROAD SPEED LIMIT		N/C
N	79B-005	CRUISE CONTROL SPEED LIMIT 2 MPH LOWER THAN ROAD SPEED LIMIT		N/C
	79G-106	10 MINUTE IDLE SHUTDOWN - TIMER RESET WITH CLUTCH AND SERVICE BRAKE		N/C
	79K-005	PTO MODE ENGINE RPM LIMIT - 900 RPM		N/C
	79M-001	PTO ENGINE SPEED CONTROL DEACTIVATED BY SERVICE BRAKE LIGHTLY APPLIED (STATIONARY APPLICATIONS)		N/C
	79P-004	PTO RPM WITH CRUISE SET SWITCH - 900 RPM		N/C
	79U-001	PTO GOVERNOR RAMP RATE - 25 RPM PER SECOND		N/C
	79W-024	CRUISE CONTROL BUTTON PTO CONTROL		N/C
	80P-998	NO FLEET SPEC FOR PARAMETERIZATION		N/C
	80G-022	PTO MINIMUM RPM - 775		N/C
	80J-002	REGEN INHIBIT SPEED THRESHOLD - 5 MPH		N/C
	80S-003	PTO 1, DASH SWITCH, ENGAGE BEFORE DRIVING		N/C
	80V-001	ENGINE MOUNT PTO, DASH SWITCH ENGAGES PTO MODE, STATIONARY OPERATION		N/C
Engine Equipment				
	99C-024	EPA 2010/GHG 2024 CONFIGURATION		STD
	13E-001	STANDARD OIL PAN		STD
	105-001	ENGINE MOUNTED OIL CHECK AND FILL		STD
	014-109	SIDE OF HOOD AIR INTAKE WITH FIREWALL MOUNTED DONALDSON AIR CLEANER WITH SAFETY ELEMENT, PASSIVE PRECLEANER AND INSIDE/OUTSIDE AIR WITH SNOW DOOR	10	\$1,120.00



Prepared for:
 Marquita Blair
 Flint City Of
 702 W 12th St
 Flint, MI 48503
 Phone: 810-423-5650

Prepared by:
 Mike Denno
 D and K TRUCK COMPANY
 3020 Snow Rd
 LANSING, MI 48917
 Phone: 517-449-2329

Data Code	Description	Weight Front	Weight Rear	Retail Price
124-1D7	DR 12V 160 AMP 28-SI QUADRAMOUNT PAD ALTERNATOR WITH REMOTE BATTERY VOLT SENSE			STD
292-236	(3) DTNA GENUINE, FLOODED STARTING, MIN 3000CCA, 555RC, THREADED STUD BATTERIES			STD
290-1CD	BATTERY BOX WITH ALUMINUM COVER MOUNTED SHORT SIDE TO RAIL	15		\$248.00
281-001	STANDARD BATTERY JUMPERS			STD
282-042	LH BATTERY BOX MOUNTED AS FAR AFT AS POSSIBLE, NO GREATER THAN 60 INCHES BACK OF CAB			\$257.00
291-017	WIRE GROUND RETURN FOR BATTERY CABLES WITH ADDITIONAL FRAME GROUND RETURN			STD
289-001	NON-POLISHED BATTERY BOX COVER			STD
293-060	NON-ESSENTIAL POSITIVE LOAD DISCONNECT, LOCKING IN CAB CONTROL SWITCH MOUNTED OUTBOARD OF DRIVER SEAT	2		\$270.00
306-015	PROGRESSIVE LOW VOLTAGE DISCONNECT AT 12.3 VOLTS FOR DESIGNATED CIRCUITS	2		STD
107-032	CUMMINS TURBOCHARGED 18.7 CFM AIR COMPRESSOR WITH INTERNAL SAFETY VALVE			N/C
152-041	ELECTRONIC ENGINE INTEGRAL SHUTDOWN PROTECTION SYSTEM			STD
128-076	CUMMINS ENGINE INTEGRAL BRAKE WITH VARIABLE GEOMETRY TURBO ON/OFF	20		N/C
016-1E2	RAISED RH OUTBOARD UNDER STEP MOUNTED HORIZONTAL AFTERTREATMENT SYSTEM ASSEMBLY WITH RH B-PILLAR MOUNTED VERTICAL TAILPIPE	40	35	\$1,675.00
28F-014	ENGINE AFTERTREATMENT DEVICE, AUTOMATIC OVER THE ROAD REGENERATION AND VIRTUAL REGENERATION REQUEST SWITCH IN CLUSTER			STD
239-020	10 FOOT 00 INCH (120 INCH+0/-5.9 INCH) EXHAUST SYSTEM HEIGHT			(\$25.00)
237-1F8	RH CURVED VERTICAL TAILPIPE B-PILLAR RAISED UNDER STEP MOUNTED AFTERTREATMENT SYSTEM			N/C
N 23U-002	13 GALLON DIESEL EXHAUST FLUID TANK			STD
30N-003	100 PERCENT DIESEL EXHAUST FLUID FILL			STD
23Y-001	STANDARD DIESEL EXHAUST FLUID PUMP MOUNTING			STD
23Z-002	NON-POLISHED ALUMINUM DIAMOND PLATE DIESEL EXHAUST FLUID TANK COVER	15	5	\$145.00
43X-002	LH MEDIUM DUTY STANDARD DIESEL EXHAUST FLUID TANK LOCATION			STD



Prepared for:
 Marquita Blair
 Flint City Of
 702 W 12th St
 Flint, MI 48503
 Phone: 810-423-5650

Prepared by:
 Mike Denno
 D and K TRUCK COMPANY
 3020 Snow Rd
 LANSING, MI 48917
 Phone: 517-449-2329

Data Code	Description	Weight Front	Weight Rear	Retail Price
43Y-001	STANDARD DIESEL EXHAUST FLUID TANK CAP			STD
242-011	ALUMINUM AFTERTREATMENT DEVICE/MUFFLER/TAILPIPE SHIELD(S)			N/C
273-058	AIR POWERED ON/OFF ENGINE FAN CLUTCH			STD
276-001	AUTOMATIC FAN CONTROL WITHOUT DASH SWITCH, NON ENGINE MOUNTED			STD
110-003	CUMMINS SPIN ON FUEL FILTER			N/C
118-008	COMBINATION FULL FLOW/BYPASS OIL FILTER			N/C
120-998	NO COOLANT FILTER	-10		STD
266-017	1300 SQUARE INCH ALUMINUM RADIATOR	-50		N/C
103-039	ANTIFREEZE TO -34F, OAT (NITRITE AND SILICATE FREE) EXTENDED LIFE COOLANT			STD
171-007	GATES BLUE STRIPE COOLANT HOSES OR EQUIVALENT			STD
172-001	CONSTANT TENSION HOSE CLAMPS FOR COOLANT HOSES			STD
270-016	RADIATOR DRAIN VALVE			N/C
168-002	LOWER RADIATOR GUARD	6		\$116.00
360-013	1350 ADAPTER FLANGE FOR FRONT PTO PROVISION	20		\$1,490.00
138-011	PHILLIPS-TEMRO 1000 WATT/115 VOLT BLOCK HEATER	4		\$92.00
140-053	BLACK PLASTIC ENGINE HEATER RECEPTACLE MOUNTED UNDER LH DOOR			N/C
132-004	ELECTRIC GRID AIR INTAKE WARMER			N/C
155-058	DELCO 12V 38MT HD STARTER WITH INTEGRATED MAGNETIC SWITCH	-35		N/C

Transmission

342-582	ALLISON 3000 RDS AUTOMATIC TRANSMISSION WITH PTO PROVISION			STD
---------	--	--	--	-----

Transmission Equipment

343-339	ALLISON VOCATIONAL PACKAGE 223 - AVAILABLE ON 3000/4000 PRODUCT FAMILIES WITH VOCATIONAL MODELS RDS, HS, MH AND TRV			STD
84B-002	ALLISON VOCATIONAL RATING FOR CONCRETE MIXER APPLICATIONS ONLY AVAILABLE WITH 3000 PRODUCT FAMILIES			STD
84C-023	PRIMARY MODE GEARS, LOWEST GEAR 1, START GEAR 1, HIGHEST GEAR 6, AVAILABLE FOR 3000/4000 PRODUCT FAMILIES ONLY			STD
84D-023	SECONDARY MODE GEARS, LOWEST GEAR 1, START GEAR 1, HIGHEST GEAR 6, AVAILABLE FOR 3000/4000 PRODUCT FAMILIES ONLY			STD



Prepared for:
 Marquita Blair
 Flint City Of
 702 W 12th St
 Flint, MI 48503
 Phone: 810-423-5650

Prepared by:
 Mike Denno
 D and K TRUCK COMPANY
 3020 Snow Rd
 LANSING, MI 48917
 Phone: 517-449-2329

Data Code	Description	Weight Front	Weight Rear	Retail Price
84E-000	PRIMARY SHIFT SCHEDULE RECOMMENDED BY DTNA AND ALLISON, THIS DEFINED BY ENGINE AND VOCATIONAL USAGE			STD
84F-000	SECONDARY SHIFT SCHEDULE RECOMMENDED BY DTNA AND ALLISON, THIS DEFINED BY ENGINE AND VOCATIONAL USAGE			STD
84G-000	PRIMARY SHIFT SPEED RECOMMENDED BY DTNA AND ALLISON, THIS DEFINED BY ENGINE AND VOCATIONAL USAGE			STD
84H-000	SECONDARY SHIFT SPEED RECOMMENDED BY DTNA AND ALLISON, THIS DEFINED BY ENGINE AND VOCATIONAL USAGE			STD
84J-000	ENGINE BRAKE RANGE PRESELECT RECOMMENDED BY DTNA AND ALLISON, THIS DEFINED BY ENGINE AND VOCATIONAL USAGE			STD
84K-002	2ND GEAR ENGINE BRAKE ALTERNATE PRESELECT WITH MODERATE DOWNSHIFT STRATEGY			STD
84N-200	FUEL SENSE 2.0 DISABLED - PERFORMANCE - TABLE BASED			STD
84U-000	DRIVER SWITCH INPUT - DEFAULT - NO SWITCHES			STD
84V-001	DIRECTION CHANGE ENABLED WITH MULTIPLEXED SERVICE BRAKES - ALLISON 5TH GEN TRANSMISSIONS			STD
353-076	QUICKFIT BODY LIGHTING CONNECTOR AT END OF FRAME, WITH BLUNTCUTS			\$530.00
34C-011	ELECTRONIC TRANSMISSION WIRING TO CUSTOMER INTERFACE CONNECTOR			\$95.00
362-2JT	CUSTOMER INSTALLED CHELSEA 281 SERIES PTO	50		N/C
363-001	PTO MOUNTING, LH SIDE OF MAIN TRANSMISSION ALLISON			N/C
341-018	MAGNETIC PLUGS, ENGINE DRAIN, TRANSMISSION DRAIN, AXLE(S) FILL AND DRAIN			STD
345-078	HEAVY DUTY ELECTRONIC TRANSMISSION SHIFT CONTROL, COLUMN MOUNTED			STD
97G-004	TRANSMISSION PROGNOSTICS - ENABLED 2013			STD
370-015	WATER TO OIL TRANSMISSION COOLER, IN RADIATOR END TANK	-15		N/C
346-003	TRANSMISSION OIL CHECK AND FILL WITH ELECTRONIC OIL LEVEL CHECK			STD
35T-001	ATF-SYNTHETIC AUTOMATIC TRANSMISSION FLUID			STD



Prepared for:
 Marquita Blair
 Flint City Of
 702 W 12th St
 Flint, MI 48503
 Phone: 810-423-5650

Prepared by:
 Mike Denno
 D and K TRUCK COMPANY
 3020 Snow Rd
 LANSING, MI 48917
 Phone: 517-449-2329

Data Code	Description	Weight Front	Weight Rear	Retail Price
Front Axle and Equipment				
400-1A9	DETROIT DA-F-16.0-5 16,000# FL1 71.0 KPI/3.74 DROP SINGLE FRONT AXLE	190		\$1,865.00
402-030	MERITOR 16.5X6 Q+ CAST SPIDER CAM FRONT BRAKES, DOUBLE ANCHOR, FABRICATED SHOES	10		N/C
403-002	NON-ASBESTOS FRONT BRAKE LINING			STD
419-003	MOTOR WHEEL CENTRIFUSE FRONT BRAKE DRUMS	-40		\$272.00
427-001	FRONT BRAKE DUST SHIELDS	5		\$102.00
409-006	FRONT OIL SEALS			STD
408-001	VENTED FRONT HUB CAPS WITH WINDOW, CENTER AND SIDE PLUGS - OIL			STD
416-022	STANDARD SPINDLE NUTS FOR ALL AXLES			STD
405-002	MERITOR AUTOMATIC FRONT SLACK ADJUSTERS			STD
406-001	STANDARD KING PIN BUSHINGS			STD
536-055	TRW THP-60 POWER STEERING WITH RCH45 AUXILIARY GEAR	130		\$1,142.00
539-003	POWER STEERING PUMP			STD
534-003	4 QUART POWER STEERING RESERVOIR			N/C
533-001	OIL/AIR POWER STEERING COOLER			N/C
40T-002	CURRENT AVAILABLE SYNTHETIC 75W-90 FRONT AXLE LUBE			\$17.00
Front Suspension				
620-026	16,000# TAPERLEAF FRONT SUSPENSION	200		\$1,151.00
619-005	MAINTENANCE FREE RUBBER BUSHINGS - FRONT SUSPENSION			STD
410-001	FRONT SHOCK ABSORBERS			STD
Rear Axle and Equipment				
420-1K3	MERITOR MT-40-14X 40,000# R-SERIES TANDEM REAR AXLE		-40	\$608.00
421-586	5.86 REAR AXLE RATIO			N/C
424-003	IRON REAR AXLE CARRIER WITH OPTIONAL HEAVY DUTY AXLE HOUSING		40	\$102.00
386-073	MXL 17T MERITOR EXTENDED LUBE MAIN DRIVELINE WITH HALF ROUND YOKES			STD
388-073	MXL 17T MERITOR EXTENDED LUBE INTERAXLE DRIVELINE WITH HALF ROUND YOKES			STD
452-006	DRIVER CONTROLLED TRACTION DIFFERENTIAL - BOTH TANDEM REAR AXLES		30	\$1,317.00



Prepared for:
 Marquita Blair
 Flint City Of
 702 W 12th St
 Flint, MI 48503
 Phone: 810-423-5650

Prepared by:
 Mike Denno
 D and K TRUCK COMPANY
 3020 Snow Rd
 LANSING, MI 48917
 Phone: 517-449-2329

Data Code	Description	Weight Front	Weight Rear	Retail Price
878-023	(1) INTERAXLE LOCK VALVE, (1) DRIVER CONTROLLED DIFFERENTIAL LOCK FORWARD-REAR AND REAR-REAR AXLE VALVE			N/C
87A-005	INDICATOR LIGHT FOR EACH INTERAXLE LOCKOUT SWITCH			N/C
87B-015	INDICATOR LIGHT FOR EACH DIFFERENTIAL LOCKOUT SWITCH, ENGAGE <5 MPH, DISENGAGE >25 MPH			N/C
423-020	MERITOR 16.5X7 Q+ CAST SPIDER CAM REAR BRAKES, DOUBLE ANCHOR, FABRICATED SHOES			STD
433-002	NON-ASBESTOS REAR BRAKE LINING			STD
434-019	ASPHALT SPREADER CLEARANCE REAR BRAKE GEOMETRY			N/C
451-027	CONMET CASTLITE CAST IRON REAR BRAKE DRUMS		-30	\$95.00
425-002	REAR BRAKE DUST SHIELDS		10	\$130.00
440-006	REAR OIL SEALS			STD
426-101	WABCO TRISTOP D LONGSTROKE 2-DRIVE AXLE SPRING PARKING CHAMBERS			STD
428-003	HALDEX AUTOMATIC REAR SLACK ADJUSTERS			\$93.00
41T-002	CURRENT AVAILABLE SYNTHETIC 75W-90 REAR AXLE LUBE			STD
42T-001	STANDARD REAR AXLE BREATHER(S)			STD
Rear Suspension				
622-311	HENDRICKSON HAULMAAX EX 40,000# REAR SUSPENSION		110	\$4,617.00
621-1AP	HENDRICKSON HAULMAAX/ULTIMAAX - 10.50" RIDE HEIGHT			N/C
624-011	52 INCH AXLE SPACING			STD
628-010	HENDRICKSON HN, HAULMAAX AND ULTIMAAX SERIES STEEL BEAMS WITH BAR PIN			N/C
623-016	STANDARD DUTY FORE/AFT AND HEAVY DUTY TRANSVERSE CONTROL RODS			N/C
625-008	DOUBLE REBOUND STRAP - INBOARD AND OUTBOARD		13	\$100.00
Pusher / Tag Equipment				
429-998	NO PUSHER/TAG BRAKE DUST SHIELDS			STD
Brake System				
490-100	WABCO 4S/4M ABS			(\$179.00)
871-001	REINFORCED NYLON, FABRIC BRAID AND WIRE BRAID CHASSIS AIR LINES			STD
46E-001	STANDARD AIR MANAGEMENT UNIT			STD



Prepared for:
 Marquita Blair
 Flint City Of
 702 W 12th St
 Flint, MI 48503
 Phone: 810-423-5650

Prepared by:
 Mike Denno
 D and K TRUCK COMPANY
 3020 Snow Rd
 LANSING, MI 48917
 Phone: 517-449-2329

Data Code	Description	Weight Front	Weight Rear	Retail Price	
904-001	FIBER BRAID PARKING BRAKE HOSE			STD	
412-001	STANDARD BRAKE SYSTEM VALVES			STD	
46D-002	STANDARD AIR SYSTEM PRESSURE PROTECTION SYSTEM			STD	
413-002	STD U.S. FRONT BRAKE VALVE			STD	
432-003	RELAY VALVE WITH 5-8 PSI CRACK PRESSURE, NO REAR PROPORTIONING VALVE			STD	
480-088	WABCO SYSTEM SAVER HP WITH INTEGRAL AIR GOVERNOR AND HEATER			STD	
483-004	WABCO OIL COALESCING FILTER FOR AIR DRYER			\$11.00	
479-004	AIR DRYER MOUNTED OUTBOARD ON LH RAIL AT BACK OF CAB			N/C	
460-1AE	STEEL AIR TANKS MOUNTED FOR MAX GROUND CLEARANCE, (BELLY PLOW - AA3-073)			\$165.00	
477-004	PULL CABLES ON ALL AIR RESERVOIR(S)			\$3.00	
Trailer Connections					
476-998	NO AIR HOSE HANGER			STD	
914-001	AIR CONNECTIONS TO END OF FRAME WITH GLAD HANDS FOR TRUCK AND NO DUST COVERS			N/C	
296-027	PRIMARY CONNECTOR/RECEPTACLE WIRED FOR COMBINATION STOP/TURN, CENTER PIN POWERED THROUGH IGNITION WITH STOP SIGNAL PREWIRE PACKAGE			\$59.00	
303-025	SAE J560 7-WAY PRIMARY TRAILER CABLE RECEPTACLE MOUNTED END OF FRAME			N/C	
30K-025	2-WAY HEAVY DUTY 150 AMP RECEPTACLE WIRED HOT, MOUNTED WITH PRIMARY RECEPTACLE			\$189.00	
N	1AZ-998			NO TRAILER RECEPTACLE BRACKET	STD
Wheelbase & Frame					
545-512	5125MM (202 INCH) WHEELBASE			N/C	
546-1B2	1/2X3.64X11-7/8 INCH STEEL FRAME (12.7MMX301.6MM/0.5X11.88 INCH) 120KSI	360	300	\$2,850.00	
547-034	PARTIAL INNER FRAME REINFORCEMENT AT FRONT SUSPENSION	180		\$1,060.00	
548-803	TEM TO EVALUATE AND INSTALL FRAME RAIL REINFORCEMENT AS NEEDED FOR FRONT FRAME MOUNTED EQUIPMENT			N/C	
552-014	1900MM (75 INCH) REAR FRAME OVERHANG			N/C	
55W-007	FRAME OVERHANG RANGE: 71 INCH TO 80 INCH	-20	110	N/C	
549-002	24 INCH INTEGRAL FRONT FRAME EXTENSION	140	-20	\$460.00	



Prepared for:
 Marquita Blair
 Flint City Of
 702 W 12th St
 Flint, MI 48503
 Phone: 810-423-5650

Prepared by:
 Mike Denno
 D and K TRUCK COMPANY
 3020 Snow Rd
 LANSING, MI 48917
 Phone: 517-449-2329

Data Code	Description	Weight Front	Weight Rear	Retail Price
AC8-99D	CALC'D BACK OF CAB TO REAR SUSP C/L (CA) : 136.22 in			
AE8-99D	CALCULATED EFFECTIVE BACK OF CAB TO REAR SUSPENSION C/L (CA) : 110.22 in			
AE4-99D	CALC'D FRAME LENGTH - OVERALL : 346.18 in			
FSS-0LH	CALCULATED FRAME SPACE LH SIDE : 42.43 in			N/C
FSS-0RH	CALCULATED FRAME SPACE RH SIDE : 82.1 in			N/C
AM6-99D	CALC'D SPACE AVAILABLE FOR DECKPLATE : 0.0 in			
553-001	SQUARE END OF FRAME			STD
587-003	REAR TOW HOOKS		10	\$160.00
550-001	FRONT CLOSING CROSSMEMBER			STD
559-001	STANDARD WEIGHT ENGINE CROSSMEMBER			STD
562-001	STANDARD MIDSHIP #1 CROSSMEMBER(S)			STD
572-001	STANDARD REARMOST CROSSMEMBER			STD
565-001	STANDARD SUSPENSION CROSSMEMBER			STD

Chassis Equipment

556-997	OMIT FRONT BUMPER, CUSTOMER INSTALLED SPECIAL BUMPER, DOES NOT COMPLY WITH FMCSR 393.203	-100		(\$294.00)
558-001	FRONT TOW HOOKS - FRAME MOUNTED	15		\$80.00
585-998	NO MUDFLAP BRACKETS			STD
590-998	NO REAR MUDFLAPS			STD
551-001	HUCK-SPIN ROUND COLLAR CHASSIS FASTENERS SUSPENSIONS ONLY			(\$77.00)
44Z-005	EXTERIOR HARNESES WRAPPED IN ABRASION TAPE, SECONDARY COVERING, & CONNECTOR PROTECTION			\$1,215.00
605-017	LEVEL FRAME RAILS (+1%, -0%) WHEN CHASSIS IS LOADED TO FRONT AND REAR SUSPENSION RATINGS			\$140.00

Fifth Wheel

578-998	NO FIFTH WHEEL			STD
---------	----------------	--	--	-----

Fuel Tanks

*	204-151	60 GALLON/227 LITER ALUMINUM FUEL TANK - LH		STD
		FUEL TANK WILL BE REMOVED BY BODY COMPANY & NEED DEF TANK JUST AFT OF LH FRONT WHEEL-BODY COMPANY WILL BUILD STEPS		
N	218-006	25 INCH DIAMETER FUEL TANK(S)		STD
	215-005	PLAIN ALUMINUM/PAINTED STEEL FUEL/HYDRAULIC TANK(S) WITH PAINTED BANDS		STD



Prepared for:
 Marquita Blair
 Flint City Of
 702 W 12th St
 Flint, MI 48503
 Phone: 810-423-5650

Prepared by:
 Mike Denno
 D and K TRUCK COMPANY
 3020 Snow Rd
 LANSING, MI 48917
 Phone: 517-449-2329

	Data Code	Description	Weight Front	Weight Rear	Retail Price
N	212-007	FUEL TANK(S) FORWARD			STD
	664-001	PLAIN STEP FINISH			STD
	205-001	FUEL TANK CAP(S)			STD
	122-1H3	DETROIT FUEL/WATER SEPARATOR WITH WATER IN FUEL SENSOR	10		N/C
	216-020	EQUIFLO INBOARD FUEL SYSTEM			STD
	202-016	HIGH TEMPERATURE REINFORCED NYLON FUEL LINE			STD
Tires					
	093-1YU	CONTINENTAL HAU 3 WT 315/80R22.5 20 PLY RADIAL FRONT TIRES	100		\$930.00
	094-1YV	CONTINENTAL INTELLIGENT HDC3 11R22.5 16 PLY RADIAL REAR TIRES		192	\$1,240.00
Hubs					
	418-060	CONMET PRESET PLUS PREMIUM IRON FRONT HUBS			STD
	450-060	CONMET PRESET PLUS PREMIUM IRON REAR HUBS			STD
Wheels					
	502-433	ACCURIDE 29039 22.5X9.00 10-HUB PILOT 5.25 INSET 5-HAND STEEL DISC FRONT WHEELS	66		\$220.00
	505-428	ACCURIDE 28828 22.5X8.25 10-HUB PILOT 2-HAND HD STEEL DISC REAR WHEELS		104	STD
	496-011	FRONT WHEEL MOUNTING NUTS			STD
	497-011	REAR WHEEL MOUNTING NUTS			STD
	498-011	NYLON WHEEL GUARDS FRONT AND REAR ALL INTERFACES			\$68.00
Cab Exterior					
	829-1A2	114 INCH BBC FLAT ROOF ALUMINUM CONVENTIONAL CAB			STD
	650-008	AIR CAB MOUNTING			STD
	705-012	CAB ROOF REINFORCEMENTS FOR ROOF MOUNTED COMPONENTS	2		\$87.00
	648-002	NONREMOVABLE BUGSCREEN MOUNTED BEHIND GRILLE			STD
	667-037	SHORT FENDER WITH MUDFLAP			\$141.00
	754-017	BOLT-ON MOLDED FLEXIBLE FENDER EXTENSIONS	10		\$115.00
	678-001	LH AND RH GRAB HANDLES			STD
	646-041	STATIONARY BLACK GRILLE			STD
	65X-004	BLACK HOOD MOUNTED AIR INTAKE GRILLE			STD



Prepared for:
 Marquita Blair
 Flint City Of
 702 W 12th St
 Flint, MI 48503
 Phone: 810-423-5650

Prepared by:
 Mike Denno
 D and K TRUCK COMPANY
 3020 Snow Rd
 LANSING, MI 48917
 Phone: 517-449-2329

Data Code	Description	Weight Front	Weight Rear	Retail Price
644-004	FIBERGLASS HOOD			STD
652-001	FREIGHTLINER NAME PLATES			STD
690-017	HOOD LINER, ADDED FIREWALL AND FLOOR HEAT INSULATION	5		\$117.00
727-1AM	DUAL 24 INCH ROUND POLISHED ALUMINUM AIR HORNS ROOF MOUNTED	4		\$150.00
726-001	SINGLE ELECTRIC HORN			STD
728-002	DUAL HORN SHIELDS			N/C
575-001	REAR LICENSE PLATE MOUNT END OF FRAME			STD
327-005	DUAL AMBER ELECTRONIC STROBE LIGHTS WITH STAINLESS STEEL BRACKETS	20		\$1,320.00
312-068	HALOGEN COMPOSITE HEADLAMPS WITH BLACK BEZELS			STD
302-047	LED AERODYNAMIC MARKER LIGHTS			STD
314-824	WIRING AND SWITCH FOR CUSTOMER FURNISHED SNOW PLOW LAMPS WITH DUAL CONNECTIONS AT BUMPER			\$162.00
311-998	NO DAYTIME RUNNING LIGHTS			(\$21.00)
294-001	INTEGRAL STOP/TAIL/BACKUP LIGHTS			STD
300-015	STANDARD FRONT TURN SIGNAL LAMPS			STD
744-1BC	DUAL WEST COAST BRIGHT FINISH HEATED MIRRORS WITH LH AND RH REMOTE			\$133.00
797-001	DOOR MOUNTED MIRRORS			STD
796-001	102 INCH EQUIPMENT WIDTH			STD
743-204	LH AND RH 8 INCH BRIGHT FINISH CONVEX MIRRORS MOUNTED UNDER PRIMARY MIRRORS			N/C
729-001	STANDARD SIDE/REAR REFLECTORS			STD
677-062	FIXED CAB MOUNTED STEPS LH AND RH FOR CAB ENTRY, BELLY PLOW BODY WITH HIGH GROUND CLEARANCE DOES NOT COMPLY FMCSR 399			\$106.00
768-043	63X14 INCH TINTED REAR WINDOW			STD
661-003	TINTED DOOR GLASS LH AND RH WITH TINTED NON-OPERATING WING WINDOWS			(\$117.00)
654-011	RH AND LH ELECTRIC POWERED WINDOWS			STD
663-029	1-PIECE BONDED HEATED WIPER PARK SOLAR GREEN GLASS WINDSHIELD			\$423.00
659-019	2 GALLON WINDSHIELD WASHER RESERVOIR WITHOUT FLUID LEVEL INDICATOR, FRAME MOUNTED			(\$80.00)
647-001	WHITE WINTERFRONT	2		\$60.00



Prepared for:
 Marquita Blair
 Flint City Of
 702 W 12th St
 Flint, MI 48503
 Phone: 810-423-5650

Prepared by:
 Mike Denno
 D and K TRUCK COMPANY
 3020 Snow Rd
 LANSING, MI 48917
 Phone: 517-449-2329

Data Code	Description	Weight Front	Weight Rear	Retail Price
Cab Interior				
055-018	ELITE TRIM PACKAGE			N/C
707-106	MIST CLOTH & CARBON VINYL INTERIOR "ELITE"			N/C
70K-019	CARBON WITH PREMIUM WOOD ACCENT (ELITE)			\$16.00
706-013	MOLDED DOOR PANEL			STD
708-013	MOLDED PLASTIC DOOR PANEL			STD
772-006	BLACK MATS WITH SINGLE INSULATION			STD
785-026	(1)DASH MOUNTED 12V POWER OUTLET, (1)DASH MOUNTED DUAL USB-C OUTLET			\$45.00
691-001	FORWARD ROOF MOUNTED CONSOLE			STD
696-012	CENTER STORAGE CONSOLE MOUNTED ON BACKWALL	20		\$26.00
693-035	LH AND RH KICKPLATES			\$131.00
738-021	DIGITAL ALARM CLOCK IN DRIVER DISPLAY			STD
742-007	(2) CUP HOLDERS LH AND RH DASH			STD
680-029	M2/SD DASH			STD
700-002	HEATER, DEFROSTER AND AIR CONDITIONER			STD
701-008	STANDARD HVAC DUCTING WITH SNOW SHIELD FOR FRESH AIR INTAKE			\$31.00
703-005	MAIN HVAC CONTROLS WITH RECIRCULATION SWITCH			STD
170-015	STANDARD HEATER PLUMBING			STD
130-041	VALEO HEAVY DUTY A/C REFRIGERANT COMPRESSOR			STD
702-002	BINARY CONTROL, R-134A			STD
739-034	PREMIUM INSULATION			\$145.00
285-013	SOLID-STATE CIRCUIT PROTECTION AND FUSES			STD
280-007	12V NEGATIVE GROUND ELECTRICAL SYSTEM			STD
324-1B3	STANDARD LED CAB LIGHTING			STD
787-998	NO SECURITY DEVICE			N/C
657-1A0	ALL UNIT(S) KEYED ALIKE WITH CUSTOMER SPECIFIED KEY NUMBER FT1013			\$43.00
78G-003	KEY QUANTITY OF 3			\$9.00
655-028	LH AND RH ELECTRIC DOOR LOCKS WITH AUTO UNLOCK FEATURE WHEN DOOR IS SET FROM OPEN TO CLOSED POSITION			\$23.00
740-998	NO MATTRESS	-20	-15	STD



Prepared for:
 Marquita Blair
 Flint City Of
 702 W 12th St
 Flint, MI 48503
 Phone: 810-423-5650

Prepared by:
 Mike Denno
 D and K TRUCK COMPANY
 3020 Snow Rd
 LANSING, MI 48917
 Phone: 517-449-2329

Data Code	Description	Weight Front	Weight Rear	Retail Price
756-338	BASIC ISRINGHAUSEN HIGH BACK AIR SUSPENSION DRIVERS SEAT WITH MECHANICAL LUMBAR AND INTEGRATED CUSHION EXTENSION	30		\$320.00
760-337	BASIC ISRINGHAUSEN HIGH BACK NON SUSPENSION TOOL BOX PASSENGER SEAT			\$195.00
759-007	DUAL DRIVER SEAT ARMRESTS, NO PASSENGER SEAT ARMRESTS	4		\$69.00
711-004	LH AND RH INTEGRAL DOOR PANEL ARMRESTS			STD
758-022	BLACK MORDURA CLOTH DRIVER SEAT COVER			(\$53.00)
761-023	BLACK MORDURA CLOTH PASSENGER SEAT COVER			(\$52.00)
763-102	HIGH VISIBILITY ORANGE SEAT BELTS			\$26.00
532-002	ADJUSTABLE TILT AND TELESCOPING STEERING COLUMN			STD
540-070	4-SPOKE 18 INCH (450MM) LEATHER WRAPPED STEERING WHEEL WITH CHROME SWITCH BEZELS			STD
765-002	DRIVER AND PASSENGER INTERIOR SUN VISORS			STD

Instruments & Controls

4CH-006	6 EXTRA PROGRAMMABLE SWITCHES/INDICATORS			\$135.00
	\$C1B0082ZZ,C1C0083ZZ,C1D0084ZZ,C1E0085ZZ,C1F0176ZZ,C1G0177ZZ			
106-002	ELECTRONIC ACCELERATOR CONTROL			STD
732-998	NO INSTRUMENT PANEL-DRIVER			STD
734-022	FULLY CONFIGURABLE CENTER INSTRUMENT PANELS			STD
87L-001	ENGINE PTO SPEED CONTROL WITH PARK BRAKE INTERLOCK			N/C
870-002	BRIGHT ARGENT FINISH GAUGE BEZELS			STD
486-001	LOW AIR PRESSURE INDICATOR LIGHT AND AUDIBLE ALARM			STD
840-001	DUAL NEEDLE PRIMARY AND SECONDARY AIR PRESSURE GAUGE			STD
198-025	INTAKE MOUNTED AIR RESTRICTION INDICATOR WITHOUT GRADUATIONS			STD
149-015	ELECTRONIC CRUISE CONTROL WITH CONTROLS ON STEERING WHEEL SPOKES			STD
156-007	KEY OPERATED IGNITION SWITCH AND INTEGRAL START POSITION; 4 POSITION OFF/RUN/START/ACCESSORY			STD
811-044	PREMIUM INSTRUMENT CLUSTER WITH 5.0 INCH TFT COLOR DISPLAY			STD



Prepared for:
 Marquita Blair
 Flint City Of
 702 W 12th St
 Flint, MI 48503
 Phone: 810-423-5650

Prepared by:
 Mike Denno
 D and K TRUCK COMPANY
 3020 Snow Rd
 LANSING, MI 48917
 Phone: 517-449-2329

	Data Code	Description	Weight Front	Weight Rear	Retail Price
	81B-003	DIGITAL PANEL LAMP DIMMER SWITCH IN DRIVER DISPLAY			STD
	160-038	HEAVY DUTY ONBOARD DIAGNOSTICS INTERFACE CONNECTOR LOCATED BELOW LH DASH			STD
	844-001	2 INCH ELECTRIC FUEL GAUGE			STD
N	148-072	ENGINE REMOTE INTERFACE WITH ONE OR MORE SET SPEEDS			\$134.00
	48H-001	QUICKFIT POWERTRAIN INTERFACE CONNECTOR LOCATED BETWEEN SEATS WITH CAPS			\$150.00
	48C-001	QUICKFIT PROGRAMMABLE INTERFACE CONNECTOR(S) BETWEEN SEATS WITH CAP			N/C
	163-014	ENGINE REMOTE INTERFACE CONNECTOR AT POWERTRAIN INTERFACE CONNECTOR			N/C
	856-001	ELECTRICAL ENGINE COOLANT TEMPERATURE GAUGE			STD
	852-002	ELECTRIC ENGINE OIL PRESSURE GAUGE			STD
	864-001	2 INCH TRANSMISSION OIL TEMPERATURE GAUGE			\$30.00
	867-004	ELECTRONIC OUTSIDE TEMPERATURE SENSOR DISPLAY IN DRIVER MESSAGE CENTER			STD
	830-017	ENGINE AND TRIP HOUR METERS INTEGRAL WITHIN DRIVER DISPLAY			STD
	372-123	PTO CONTROLS FOR ENHANCED VEHICLE ELECTRIC/ELECTRONIC ARCHITECTURE			\$60.00
	736-998	NO OBSTACLE DETECTION SYSTEM			(\$4,324.00)
	72J-998	NO DR ASSIST SYSTEM			N/C
	49B-998	NO VEHICLE STABILITY ADVISOR OR CONTROL			(\$1,019.00)
	73B-998	NO LANE DEPARTURE WARNING SYSTEM			(\$1,080.00)
	679-998	NO OVERHEAD INSTRUMENT PANEL			STD
	35M-012	1 QUIKFIT PROGRAMABLE MODULE (QPMXMC) W/ (8) 20AMP FUSED RELAYS			\$935.00
	746-143	7" B-PANEL INTERACTIVE TOUCHSCREEN DISPLAY RADIO W/ USB-C, APPLE CARPLAY, ANDROID AUTO, BLUETOOTH/AM/FM/SXM/WB, WITH MICROPHONE			STD
	747-001	DASH MOUNTED RADIO			STD
	750-002	(2) RADIO SPEAKERS IN CAB			STD
	753-998	NO AM/FM RADIO ANTENNA			STD
	748-006	POWER AND GROUND WIRING PROVISION OVERHEAD			N/C



Prepared for:
 Marquita Blair
 Flint City Of
 702 W 12th St
 Flint, MI 48503
 Phone: 810-423-5650

Prepared by:
 Mike Denno
 D and K TRUCK COMPANY
 3020 Snow Rd
 LANSING, MI 48917
 Phone: 517-449-2329

Data Code	Description	Weight Front	Weight Rear	Retail Price
749-001	ROOF/OVERHEAD CONSOLE CB RADIO PROVISION			N/C
752-071	SPRING MOUNTED SINGLE FIBERGLASS LH MIRROR MOUNTED CB ANTENNA WITH BRACKET AND LEAD	2		\$48.00
75W-006	SHARKFIN MULTI-BAND ANTENNA, CENTRAL ROOF MOUNTING LOCATION: AM/FM/WEATHERBAND, WIFI/BLUETOOTH, SDAR/SIRIUSXM, GNSS/GPS			\$5.00
78C-003	INTEROPERABLE SDAR ANTENNA			STD
810-027	ELECTRONIC MPH SPEEDOMETER WITH SECONDARY KPH SCALE, WITHOUT ODOMETER			STD
817-001	STANDARD VEHICLE SPEED SENSOR			STD
812-001	ELECTRONIC 3000 RPM TACHOMETER			STD
813-1C8	DETROIT CONNECT PLATFORM HARDWARE			STD
8D1-313	3 YEARS DAIMLER CONNECTIVITY BASE PACKAGE ON (FEATURES VARY BY MODEL) POWERED BY DETROIT CONNECT ON CUMMINS ENGINES			N/C
6TS-005	TMC RP1226 ACCESSORY CONNECTOR LOCATED BEHIND PASSENGER SIDE REMOVEABLE DASH PANEL			STD
162-002	IGNITION SWITCH CONTROLLED ENGINE STOP			STD
81Y-005	PRE-TRIP INSPECTION FEATURE FOR EXTERIOR LAMPS ONLY			\$43.00
264-030	(1) OVERHEAD MOUNTED LANYARD CONTROL FOR DRIVER AIR HORN			STD
482-001	STANDARD TRACTOR PROTECTION VALVE			N/C
883-001	TRAILER HAND CONTROL BRAKE VALVE			N/C
842-006	DIGITAL TURBO AIR PRESSURE IN DRIVER DISPLAY			N/C
836-015	DIGITAL VOLTAGE DISPLAY INTEGRAL WITH DRIVER DISPLAY			STD
660-008	SINGLE ELECTRIC WINDSHIELD WIPER MOTOR WITH DELAY			STD
304-030	ROTARY HEADLAMP SWITCH, MARKER LIGHTS/HEADLIGHTS SWITCH WITH PULL OUT FOR OPTIONAL FOG/ROAD LAMPS			N/C
882-021	TWO VALVE PARKING BRAKE SYSTEM WITH DASH VALVE CONTROL AUTONEUTRAL AND WARNING INDICATOR			\$13.00
299-020	SELF CANCELING TURN SIGNAL SWITCH WITH DIMMER, HEADLAMP FLASH, WASH/WIPE/INTERMITTENT			STD



Prepared for:
 Marquita Blair
 Flint City Of
 702 W 12th St
 Flint, MI 48503
 Phone: 810-423-5650

Prepared by:
 Mike Denno
 D and K TRUCK COMPANY
 3020 Snow Rd
 LANSING, MI 48917
 Phone: 517-449-2329

Data Code	Description	Weight Front	Weight Rear	Retail Price
298-046	INTEGRAL ELECTRONIC TURN SIGNAL FLASHER WITH 40 AMP (20 AMP PER SIDE) TRAILER LAMP CAPACITY			STD
87T-998	NO WRG/SW-OPTL #2,CHAS,AIR			STD
Design				
065-000	PAINT: ONE SOLID COLOR			STD
Color				
980-5D8	CAB COLOR A: L0753EY RED ELITE EY			N/C
986-020	BLACK, HIGH SOLIDS POLYURETHANE CHASSIS PAINT			STD
962-972	POWDER WHITE (N0006EA) FRONT WHEELS/RIMS (PKWHT21, TKWHT21, W, TW)			STD
966-972	POWDER WHITE (N0006EA) REAR WHEELS/RIMS (PKWHT21, TKWHT21, W, TW)			STD
963-003	STANDARD E COAT/UNDERCOATING			STD
Certification / Compliance				
996-001	U.S. FMVSS CERTIFICATION, EXCEPT SALES CABS AND GLIDER KITS			STD

Weight Summary

	Weight Front	Weight Rear	Total Weight
Factory Weight*	8973 lbs	6790 lbs	15763 lbs
Dealer Installed Options	0 lbs	0 lbs	0 lbs
Total Weight*	8973 lbs	6790 lbs	15763 lbs

Dealer Installed Options

	Weight Front	Weight Rear	Price
PREP DEALER PRE DELIVERY INSPECTION	0	0	\$740.00
Total Dealer Installed Options	0 lbs	0 lbs	\$740.00

(+) Weights shown are estimates only.

If weight is critical, contact Customer Application Engineering.

(**) Prices shown do not include taxes, fees, etc... "Net Equipment Selling Price" is located on the Quotation Details Proposal Report.

(***) All cost increases for major components (Engines, Transmissions, Axles, Front and Rear Tires) and government mandated requirements, tariffs, and raw material surcharges will be passed through and added to factory invoices.



Prepared for:
 Marquita Blair
 Flint City Of
 702 W 12th St
 Flint, MI 48503
 Phone: 810-423-5650

Prepared by:
 Mike Denno
 D and K TRUCK COMPANY
 3020 Snow Rd
 LANSING, MI 48917
 Phone: 517-449-2329

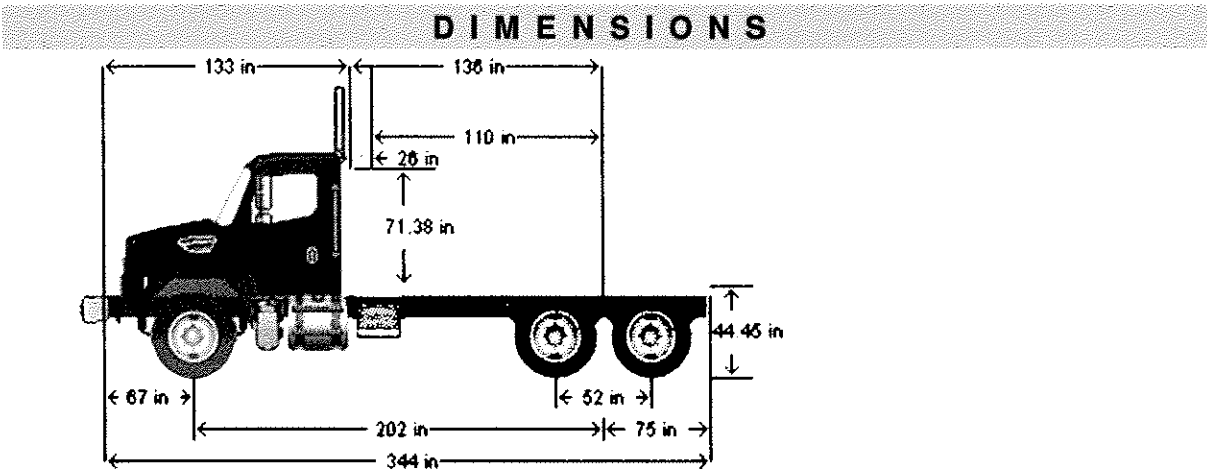

TABLE SUMMARY - DIMENSIONS

Dimensions	Inches
Bumper to Back of Cab (BBC)	132.9
Bumper to Centerline of Front Axle (BA)	67.3
Front Axle to Back of Cab (AC)	65.6
Min. Cab to Body Clearance (CB)	26.0
Back of Cab to Centerline of Rear Axle(s) (CA)	136.2
Effective Back of Cab to Centerline of Rear Axle(s) (Effective CA)	110.2
Back of Cab Protrusions (Exhaust/Intake) (CP)	2.0
Back of Cab Protrusions (Side Extenders/Trim Tab) (CP)	0.0
Back of Cab Protrusions (CNG Tank)	0.0
Back of Cab Clearance (CL)	26.0
Back of Cab to End of Frame	211.0
Cab Height (CH)	71.4
Wheelbase (WB)	201.8
Frame Overhang (OH)	74.8
Overall Frame Length	346.2
Overall Length (OAL)	343.9
Rear Axle Spacing	52.0
Unladen Frame Height at Centerline of Rear Axle	44.5

Performance calculations are estimates only. If performance calculations are critical, please contact Customer Application Engineering.



Prepared for:
Marquita Blair
Flint City Of
702 W 12th St
Flint, MI 48503
Phone: 810-423-5650

Prepared by:
Mike Denno
D and K TRUCK COMPANY
3020 Snow Rd
LANSING, MI 48917
Phone: 517-449-2329

SWITCH SELECTOR - 4CH - DASH PANEL

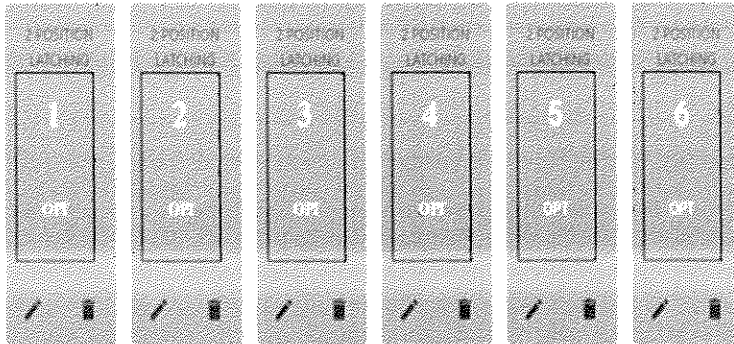

K--ANGB BATTLE CREEK, MI DUMPTRUCK SNOW REMOVAL CONVERSION

● Inactive

Notice ID	Contract Opportunity Type	Inactive Dates	Response Date
W50S84-21-Q-0020	Award Notice	Feb 13, 2022	(blank)
Related Notice	Contract Line Item Number	Inactive Policy	Published Date
W50S84-21-Q-0020	(blank)	Manual	Sep 08, 2021 3:48 PM EST

Department/Ind. Agency	Sub-tier	Major Command	Sub Command 1, 2, 3
DEPT OF DEFENSE	DEPT OF THE ARMY	NATIONAL GUARD BUREAU	JFHQ USPFO MI
Office			USPFO MI PROCUREMENT
W7NF USPFO ACTIVITY MI ARNG			

Award Details

Contract Award Date	Contract Award Number	Contractor Awarded Name
Sep 08, 2021	W50S8421P0003	TRUCK & TRAILER SPECIALTIES, INC. [DUNS: 065844185],3286 Hanna Lake Industrial Drive,Dutton MI 49316
Task/Delivery Order Number:	Contractor Awarded Address	Contractor Awarded Unique Entity ID
(blank)	,	(blank)
		Base and All Options Value (Total Contract Value)
		\$44,776.16



Home

Search

Forms

Business Trademark

CONNECTICUT GOVERNMENT SERVICES

Business Search

As of 5/7/2026:

- Business Filings are processed through 05/22/2026.
- Renewals and Restorations for entities returning to good standing are processed through 05/25/2026.

To file a document or annual report/statement for an existing entity, search for the entity, select Request Access from the slide-out drawer, complete the questions, refresh the webpage, and select File Subsequent Document or File Annual Report/Statement.

The same process applies to order certificates and copies.

You must be logged in to file documents or order certificates and copies. Click on the Login button in the top right. If you do not have an account, create one. The credentials from the previous system did not transfer to this system.

Business Search Info:

Truck and Trailer specialties

Name	Filing Date	Status	AR Standing	Entity Type	Entity ID#	Agent	AR Due Date
TRUCK AND TRAILER SPECIALTIES OF BOYNE FALLS, INC	09/25/1996	Active	Good	Domestic Profit Corporation	800427262	ALDWIN E CONE	05/15/2027
TRUCK AND TRAILER SPECIALTIES, INC	08/07/1984	Active	Good	Domestic Profit Corporation	800364098	DANIEL BOUWMAN	05/15/2027

Advanced

Results: 2

TRUCK AND TRAILER SPECIALTIES, INC

Entity Name: TRUCK AND TRAILER SPECIALTIES, INC

Identification #: 800364098

Jurisdiction: Michigan

Entity Type: Domestic Profit Corporation

Status: Active

AR Standing: Good

Common Shares: 50000

AR Due Date: 05/15/2027

Initial Filing Date: 08/07/1984

Last Report with Officers and Directors: 2026

Resident Agent Name: DANIEL BOUWMAN

Resident Agent Street Address: 6726 HANNA LAKE RD, SE, DUTTON, MI 488316

Registered Office Mailing Address: 3286 HANNA LAKE INDUSTRIAL PARK, DUTTON, MI 488316

Registered Agent Address: DANIEL BOUWMAN, 6726 HANNA LAKE RD, SE, DUTTON, MI 488316

Secretary Name Address: DANIEL BOUWMAN, 6726 HANNA LAKE RD, SE, DUTTON, MI 488316

Treasurer Name Address: DANIEL BOUWMAN, 6726 HANNA LAKE RD, SE, DUTTON, MI 488316

Director Name Address: DANIEL BOUWMAN, 6726 HANNA LAKE RD, SE, DUTTON, MI 488316



View History & Filings



RESOLUTION NO.: 260224

PRESENTED: 6-17-2026

ADOPTED: _____

Bid 26000011

BY THE CITY ADMINISTRATOR:

RESOLUTION TO AWARD PURCHASE ORDERS TO ACE SAGINAW PAVING COMPANY FOR ASPHALT PAVING MATERIALS IN AN AMOUNT NOT-TO-EXCEED \$2,497,150.00

The Division of Purchases and Supplies solicited bids for asphalt paving materials and Ace Saginaw Paving Company, 115 S. Averill Ave., Flint, Michigan was the lowest responsive bidder for said services, and

The Department of Public Works is requesting to enter into a pricing agreement for FY26 with Ace Saginaw Paving Company for asphalt paving materials for the City of Flint. Funding will come from the following accounts:

Account Number	Account Name	Amount
202-449.201-782.000	Asphalt – routine major	\$ 787,500.00
203-449.201-782.000	Asphalt – routine local	\$1,575,000.00
202-449.203-782.000	Asphalt – winter major	\$21,000.00
203-449.203-782.000	Asphalt – winter local	\$13,650.00
590-540.208-782.000	Asphalt – sewer	\$50,000.00
591-540.202-782.000	Asphalt - water	\$50,000.00
	FY27 GRAND TOTAL	\$2,497,150.00

For the accounts listed, the amounts cannot exceed the dollar amount assigned to the different activities.

IT IS RESOLVED, that the Division of Purchases & Supplies is hereby authorized to issue purchase orders to Ace Saginaw Paving Company for asphalt paving materials for FY27, in the amount not-to-exceed \$2,497,150.00.

FOR THE CITY OF FLINT:



Clyde Edwards, City Administrator

APPROVED BY CITY COUNCIL:

APPROVED AS TO FORM:

JoAnne Gurley
City Attorney

APPROVED AS TO FINANCE:

Phillip Moore
Chief Finance Officer

APPROVED AS TO PURCHASING:

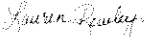
Lauren Rowley, Purchasing Manager

FY27 - KRN



STAFF REVIEW FORM

Effective: April 1, 2026

(Do not alter or modify this form without written permission from the City Administrator)

TODAY'S DATE: June 5, 2026

BID PROPOSAL #: Bid 26000011

AGENDA ITEM TITLE: Asphalt paving materials

PREPARED BY: Kathryn Neumann

VENDOR NAME: Ace-Saginaw Paving Co.

Section 1. BACKGROUND/SUMMARY OF PROPOSED ACTION..

Vendor Compliance (This vendor has been properly vetted and the responses are below) :

Federal gov't	(All documentation current, no violations)	<input checked="" type="checkbox"/> YES	<input type="checkbox"/> NO
State gov't	(All documentation current, no violations)	<input checked="" type="checkbox"/> YES	<input type="checkbox"/> NO
City of Flint	(All documentation current, no violations)	<input checked="" type="checkbox"/> YES	<input type="checkbox"/> NO

The requesting authority is validating that this vendor has been in full compliance with all past contract provisions and has not violated the terms of any contract with the City of Flint.

NOTE: Preparer **MUST** include a response to the conditions below:

- Did we do an assessment of first consideration to internal City of Flint staff and resources (explain)?
- Why was this vendor chosen?
- What history does this vendor have with the City of Flint?
- What steps will be taken to do a post-performance of the vendor?

The City purchases asphalt paving material used in filling potholes, paving roads and other tasks. Bids were solicited and Ace Saginaw Asphalt was the lowest responsive bidder. Ajax Paving Materials also supplied a bid, but they were a "no bid" on equipment rentals. Ace Saginaw Asphalt has been a vendor for the City of Flint for many years, they currently supply cold and hot patch materials to the City's crews. They have also paved roads for us in the past, and they are the current vendor for paving several major roads.

PROCUREMENT (MUST BE SPECIFIED)

Please specify how this vendor was identified: (Check one)

- Sole Source (Please attach sole source statement to requisition)
- Competitive Bid Process (Please attach bid tabulation/documents to requisition)
- Cooperative Contract (MIDeal, Sourcewell, GSA, or other municipality)
*Contract must be attached to your requisition and contract must appear on the vendor's quote for goods/services
- (3) Quotes (please attach all quotes to your requisition)

Section 2. PREVIOUS ALLOCATIONS (INCLUDE ALL ACCOUNTS USED FOR THIS PURPOSE)/ PROVIDE RESOLUTION OR CONTRACT INFORMATION THAT APPLIES..



STAFF REVIEW FORM

Effective: April 1, 2026

(Do not alter or modify this form without written permission from the City Administrator)

Fiscal Year	Account	PO Number	FY PO Amount	FY Expensed	Resolution
FY26	202-449.201-801.000	26-009466	\$2,000,000	0	260110
FY26	202&203-449.201-782.000	26-008537	\$2,455,150	\$915,255	250257-T
FY25	202&203-449.201-782.000	25-007487	\$2,341,000	\$1,426,47	240250
FY24	202&203-449.201-782.000	24-006121	\$2,184,300	\$1,475,806	230192
FY23	202&203-449.201-782.000	23-005410	\$1,248,025	\$1,097,698	210448

**Section 3. POSSIBLE BENEFIT TO THE CITY OF FLINT (RESIDENTS AND/OR CITY OPERATIONS)
INCLUDE PARTNERSHIPS AND COLLABORATIONS..**

Filling potholes immediately enhances public safety, protects vehicles from expensive damages, and prevents further structural breakdown of the pavement. Taking early action to fix minor road cavities blocks water infiltration, which is the primary driver of rapid asphalt deterioration.

Section 4. FINANCIAL IMPLICATIONS..

IF ARPA related Expenditure:

Has this request been reviewed by E&Y Firm: YES NO IF NO, PLEASE EXPLAIN:

NOTE: Accountant MUST include the following information:

- What is the total amount budgeted for this purpose?
- What percentage is being spent with this vendor?
- What is the justification for spending this amount of money with this vendor?
- What percentage is being spent out of each line item used in this request?
- List all the known budgeted funds from that line item.

- 202-449.201-782.000 total budget is \$787,500.00, total purchase amount is \$787,500.00, which is 100.00% of the total line item budget.



STAFF REVIEW FORM

Effective: April 1, 2026

(Do not alter or modify this form without written permission from the City Administrator)

- 203-449.201-782.000 total budget is \$1,575,000.00, total purchase amount is \$1,575,000.00, which is 100.00% of the total line item budget.
- 202-449.203-782.000 total budget is \$21,000.00, total purchase amount is \$21,000.00, which is 100.00% of the total line item budget.
- 203-449.203-782.000 total budget is \$13,650.00, total purchase amount is \$13,650.00, which is 100.00% of the total line item budget.
- 590-540.208-782.000 total budget is \$75,000.00, total purchase amount is \$50,000.00, which is 66.67% of the total line item budget.
- 591-540.202-782.000 total budget is \$75,000.00, total purchase amount is \$50,000.00, which is 66.67% of the total line item budget.

BUDGETED EXPENDITURE? YES NO IF NO, PLEASE EXPLAIN:

Dept.	Name of Account	Account Number	Grant CODE	Amount
Streets	Asphalt	202-449.201-782.000		\$787,500.00
Streets	Asphalt	203-449.201-782.000		\$1,575,000.00
Streets	Asphalt	202-449.203-782.000		\$21,000.00
Streets	Asphalt	203-449.203-782.000		\$13,650.00
WSC	Asphalt	590-540.208-782.000		\$50,000.00
WSC	Asphalt	591-540.202-782.000		\$50,000.00
FY27 GRAND TOTAL				\$ 2,497,150.00

WHEN APPLICABLE, IF MORE THAN ONE (1) YEAR, PLEASE ESTIMATE TOTAL AMOUNT FOR EACH BUDGET YEAR: (This will depend on the term of the bid proposal)

BUDGET YEAR 1: _____

BUDGET YEAR 2: _____

BUDGET YEAR 3: _____

OTHER IMPLICATIONS (i.e., collective bargaining).. _____

PRE-ENCUMBERED? YES NO REQUISITION NO: 270011549, 2600011563

ACCOUNTING APPROVAL: ggr Date: _____

WILL YOUR DEPARTMENT NEED A CONTRACT? YES NO

Section 5. RESOLUTION DEFENSE TEAM..

(Place the names of those who can defend this resolution at City Council)



STAFF REVIEW FORM

Effective: April 1, 2026

(Do not alter or modify this form without written permission from the City Administrator)

	NAME	PHONE NUMBER
1	Danny Schiller	810 691-4788
2		
3		
4		

STAFF RECOMMENDATION: (PLEASE SELECT): APPROVED NOT APPROVED

DEPARTMENT HEAD SIGNATURE:

Dan Schiller

Dan Schiller (Jun 5, 2026 12:54:20 EDT)

(Danny Schiller, Provisional Director of Transportation)

ADMINISTRATION APPROVAL:

(\$20,000 or above spending authorizations)

CDE

Clyde Edwards (Jun 5, 2026 14:42:10 EDT)

Section 6. VENDOR EVALUATION..

Business Title:

Ace Saginaw Paving Co.

Vendor ID:

000004863

Review Period:

Department:

Street Maintenance

Project Name:

Asphalt paving materials

Project Type:

Supplies

Vendor Goals:

To sell the City a quality product.

1 = Poor 2 = Fair 3 = Sufficient 4 = Good 5 = Excellent

Job Knowledge:

Work Quality:

Timeliness:

Compliance with Contract:



STAFF REVIEW FORM

Effective: April 1, 2026

(Do not alter or modify this form without written permission from the City Administrator)

Warranty (If Product):	<input type="checkbox"/>	<input type="checkbox"/>	<input type="checkbox"/>	<input checked="" type="checkbox"/>	<input type="checkbox"/>
Responsiveness:	<input type="checkbox"/>	<input type="checkbox"/>	<input type="checkbox"/>	<input type="checkbox"/>	<input checked="" type="checkbox"/>
Cost Effectiveness:	<input type="checkbox"/>	<input type="checkbox"/>	<input type="checkbox"/>	<input checked="" type="checkbox"/>	<input type="checkbox"/>
Dependability:	<input type="checkbox"/>	<input type="checkbox"/>	<input type="checkbox"/>	<input type="checkbox"/>	<input checked="" type="checkbox"/>
Total Performance:	<input type="checkbox"/>	<input type="checkbox"/>	<input type="checkbox"/>	<input checked="" type="checkbox"/>	<input type="checkbox"/>
Overall Rating:	<input type="checkbox"/>	<input type="checkbox"/>	<input type="checkbox"/>	<input checked="" type="checkbox"/>	<input type="checkbox"/>

DEFECTS (IF ANY): IF CHECKED, PLEASE EXPLAIN:

Performance / Other Comments:

The City has used Ace Saginaw Asphalt for supplying asphalt products for several years and they have proved to be a dependable vendor.

REVIEWER'S SIGNATURE:

Dan Schiller

Dan Schiller (Jun 5, 2026 12:54:20 EDT)

Date:



SEALED PROPOSALS RECEIVED IN THE DIVISION OF PURCHASES & SUPPLIES

Asphalt Paving Materials

BID # 26000011

Approximate Annual Quantities – Not Guaranteed

Furnish as requested for the period 07/1/26 – 6/30/27

Item	Description	Quantity	Ajax Paving Materials	Extended Total	Ace Paving Company	Extended Total
1	1100T, 20AA - New	2,000 tons	\$70.50 /ton	\$141,000.00	\$77.00 /ton	\$154,000.00
2	SS-1h Tack Coat - new	200 gal	\$8.00 /gal	\$1,600.00	\$7.25 /gal	\$1,450.00
3	Cold milling asphalt	2,000 tons	\$6.50 /ton	\$13,000.00	\$11.50 /ton	\$23,000.00
4	Credit for stripped material returned for recycling	(as applicable)				N/A
5	QPR 2000 Cold patch	(not specified)			\$142.00 /ton	N/A
6	Permanent High Performance Cold patch (with guarantee)		\$140.00 /ton		N/A	N/A
7	High stability top	2,000 tons	\$79.25 /ton		\$81.50 /ton	\$163,000

Equipment Rental Rates (Hourly or Daily)		
Equipment	Ajax	Ace Paving Co
Large 8–12 ton roller	No Bid	\$265.00
46.5 ton Flowboy with operator	No Bid	\$215.00
Paver with operator	No Bid	\$400.00
Dump in with operator	No Bid	\$205
Equipment move(s) per each move	No Bid	\$500.00

A SPECIAL NOTE FROM THE PURCHASING DIVISION

Bid results posted are before evaluation team review and award recommendation.



Business Search

As of 6/5/2026:

Business Filings are processed through 06/03/2026.

Renewals and Restorations (for entities returning to good standing) are processed through 06/03/2026.

To file a document or annual report/statement for an existing entity, search for the entity, select Request Access from the slide-out drawer, complete the questions, refresh the webpage, and select File Subsequent Document or File Annual Report/Statement.

The same process applies to order certificates and copies.

You must be logged in to file documents or order certificates and copies. Click on the Login button in the top right. If you do not have an account, create one. The credentials from the previous system did not transfer to this system.

Business Search Info:

edw.c.levy co.

Advanced

Results: 1

Name	Filing Date	Status	AR Standing	Entity Type	Entity ID#	Agent	AR Due Date
edw.c.levy co.	07/03/1946	Active	Good	Domestic Profit Corporation	800173555	JUDITH A JERZEWSKI	05/15/2027



Department of Finance - Treasury

Sheldon Neeley
Mayor

Clyde Edwards
City Administrator

Good Standing Certification

Applicant and/or Business Clearance

All applicants for City of Flint funded programs, including federal programs, must remain current and not in default on any obligations related to taxes, fines, penalties, water service, licenses or other forms of penalties.

APPLICANT NAME: Ace Saginaw Paving

HOME ADDRESS: _____

DBA: _____

BUSINESS ADDRESS: 2981 Carrollton Rd., Saginaw, MI 48604

Please include addresses of all properties in the name of other current and/or former businesses, parent company, subsidiaries and/or divisions. Also, please include all former names used while conducting business with the City.

This section to be completed by the Department of Finance - Customer Service Division

Please check the following divisions for the status of current and delinquent obligations owed to the City of Flint. Please circle the appropriate response for each division.

WATER DIV.	CURRENT	DELINQUENT	No water in name
PROPERTY TAXES DIV.	<u>CURRENT</u>	DELINQUENT	
INCOME TAX DIV.	CURRENT	DELINQUENT	} Has never filed.
ENFORCEMENT	CURRENT	DELINQUENT	
MR	<u>CURRENT</u>	DELINQUENT	

If delinquencies exist, please indicate the date, type and amount of obligation:

Kathryn Neumann /2625
City Staff Person and Date

Clyde Edwards 2/3/26
City of Flint Customer Serv. Representative and Date



EDW. C. LEVY CO.

Unique Entity ID C6XYMH77UWJ5	CAGE / NCAGE 4D0Z4	Purpose of Registration All Awards
Registration Status Active Registration	Expiration Date Apr 2, 2027	
Physical Address 9300 Dix AVE Dearborn, Michigan 48120-1528 United States	Mailing Address 9300 Dix AVE Dearborn, Michigan 48120-1528 United States	

Business Information

Doing Business as (blank)	Division Name (blank)	Division Number (blank)
Congressional District Michigan 12	State / Country of Incorporation Michigan / United States	URL (blank)

Registration Dates

Activation Date Apr 6, 2026	Submission Date Apr 2, 2026	Initial Registration Date Apr 5, 2006
---------------------------------------	---------------------------------------	---

Entity Dates

Entity Start Date Jan 1, 1916	Fiscal Year End Close Date Dec 31
---	---

Immediate Owner

CAGE (blank)	Legal Business Name (blank)
------------------------	---------------------------------------

Highest Level Owner

CAGE (blank)	Legal Business Name (blank)
------------------------	---------------------------------------

Executive Compensation

Registrants in the System for Award Management (SAM) respond to the Executive Compensation questions in accordance with Section 6202 of P.L. 110-252, amending the Federal Funding Accountability and Transparency Act (P.L. 109-282). This information is not displayed in SAM. It is sent to USApending.gov for display in association with an eligible award. Maintaining an active registration in SAM demonstrates the registrant responded to the questions.

Proceedings Questions

Registrants in the System for Award Management (SAM.gov) respond to proceedings questions in accordance with FAR 52.209-7, FAR 52.209-9, or 2. C.F.R. 200 Appendix XII. Their responses are displayed in the responsibility/qualification section of SAM.gov. Maintaining an active registration in SAM.gov demonstrates the registrant responded to the proceedings questions.

Exclusion Summary

Active Exclusions Records?

No

SAM Search Authorization

I authorize my entity's non-sensitive information to be displayed in SAM public search results.

Yes

Entity Types

Business Types		
Entity Structure Corporate Entity (Not Tax Exempt)	Entity Type Business or Organization	Organization Factors Manufacturer of Goods
Profit Structure For Profit Organization		

260225



RESOLUTION NO.: _____

PRESENTED: 6-17-2026

ADOPTED: _____

BY THE CITY ADMINISTRATOR:

RESOLUTION AUTHORIZING LIGHTHOUSE INSURANCE GROUP TO PROVIDE THE CITY OF FLINT WITH PROPERTY AND LIABILITY COVERAGES FOR THE PERIOD 7/1/26-7/1/27

WHEREAS, Lighthouse Insurance Group, the City’s insurance broker, solicited proposals for Property, Inland-Marine Equipment Breakdown, Hi-Value Vehicles/Equipment, Auto Liability, Ambulance Liability, Excess Worker’s Compensation, and Terrorism insurance coverages.

Lighthouse Group recommends acquiring coverage through the following carriers for the period 7/1/26-7/1/27:

Carrier	Coverage Type	Premium
Arch Specialty Ins. Co.	Property	\$ 317,687.50
Lexington Ins. Co.	Property	\$ 361,250.00
Hiscox Ins. Co.	Property Terrorism	\$ 14,140.00
Hartford Steam Boiler	Equipment Breakdown	\$ 24,771.00
Travelers	Inland Marine	\$ 22,272.00
Mitsui & MSIG	Hi-Value Vehicle/Equip.	\$ 218,786.55
National Indemnity	Auto Liability	\$1,329,109.00
Hudson Ins. Co.	Ambulance Auto Liability	\$ 125,093.00
TDC Specialty Ins. Co.	Ambulance Professional Liability	\$ 31,080.88
Midwest Employer’s Casualty Co.	Excess Workers Compensation (year 1)	\$ 125,000.00
3.9% estimated contingency for additional premium owed for FY27		\$ 100,000.00
Total		\$2,669,189.93

GL/Account #	Account Name	Amount Requested
677-267.651-955.000	Risk and Benefit – Insurance	\$2,669,189.93

IT IS RESOLVED, that the appropriate City officials are authorized to enter into a contract with Lighthouse Insurance Group to provide the City with property and liability coverage for the period 7/1/26 through 7/1/27 at a combined premium cost amount not to exceed \$2,669,189.93. Funding for these services will come from Insurance Fund.

APPROVED AS TO FORM:

APPROVED AS TO FINANCE:

JoAnne Gurley
JoAnne Gurley, City Attorney

Phillip Moore
Phillip Moore, Chief Financial Officer

Clyde Edwards
Clyde Edwards, City Administrator

City Council



STAFF REVIEW FORM

Effective: April 1, 2026

(Do not alter or modify this form without written permission from the City Administrator)

TODAY'S DATE: June 3, 2026

BID PROPOSAL #:

AGENDA ITEM TITLE: Lighthouse Insurance Group to Provide the City of Flint with Property and Liability Coverages for the Period 7/1/26-7/1/27

PREPARED BY: V. Foster for P. Moore

VENDOR NAME: Lighthouse Group

Section 1. BACKGROUND/SUMMARY OF PROPOSED ACTION..

Vendor Compliance (This vendor has been properly vetted and the responses are below) :

Federal gov't	(All documentation current, no violations)	<input checked="" type="checkbox"/> YES	<input type="checkbox"/> NO
State gov't	(All documentation current, no violations)	<input checked="" type="checkbox"/> YES	<input type="checkbox"/> NO
City of Flint	(All documentation current, no violations)	<input checked="" type="checkbox"/> YES	<input type="checkbox"/> NO

The requesting authority is validating that this vendor has been in full compliance with all past contract provisions and has not violated the terms of any contract with the City of Flint.

NOTE: Preparer MUST include a response to the conditions below:

- **Did we do an assessment of first consideration to internal City of Flint staff and resources (explain)?**
- **Why was this vendor chosen?**
- **What history does this vendor have with the City of Flint?**
- **What steps will be taken to do a post-performance of the vendor?**

The Department of Finance is seeking approval to renew the City's comprehensive property, casualty, automobile, workers' compensation excess, inland marine, equipment breakdown, terrorism, hi-value vehicle/equipment, and ambulance liability insurance program for the policy period July 1, 2026, through July 1, 2027. The insurance proposal was prepared through the City's insurance broker and includes coverage from multiple highly rated insurance carriers to provide protection for City-owned property, vehicles, equipment, operations, and public services. The proposed insurance program provides coverage for approximately \$250.9 million in insured property values, vehicles and equipment, municipal operations, emergency services, and workers' compensation exposures.

The City does not possess the capacity to self-insure the full range of property, liability, automobile, equipment breakdown, terrorism, and workers' compensation exposures associated with municipal operations. Procuring commercial insurance coverage is necessary to mitigate financial risk and protect public assets.

As the City's broker, Lighthouse solicited bids from 21 different carriers. The review and recommendations of the Lighthouse for each coverage type are outlined in the attached proposal. The proposed insurance program was developed through a competitive marketing process in which numerous insurance markets were approached to obtain the most favorable combination of coverage, limits, and pricing available. The recommended carriers provide specialized municipal insurance coverage and maintain strong financial strength ratings.



STAFF REVIEW FORM

Effective: April 1, 2026

(Do not alter or modify this form without written permission from the City Administrator)

Lighthouse is recommending the following carriers for requested coverages:

Carrier	Coverage Type	Premium
Arch Specialty Ins. Co.	Property	\$ 317,687.50
Lexington Ins. Co.	Property	\$ 361,250.00
Hiscox Ins. Co.	Property Terrorism	\$ 14,140.00
Hartford Steam Boiler	Equipment Breakdown	\$ 24,771.00
Travelers	Inland Marine	\$ 22,272.00
Mitsui & MSIG	Hi-Value Vehicle/Equip.	\$ 218,786.55
National Indemnity	Auto Liability	\$1,329,109.00
Hudson Ins. Co.	Ambulance Auto Liability	\$ 125,093.00
TDC Specialty Ins. Co.	Ambulance Professional Liability	\$ 31,080.88
Midwest Employer's Casualty Co.	Excess Workers Compensation (year 1)	\$ 125,000.00
3.9% estimated contingency for additional premium owed for FY27		\$ 100,000.00
Total		\$2,669,189.93

Midwest Employers Casualty Company extended a 2-year renewal option of \$250,000, which represents savings of \$91,214.

PROCUREMENT (MUST BE SPECIFIED)

Please specify how this vendor was identified: (Check one)

- Sole Source (Please attach sole source statement to requisition)
- Competitive Bid Process (Please attach bid tabulation/documents to requisition)
- Cooperative Contract (MIDeal, Sourcewell, GSA, or other municipality)
 - *Contract must be attached to your requisition and contract must appear on the vendor's quote for goods/services
- (3) Quotes (please attach all quotes to your requisition)

Section 2. PREVIOUS ALLOCATIONS (INCLUDE ALL ACCOUNTS USED FOR THIS PURPOSE)/ PROVIDE RESOLUTION OR CONTRACT INFORMATION THAT APPLIES..

Fiscal Year	Account	PO Number	FY PO Amount	FY Expensed	Resolution
FY22	Insurance	Multiple	\$1,324,544		
FY23	Insurance	Multiple	\$1,570,638		
FY24	Insurance	Multiple	\$1,941,304		
FY25	Insurance	Multiple	\$2,624,612		
FY26	Insurance	Multiple	\$2,570,997		



STAFF REVIEW FORM

Effective: April 1, 2026

(Do not alter or modify this form without written permission from the City Administrator)

It should be noted that substantial increases were due to additional protection for operations previously not included in the City's insurance coverages over the past few years, including Terrorism, Ambulance Auto Liability, Ambulance Professional Liability, Auto Liability, and Law Enforcement Liability.

Section 3. POSSIBLE BENEFIT TO THE CITY OF FLINT (RESIDENTS AND/OR CITY OPERATIONS) INCLUDE PARTNERSHIPS AND COLLABORATIONS..

The proposed insurance coverage provides comprehensive risk management protection for City operations, employees, residents, public infrastructure, municipal buildings, vehicles, emergency response services, and equipment. The insurance coverage protects the City against significant financial losses resulting from property damage, vehicle accidents, equipment failures, terrorism-related events, professional liability claims, and workers' compensation exposures. Coverage supports uninterrupted delivery of critical municipal services, including public safety, public works, utilities, emergency medical services, and general government operations. By maintaining appropriate insurance coverage, the City safeguards public assets, preserves financial stability, and ensures compliance with risk management best practices.

Section 4. FINANCIAL IMPLICATIONS..

IF ARPA related Expenditure:

Has this request been reviewed by E&Y Firm: YES NO IF NO, PLEASE EXPLAIN: N/A

NOTE: Accountant MUST include the following information:

- What is the total amount budgeted for this purpose?
- What percentage is being spent with this vendor?
- What is the justification for spending this amount of money with this vendor?
- What percentage is being spent out of each line item used in this request?
- List all the known budgeted funds from that line item.

The proposed insurance program is a necessary operational expenditure that protects City assets, infrastructure, employees, vehicles, and operations from potentially catastrophic financial losses. Maintaining adequate insurance coverage is a prudent risk management practice and supports the City's ability to continue providing essential services.

The requested insurance expenses are included in the FY2027 adopted budget of \$2,700,000.00. Some of the policies are subject to additional premium during/at the conclusion of the policy for changes that occur throughout the coverage term due to estimated payrolls and the purchase of new vehicles/equipment. For this reason, the Finance Department is requesting approval of an additional \$100,000 (approximately 3.9% contingency to cover any property or equipment added throughout the year, as well as the final wage calculation determination based on applicable wages subject to worker's compensation insurance premium at the end of the policy term.

BUDGETED EXPENDITURE? YES NO IF NO, PLEASE EXPLAIN:



STAFF REVIEW FORM

Effective: April 1, 2026

(Do not alter or modify this form without written permission from the City Administrator)

Dept.	Name of Account	Account Number	Grant CODE	Amount
Ins. Fund	Insurance	677-267.651-955.000	N/A	\$2,669,189.93
FY27 GRAND TOTAL				\$2,669,189.93

WHEN APPLICABLE, IF MORE THAN ONE (1) YEAR, PLEASE ESTIMATE TOTAL AMOUNT FOR EACH BUDGET YEAR: (This will depend on the term of the bid proposal)

BUDGET YEAR 1: _____
 BUDGET YEAR 2: _____
 BUDGET YEAR 3: _____

OTHER IMPLICATIONS (i.e., collective bargaining).. _____

PRE-ENCUMBERED? YES NO REQUISITION NO: _____

ACCOUNTING APPROVAL: Philly Moo Date: _____
Phillip Moore (Jun 3, 2026 21:41:24 EDT)

WILL YOUR DEPARTMENT NEED A CONTRACT? YES NO

Section 5. RESOLUTION DEFENSE TEAM..

(Place the names of those who can defend this resolution at City Council)

	NAME	PHONE NUMBER
1	Phillip Moore, CFO	Ext. 2301
2	JoAnne Gurley, City Attorney	

STAFF RECOMMENDATION: (PLEASE SELECT): APPROVED NOT APPROVED

DEPARTMENT HEAD SIGNATURE: Philly Moo
Phillip Moore (Jun 3, 2026 21:41:24 EDT)
Phillip Moore, Chief Financial Officer

ADMINISTRATION APPROVAL: [Signature]
Clyde Edwards / A0670 (Jun 5, 2026 11:53:48 EDT)
(\$20,000 or above spending authorizations)



STAFF REVIEW FORM

Effective: April 1, 2026

(Do not alter or modify this form without written permission from the City Administrator)

Section 6. VENDOR EVALUATION..

Business Title: Insurance Premiums	Lighthouse Group	Vendor ID:	6662
Review Period: 2024-2026		Department:	Finance
Project Name: Insurance		Project Type:	

Vendor Goals:

Lighthouse has previously and is expected to provide proactive risk management guidance, market the City's insurance program to qualified carriers, and secure competitive coverage terms and pricing. The broker should maintain regular communication with City staff, provide timely and accurate policy servicing, assist with claims advocacy, and ensure compliance with applicable insurance requirements. Additionally, the broker should deliver strategic renewal planning, coverage analysis, and ongoing education regarding emerging risks and insurance market conditions.

	1 = Poor	2 = Fair	3 = Sufficient	4 = Good	5 = Excellent
Job Knowledge:	<input type="checkbox"/>	<input type="checkbox"/>	<input type="checkbox"/>	<input type="checkbox"/>	<input checked="" type="checkbox"/>
Work Quality:	<input type="checkbox"/>	<input type="checkbox"/>	<input type="checkbox"/>	<input type="checkbox"/>	<input checked="" type="checkbox"/>
Timeliness:	<input type="checkbox"/>	<input type="checkbox"/>	<input type="checkbox"/>	<input type="checkbox"/>	<input checked="" type="checkbox"/>
Compliance with Contract:	<input type="checkbox"/>	<input type="checkbox"/>	<input type="checkbox"/>	<input type="checkbox"/>	<input checked="" type="checkbox"/>
Warranty (If Product):	<input type="checkbox"/>	<input type="checkbox"/>	<input type="checkbox"/>	<input type="checkbox"/>	<input type="checkbox"/>
Responsiveness:	<input type="checkbox"/>	<input type="checkbox"/>	<input type="checkbox"/>	<input type="checkbox"/>	<input checked="" type="checkbox"/>
Cost Effectiveness:	<input type="checkbox"/>	<input type="checkbox"/>	<input type="checkbox"/>	<input checked="" type="checkbox"/>	<input type="checkbox"/>
Dependability:	<input type="checkbox"/>	<input type="checkbox"/>	<input type="checkbox"/>	<input type="checkbox"/>	<input checked="" type="checkbox"/>
Total Performance:	<input type="checkbox"/>	<input type="checkbox"/>	<input type="checkbox"/>	<input type="checkbox"/>	<input checked="" type="checkbox"/>
Overall Rating:	<input type="checkbox"/>	<input type="checkbox"/>	<input type="checkbox"/>	<input checked="" type="checkbox"/>	<input type="checkbox"/>

DEFECTS (IF ANY): IF CHECKED, PLEASE EXPLAIN:



STAFF REVIEW FORM

Effective: April 1, 2026

(Do not alter or modify this form without written permission from the City Administrator)

Performance / Other Comments:

Lighthouse, as the City's insurance broker, and participating carriers have provided a comprehensive insurance program tailored to the City's operational needs. The renewal program maintains broad coverage for municipal property, vehicles, equipment, emergency services, liability exposures, and workers' compensation risks. The broker successfully marketed the program to multiple insurance carriers and secured competitive coverage options while maintaining essential protection for City operation. Lighthouse has been effective in assisting the City in the procurement of coverage, as well as assisting in claims processes, and has a solid understanding of operations and needs.

REVIEWER'S SIGNATURE:

Philly Moore
Phillip Moore (Jun 3, 2026 21:41:24 EDT)

Date: _____

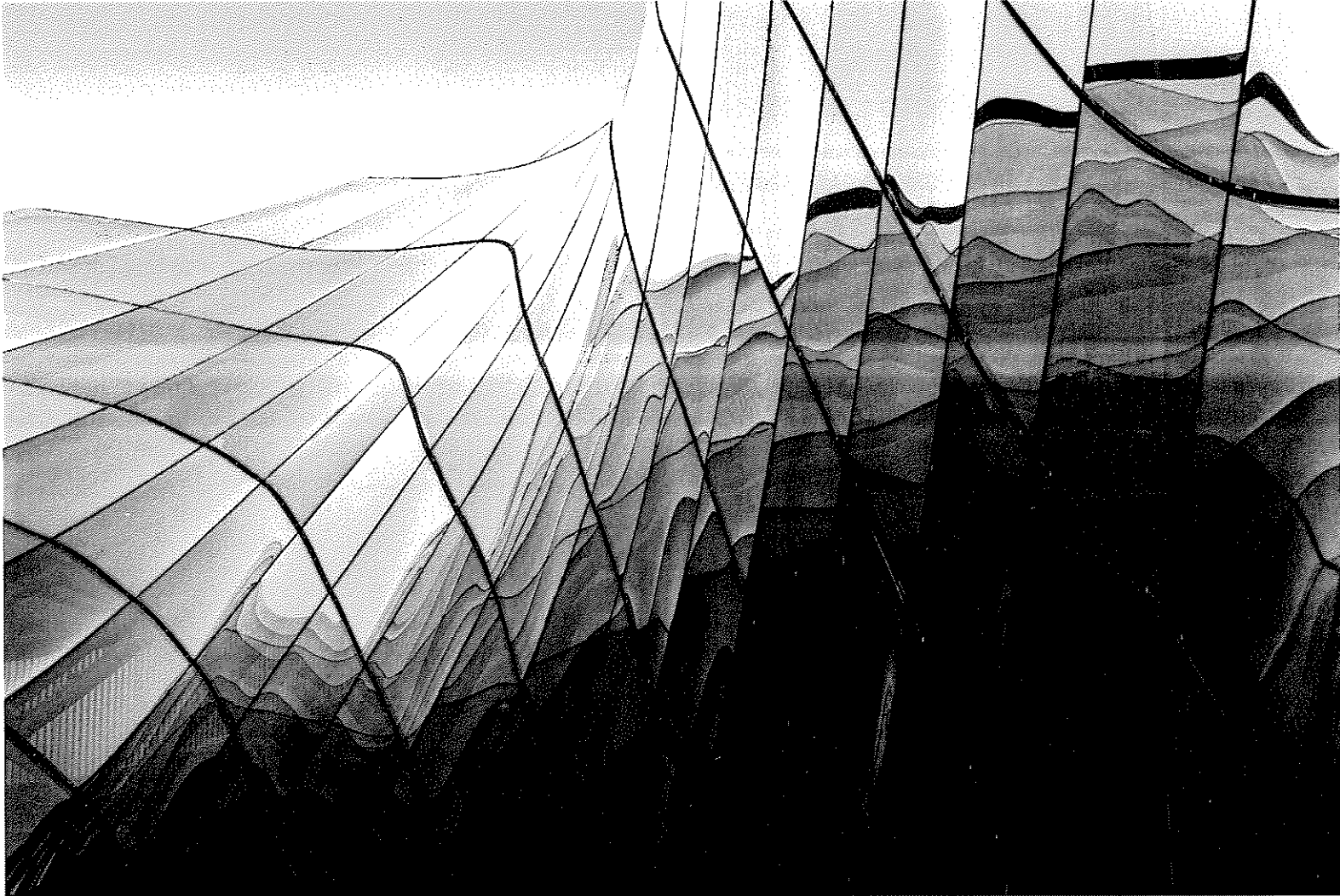

Insurance Proposal Prepared For

City of Flint

Effective 07-01-2026 to 07-01-2027



At a glance

When your business begins and ends with people, it's important to build lifelong client relationships rooted in trust and worth. We believe in delivering tailored solutions and comprehensive strategies to help businesses, individuals, families and communities achieve their goals.

Areas of expertise

Comprehensive solutions for employers and employees



EMPLOYEE BENEFITS

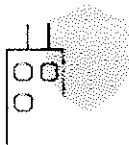

PROPERTY AND CASUALTY



RETIREMENT PLAN SERVICES

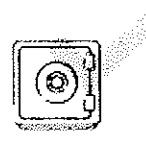

WEALTH SERVICES

How we work

COLLABORATIVELY

Collaboration is our North Star. We believe that collaboration helps us achieve client service excellence and ensures we grow with integrity, both as an organization and as individuals. Our collaborative culture exponentially increases our clients' access to expertise and new perspectives.

PURPOSEFULLY

Our clients benefit from our national resources and expertise with the purposeful advantage of local service. We elevate the client experience by providing a greater depth and breadth of resources, thinking innovatively and working together with both our clients and our colleagues to preserve strong community relationships.

SYNERGISTICALLY

We thrive and succeed when everyone contributes with their own backgrounds and competencies. Our differences make us stronger, and we're committed to keeping a diverse team to serve all of our clients' complex needs.

By the numbers

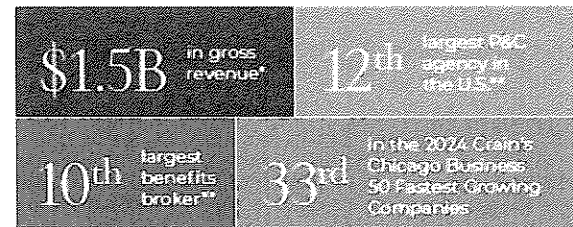

For more information, visit aleragroup.com

111 06/04/2025 09:11:00

* Statistics accurate as of 1/1/25
** January 2025 Business Insurance

Named Insureds

Coverage	City of Flint
Property	X
Property	X
Property Terrorism	X
Equipment Breakdown	X
Inland Marine	X
Inland Marine – High Value Vehicles	X
Auto Liability	X
Ambulance Auto Liability	X
Ambulance Professional Liability	X
Excess Workers Compensation	X
Aviation Liability	X

Location Schedule

Address	City	State	Zip
1101 S. Saginaw St	Flint	MI	48502
121 E. 7th St	Flint	MI	48502
210 E. Fifth St.	Flint	MI	48502
310 E. Fifth St	Flint	MI	48502
1525 M.L. King Ave	Flint	MI	48503
4309 Industrial	Flint	MI	
716 W. Pierson Rd.	Flint	MI	48502
202 E. Atherton	Flint	MI	48507
3310 E. Court St.	Flint	MI	48502
3318 E. Court St	Flint	MI	48502
4500 N. Dort Hwy	Flint	MI	48506
2800 Hammerburg Rd	Flint	MI	48507
1614 Dupont	Flint	MI	48504
G-4652 Beecher Rd.	Flint	MI	48507
251 E Blvd Drive	Flint	MI	48503
	Flint	MI	48503
1524 Mackin Rd.	Flint	MI	48503

This proposal is a summation of the limits, terms, coverages, and conditions all of which are superseded by the actual issued policy.

1416 Dupont Flint	Flint	MI	48503
2305 W. GL Ave	Flint	MI	48503
6625 Fleming Rd	Flint	MI	48504
5629 Fleming Rd	Flint	MI	48504
2420 Brownel	Flint	MI	48504
2300 Branch	Flint	MI	48506
1106 S. Averill St	Flint	MI	48506
930 E. Blvd. Drive	Flint	MI	48502
2401 Nolen Drive	Flint	MI	48503
1902 Hammerburg Rd	Flint	MI	48507
4266 E. Pierson Rd	Flint	MI	48506
3300-3400 N. Saginaw	Flint	MI	48502
2201 Forest Hill	Flint	MI	48504
1301-09 Pingree St	Flint	MI	48505
1002 W. Horne	Flint	MI	48504
249 Peer Ave	Flint	MI	48504
Vernon/Broadway	Flint	MI	48506
E. Fifth Ave/Root St	Flint	MI	48503
Brownell/W. Dayton	Flint	MI	48504
Woodland/E. Court St	Flint	MI	48532
M.L. King Ave/2 E Pierson	Flint	MI	48505
Averill/1-69 Expressway	Flint	MI	48506
Damon/N. Saginaw St.	Flint	MI	
E. Hamilton / Ave. A	Flint	MI	48505
640 W. Pasadena	Flint	MI	48505
1101 Kearsley Park Blvd	Flint	MI	48503
W. Court & Middleton	Flint	MI	48503
Tacken/Mann Hall	Flint	MI	48505
2 M.L. King Ave/N Saginaw	Flint	MI	48502
Lippincott & Clifford	Flint	MI	48503
Mason/Welch Blvd.	Flint	MI	48503
Miller Rd. / Court St	Flint	MI	48532
Saginaw St	Flint	MI	48502
Harrison St.	Flint	MI	48502
S.E. Saginaw St	Flint	MI	48502
Chicago Blvd / Clancy	Flint	MI	48502

This proposal is a summation of the limits, terms, coverages, and conditions all of which are superseded by the actual issued policy.

3201 Hammerburg Rd.	Flint	MI	48507
3821 N. Franklin	Flint	MI	48506
1701 Utah	Flint	MI	48506
1301-09 Pingree St	Flint	MI	48505
Pengelly/Milton Dr	Flint	MI	48504
Brookside/Woodlawn	Flint	MI	48504
Morningside Dr	Flint	MI	48504
702 W. 12th St	Flint	MI	48503
1106 S. Averill St	Flint	MI	48506
4535 M.L. King Ave	Flint	MI	48503
G-12233 E. Potter Rd	Flint	MI	48507
3402 Western Rd	Flint	MI	48506
1100 S. Cedar St	Flint	MI	48502

Property

Arch Specialty Ins Co

Coverages

Coverage	Limits	Cause of Loss	Valuation
Building and Business Personal Property	*5,000,000	Special	RC
Earth Movement	5,000,000		
Flood	5,000,000		
Total Insured Value	250,978,936		

*50% being 5,000,000 part of 10,000,000 per occurrence and excess of deductibles

RC = Replacement Cost

Deductibles

Coverage	Deductible
All Perils (Except Noted) per Occurrence	100,000
Special Flood Hazard Areas	500,000
Covered Property Classified as Underground Containment Structures	1,000,000
Earth Movement per Occurrence	100,000
Flood per Occurrence	5,000,000

This proposal is a summation of the limits, terms, coverages, and conditions all of which are superseded by the actual issued policy.

Additional Coverages

Coverage	Limit
Earth Movement	5,000,000 per Occurrence 5,000,000 Aggregate
Flood	5,000,000 per Occurrence 5,000,000 Aggregate, including Special Hazard Flood Area
Accounts Receivable	1,000,000
Builder's Risk	100,000
Builder's Risk Soft Cost	10,000
Civil Authority	Not Covered
Contingent Time Element	Not Covered
Debris Removal	2,500,000 or 25% of the adjusted property damage loss, whichever is less
Electronic Data and Media	2,500,000
Errors and Omissions	2,500,000
Extended Period of Indemnity	Not Covered
Extra Expense	Not Covered
Fine Arts	10,000 per item subject to a maximum sublimit of 100,000 per occurrence
Fire Department Service Charges	250,000
Ingress/Egress	Not Covered
Leased or Rented Equipment	10,000 subject to a 25,000 annual aggregate
Leasehold Interest	500,000
Lost Key	10,000
Miscellaneous Unnamed Locations	1,000,000
Newly Acquired Buildings	1,000,000
Non-owned detached trailers	5,000
Outdoor Property	100,000 subject to 250 per item for outdoor shrubs, trees, and plants
Personal Effects and Property of Others	100,000
Pollutant Clean Up and Removal	100,000
Professional Fees	100,000 per occurrence and annual aggregate
Property in Transit	100,000
Property Off Premises	100,000
Reclaiming, Restoring, or Repairing Land Improvements	10,000
Reward Reimbursement	10,000
Royalties	Not Covered
Spoilage	100,000
Utility Services Physical Damage Excluding Transmission and Distribution Lines	100,000

This proposal is a summation of the limits, terms, coverages, and conditions all of which are superseded by the actual issued policy.

Valuable Papers and Records	250,000
Expediting Expenses	500,000 per Occurrence
Limited Coverage for Fungus, Wet Rot, Dry Rot and Bacteria	100,000
Ordinance or Law Coverage A	Included
Ordinance or Law Coverage B	2,500,000 per Occurrence
Ordinance or Law Coverage C	2,500,000 per Occurrence

Property

Lexington Ins Co

Coverages

Coverage	Limits	Cause of Loss	Valuation
Building and Business Personal Property	*5,000,000	Special	RC
Earth Movement	5,000,000		
Flood	5,000,000		
Total Insured Value	250,978,936		

*50% being 5,000,000 part of 10,000,000 per occurrence in the primary
RC = Replacement Cost

Deductibles

Coverage	Deductible
All Perils (Except Noted) per Occurrence	100,000
Special Flood Hazard Areas	500,000
Covered Property Classified as Underground Containment Structures	1,000,000

Statement of Values

All values submitted are correct to the best of my knowledge and belief.

Signature and Title: _____

Date: _____

This proposal is a summation of the limits, terms, coverages, and conditions all of which are superseded by the actual issued policy.

Property Terrorism

Hiscox Ins Co

Coverages

Coverage	Limits
Terrorism and Sabotage	100,000,000 per Occurrence 100,000,000 Aggregate
Total Insured Value	250,978,936
Deductible	25,000
Waiting Period	0 Hours

Additional Coverages

Coverage	Limit
Business Interruption Sublimit	0
Civil or Military Authority Sublimit	Included
Debris Removal Expenses Sublimit	250,000
Decontamination Costs Excluding NCBR Sublimit	250,000
Demolition and Increased Cost of Construction Sublimit	1,000,000
Errors and Omissions Sublimit	250,000
Electronic Data Processing Media Sublimit	1,000,000
Extended Period of Indemnity Sublimit	0 and 180 Day(s)
Fine Art Sublimit	250,000
Ingress/Egress Sublimit	1,000,000, 30 Day(s), and 1 Mile(s)
Preservation of Property Sublimit	250,000
Professional Fees Sublimit	250,000
Relocation Expense Sublimit	250,000
Service Interruption Sublimit	1,000,000, 30 Day(s), and 1 Mile(s)
Transit Sublimit	250,000
Valuable Papers Sublimit	250,000
Accounts Receivable Sublimit	250,000
Asbestos Sublimit	Asbestos Sublimit \$ 500,000
Automatic Coverage Sublimit	1,000,000 and 30 Day(s)
Commissions, Profits, and Royalties Sublimit	\$ 250,000
Contingent Business Interruption – Named Suppliers/Customers Sublimit	0
Contingent Business Interruption – Unnamed Suppliers/Customers Sublimit	0
Delay in Startup Costs Sublimit	250,000

This proposal is a summation of the limits, terms, coverages, and conditions all of which are superseded by the actual issued policy.

Fire Protective Systems Sublimit	10,000
Green Building Additional Expense Sublimit	250,000
Key and Lock Expense Sublimit	250,000
Landscaping Sublimit	10,000
Leasehold Interest Sublimit \$ 0	0
Loss of Attraction Sublimit	0, 0 Day(s), and 0 Mile(s)
Miscellaneous Unnamed Locations Sublimit	1,000,000 and 30 Day(s)
Newly Acquired Locations Sublimit	1,000,000 and 90 Day(s)
Property In Course of Construction Sublimit	1,000,000
Rental Income Sublimit	0
Soft Costs Sublimit	250,000
Deductible	25,000
Waiting Period	0 Hours

This proposal is a summation of the limits, terms, coverages, and conditions all of which are superseded by the actual issued policy.

Location Schedule - Equipment Breakdown

Loc #	Address	City	State	Zip
001	1101 S. Saginaw St. Room 203	Flint	MI	48502
002	210 E Fifth St.	Flint	MI	48502
004	3420 St John St	Flint	MI	48502
011	4535 M L King Ave	Flint	MI	48503
012	310 E Fifth St	Flint	MI	48502
014	4309 Industrial	Flint	MI	48505
018	202 E Atherton	Flint	MI	48507
020	3310 East Ct St	Flint	MI	48502
022	4500 N Dort Hwy	Flint	MI	48506
023	2800 Hammerburg Rd	Flint	MI	48507
024	1614 Dupont	Flint	MI	48504
025	G-12233 E Potter Rd	Flint	MI	48507
030	G-4652 Beecher Rd	Flint	MI	48507
031	Avon St	Flint	MI	48503
034	6625 Fleming Rd	Flint	MI	48504
035	5629 Fleming Rd	Flint	MI	48504
036	2420 Brownel	Flint	MI	48504
038	2300 Branch	Flint	MI	48506
041	1106 S Averill St	Flint	MI	48506
042	930 East Blvd Dr.	Flint	MI	48502
044	4266 E Pierson Rd	Flint	MI	48506
046	2401 Nolen Dr.	Flint	MI	48503
047	1221 S Vernon	Flint	MI	48506
048	1902 Hammerburg Rd	Flint	MI	48507
049	3300-3400 N Saginaw	Flint	MI	48502
050	2201 Forest Hill	Flint	MI	48504
051	1301-09 Pingree St	Flint	MI	48505
052	1002 W Horne	Flint	MI	48504
053	249 Peer Ave	Flint	MI	48504
055	M L King Ave/2 E Pierson	Flint	MI	48505
057	Damon/N Saginaw St	Flint	MI	48501
058	E Hamilton/Ave A	Flint	MI	48505
061	1101 Kearsley Park Blvd	Flint	MI	48503

This proposal is a summation of the limits, terms, coverages, and conditions all of which are superseded by the actual issued policy.

065	Harrison St	Flint	MI	48502
066	Chicago Blvd / Clancy	Flint	MI	48502
069	3201 Hammerburg Rd	Flint	MI	48507
070	3821 N Franklin	Flint	MI	48506
072	Morningside Dr	Flint	MI	48504
073	702 W 12th St	Flint	MI	48503
077	251 East Blvd Dr	Flint	MI	48503
092	1525 M L King Ave	Flint	MI	48502
093	716 W Pierson Rd	Flint	MI	48502
098	630 S Saginaw St	Flint	MI	48507
099	4000 S Saginaw St	Flint	MI	48507
100	121 E 7th St	Flint	MI	48502
104	3402 Western Rd	Flint	MI	48506
105	1100 S Cedar St	Flint	MI	48502
109	G-4662 Beecher Rd	Flint	MI	48507
110	1524 Mackin Rd & 1416 Dupont	Flint	MI	48503
111	2305 W GL Ave	Flint	MI	48503
112	Averill/I-69 Expy	Flint	MI	48506
113	3310 East Ct St	Flint	MI	48506

This proposal is a summation of the limits, terms, coverages, and conditions all of which are superseded by the actual issued policy.

Equipment Breakdown

Locations – Coverage Part 1

Address	City	State
All Locations other than 022 and 030	Flint	MI

Subject of Insurance – Coverage Part 1

Coverage	Limit
Equipment Breakdown	50,000,000
Property Damage	Included
Business Income	Excluded
Extra Expense	1,000,000
Civil Authority	Included
Contingent Business Income	Excluded
Data Restoration	1,000,000
Demolition	1,000,000
Expediting Expenses	1,000,000
Green	25,000
Hazardous Substances	1,000,000
Mold	25,000
Newly Acquired Locations	1,000,000
Off Premises Equipment Breakdown	25,000
Ordinance or Law	1,000,000
Perishable Goods	1,000,000
Public Relations	Excluded
Service Interruption	1,000,000

Deductibles and Other Conditions – Coverage Part 1

Coverage	Limit/Deductible
Combined Policy Deductible	5,000
Newly Acquired Location Days	365
Service Interruption Deductible Hours	24 Hours

**“Covered Equipment” does not include “production machinery”

**Covered Services as defined under “interruption of service” includes “cloud computing service”

This proposal is a summation of the limits, terms, coverages, and conditions all of which are superseded by the actual issued policy.

Locations – Coverage Part 2

Address	City	State
4500 N Dort Hwy	Flint	MI
G-4652 Beecher Rd	Flint	MI

Covered Cause of Loss

Accident	Included
Electronic Circuitry Impairment	Included

Subject of Insurance – Coverage Part 2

Coverage	Limit
Equipment Breakdown	50,000,000
Property Damage	Included
Business Income	Excluded
Extra Expense	1,000,000
Civil Authority	Included
Contingent Business Income	Excluded
Data Restoration	1,000,000
Demolition	1,000,000
Expediting Expenses	1,000,000
Green	25,000
Hazardous Substances	1,000,000
Mold	25,000
Newly Acquired Locations	1,000,000
Off Premises Equipment Breakdown	25,000
Ordinance or Law	1,000,000
Perishable Goods	1,000,000
Public Relations	Excluded
Service Interruption	1,000,000

This proposal is a summation of the limits, terms, coverages, and conditions all of which are superseded by the actual issued policy.

Deductibles and Other Conditions – Coverage Part 2

Coverage	Limit/Deductible
Combined Policy Deductible	10,000
Newly Acquired Location Days	365
Service Interruption Deductible Hours	24 Hours

**“Covered Equipment” does not include “production machinery”

**Covered Services as defined under “interruption of service” includes “cloud computing service”

Data Compromise and Identity Recovery

Data Compromise

Coverage	Limit	Deductible
Response Expenses	50,000 Annual Aggregate	1,000 each
Legal and Forensic Information Technology Review	5,000 any one “Personal Data Compromise”	
Defense and Liability	50,000 Annual Aggregate	1,000 each

Identity Recovery

Coverage	Limit	Deductible
Expense Reimbursement	15,000 Annual Aggregate per “Identity Recovery Insured”	250 each
Lost Wages and Child and Elder Care	5,000	
Miscellaneous Unnamed Costs	1,000	

This proposal is a summation of the limits, terms, coverages, and conditions all of which are superseded by the actual issued policy.

Commercial Inland Marine

Miscellaneous Property

Coverage	Limit	Deductible
Scheduled Equipment	35,849	2,500

Coverage Extensions

Coverage	Limit
Fire Protection Systems	75,000
Newly Acquired Property	25,000
Preservation of Property Expense	5,000
Valuable Papers and Records	50,000
Additional Coverages	
Claim Data Expense	5,000
Debris Removal Increased Limit	75,000
Fire or Police Department Service Charge	25,000
Pollutant Clean Up and Removal	25,000
Reward Coverage	2,500

Computerized Business Equipment

Loc #	Coverage	Limit	Deductible
BLNKT	Hardware	2,205,192	5,000
BLNKT	Software	129,500	5,000
BLNKT	Business Income	409,500	5,000
BLNKT	Flood	2,744,192 Blanket Flood Limit 2,744,192 Blanket Flood Aggregate	25,000
BLNKT	Covered Property In Transit	100,000	5,000
BLNKT	Covered Property Temporarily Away from Scheduled Location	100,000	5,000

This proposal is a summation of the limits, terms, coverages, and conditions all of which are superseded by the actual issued policy.

Coverage Extensions

Coverage	Limit
Duplicate Software	100,000
Expediting Expenses	100,000
Fire Protection Systems	75,000
Incompatibility With Replacement Property	100,000
Newly Acquired Property	100,000
Preservation of Property Expense	5,000
Property At Newly Acquired Locations	100,000
Valuable Papers and Records	50,000
Additional Coverages	
Charges on Stolen Cellular Devices	5,000
Claim Data Expense	5,000
Debris Removal Increased Limit	75,000
Equipment Control Systems	25,000
Fire or Police Department Service Charge	25,000
Lost Warranty or Service Contract	5,000
Pollutant Clean Up and Removal	25,000
Reward Coverage	2,500

Contractors Equipment

Coverage	Limit	Deductible	Coinsurance
Scheduled Equipment	3,331,817	5,000** 10,000 Flood	80%
Unscheduled Equipment Owned by Others	200,000	5,000 10,000 Flood	
Equipment While Leased, Rented or Loaned To Others	250,000	5,000 10,000 Flood	

** 10,000 deductible at location 702 W. 12th Street, Flint MI

This proposal is a summation of the limits, terms, coverages, and conditions all of which are superseded by the actual issued policy.

Contractors Equipment Extensions

Coverage	Limit
Business Personal Property in Job Trailers	10,000
Document and Data Restoration Costs	50,000
Fire Protective Systems	75,000
Hauling Property of Others	100,000
Newly Acquired Equipment – Per Item	250,000
Rental Costs:	
• Any One Item	5,000
• Any One Occurrence	100,000
Upgrades to Covered Property	25,000
Additional Coverages	
Claim Data Expenses	5,000
Continuing Rental Payments:	
• Any One Item	5,000
• Any One Occurrence	25,000
Contract Penalty	25,000
Debris Removal Increased Limit	75,000
Employee Tools, Equipment and Clothing	
• Any One Item	1,000
• Any One Employee	2,500
• Any One Occurrence	5,000
Errors or Unintentional Omissions	100,000
Expediting Expenses	25,000
Expendable Supplies	10,000
Fire Or Police Department Service Charge	25,000
Lost Warranty or Service Contract	10,000
Pollutant Clean Up And Removal	25,000
Preservation of Property Expense	50,000
Reward Coverage	2,500
Tracking System Deductible Waiver Amount	10,000

This proposal is a summation of the limits, terms, coverages, and conditions all of which are superseded by the actual issued policy.

Communications Coverages

Coverage	Limit	Deductible
Scheduled Towers	120,000	5,000

Locations

Address	Coverage	Limit
310 E 5th St, Flint MI	Tower/Antenna	60,000
G-4652 Beecher Rd, Flint MI	Tower	30,000
702 W 12th St, Flint MI	Tower	30,000

Communications Coverage Extensions

Coverage	Limit
Expediting Expenses	25,000
Fine Art	50,000
Fire Protection Systems	75,000
Newly Acquired or Constructed Property	250,000
Personal Effects	2,500
Tower Collapse Damage to Buildings that are Not Covered Property	25,000
Tuning of Towers	50,000
Valuable Papers and Records	50,000
Additional Coverages	
Claim Data Expense	5,000
Debris Removal Increased Limit	25,000
Fire or Police Department Service Charge	25,000
Ordinance or Law	100,000
Pollutant Clean Up and Removal	15,000
Preservation of Property Expense	25,000
Reward Coverage	25% of covered loss up to 2,500

Additional Coverages

Coverage	Limit
Flood Limitation – Described Property or Locations	3,531,817
Earth Movement Limitation – Described Property or Locations	3,531,817
Electronic Vandalism	10,000
Fungus, Wet Rot and Dry Rot	10,000

This proposal is a summation of the limits, terms, coverages, and conditions all of which are superseded by the actual issued policy.

Commercial Inland Marine

High Valued Vehicles

Contractors Equipment

Coverage	Limit
Property Covered	Per Schedule on File
Policy Limit	5,000,000
Catastrophe Limit	5,000,000
Additional Debris Removal Expenses	25,000
Equipment Leased or Rented to Others	Not Covered
Fraud and Deceit	50,000
Waterborne Contractors' Equipment	50,000
Claim Preparation Expense	10,000
Continuing Rental or Lease Payments	10,000
Construction Trailers	
• Any One Construction Trailer	10,000
• All Construction Trailers	50,000
Equipment Leased or Rented From Others	Not Covered
Expediting Expenses	25,000
Fire Department Service Charges	1,000
Pollutant Cleanup and Removal	25,000
Recharge of Fire Extinguishing Equipment	1,000
Rental Reimbursement	
• Reimbursement Limit	25,000
• Waiting Period	72 Hours
Rewards	1,000
Spare Parts and Fuel	10,000
Employee Tools	
• Any One Employee Tools	2,500
• All Employee Tools	100,000
Your Tools	
• Any One Tool	2,500
• All Tools	100,000
Coinsurance	80%
Valuation	Actual Cash Value, Replacement Cost Value for equipment 5 years old or newer
Coinsurance	80%
Deductible	25,000 per Occurrence

This proposal is a summation of the limits, terms, coverages, and conditions all of which are superseded by the actual issued policy.

Auto Physical Damage Coverage

Covered Property	Limit
Policy Limit	1,500,000 per occurrence
Per Vehicle Limit	1,100,000
Catastrophe Limit	1,500,000
Earthquake Limit	1,500,000
Flood Limit	1,500,000
	Insurer shall pay claims for the lesser of:
	<ul style="list-style-type: none"> • Actual cash value at the time of the loss with any depreciation deduction • Cost to replace in part or in whole, property with like kind and quality • Limit "As per Declarations Page"
Valuation	
Deductible	25,000 per Occurrence
Total Insured Value	18,708,489

Auto Physical Damage Coverage Extensions and Supplemental Coverages

Coverage	Limit
Towing and Storage	25,000 Sublimit per Vehicle
Debris Removal Expense	10,000 Sublimit per Occurrence
Glass Breakage, Impact with Bird or Animal or Falling Objects	5,000 Sublimit per Vehicle
Temporary Replacement Vehicle	150,000 Sublimit per Vehicle
Temporary Transportation Rental Expenses	10,000 Sublimit per Vehicle
On-Board Electronic Equipment	10,000 Sublimit per Vehicle
Newly Acquired Vehicles	250,000 Sublimit per Vehicle
<ul style="list-style-type: none"> • Number of Days Newly Acquired Vehicle is Covered • Report Newly Acquired Vehicle(s) within: 	30 Days 30 Days of Acquisition
Pollutant Clean Up and Removal Expenses	25,000 Sublimit Policy Period Aggregate
Fire Brigade Charges and Extinguishing Expenses	5,000 Sublimit per Occurrence

This proposal is a summation of the limits, terms, coverages, and conditions all of which are superseded by the actual issued policy.

Automobile Liability - NICO

Coverages/Limits

Coverage Description	Limits
Combined Single Limits Liability	1,000,000
Personal Injury Protection	Unlimited
Property Protection Insurance	1,000,000
Mini-Tort	3,000
Hired and Non Owned Liability	1,000,000
Total Number of Vehicles: 461	
Total Number of Drivers: 476	

Covered Auto Symbols

Liability	7,8,9
Uninsured Motorists	7
Property Protection Insurance	7
Personal Injury Protection	7
Physical Damage	7

Covered Auto Symbols:

- 1-Any Auto
- 2-Owned Autos
- 3-Owned Private Passenger Autos
- 4-Owned Autos Other Than Private Passenger Autos
- 5-All Owned Autos Which Require No-Fault Coverage
- 6-Owned Autos Subject to Compulsory UM Laws
- 7-Autos Specified on Schedule
- 8-Hired Autos
- 9-Non-Owned Autos

This proposal is a summation of the limits, terms, coverages, and conditions all of which are superseded by the actual issued policy.

Ambulance Auto Liability

Coverages/Limits

Coverage Description	Limits	Deductible
Combined Single Limits Liability	1,000,000	
Personal Injury Protection	250,000	
Property Protection Insurance	Statutory	
Physical Damage – Collision	Stated Value	10,000
Physical Damage - Comprehensive	Stated Value	10,000
Towing and Storage	10,000	
Total Number of Vehicles	4	
Excluded Drivers	Kone Bowman Dean Shafer Dmorea Mays	

Covered Auto Symbols

Liability	7
Property Protection Insurance	5
Personal Injury Protection	5
Physical Damage – Collision	7
Physical Damage - Comprehensive	7

Vehicle Schedule

VIN	Liab	Physical Damage	Stated Value
1FDBR1CG6PKB89891	X	Included	190,257
1FDBW2CG8PKB90085	X	Included	182,417
1FDBW2CG6PKB90084	X	Included	182,417
1FDBW2CG2TKA05250	X	Included	225,000

This proposal is a summation of the limits, terms, coverages, and conditions all of which are superseded by the actual issued policy.

Ambulance Professional Liability

Coverage Form Used

Coverage	Occurrence/Claims Made	Retroactive Date
Professional Liability	Claims Made	10/01/2024
General Liability	Occurrence	NA

Professional Liability

Coverage	Limit/Deductible
Each Claim (Other than Physical Abuse and Sexual Misconduct Claims)	1,000,000
Physical Abuse/Sexual Misconduct Sublimit	100,000 Each Claim 300,000 Aggregate
Aggregate for All Claims	3,000,000
Deductible Each Claim	10,000

General Liability

Coverage	Limit/Deductible
Each Claim	1,000,000
Products Completed Operations Hazard	1,000,000
Damage to Rented Premises	NA
Medical Expenses	5,000
Aggregate for All Claims and Medical Expenses	3,000,000
Deductible Each Claim	10,000

Additional Coverages

Coverage	Limit
Evacuation Expense	
Each Evacuation	100,000
Aggregate	100,000
Legal/Media Expense	
Each Lega Defense Proceeding	100,000
Aggregate for All Legal Defense Proceedings	100,000

This proposal is a summation of the limits, terms, coverages, and conditions all of which are superseded by the actual issued policy.

Excess Workers Compensation

Workers Compensation State Information

State

MI

Excess Coverages

Coverage/Rating	Limit
Specific Retention	
Each Accident	1,000,000
Each Employee for Disease	1,000,000
Specific Limit Each Accident	
Policy Part One, Workers Compensation	Statutory
Policy Part Two, Employers Liability	1,000,000
Specific Limit Each Employee for Disease	
Policy Part One, Workers Compensation	Statutory
Policy Part Two, Employers Liability	1,000,000
Classification of Operations	
Experience Modification Factor	1.00

Rating Information

State	Class Code	Categories, Duties, Classifications	Exposure
MI	5509	Street or Road Maintenance	1,551,352
MI	6306	Sewer Op or Drivers	1,163,514
MI	6319	Gas Main or Connections	1,551,352
MI	7520	Waterworks	1,551,351
MI	7539	Meter Readers	If Any
MI	7580	Sewage Disposal Plant Oper	1,628,919
MI	7704	Firefighters & Drivers	6,205,400
MI	7720	Police Officers & Drivers	9,308,107
MI	8392	Garage Employees	581,757
MI	8810	Clerical Employees	11,673,916
MI	8820	Attorney	736,892
MI	9015	Janitorial/Maintenance	581,757
MI	9502	Street Cleaning	504,189
MI	9510	Municipal Employees NOC	1,745,270
		Total Payroll	38,783,774

This proposal is a summation of the limits, terms, coverages, and conditions all of which are superseded by the actual issued policy.

Premium Summary

City of Flint

Coverage	Carrier	Expiring Premium	Annualized Expiring	Renewal Premium	Premium Difference
Property (incl. surplus lines taxes & fees)	Arch Specialty Ins Co	\$540,289.82	\$351,666.25	\$317,687.50	(\$33,978.75)
Property (incl. surplus lines taxes & fees)	Lexington Ins Co	\$564,291.04	\$383,800	\$361,250	(\$22,550)
Property Terrorism	Hiscox Insurance Co	\$24,946.45	\$15,369	\$14,140	(\$1,229)
Equipment Breakdown (incl. taxes and surcharges)	Hartford Steam Boiler	\$25,372	\$25,372	\$24,771	(\$601)
Inland Marine	Travelers	\$22,272	\$22,272	\$22,272	\$0
Inland Marine High Valued Vehicles (incl. surplus lines taxes & fees)	Mitsui Sumitomo Ins USA Inc. & MSIG Specialty Ins USA Inc.	\$381,085.78	\$239,552.76	\$218,786.55	(\$20,766.21)
Business Auto (incl. fees)	National Indemnity Company (NICO)	\$1,332,713	\$1,332,713	\$1,329,109	(\$3,604)
Ambulance Auto Liability	Hudson Insurance Company	\$86,504	\$86,504	\$125,093	\$38,589
Ambulance Professional Liability (incl. surplus lines taxes, fees, & terrorism)	TDC Specialty Ins Co	31,080.88	31,080.88	\$31,080.88	\$0
Excess Workers Compensation (incl. flat charges, taxes, fees, & terrorism)	Midwest Employers Casualty Co	\$158,786	\$158,786 (1-Year)	\$250,000 (2-Year)	\$91,214
Total Program		\$3,167,340.97	\$2,647,115.89	\$2,694,189.93	\$47,074.04

All quoted premiums are annual estimates

Policy documents and endorsements will be delivered electronically unless otherwise requested

This proposal is a summation of the limits, terms, coverages, and conditions all of which are superseded by the actual issued policy.

Company	Best Rating	Admitted or Non Admitted
Arch Specialty Ins Co	A+ (Superior)	Non-Admitted
Lexington Ins Co	A (Excellent)	Non-Admitted
MSIG Specialty Ins USA Inc.	A+ (Superior)	Non-Admitted
TDC Specialty Ins Co	A (Excellent)	Non-Admitted

This proposal contains a surplus lines policy or policies (collectively, the “**Surplus Lines Policy**”) that is (1) underwritten by the insurance company identified therein (the “**Surplus Lines Insurer**”), which is not licensed by the insurance department of the State of Michigan (the “State”) and (2) issued pursuant to the surplus lines laws of the State. In the event the Surplus Lines Insurer becomes insolvent, the Surplus Lines Policy would not be protected by the State insurance guaranty fund, which provides a mechanism for the payment of covered claims under certain insurance policies to avoid excessive delay in payment and financial loss to claimants or policyholders because of the insolvency of a licensed and admitted insurance company.

Coverage Options

- Excess Workers Compensation
 - Midwest Employers Casualty
 - Excess Workers Compensation – 2 Year Option: \$250,000
 - AMWINS – Wesco Insurance Company
 - \$1,000,000 SIR Quote with no submission rate guarantee: \$108,595
 - AMWINS – The Gray Insurance Company
 - \$250,000 SIR Quote Excess of \$750,000 with rate guarantee: \$35,999
- Inland Marine – High Value Vehicles
 - Starr Surplus Lines Ins Co

Underwriting Notes

- NICO Driver Guidelines:
 - For drivers 25 years and older: No more than four moving violations or one accident and one violation within the last three years.
 - For drivers 23 or 24 years old: No more than two moving violations within the last three years.
 - No driver may have any major convictions within the last five year period.
 - For any vehicles requiring a Commercial Driver’s License: Drivers must have a minimum of one year with appropriate CDL and experience driving similar vehicles to those scheduled on this quote. For drivers with less than 1 year of experience, please submit to the underwriter for review.
- Inland Marine – High Value Vehicles Mitsui Benefits
 - Contractors’ equipment form is admitted - no Surplus Lines Taxes
 - The rates offered on the Contractor’s Equipment form, are significantly less than the composite rating offered by Starr.
 - The TIV has been split between the two lines:
 - Rate for the Contractors’ Equipment is now .30 (vs expiring \$1.29)
 - Rate for the APD is up from \$1.29 to \$1.40 (because its \$4.9M less in TIV).

Markets Approached

This proposal is a summation of the limits, terms, coverages, and conditions all of which are superseded by the actual issued policy.

- AIB
- AIG
- Allied World Assurance Company
- AmWins Global Risks Ltd
- ARCH Insurance Group
- ASCS
- Aspen Insurance
- AXIS Insurance
- Beazley USA
- Berkshire Hathaway Specialty Insurance Company
- Great American Insurance Company
- Intact Specialty Property
- Markel
- Mitsui Sumitomo Insurance
- Munich Re America
- Risksmith Insurance Services
- RSUI
- Sampo International
- Swiss Re
- Waypoint (AmRisc)
- Westchester, A Chubb Company

This insurance proposal is based upon your insurance history and the information that you have provided. It is your responsibility to review each item to make sure that you have all the coverages that you need, and that the limits of liability are appropriate.

Agreement and Acceptance

Effective Date: 07/01/2026

This Proposal is a brief overview of the insurance coverages that we propose meet the needs of your company. The Proposal is based on our best understanding of the information that you have provided to us, and it represents a general description of the program that we are recommending for your consideration. Please note that this Proposal does not encompass all the terms, conditions, limitations, and exclusions that will comprise the final insurance policies. The insurance policies issued to you by the carriers, rather than this proposal, will determine the applicable coverage on any loss.

We strongly encourage that you review the proposal carefully to ensure that we have appropriately captured your insurance needs. If not, please promptly make us aware of changes that you would like to see in the program, either by completing the information below or by contacting your Alera representative. Additional coverages and higher limits may be available at your request and for an additional cost.

Coverage is not bound without payment (which may include a completed finance agreement) and written confirmation of binding from our office.

Your signature below confirms that this Proposal has been reviewed with you by your Alera representative and that you accept the terms and conditions as offered or with the changes noted below, if any.

Policy Type	Description of Change

Policy documents and endorsements will be delivered electronically unless otherwise requested.

Named Insured

Signature and Title: _____

Date: _____

This insurance proposal is based upon your insurance history and the information that you have provided. It is your responsibility to review each item to make sure that you have all the coverages that you need, and that the limits of liability are appropriate.

This proposal is a summation of the limits, terms, coverages, and conditions all of which are superseded by the actual issued policy.



260226

RESOLUTION NO.: _____

PRESENTED: 6-17-2026

ADOPTED: _____

RESOLUTION APPROVING THE SALE OF CITY OWNED PROPERTY TO MICHIGAN DEPARTMENT OF TRANSPORTATION FOR ITS ROAD RECONSTRUCTION AND BRIDGE REPLACEMENT PROJECT ON I-475 FROM THE FLINT RIVER TO CARPENTER ROAD

BY THE CITY ADMINISTRATOR:

WHEREAS, pursuant to Section 18.20-21 of the Flint Purchasing Ordinance, the Flint City Council must approve the sale of city-owned property; and

WHEREAS, the Michigan Department of Transportation (“MDOT”) is performing “Road Reconstruction and Bridge Replacement, Bridge Removal, Deck Replacement, Overlay and Substructure Patching” on I-475 from the Flint River to Carpenter Road; and

WHEREAS, to complete the reconstruction project, MDOT has submitted a good faith offer (GFO) to purchase part of Parcel 41-19-131-021, an abandoned railroad by Atherton and S. Saginaw Street and a consent to grade as identified in the Legal Description attached in Exhibit A; and

WHEREAS, MDOT has offered Eleven Thousand Two-Hundred Dollars (\$11,200) for the parcel and a consent to grade based on a market study; and

WHEREAS, the Flint City Assessor has confirmed that the GFO is a fair market price for the parcel; and

WHEREAS, the sale of the reference property to MDOT shall be subject to all applicable guidelines, zoning changes, variances, permits and/or licenses and the City of Flint shall retain all easements; and

WHEREAS, City Administration recommends selling the parcel to MDOT and to consent to the grading for the offered purchase price of \$11,200.

THEREFORE, IT IS RESOLVED that the Flint City Council authorizes the sale of part of Parcel No. 41-19-131-021 as identified in the Legal Description-Attachment A, to the Michigan Department of Transportation for the good faith offer of \$11,200 subject to the City’s retainage of all easements.

FOR THE CITY:

FOR CITY CLERK:

Sheldon A. Neeley, Mayor

Davina Donahue, City Clerk

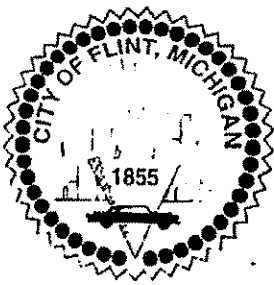

FOR THE CITY:

Clyde Edwards, City Administrator
A0674

FOR THE COUNCIL:

Candice Mushatt, Council President

APPROVED AS TO FORM:

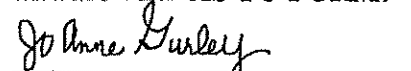
JoAnne Gurley, City Attorney

Legal Description: Fee Partial

**MDOT FEE ACQUISITION PARCEL DESCRIPTION
MDOT PARCEL 25132, CONTROL SECTION 7012**

PART OF THE SOUTHEAST 1/4 OF SECTION 19, TOWN 07 NORTH, RANGE 07 EAST, CITY OF FLINT, GENESEE COUNTY, MICHIGAN, DESCRIBED AS: COMMENCING AT THE SOUTH 1/4 CORNER OF SAID SECTION 19, THENCE NORTH 02°17'48" WEST, 2362.94 FEET ALONG THE NORTH-SOUTH 1/4 LINE OF SAID SECTION 19 TO THE SURVEY CENTERLINE OF THE CHESAPEAKE AND OHIO RAILWAY COMPANY'S MAIN TRACK PER QUIT CLAIM DEED RECORDED IN LIBER 1799, PAGE 633, GENESEE COUNTY RECORDS AND GRANT OF OVERHEAD EASEMENT RECORDED IN LIBER 1799, PAGE 634, GENESEE COUNTY RECORDS; THENCE SOUTH 46°30'32" EAST, 967.00 FEET ALONG SAID SURVEY CENTERLINE OF THE CHESAPEAKE AND OHIO RAILWAY COMPANY'S MAIN TRACK TO THE WESTERLY LIMITED ACCESS RIGHT OF WAY LINE OF I-475 AND THE POINT OF BEGINNING; THENCE NORTH 46°08'02" EAST, 49.55 FEET ALONG THE WESTERLY LIMITED ACCESS RIGHT OF WAY LINE OF I-475 TO A POINT ON THE NORTHERLY LINE OF PROPERTY FORMERLY OWNED BY THE CHESAPEAKE AND OHIO RAILWAY COMPANY; THENCE DEPARTING FROM THE WESTERLY LIMITED ACCESS RIGHT OF WAY LINE OF I-475, SOUTH 46°30'32" EAST, 329.69 FEET ALONG THE SAID NORTHERLY LINE OF PROPERTY FORMERLY OWNED BY THE CHESAPEAKE AND OHIO RAILWAY COMPANY TO THE EASTERLY LIMITED ACCESS RIGHT OF WAY LINE OF I-475; THENCE THE FOLLOWING TWO COURSES ALONG THE EASTERLY LIMITED ACCESS RIGHT OF WAY LINE OF I-475, (1) SOUTH 43°07'09" WEST, 49.50 FEET; AND (2) SOUTH 36°55'45" WEST, 212.45 FEET TO A POINT ON THE SOUTHERLY LINE OF PROPERTY FORMERLY OWNED BY THE CHESAPEAKE AND OHIO RAILWAY COMPANY; THENCE DEPARTING FROM THE EASTERLY LIMITED ACCESS RIGHT OF WAY LINE OF I-475, NORTH 39°13'20" WEST, 337.23 FEET ALONG SAID SOUTHERLY LINE OF PROPERTY FORMERLY OWNED BY THE CHESAPEAKE AND OHIO RAILWAY COMPANY TO THE WESTERLY LIMITED ACCESS RIGHT OF WAY LINE OF I-475; THENCE NORTH 36°01'10" EAST, 169.73 FEET ALONG THE WESTERLY LIMITED ACCESS RIGHT OF WAY LINE OF I-475 TO THE POINT OF BEGINNING. CONTAINING 79,125 SQUARE FEET (1.816 ACRES), MORE OR LESS.

CONTROL SECTION 25132	JOB NUMBER 210086	PARCEL 7012
OWNER OF RECORD CITY OF FLINT		
PROPERTY TAX CODE 41-19-131-021		

Addendum for Fee Acquisition

PRICE: The owner(s) will sell the property described in the attached legal description(s) to the Michigan Department of Transportation for the sum of \$10,900.00 via the appropriate instrument(s), clear of all encumbrances and subject only to easements and restrictions of record.

TITLE: The owner(s) shall not sell, convey, mortgage, or otherwise encumber the title to the property or any part thereof, or permit any act or deed to diminish the value of the property described in the attached legal description(s).

TAXES: The owner(s) shall pay all real estate taxes due and payable at the time of closing. The owner(s) shall pay any special assessment levied at the time of closing. The owner(s) shall pay any personal property taxes due and payable at the time of closing, including all jeopardy assessments filed at the time of closing. Ad-valorem real taxes will be prorated in accordance with The General Property Tax, Act 206 of 1893, as amended (MCL 211.2 *et seq.*).

IMPROVEMENTS: This sale includes all buildings, structures, trees, and other improvements located within the attached fee legal description(s).

OCCUPANCY: MDOT will become the owner of the property upon payment of the price listed above. The owner(s) shall have the right to occupy the improvements on the property for a period of 90 days after the closing. However, if the improvements on the property are vacated after the execution of this Acceptance of the Good Faith Offer, they cannot be reoccupied. Any personal property or fixtures that have not been removed by the date specified in a Notice to Quit issued by MDOT shall be deemed abandoned and will become the property of MDOT. This provision does not apply to hazardous material.

ESCROW AGENT: The owner(s) agree(s) that SARGENT'S TITLE COMPANY - FLINT (Commitment # 25-57575 UPD2) may act as escrow agent in closing this sale. All sums necessary to satisfy and discharge all liens, encumbrances and taxes, and to secure and record the instruments necessary to vest an unencumbered title in the name of the Michigan Department of Transportation, subject only to easements and restrictions of record, will be deducted from the proceeds.

DELAYED PAYMENT: The owner(s) agree(s) to a post-closing refund of prorated prepaid ad-valorem taxes when applicable.

MINERAL RIGHTS: Fluid mineral and gas rights are included.

SPECIAL PROVISIONS: NONE

CONTROL SECTION 25132	JOB NUMBER 210086	PARCEL 7012
OWNER OF RECORD CITY OF FLINT		
PROPERTY TAX CODE 41-19-131-021		

Addendum for Consent(s)

PRICE: The owner(s) agree(s) to grant the property described in the attached legal description(s) to the Michigan Department of Transportation for the sum of \$300.00 via the appropriate instrument(s).

CONSENT TYPE(S): Consent to Grade

OCCUPANCY: The owner(s) agree(s) to grant the Michigan Department of Transportation occupancy of the described property upon payment of the price listed above effective from start of project through completion of project.

CONVEYANCE: The owner(s) agree to deliver to MDOT the above cited consents subject to the following provision: This conveyance includes, but is not limited to, the right to any drainage structure replacement or repair; the right to remove trees, shrubs, and vegetation as necessary in the judgement of the Michigan Department of Transportation and the right of temporary occupancy by public utilities.

SPECIAL PROVISIONS: NONE

CONTROL SECTION 25132	JOB NUMBER 210086	PARCEL 7012
OWNER OF RECORD CITY OF FLINT		
PROPERTY TAX CODE 41-19-131-021		

Legal Description: Consent to Grade
Station # 285 +53.58 RT - 285+83.17 RT
 See attached sketch

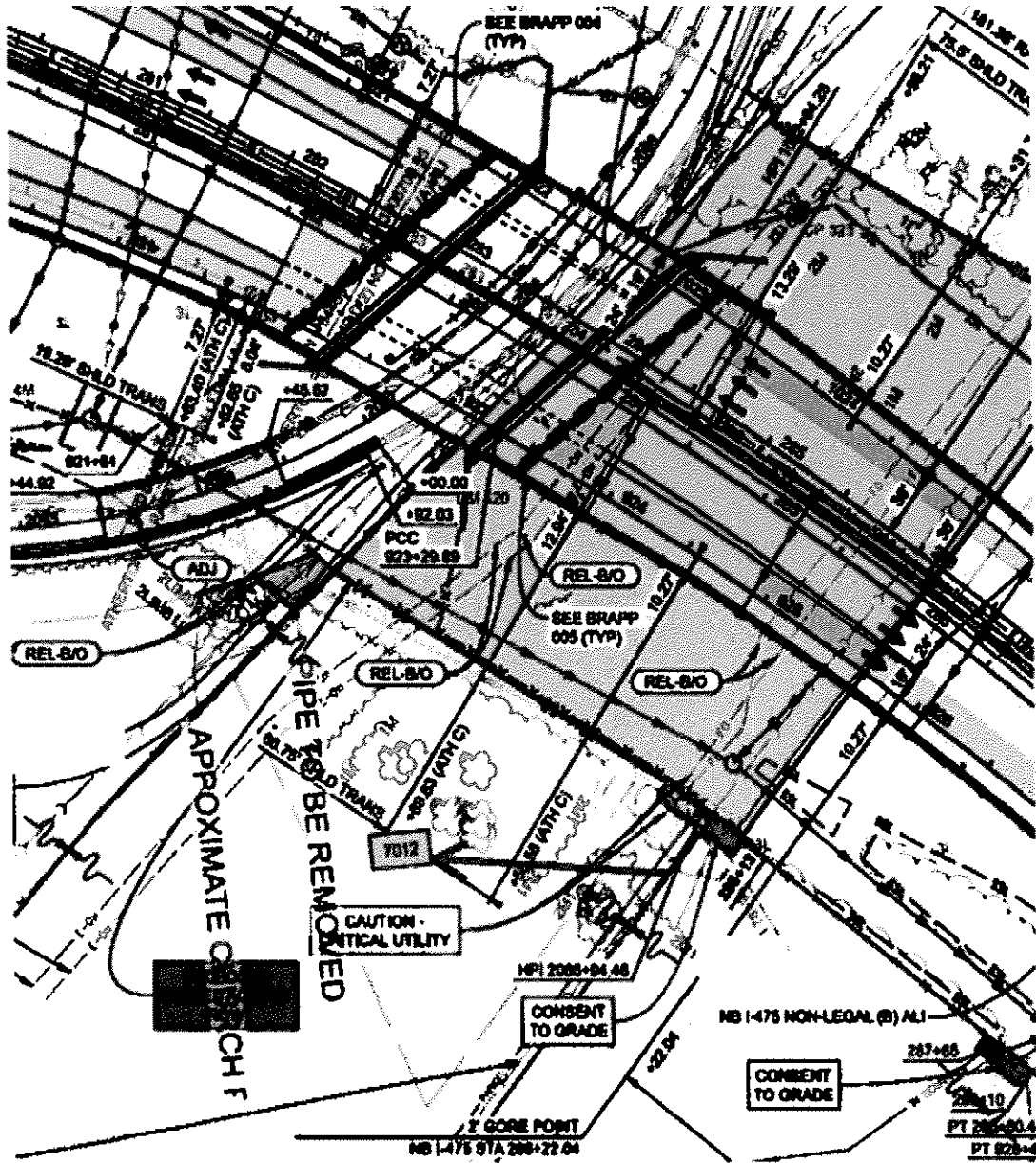

CONTROL SECTION 25132	JOB NUMBER 210086	PARCEL 7012
OWNER OF RECORD CITY OF FLINT		
PROPERTY TAX CODE 41-19-131-021		