

PLAN VIEW OF GRATE

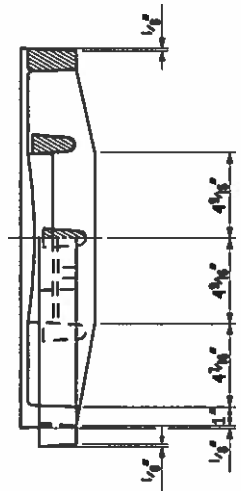

SECTION C - C  
HALF FRONT  
ELEVATION  
OF GRATE

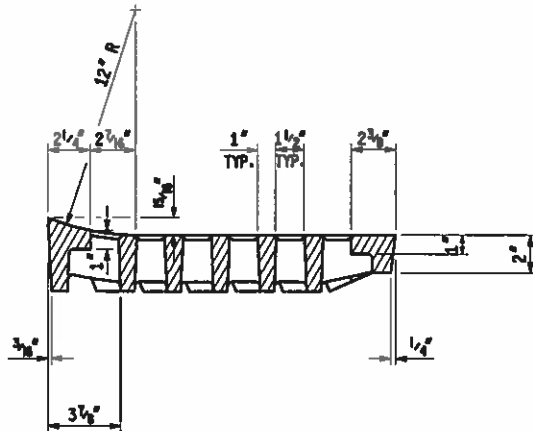

SECTION B - B

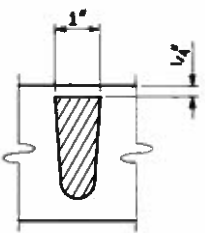

SECTION X - X

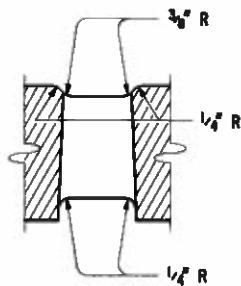

SECTION Y - Y

MICHIGAN DEPARTMENT OF TRANSPORTATION  
BUREAU OF DEVELOPMENT STANDARD PLAN FOR

### COVER K

FOR USE WITH CONCRETE CURB & GUTTER  
DETAILS C, E & F

|     |                   |                        |        |                 |
|-----|-------------------|------------------------|--------|-----------------|
| 231 | F.H.W.A. APPROVAL | 7-26-2019<br>PLAN DATE | R-15-G | SHEET<br>2 OF 3 |
|-----|-------------------|------------------------|--------|-----------------|

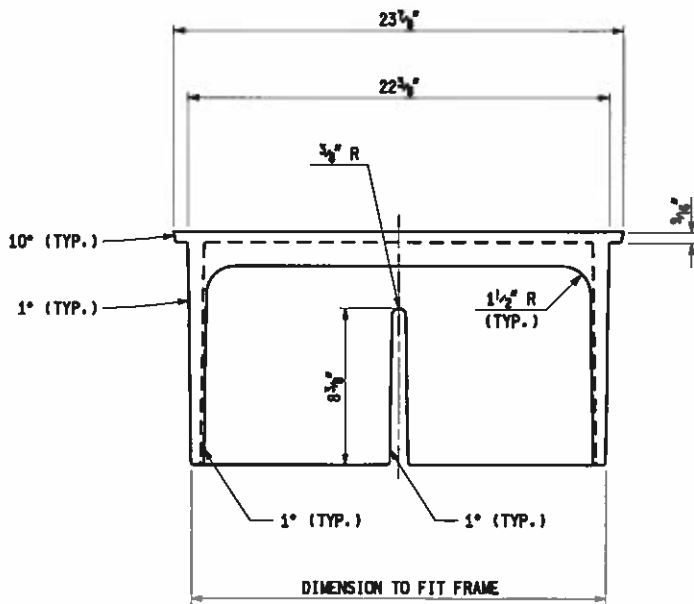

FRONT VIEW OF CURB BOX

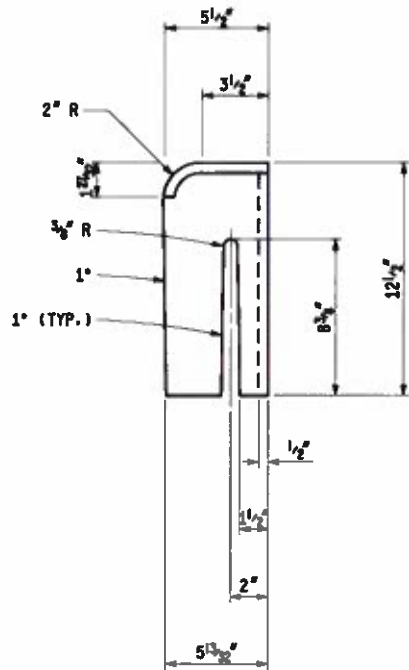

SIDE VIEW

NOTES:

THE CASTINGS SHALL MEET THE REQUIREMENTS OF THE CURRENT STANDARD SPECIFICATION FOR GRAY IRON OR DUCTILE IRON CASTINGS.

ALL CASTINGS SHALL BE CLEANED BY CURRENT APPROVED BLASTING METHODS.

THE SEATING FACE OF THE GRATE AND THE SEAT FOR THE SAME ON THE FRAME SHALL BE GROUND OR MACHINED SO THAT THE GRATE WILL HAVE AN EVEN BEARING ON ITS SEAT TO PREVENT ROCKING OR TILTING.

THE CASTINGS SHALL BE FREE OF POURING FAULTS, BLOW HOLES, CRACKS AND OTHER IMPERFECTIONS. THEY SHALL BE SOUND, TRUE TO FORM AND THICKNESS, CLEAN AND NEATLY FINISHED, AND SHALL BE COATED WITH COAL TAR PITCH VARNISH.

THE CURB BOX AND FRAME SHALL BE SHIPPED ASSEMBLED.

THIS COVER IS DESIGNED TO FIT ON ANY INLET, CATCH BASIN OR ON ANY EXISTING SIMILAR STRUCTURE WHEN SO DESIGNATED ON THE PLANS.

MICHIGAN DEPARTMENT OF TRANSPORTATION  
 BUREAU OF DEVELOPMENT STANDARD PLAN FOR  
**COVER K**  
 FOR USE WITH CONCRETE CURB & GUTTER  
 DETAILS C, E & F

|                   |                        |        |                 |
|-------------------|------------------------|--------|-----------------|
| F.H.W.A. APPROVAL | 7-26-2019<br>PLAN DATE | R-15-G | SHEET<br>3 OF 3 |
|-------------------|------------------------|--------|-----------------|

\* MAXIMUM LANDING SLOPE IS 2.0% IN EACH DIRECTION OF TRAVEL. LANDING MINIMUM DIMENSIONS 5' x 5'. SEE NOTES.

\*\* MAXIMUM RAMP CROSS SLOPE IS 2.0%. RUNNING SLOPE 5% - 7% (8.3% MAXIMUM). SEE NOTES.

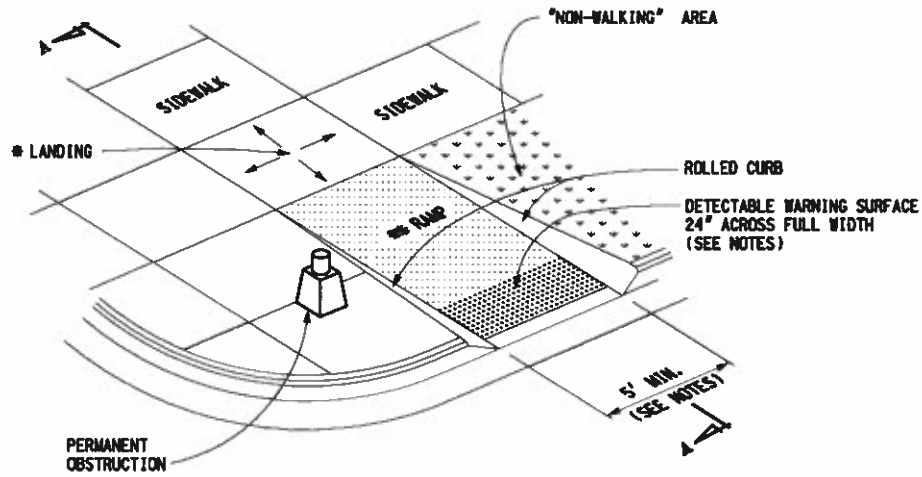

**CURB RAMP TYPE R**  
(ROLLED SIDES)

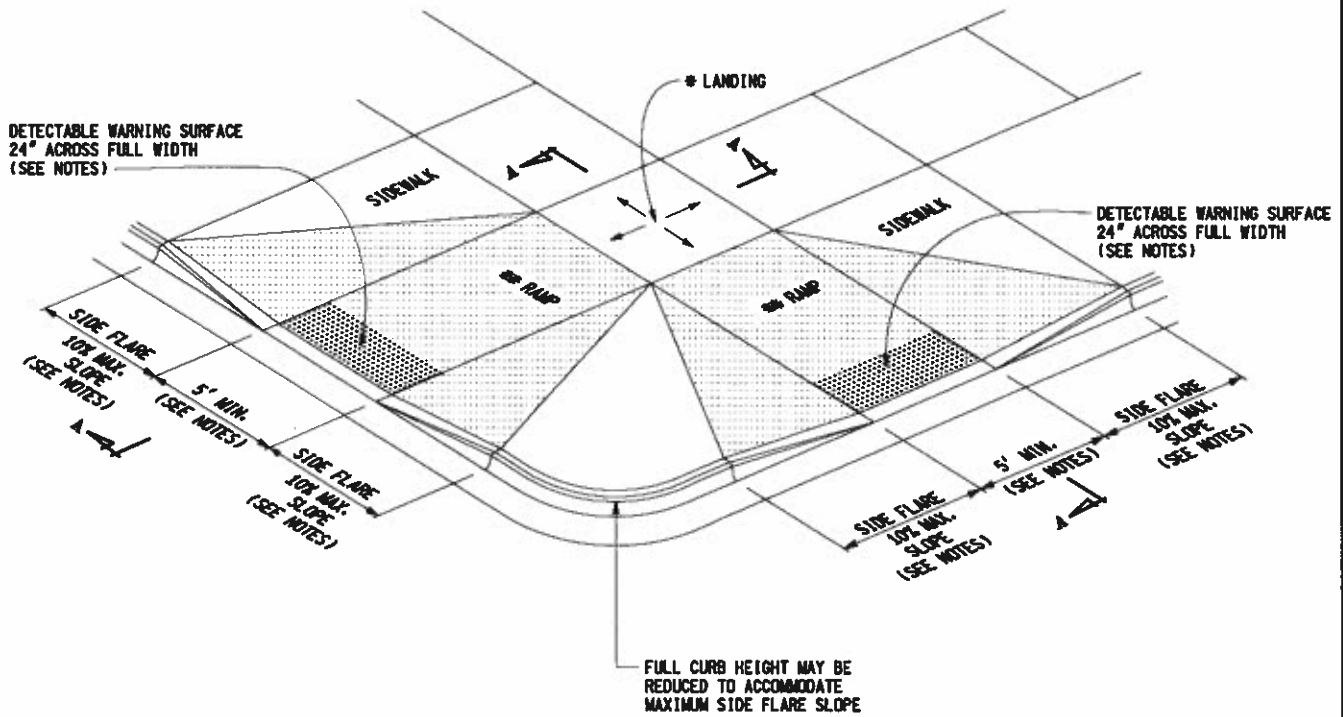

**CURB RAMP TYPE F**  
(FLARED SIDES, TWO RAMPS SHOWN)



DEPARTMENT DIRECTOR  
Paul C. Ajegeba

MICHIGAN DEPARTMENT OF TRANSPORTATION  
BUREAU OF DEVELOPMENT STANDARD PLAN FOR

PREPARED BY  
DESIGN DIVISION

APPROVED BY: \_\_\_\_\_  
DIRECTOR, BUREAU OF FIELD SERVICES

**CURB RAMP AND  
DETECTABLE WARNING DETAILS**

DRAWN BY: B.L.T.

APPROVED BY: \_\_\_\_\_ 233  
DIRECTOR, BUREAU OF DEVELOPMENT

CHECKED BY: W.K.P.

F.H.W.A. APPROVAL

5-8-2020  
PLAN DATE

R-28-J

SHEET  
1 OF 7

\* MAXIMUM LANDING SLOPE IS 2.0% IN EACH DIRECTION OF TRAVEL. LANDING MINIMUM DIMENSIONS 5' x 5'. SEE NOTES.

\*\* MAXIMUM RAMP CROSS SLOPE IS 2.0%. RUNNING SLOPE 5% - 7% (8.3% MAXIMUM). SEE NOTES.

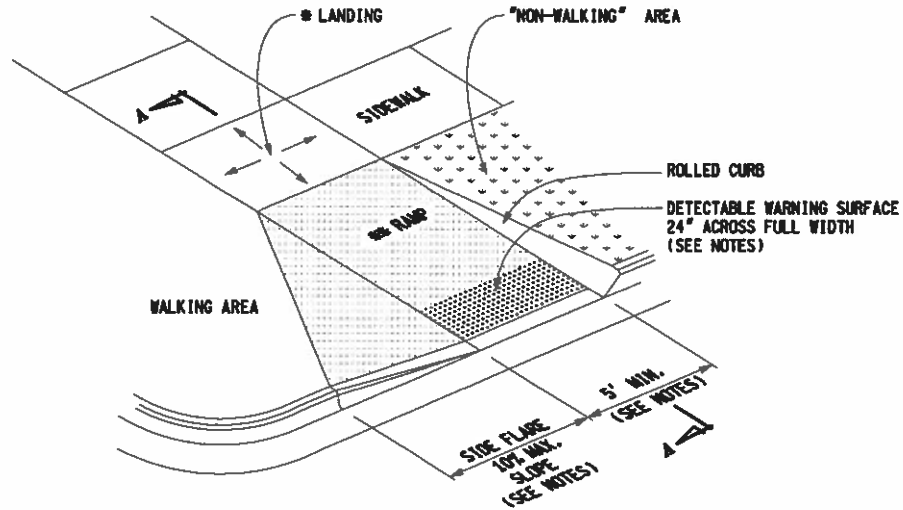

**CURB RAMP TYPE RF**  
(ROLLED / FLARED SIDES)

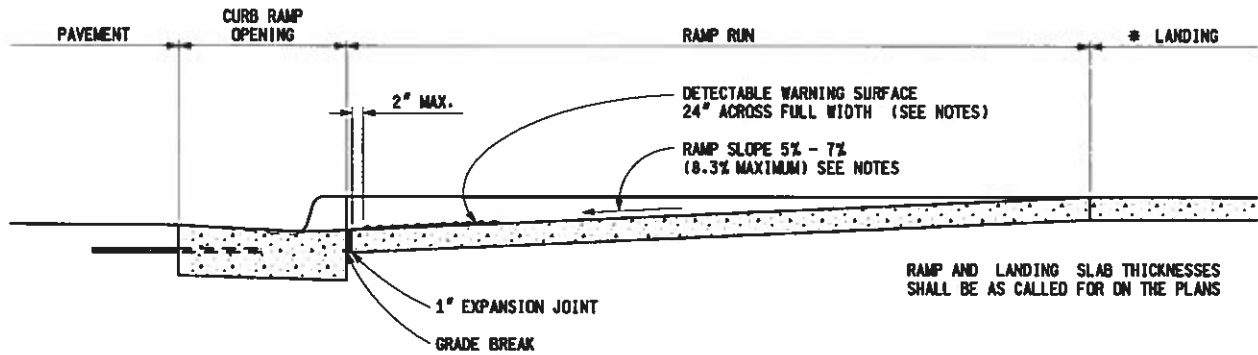

**SECTION A-A**

| CURB TYPE | MAXIMUM RISE (INCHES) |     |
|-----------|-----------------------|-----|
|           | A                     | B   |
| B1        | 3/4                   | 1   |
| B2        | 3/4                   | 1   |
| B3        | 3/4                   | 1   |
| D1        | 3/4                   | 1   |
| D2        | 3/4                   | 1   |
| D3        | 3/4                   | 1   |
| C1        | 1/2                   | 1/2 |
| C2        | 1/2                   | 1/2 |
| C3        | 3/4                   | 1/2 |
| C4        | 3/4                   | 1/2 |
| C5        | 1                     | 1/2 |
| C6        | 1                     | 1/2 |
| F1        | 1/2                   | 1/2 |
| F2        | 1/2                   | 1/2 |
| F3        | 3/4                   | 1/2 |
| F4        | 3/4                   | 1/2 |
| F5        | 1                     | 1/2 |
| F6        | 1                     | 1/2 |

FOR CURB TYPES SEE STANDARD PLAN R-30-SERIES

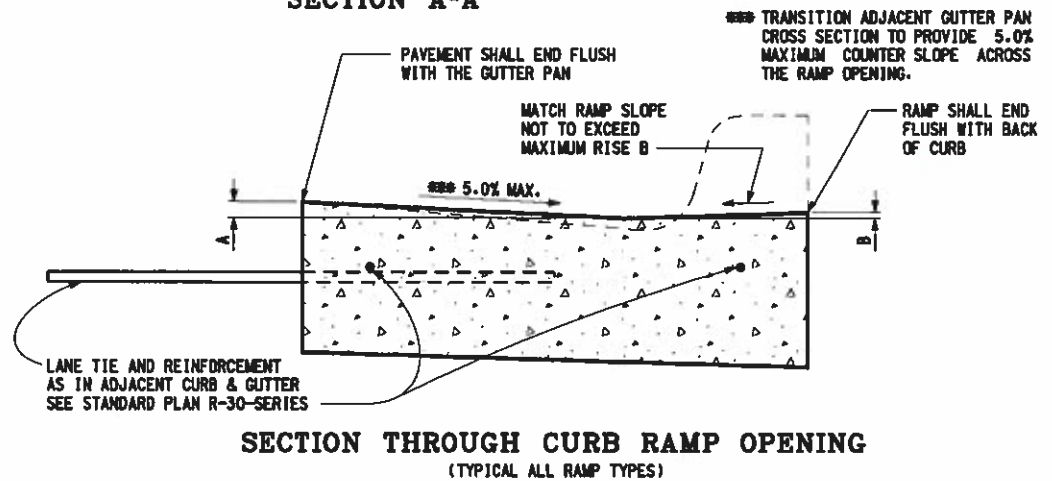

**SECTION THROUGH CURB RAMP OPENING**  
(TYPICAL ALL RAMP TYPES)

MICHIGAN DEPARTMENT OF TRANSPORTATION  
BUREAU OF DEVELOPMENT STANDARD PLAN FOR  
**CURB RAMP AND  
DETECTABLE WARNING DETAILS**

\* MAXIMUM LANDING SLOPE IS 2.0% IN EACH DIRECTION OF TRAVEL. LANDING MINIMUM DIMENSIONS 5' x 5'. SEE NOTES.

\*\* MAXIMUM RAMP CROSS SLOPE IS 2.0%. RUNNING SLOPE 5% - 7% (8.3% MAXIMUM). SEE NOTES.

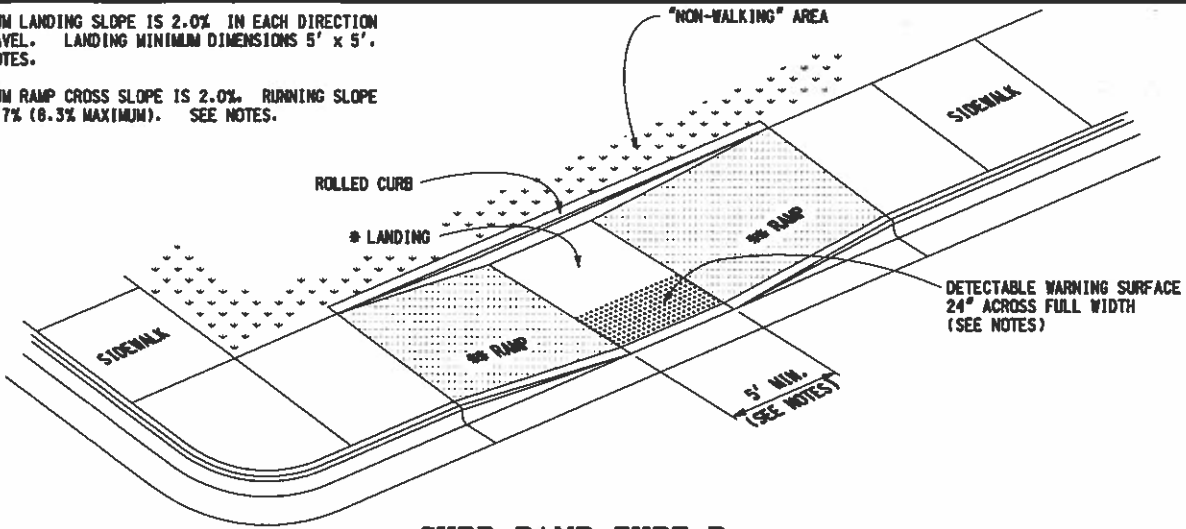

**CURB RAMP TYPE P**

(PARALLEL RAMP)

DO NOT USE IN AREAS WHERE PONDING MAY OCCUR

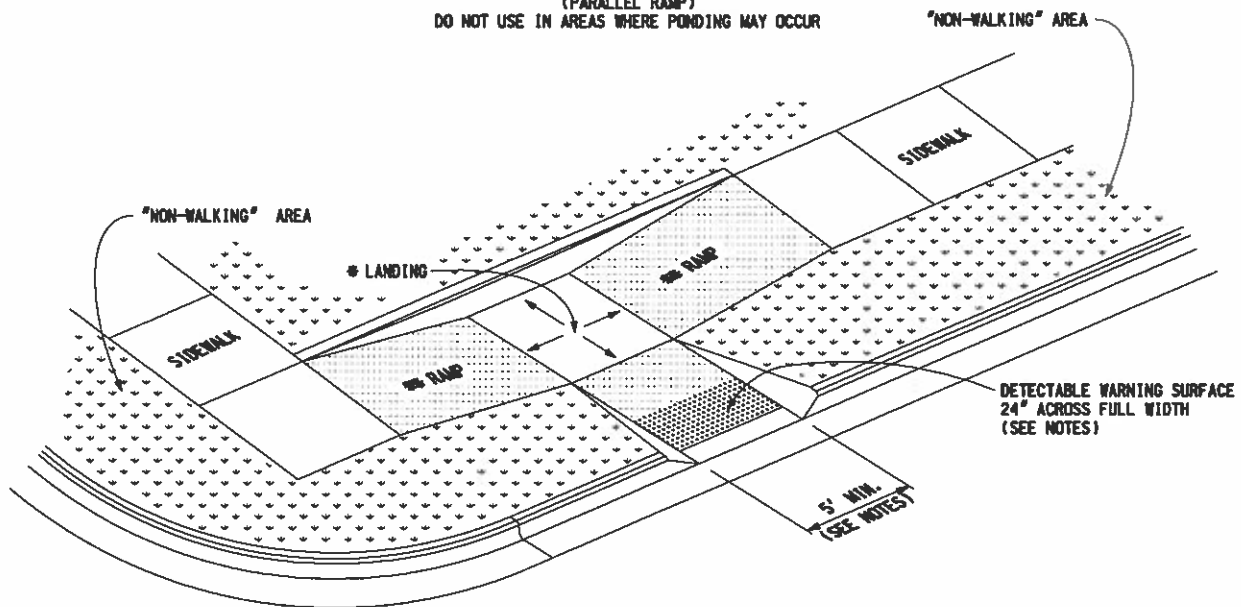

**CURB RAMP TYPE C**

(COMBINATION RAMP)

DETECTABLE WARNING SURFACE 24" ACROSS FULL WIDTH IF MEDIAN WIDTH IS AT LEAST 6'-0". OTHERWISE NO DETECTABLE WARNING IS REQUIRED.

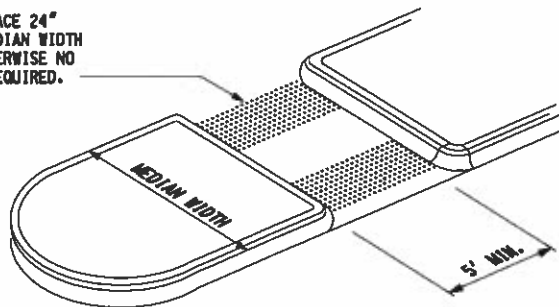

**CURB RAMP TYPE M**

(MEDIAN ISLAND)

MICHIGAN DEPARTMENT OF TRANSPORTATION  
BUREAU OF DEVELOPMENT STANDARD PLAN FOR

**CURB RAMP AND  
DETECTABLE WARNING DETAILS**

\* MAXIMUM LANDING SLOPE IS 2.0% IN EACH DIRECTION OF TRAVEL. LANDING MINIMUM DIMENSIONS 5' x 5'. SEE NOTES.

\*\* MAXIMUM RAMP CROSS SLOPE IS 2.0%. RUNNING SLOPE 5% - 7% (6.3% MAXIMUM). SEE NOTES.

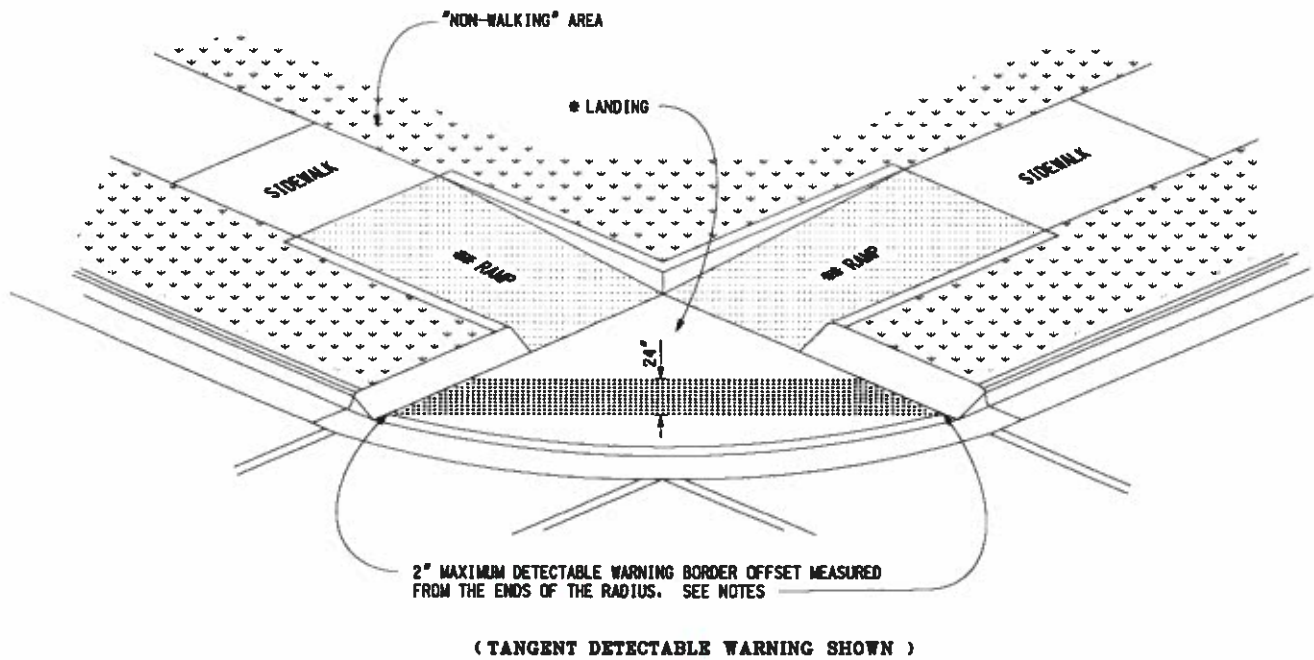
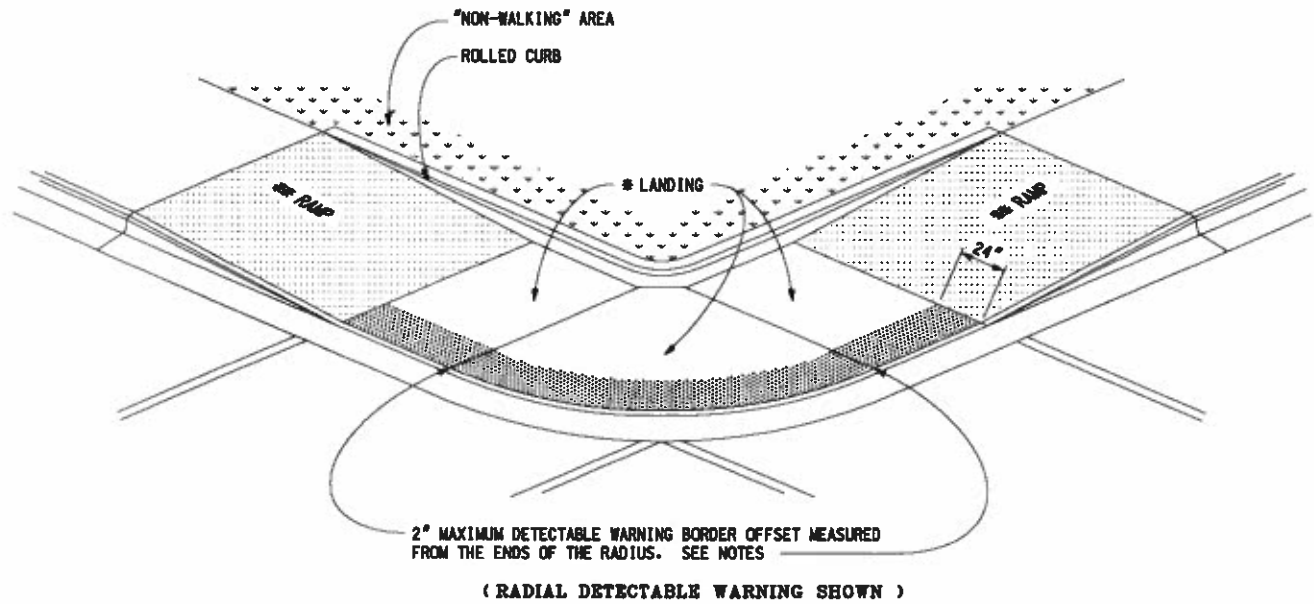

**CURB RAMP TYPE D**  
(DEPRESSED CORNER)

USE ONLY WHEN INDEPENDENT DIRECTIONAL RAMPS CAN NOT BE CONSTRUCTED FOR EACH CROSSING DIRECTION

|  |                       |        |                 |
|--|-----------------------|--------|-----------------|
| MICHIGAN DEPARTMENT OF TRANSPORTATION<br>BUREAU OF DEVELOPMENT STANDARD PLAN FOR |                       |        |                 |
| <b>CURB RAMP AND<br/>DETECTABLE WARNING DETAILS</b>                              |                       |        |                 |
|  | 5-8-2020<br>PLAN DATE | R-28-J | SHEET<br>4 OF 7 |
| 236  | F.H.W.A. APPROVAL     |        |                 |

\* THE DETECTABLE WARNING SURFACE SHALL BE LOCATED SO THAT THE EDGE NEAREST THE RAIL CROSSING IS 6' MINIMUM AND 15' MAXIMUM FROM THE CENTERLINE OF THE NEAREST RAIL. DO NOT PLACE DETECTABLE WARNING ON RAILROAD CROSSING MATERIAL.

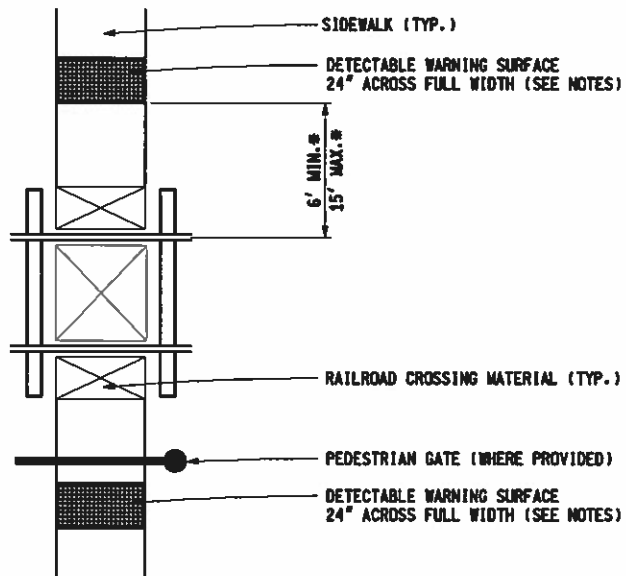

**DETECTABLE WARNING AT RAILROAD CROSSING**

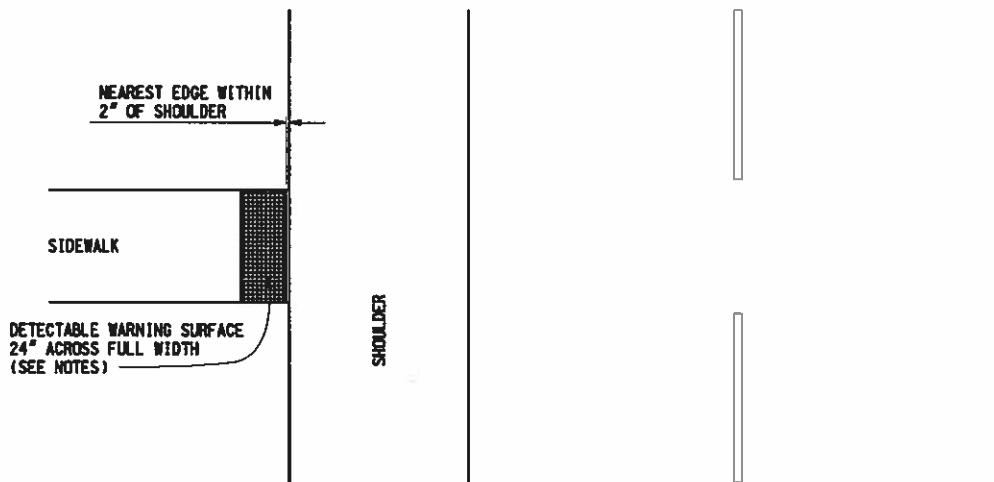

**DETECTABLE WARNING AT FLUSH SHOULDER OR ROADWAY**

|  |                       |                 |
|--|-----------------------|-----------------|
| MICHIGAN DEPARTMENT OF TRANSPORTATION<br>BUREAU OF DEVELOPMENT STANDARD PLAN FOR |                       |                 |
| <b>CURB RAMP AND<br/>         DETECTABLE WARNING DETAILS</b>                     |                       |                 |
| F.H.W.A. APPROVAL  | 5-8-2020<br>PLAN DATE | <b>R-28-J</b>   |
|  |                       | SHEET<br>5 OF 7 |

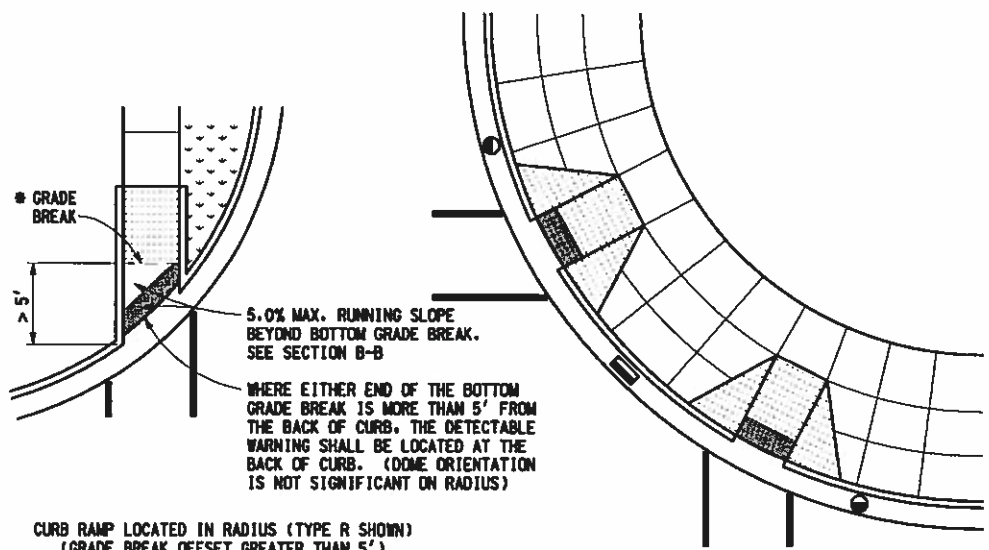

CURB RAMP LOCATED IN RADIUS (TYPE R SHOWN)  
(GRADE BREAK OFFSET GREATER THAN 5')

CURB RAMP PERPENDICULAR TO RADIAL CURB (TYPE F SHOWN)  
(USE WITH RADIAL CURB WHEN THE CROSSWALK AND CURB RAMP ARE NOT ALIGNED)

| LEGEND |   |
|--------|---|
|        | SLOPED SURFACE                              |
|        | DETECTABLE WARNING                          |
|        | "NON-WALKING" AREA                          |
|        | CROSSWALK MARKING                           |
|        | PREFERRED LOCATION OF DRAINAGE INLET (TYP.) |
|        | ALTERNATE LOCATION OF DRAINAGE INLET (TYP.) |

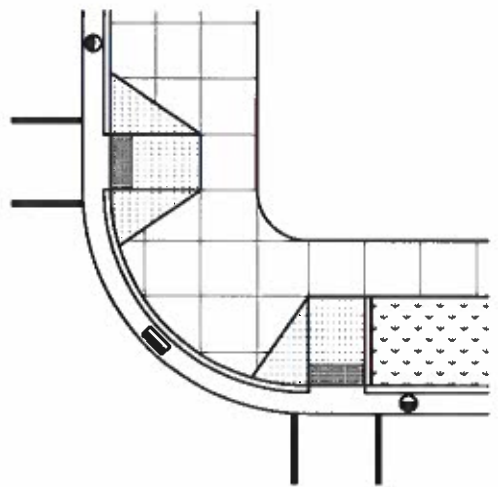

CURB RAMP PERPENDICULAR TO TANGENT CURB  
(TYPE F AND TYPE RF SHOWN)

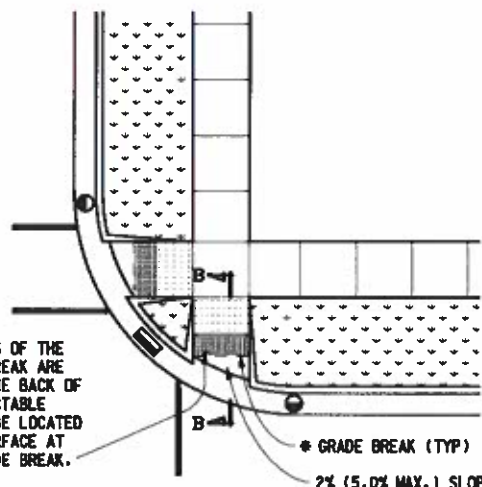

CURB RAMP LOCATED IN RADIUS (TYPE R SHOWN)  
(GRADE BREAK OFFSET LESS THAN 5')

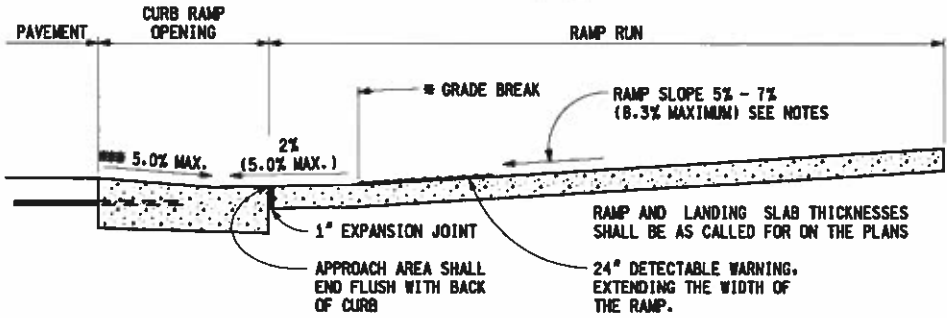

\* GRADE BREAKS AT THE TOP AND BOTTOM OF CURB RAMPS SHALL BE PERPENDICULAR TO THE DIRECTION OF TRAVEL.

\*\*\* TRANSITION ADJACENT GUTTER PAN CROSS SECTION TO PROVIDE 5.0% MAXIMUM COUNTER SLOPE ACROSS THE RAMP OPENING.

SEE SHEET 2 FOR CURB RAMP OPENING DETAILS.

**SECTION B-B  
CURB RAMP ORIENTATION**

MICHIGAN DEPARTMENT OF TRANSPORTATION  
BUREAU OF DEVELOPMENT STANDARD PLAN FOR  
**CURB RAMP AND  
DETECTABLE WARNING DETAILS**



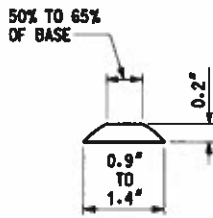

**DOME SECTION**

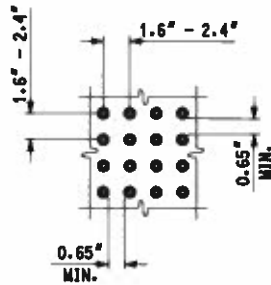

**DOME SPACING**

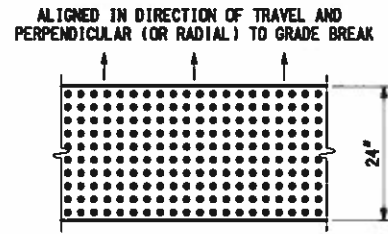

**DOME ALIGNMENT**

**DETECTABLE WARNING DETAILS**

**NOTES:**

DETAILS SPECIFIED ON THIS PLAN APPLY TO ALL CONSTRUCTION, RECONSTRUCTION, OR ALTERATION OF STREETS, CURBS, OR SIDEWALKS IN THE PUBLIC RIGHT OF WAY.

CURB RAMPS ARE TO BE LOCATED AS SPECIFIED ON THE PLANS OR AS DIRECTED BY THE ENGINEER.

RAMPS SHALL BE PROVIDED AT ALL CORNERS OF AN INTERSECTION WHERE THERE IS EXISTING OR PROPOSED SIDEWALK AND CURB. RAMPS SHALL ALSO BE PROVIDED AT MARKED AND/OR SIGNALIZED MID-BLOCK CROSSINGS.

SURFACE TEXTURE OF THE RAMP SHALL BE THAT OBTAINED BY A COARSE BROOMING, TRANSVERSE TO THE RUNNING SLOPE.

SIDEWALK SHALL BE RAMPED WHERE THE DRIVEWAY CURB IS EXTENDED ACROSS THE WALK.

CARE SHALL BE TAKEN TO ASSURE A UNIFORM GRADE ON THE RAMP. WHERE CONDITIONS PERMIT, IT IS DESIRABLE THAT THE SLOPE OF THE RAMP BE IN ONLY ONE DIRECTION, PARALLEL TO THE DIRECTION OF TRAVEL.

RAMP WIDTH SHALL BE INCREASED, IF NECESSARY, TO ACCOMMODATE SIDEWALK SNOW REMOVAL EQUIPMENT NORMALLY USED BY THE MUNICIPALITY.

WHEN 5' MINIMUM WIDTHS ARE NOT PRACTICABLE, RAMP WIDTH MAY BE REDUCED TO NOT LESS THAN 4' AND LANDINGS TO NOT LESS THAN 4' x 4'.

CURB RAMPS WITH A RUNNING SLOPE  $\leq 5\%$  DO NOT REQUIRE A TOP LANDING. HOWEVER, ANY CONTINUOUS SIDEWALK OR PEDESTRIAN ROUTE CROSSING THROUGH OR INTERSECTING THE CURB RAMP MUST INDEPENDENTLY MAINTAIN A CROSS SLOPE NOT GREATER THAN 2% PERPENDICULAR TO ITS OWN DIRECTION(S) OF TRAVEL.

DETECTABLE WARNING SURFACE COVERAGE IS 24" MINIMUM IN THE DIRECTION OF RAMP/PATH TRAVEL AND THE FULL WIDTH OF THE RAMP/PATH OPENING EXCLUDING CURBED OR FLARED CURB TRANSITION AREAS. A BORDER OFFSET NOT GREATER THAN 2" MEASURED ALONG THE EDGES OF THE DETECTABLE WARNING IS ALLOWABLE. FOR RADIAL CURB THE OFFSET IS MEASURED FROM THE ENDS OF THE RADIUS.

FOR NEW ROADWAY CONSTRUCTION, THE RAMP CROSS SLOPE MAY NOT EXCEED 2.0%. FOR ALTERATIONS TO EXISTING ROADWAYS, THE CROSS SLOPE MAY BE TRANSITIONED TO MEET AN EXISTING ROADWAY GRADE. THE CROSS SLOPE TRANSITION SHALL BE APPLIED UNIFORMLY OVER THE FULL LENGTH OF THE RAMP.

THE MAXIMUM RUNNING SLOPE OF 8.3% IS RELATIVE TO A FLAT (0%) REFERENCE. HOWEVER, IT SHALL NOT REQUIRE ANY RAMP OR SERIES OF RAMPS TO EXCEED 15 FEET IN LENGTH NOT INCLUDING LANDINGS OR TRANSITIONS.

DRAINAGE STRUCTURES SHOULD NOT BE PLACED IN LINE WITH RAMPS. THE LOCATION OF THE RAMP SHOULD TAKE PRECEDENCE OVER THE LOCATION OF THE DRAINAGE STRUCTURE. WHERE EXISTING DRAINAGE STRUCTURES ARE LOCATED IN THE RAMP PATH OF TRAVEL, USE A MANUFACTURER'S ADA COMPLIANT GRATE. OPENINGS SHALL NOT BE GREATER THAN 1/2". ELONGATED OPENINGS SHALL BE PLACED SO THAT THE LONG DIMENSION IS PERPENDICULAR TO THE DOMINANT DIRECTION OF TRAVEL.

THE TOP OF THE JOINT FILLER FOR ALL RAMP TYPES SHALL BE FLUSH WITH THE ADJACENT CONCRETE.

CROSSWALK AND STOP LINE MARKINGS, IF USED, SHALL BE SO LOCATED AS TO STOP TRAFFIC SHORT OF RAMP CROSSINGS. SPECIFIC DETAILS FOR MARKING APPLICATIONS ARE GIVEN IN THE "MICHIGAN MANUAL ON UNIFORM TRAFFIC CONTROL DEVICES".

FLARED SIDES WITH A SLOPE OF 10% MAXIMUM, MEASURED ALONG THE ROADSIDE CURB LINE, SHALL BE PROVIDED WHERE AN UNOBSTRUCTED CIRCULATION PATH LATERALLY CROSSES THE CURB RAMP. FLARED SIDES ARE NOT REQUIRED WHERE THE RAMP IS BORDERED BY LANDSCAPING, UNPAVED SURFACE OR PERMANENT FIXED OBJECTS. WHERE THEY ARE NOT REQUIRED, FLARED SIDES CAN BE CONSIDERED IN ORDER TO AVOID SHARP CURB RETURNS AT RAMP OPENINGS.

DETECTABLE WARNING PLATES MUST BE INSTALLED USING FABRICATED OR FIELD CUT UNITS CAST AND/OR ANCHORED IN THE PAVEMENT TO RESIST SHIFTING OR HEAVING.

MICHIGAN DEPARTMENT OF TRANSPORTATION  
BUREAU OF DEVELOPMENT STANDARD PLAN FOR  
**CURB RAMP AND  
DETECTABLE WARNING DETAILS**

|                   |                       |        |                 |
|-------------------|-----------------------|--------|-----------------|
| F.H.W.A. APPROVAL | 5-8-2020<br>PLAN DATE | R-28-J | SHEET<br>7 OF 7 |
|-------------------|-----------------------|--------|-----------------|

## NOTICE TO BIDDERS – INQUIRY

All inquiries concerning the plans and proposal for this project are to be directed to:

Brent Schriener

Name

Urban Staff Engineer

Title

schrinerb@michigan.gov

E-mail Address

517-241-2911

Phone

**All inquiries must be made by E-mail through the electronic proposal system at MDOT's e-Proposal website – [www.michigan.gov/mdot-eprop](http://www.michigan.gov/mdot-eprop).** Telephone inquiries will not be answered. To be able to process and distribute an addendum, if required, all inquiries shall be made at least seven (7) calendar days before the letting. Inquiries made after this date will be considered by MDOT, but will not require a response.

Inquiries made by E-mail must include the following information:

Proposal Item Number

Contract ID

Name of Inquiring Person

Company Name

Phone # and E-mail address

Detailed question(s) with reference to proposal page and plan sheet number

Other employees of MDOT have been instructed to direct all inquiries to the person mentioned above.

2/11/2009

Job(s): 207665A

"General Decision Number: MI20210001 06/18/2021

Superseded General Decision Number: MI20200001

State: Michigan

Construction Types: Highway (Highway, Airport & Bridge xxxxx and Sewer/Incid. to Hwy.)

Counties: Michigan Statewide.

Note: Under Executive Order (EO) 13658, an hourly minimum wage of \$10.95 for calendar year 2021 applies to all contracts subject to the Davis-Bacon Act for which the contract is awarded (and any solicitation was issued) on or after January 1, 2015. If this contract is covered by the EO, the contractor must pay all workers in any classification listed on this wage determination at least \$10.95 per hour (or the applicable wage rate listed on this wage determination, if it is higher) for all hours spent performing on the contract in calendar year 2021. If this contract is covered by the EO and a classification considered necessary for performance of work on the contract does not appear on this wage determination, the contractor must pay workers in that classification at least the wage rate determined through the conformance process set forth in 29 CFR 5.5(a)(1)(ii) (or the EO minimum wage rate, if it is higher than the conformed wage rate). The EO minimum wage rate will be adjusted annually. Please note that this EO applies to the above-mentioned types of contracts entered into by the federal government that are subject to the Davis-Bacon Act itself, but it does not apply to contracts subject only to the Davis-Bacon Related Acts, including those set forth at 29 CFR 5.1(a)(2)-(60). Additional information on contractor requirements and worker protections under the EO is available at [www.dol.gov/whd/govcontracts](http://www.dol.gov/whd/govcontracts).

| Modification Number | Publication Date |
|---------------------|------------------|
| 0                   | 01/01/2021       |
| 1                   | 03/12/2021       |
| 2                   | 05/07/2021       |
| 3                   | 06/04/2021       |
| 4                   | 06/18/2021       |

CARP0004-004 06/01/2019

REMAINDER OF STATE

|                              | Rates    | Fringes |
|------------------------------|----------|---------|
| CARPENTER ( Piledriver)..... | \$ 27.62 | 20.59   |

-----  
 CARP0004-005 06/01/2018

LIVINGSTON (Townships of Brighton, Deerfield, Genoa, Hartland, Oceola & Tyrone), MACOMB, MONROE, OAKLAND, SANILAC, ST. CLAIR AND WAYNE COUNTIES

|                             | Rates    | Fringes |
|-----------------------------|----------|---------|
| CARPENTER (Piledriver)..... | \$ 30.50 | 27.28   |

-----  
 ELEC0017-005 06/01/2020

STATEWIDE

|   | Rates    | Fringes |
|---|----------|---------|
| Line Construction   |          |         |
| Groundman/Driver.....   | \$ 28.84 | 16.03   |
| Journeyman Signal Tech,<br>Communications Tech, Tower<br>Tech & Fiber Optic Splicers. | \$ 41.44 | 20.00   |
| Journeyman Specialist.....  | \$ 47.66 | 21.96   |
| Operator A.....   | \$ 35.02 | 17.99   |
| Operator B.....   | \$ 32.69 | 17.25   |

Classifications

Journeyman Specialist: Refers to a crew of only one person working alone.  
 Operator A: Shall be proficient in operating all power equipment including: Backhoe, Excavator, Directional Bore and Boom/Digger truck.  
 Operator B: Shall be proficient in operating any 2 of the above mentioned pieces of equipment listed under Operator A.

-----  
 ENGI0324-003 06/01/2020

ALCONA, ALPENA, ARENAC, BAY, CHEBOYGAN, CLARE, CLINTON, CRAWFORD, GENESEE, GLADWIN, GRATIOT, HURON, INGHAM, IOSCO, ISABELLA, JACKSON, LAPEER, LENAWEE, LIVINGSTON, MACOMB, MIDLAND, MONROE, MONTMORENCY, OAKLAND, OGEMAW, OSCODA, OTSEGO, PRESQUE ISLE, ROSCOMMON, SAGINAW, ST. CLAIR, SANILAC, SHIAWASSEE, TUSCOLA, WASHTENAW AND WAYNE COUNTIES:

|   | Rates    | Fringes |
|---|----------|---------|
| OPERATOR: Power Equipment<br>(Steel Erection) |          |         |
| GROUP 1.....                                  | \$ 47.02 | 24.85   |
| GROUP 2.....                                  | \$ 48.02 | 24.85   |
| GROUP 3.....                                  | \$ 45.52 | 24.85   |
| GROUP 4.....                                  | \$ 46.52 | 24.85   |
| GROUP 5.....                                  | \$ 44.02 | 24.85   |
| GROUP 6.....                                  | \$ 45.02 | 24.85   |
| GROUP 7.....                                  | \$ 43.75 | 24.85   |
| GROUP 8.....                                  | \$ 44.75 | 24.85   |
| GROUP 9.....                                  | \$ 43.30 | 24.85   |
| GROUP 10.....                                 | \$ 44.30 | 24.85   |
| GROUP 11.....                                 | \$ 42.57 | 24.85   |
| GROUP 12.....                                 | \$ 43.57 | 24.85   |
| GROUP 13.....                                 | \$ 42.21 | 24.85   |
| GROUP 14.....                                 | \$ 43.21 | 24.85   |
| GROUP 15.....                                 | \$ 41.57 | 24.85   |
| GROUP 16.....                                 | \$ 38.62 | 24.85   |
| GROUP 17.....                                 | \$ 24.14 | 12.00   |
| GROUP 18.....                                 | \$ 27.63 | 12.00   |

FOOTNOTE:

Paid Holidays: New Year's Day, Memorial Day, Fourth of July, Labor Day, Thanksgiving Day and Christmas Day.

POWER EQUIPMENT OPERATOR CLASSIFICATIONS

GROUP 1: Engineer when operating combination of boom and jib 400' or longer

GROUP 2: Engineer when operating combination of boom and jib 400' or longer on a crane that requires an oiler

GROUP 3: Engineer when operating combination of boom and jib 300' or longer

GROUP 4: Engineer when operating combination of boom and jib 300' or longer on a crane that requires an oiler

GROUP 5: Engineer when operating combination of boom and jib 220' or longer

GROUP 6: Engineer when operating combination of boom and jib 220' or longer on a crane that requires an oiler

GROUP 7: Engineer when operating combination of boom and jib 140' or longer

GROUP 8: Engineer when operating combination of boom and jib 140' or longer on a crane that requires an oiler

GROUP 9: Tower crane & derrick operator (where operator's work station is 50 ft. or more above first sub-level)

GROUP 10: Tower crane & derrick operator (where operator's work station is 50 ft. or more above first sub-level) on a crane that requires an oiler

GROUP 11: Engineer when operating combination of boom and jib 120' or longer

GROUP 12: Engineer when operating combination of boom and jib 120' or longer on a crane that requires an oiler

GROUP 13: Crane operator; job mechanic and 3 drum hoist and excavator

GROUP 14: Crane operator on a crane that requires an oiler

GROUP 15: Hoisting operator; 2 drum hoist and rubber tired backhoe

GROUP 16: Forklift and 1 drum hoist

GROUP 17: Compressor or welder operator

GROUP 18: Oiler

-----  
ENGI0324-004 06/01/2020

AREA 1: ALLEGAN, BARRY, BERRIEN, BRANCH, CALHOUN, CASS, EATON, HILLSDALE, IONIA, KALAMAZOO, KENT, LAKE, MANISTEE, MASON, MECOSTA, MONTCALM, MUSKEGON, NEWAYGO, OCEANA, OSCEOLA, OTTAWA, ST. JOSEPH, VAN BUREN

AREA 2: ANTRIM, BENZIE, CHARLEVOIX, EMMET, GRAND TRAVERSE, KALKASKA, LEELANAU, MISSAUKEE AND WEXFORD COUNTIES:

OPERATOR: Power Equipment  
(Steel Erection)

Rates

Fringes

AREA 1

|              |          |       |
|--------------|----------|-------|
| GROUP 1..... | \$ 47.02 | 24.85 |
| GROUP 2..... | \$ 43.75 | 24.85 |
| GROUP 3..... | \$ 42.21 | 24.85 |
| GROUP 4..... | \$ 38.62 | 24.85 |
| GROUP 5..... | \$ 24.14 | 12.00 |
| GROUP 6..... | \$ 27.63 | 12.00 |

AREA 2

|              |          |       |
|--------------|----------|-------|
| GROUP 1..... | \$ 47.02 | 24.85 |
| GROUP 2..... | \$ 43.75 | 24.85 |
| GROUP 3..... | \$ 42.21 | 24.85 |
| GROUP 4..... | \$ 38.62 | 24.85 |
| GROUP 5..... | \$ 24.14 | 12.00 |
| GROUP 6..... | \$ 27.63 | 12.00 |

FOOTNOTES:

Crane operator with main boom and jib 300' or longer: \$1.50 additional to the group 1 rate. Crane operator with main boom and jib 400' or longer: \$3.00 additional to the group 1 rate.

PAID HOLIDAYS: New Year's Day, Memorial Day, Fourth of July, Labor Day, Thanksgiving Day and Christmas Day.

POWER EQUIPMENT OPERATOR CLASSIFICATIONS:

GROUP 1: Crane Operator with main boom & jib 400', 300', or 220' or longer.

GROUP 2: Crane Operator with main boom & jib 140' or longer, Tower Crane; Gantry Crane; Whirley Derrick.

GROUP 3: Regular Equipment Operator, Crane, Dozer, Loader, Hoist, Straddle Wagon, Mechanic, Grader and Hydro Excavator.

GROUP 4: Air Tugger (single drum), Material Hoist Pump 6" or over, Elevators, Brokk Concrete Breaker.

GROUP 5: Air Compressor, Welder, Generators, Conveyors

GROUP 6: Oiler and fire tender

-----  
ENGI0324-005 09/01/2020

AREA 1: GENESEE, LAPEER, LIVINGSTON, MACOMB, MONROE, OAKLAND, ST. CLAIR, WASHTENAW AND WAYNE COUNTIES

AREA 2: ALCONA, ALLEGAN, ALGER, ALPENA, ANTRIM, ARENAC, BARAGA, BARRY, BAY, BENZIE, BERRIEN, BRANCH, CALHOUN, CASS, CHARLEVOIX, CHEBOYGAN, CHIPPEWA, CLARE, CLINTON, CRAWFORD, DELTA, DICKINSON, EATON, EMMET, GLADWIN, GOGEBIC, GRAND TRAVERSE, GRATIOT, HILLSDALE, HOUGHTON, HURON, INGHAM, IONIA, IOSCO, IRON, ISABELLA, JACKSON, KALAMAZOO, KALKASKA, KENT, KWEENAW, LAKE, LEELANAU, LENAWEE, LUCE, MACKINAC, MANISTEE, MARQUETTE, MASON, MECOSTA, MENOMINEE, MIDLAND, MISSAUKEE, MONTCALM, MONTMORENCY, MUSKEGON, NEWAYGO, OCEANA, OGEMAW, ONTONAGON, OSCEOLA, OSCODA, OTSEGO, OTTAWA, PRESQUE ISLE, ROSCOMMON, SAGINAW, SANILAC, SCHOOLCRAFT, SHIAWASSEE, ST. JOSEPH, TUSCOLA, VAN BUREN AND WEXFORD COUNTIES

|                           | Rates    | Fringes |
|---------------------------|----------|---------|
| OPERATOR: Power Equipment |          |         |
| (Underground construction |          |         |
| (including sewer))        |          |         |
| AREA 1:                   |          |         |
| GROUP 1.....              | \$ 35.88 | 24.85   |
| GROUP 2.....              | \$ 31.15 | 24.85   |
| GROUP 3.....              | \$ 30.42 | 24.85   |
| GROUP 4.....              | \$ 29.85 | 24.85   |
| GROUP 5.....              | \$ 21.40 | 12.05   |
| AREA 2:                   |          |         |
| GROUP 1.....              | \$ 34.17 | 24.85   |
| GROUP 2.....              | \$ 29.28 | 24.85   |
| GROUP 3.....              | \$ 28.78 | 24.85   |
| GROUP 4.....              | \$ 28.50 | 24.85   |
| GROUP 5.....              | \$ 21.40 | 12.05   |

POWER EQUIPMENT OPERATOR CLASSIFICATIONS

GROUP 1: Backfiller tamper; Backhoe; Batch plant operator (concrete); Clamshell; Concrete paver (2 drums or larger); Conveyor loader (Euclid type); Crane (crawler, truck type or pile driving); Dozer; Dragline; Elevating grader; Endloader; Gradall (and similar type machine); Grader; Mechanic; Power shovel; Roller (asphalt); Scraper (self-propelled or tractor drawn); Side boom tractor (type D-4 or equivalent and larger); Slip form paver; Slope paver; Trencher (over 8 ft. digging capacity); Well drilling rig; Concrete pump with boom operator; Hydro Excavator

GROUP 2: Boom truck (power swing type boom); Crusher; Hoist; Pump (1 or more - 6-in. discharge or larger - gas or diesel- powered or powered by generator of 300 amperes or



more - inclusive of generator); Side boom tractor (smaller than type D-4 or equivalent); Tractor (pneu-tired, other than backhoe or front end loader); Trencher (8-ft. digging capacity and smaller); Vac Truck and End dump operator;

GROUP 3: Air compressors (600 cfm or larger); Air compressors (2 or more-less than 600 cfm); Boom truck (non-swinging, non-powered type boom); Concrete breaker (self-propelled or truck mounted - includes compressor); Concrete paver (1 drum-1/2 yd. or larger); Elevator (other than passenger); Maintenance person; Pump (2 or more-4-in. up to 6-in. discharge-gas or diesel powered - excluding submersible pumps); Pumpcrete machine (and similar equipment); Wagon drill (multiple); Welding machine or generator (2 or more-300 amp. or larger - gas or diesel powered)

GROUP 4: Boiler; Concrete saw (40 hp or over); Curing machine (self-propelled); Farm tractor (with attachment); Finishing machine (concrete); Hydraulic pipe pushing machine; Mulching equipment; Pumps (2 or more up to 4-in. discharge, if used 3 hours or more a day, gas or diesel powered - excluding submersible pumps); Roller (other than asphalt); Stump remover; Trencher (service); Vibrating compaction equipment, self-propelled (6 ft. wide or over); Sweeper (Wayne type); Water wagon and Extend-a boom forklift

Group 5: Fire Person, Oiler

---

\* ENGI0324-006 06/01/2021

GENESEE, MACOMB, MONROE, OAKLAND, WASHTENAW, WAYNE, ALCONA, ALGER, ALLEGAN, ALPENA, ANTRIM, ARENAC, BARAGA, BARRY, BAY, BENZIE, BERRIEN, BRANCH, CALHOUN, CASS, CHARLEVOIX, CHEBOYGAN, CHIPPEWA, CLARE, CLINTON, CRAWFORD, DELTA, DICKINSON, EATON, EMMET, GLADWIN, GOGEBIC, GRAND TRAVERSE, GRATIOT, HILLSDALE, HOUGHTON, HURON, INGHAM, IONIA, IOSCO, IRON, ISABELLA, JACKSON, KALAMAZOO, KALKASKA, KENT, KEWEENAW, LAKE, LAPEER, LEELANAU, LENAWEE, LIVINGSTON, LUCE, MACKINAC, MANISTEE, MARQUETTE, MASON, MECOSTA, MENOMINEE, MIDLAND, MISSAUKEE, MONTCALM, MONTMORENCY, MUSKEGON, NEWAYGO, OCEANA, OGEMAW, ONTONAGON, OSCEOLA, OSCODA, OTSEGO, OTTAWA, PRESQUE ISLE, ROSCOMMON, SAGINAW, ST. CLARE, ST. JOSEPH, SANILAC, SCHOOLCRAFT, SHIAWASSEE, TUSCOLA, VAN BUREN AND WEXFORD COUNTIES

|   | Rates    | Fringes |
|---|----------|---------|
| Power equipment operators:<br>(AIRPORT, BRIDGE & HIGHWAY<br>CONSTRUCTION) |          |         |
| GROUP 1.....  | \$ 36.86 | 24.85   |
| GROUP 2.....  | \$ 28.18 | 24.85   |
| GROUP 3.....  | \$ 27.62 | 24.85   |
| GROUP 4.....  | \$ 27.45 | 24.85   |

#### POWER EQUIPMENT OPERATOR CLASSIFICATIONS

GROUP 1: Asphalt plant operator; Crane operator (does not include work on bridge construction projects when the crane operator is erecting structural components); Dragline operator; Shovel operator; Locomotive operator; Paver operator (5 bags or more); Elevating grader operator; Pile driving operator; Roller operator (asphalt); Blade grader operator; Trenching machine operator (ladder or wheel type); Auto-grader; Slip form paver; Self-propelled or tractor-drawn scraper; Conveyor loader operator (Euclid type); Endloader operator (1 yd. capacity and over); Bulldozer; Hoisting engineer; Tractor operator; Finishing machine operator (asphalt); Mechanic; Pump operator (6-in. discharge or over, gas, diesel powered or generator of 300 amp. or larger); Shouldering or gravel distributing machine operator (self-propelled); Backhoe (with over 3/8 yd. bucket); Side boom tractor (type D-4 or equivalent or larger); Tube finisher (slip form paving); Gradall (and similar type machine); Asphalt paver (self-propelled); Asphalt planer (self-propelled); Batch plant (concrete-central mix); Slurry machine (asphalt); Concrete pump (3 in. and over); Roto-mill; Swinging boom truck (over 12 ton capacity); Hydro demolisher (water blaster); Farm-type tractor with attached pan; Vacuum truck operator; Batch Plant (concrete dry batch); Concrete Saw Operator (40h.p. or over; Tractor Operator (farm type); Finishing Machine Operator (concrete); Grader Operator (self-propelled fine grade or form (concrete)).

GROUP 2: Screening plant operator; Washing plant operator; Crusher operator; Backhoe (with 3/8 yd. bucket or less); Side boom tractor (smaller than D-4 type or equivalent); Sweeper (Wayne type and similar equipment); Greese Truck; Air Compressor Operator (600 cu.ft. per min or more); Air Compressor Operator (two or more, less than 600 cfm);

GROUP 3: Boiler fire tender; Tractor operator (farm type with attachment); Concrete Breaker; Wagon Drill Operator;

GROUP 4: Oiler; Fire tender; Trencher (service); Flexplane operator; Cleftplane operator; Boom or winch hoist truck operator; Endloader operator \*under 1 yd. capacity); Roller Operator (other than asphalt); Curing equipment operator (self-propelled); Power bin operator; Plant drier (6 ft. wide or over); Guard post driver operator (power driven); All mulching equipment; Stump remover; Concrete pump (under 3-in.); Mesh installer (self-propelled); End dump; Skid Steer.

-----  
 ENGI0324-007 05/01/2020

ALGER, BARAGA, CHIPPEWA, DELTA, DICKINSON, GOGEBIC, HOUGHTON, IRON, KEWEENAW, LUCE, MACKINAC MARQUETTE, MENOMINEE, ONTONAGON AND SCHOOLCRAFT COUNTIES:

|  | Rates    | Fringes |
|--|----------|---------|
| OPERATOR: Power Equipment<br>(Steel Erection)          |          |         |
| Compressor, welder and<br>forklift.....                | \$ 33.90 | 24.60   |
| Crane operator, main boom<br>& jib 120' or longer..... | \$ 40.37 | 24.60   |
| Crane operator, main boom<br>& jib 140' or longer..... | \$ 40.67 | 24.60   |
| Crane operator, main boom<br>& jib 220' or longer..... | \$ 41.26 | 24.60   |
| Mechanic with truck and<br>tools.....                  | \$ 39.50 | 24.60   |
| Oiler and fireman.....                                 | \$ 32.36 | 24.60   |
| Regular operator.....                                  | \$ 37.72 | 24.60   |

-----  
 ENGI0324-008 10/01/2020

ALCONA, ALGER, ALLEGAN, ALPENA, ANTRIM, ARENAC, BARAGA, BARRY, BAY, BENZIE, BERRIEN, BRANCH, CALHOUN, CASS, CHARLEVOIX, CHEBOYGAN, CHIPPEWA, CLARE, CLINTON, CRAWFORD, DELTA, DICKINSON, EATON, EMMET, GENESEE, GLADWIN, GOGEBIC, GRAND TRAVERSE, GRATIOT, HILLSDALE, HOUGHTON, HURON, INGHAM, IONIA, IOSCO, IRON, ISABELLA, JACKSON, KALAMAZOO, KALKASKA, KENT, KEWEENAW, LAKE, LAPEER, LEELANAU, LENAWEE, LIVINGSTON, LUCE, MACKINAC, MACOMB, MANISTEE, MARQUETTE, MASON, MECOSTA, MENOMINEE, MIDLAND, MISSAUKEE, MONTCALM, MONTMORENCY, MONROE, MUSKEGON, NEWAYGO, OAKLAND, OCEANA, OGEMAW, ONTONAGON, OSCEOLA, OSCODA, OTSEGO, OTTAWA, PRESQUE ISLE, ROSCOMMON, SAGINAW, ST.

CLARE, ST. JOSEPH, SANILAC, SCHOOLCRAFT, SHIAWASSEE, TUSCOLA,  
 VAN BUREN, WASHTENAW, WAYNE AND WEXFORD COUNTIES

|   | Rates    | Fringes |
|---|----------|---------|
| OPERATOR: Power Equipment<br>(Sewer Relining) |          |         |
| GROUP 1.....                                  | \$ 34.62 | 13.92   |
| GROUP 2.....                                  | \$ 32.83 | 13.92   |

SEWER RELINING CLASSIFICATIONS

GROUP 1: Operation of audio-visual closed circuit TV system, including remote in-ground cutter and other equipment used in connection with the CCTV system

GROUP 2: Operation of hot water heaters and circulation systems, water jettors and vacuum and mechanical debris removal systems

-----  
 ENGI0325-012 05/01/2021

|  | Rates    | Fringes |
|--|----------|---------|
| Power equipment operators -<br>gas distribution and duct<br>installation work: |          |         |
| GROUP 1.....   | \$ 33.48 | 24.85   |
| GROUP 2.....   | \$ 31.45 | 24.85   |
| GROUP 3.....   | \$ 30.35 | 24.85   |

SCOPE OF WORK: The construction, installation, treating and reconditioning of pipelines transporting gas vapors within cities, towns, subdivisions, suburban areas, or within private property boundaries, up to and including private meter settings of private industrial, governmental or other premises, more commonly referred to as "distribution work," starting from the first metering station, connection, similar or related facility, of the main or cross country pipeline and including duct installation.

Group 1: Backhoe, crane, grader, mechanic, dozer (D-6 equivalent or larger), side boom (D-4 equivalent or larger), trencher(except service), endloader (2 yd. capacity or greater).

GROUP 2: Dozer (less than D-6 equivalent), endloader (under 2 yd. capacity), side boom (under D-4 capacity),

backfiller, pumps (1 or 2 of 6-inch discharge or greater), boom truck (with powered boom), tractor (wheel type other than backhoe or front endloader). Tamper (self-propelled), boom truck (with non-powered boom), concrete saw (20 hp or larger), pumps (2 to 4 under 6-inch discharge), compressor (2 or more or when one is used continuously into the second day) and trencher(service).

GROUP 3: Oiler, hydraulic pipe pushing machine, grease person and hydrostatic testing operator.

-----  
 IRON0008-007 06/01/2020

ALGER, BARAGA, CHIPPEWA, DELTA, DICKINSON, GOGEBIC, HOUGHTON, IRON, KEWEENAW, LUCE, MACKINAC MARQUETTE, MENOMINEE, ONTONAGON AND SCHOOLCRAFT COUNTIES:

|   | Rates    | Fringes |
|---|----------|---------|
| Ironworker - pre-engineered metal building erector..... | \$ 23.70 | 6.95    |
| IRONWORKER  |          |         |
| General contracts                                       |          |         |
| \$10,000,000 or greater.....                            | \$ 34.99 | 27.12   |
| General contracts less than \$10,000,000.....           | \$ 34.99 | 27.12   |

Paid Holidays: New Year's Day, Memorial Day, July 4th, Labor Day, Thanksgiving Day & Christmas Day.

-----  
 IRON0025-002 06/01/2019

ALCONA, ALPENA, ARENAC, BAY, CHEBOYGAN, CLARE, CLINTON, CRAWFORD, GENESEE, GLADWIN, GRATIOT, HURON, INGHAM, IOSCO, ISABELLA, JACKSON, LAPEER, LIVINGSTON, MACOMB, MIDLAND, MONTMORENCY, OAKLAND, OGEMAW, OSCODA, OTSEGO, PRESQUE ISLE, ROSCOMMON, SAGINAW, SANILAC, SHIAWASSEE, ST. CLAIR, TUSCOLA, WASHTENAW AND WAYNE COUNTIES:

|   | Rates | Fringes |
|---|-------|---------|
| Ironworker - pre-engineered metal building erector                    |       |         |
| Alcona, Alpena, Arenac, Cheboygan, Clare, Clinton, Crawford, Gladwin, |       |         |

|  |          |       |
|--|----------|-------|
| Gratiot, Huron, Ingham,<br>Iosco, Isabella, Jackson,<br>Lapeer, Livingston (west<br>of Burkhardt Road),<br>Montmorency, Ogemaw,<br>Oscoda, Otsego, Presque<br>Isle, Roscommon, Sanilac,<br>Shiawassee, Tuscola &<br>Washtenaw (west of U.S. 23)... | \$ 24.26 | 22.11 |
| Bay, Genesee, Lapeer,<br>Livingston (east of<br>Burkhardt Road), Macomb,<br>Midland, Oakland, Saginaw,<br>St. Clair, The University<br>of Michigan, Washtenaw<br>(east of U.S. 23) & Wayne...  | \$ 25.48 | 23.11 |
| IRONWORKER   |          |       |
| Ornamental and Structural...   | \$ 36.77 | 29.03 |
| Reinforcing.....   | \$ 30.98 | 27.99 |

-----  
IRON0055-005 07/01/2020

LENAWEE AND MONROE COUNTIES:

|  | Rates    | Fringes |
|--|----------|---------|
| IRONWORKER                             |          |         |
| Pre-engineered metal<br>buildings..... | \$ 23.59 | 19.35   |
| All other work.....                    | \$ 31.00 | 25.60   |

-----  
IRON0292-003 06/01/2020

BERRIEN AND CASS COUNTIES:

|   | Rates    | Fringes |
|---|----------|---------|
| IRONWORKER (Including<br>pre-engineered metal building<br>erector)..... | \$ 31.75 | 22.84   |

-----  
IRON0340-001 06/19/2017

ALLEGAN, ANTRIM, BARRY, BENZIE, BRANCH, CALHOUN, CHARLEVOIX,  
EATON, EMMET, GRAND TRAVERSE, HILLSDALE, IONIA, KALAMAZOO,  
KALKASKA, KENT, LAKE, LEELANAU, MANISTEE, MASON, MECOSTA,  
MISSAUKEE, MONTCALM, MUSKEGON, NEWAYGO, OCEANA, OSCEOLA,  
OTTAWA, ST. JOSEPH, VAN BUREN AND WEXFORD COUNTIES:

|   | Rates    | Fringes |
|---|----------|---------|
| IRONWORKER (Including pre-engineered metal building erector)..... | \$ 24.43 | 24.67   |

---

LABO0005-006 10/01/2020

|  | Rates    | Fringes |
|--|----------|---------|
| Laborers - hazardous waste abatement: (ALCONA, ALPENA, ANTRIM, BENZIE, CHARLEVOIX, CHEBOYGAN, CRAWFORD, EMMET, GRAND TRAVERSE, IOSCO, KALKASKA, LEELANAU, MISSAUKEE, MONTMORENCY, OSCODA, OTSEGO, PRESQUE ISLE AND WEXFORD COUNTIES - Zone 10) |          |         |
| Levels A, B or C.....  | \$ 17.45 | 12.75   |
| class b.....   | \$ 18.64 | 12.90   |
| Work performed in conjunction with site preparation not requiring the use of personal protective equipment;  |          |         |
| Also, Level D.....   | \$ 16.45 | 12.75   |
| class a.....   | \$ 17.64 | 12.90   |
| Zone 10  |          |         |
| Laborers - hazardous waste abatement: (ALGER, BARAGA, CHIPPEWA, DELTA, DICKINSON, GOGEBIC, HOUGHTON, IRON, KEWEENAW, LUCE, MACKINAC, MARQUETTE, MENOMINEE, ONTONAGON AND SCHOOLCRAFT COUNTIES - Zone 11)                                       |          |         |
| Levels A, B or C.....  | \$ 23.58 | 12.90   |
| Work performed in conjunction with site preparation not requiring the use of personal protective equipment;  |          |         |
| Also, Level D.....   | \$ 22.58 | 12.90   |
| Laborers - hazardous waste abatement: (ALLEGAN, BARRY, BERRIEN, BRANCH, CALHOUN, CASS, IONIA COUNTY (except the city of Portland);   |          |         |

KALAMAZOO, KENT, LAKE,  
 MANISTEE, MASON, MECOSTA,  
 MONTCALM, MUSKEGON, NEWAYGO,  
 OCEANA, OSCEOLA, OTTAWA, ST.  
 JOSEPH AND VAN BUREN COUNTIES

- Zone 9)

Levels A, B or C.....\$ 21.80 12.90  
 Work performed in  
 conjunction with site  
 preparation not requiring  
 the use of personal  
 protective equipment;

Also, Level D.....\$ 20.80 12.90

Laborers - hazardous waste  
 abatement: (ARENAC, BAY,  
 CLARE, GLADWIN, GRATIOT,  
 HURON, ISABELLA, MIDLAND,  
 OGEMAW, ROSCOMMON, SAGINAW  
 AND TUSCOLA COUNTIES - Zone 8)

Levels A, B or C.....\$ 21.39 12.90  
 Work performed in  
 conjunction with site  
 preparation not requiring  
 the use of personal  
 protective equipment;

Also, Level D.....\$ 20.80 12.90

Laborers - hazardous waste  
 abatement: (CLINTON, EATON  
 AND INGHAM COUNTIES; IONIA  
 COUNTY (City of Portland);  
 LIVINGSTON COUNTY (west of  
 Oak Grove Rd., including the  
 City of Howell) - Zone 6)

Levels A, B or C.....\$ 25.64 12.90  
 Work performed in  
 conjunction with site  
 preparation not requiring  
 the use of personal  
 protective equipment;

Also, Level D.....\$ 24.64 12.90

Laborers - hazardous waste  
 abatement: (GENESEE, LAPEER  
 AND SHIAWASSEE COUNTIES -  
 Zone 7)

Levels A, B or C.....\$ 24.20 13.80  
 Work performed in  
 conjunction with site  
 preparation not requiring



|   |       |
|---|-------|
| the use of personal<br>protective equipment;<br>Also, Level D.....\$ 23.20  | 13.80 |
| Laborers - hazardous waste<br>abatement: (HILLSDALE,<br>JACKSON AND LENAWEE COUNTIES<br>- Zone 4)   |       |
| Levels A, B or C.....\$ 25.17   | 12.90 |
| Work performed in<br>conjunction with site<br>preparation not requiring<br>the use of personal<br>protective equipment;   |       |
| Also, Level D.....\$ 24.17  | 12.90 |
| Laborers - hazardous waste<br>abatement: (LIVINGSTON COUNTY<br>(east of Oak Grove Rd. and<br>south of M-59, excluding the<br>city of Howell); AND<br>WASHTENAW COUNTY - Zone 3) |       |
| Levels A, B or C.....\$ 29.93   | 14.20 |
| Work performed in<br>conjunction with site<br>preparation not requiring<br>the use of personal<br>protective equipment;   |       |
| Also, Level D.....\$ 28.93  | 14.20 |
| Laborers - hazardous waste<br>abatement: (MACOMB AND WAYNE<br>COUNTIES - Zone 1)  |       |
| Levels A, B or C.....\$ 29.93   | 16.90 |
| Work performed in<br>conjunction with site<br>preparation not requiring<br>the use of personal<br>protective equipment;   |       |
| Also, Level D.....\$ 28.93  | 16.90 |
| Laborers - hazardous waste<br>abatement: (MONROE COUNTY -<br>Zone 4)  |       |
| Levels A, B or C.....\$ 31.75   | 14.90 |
| Work performed in<br>conjunction with site<br>preparation not requiring<br>the use of personal<br>protective equipment;   |       |
| Also, Level D.....\$ 31.75  | 14.90 |
| Laborers - hazardous waste  |       |

abatement: (OAKLAND COUNTY  
 and the Northeast portion of  
 LIVINGSTON COUNTY bordered by  
 Oak Grove Road on the West  
 and M-59 on the South - Zone  
 2)

|   |          |       |
|---|----------|-------|
| Level A, B, C.....  | \$ 29.93 | 16.90 |
| Work performed in<br>conjunction with site<br>preparation not requiring<br>the use of personal<br>protective equipment; |          |       |
| Also, Level D.....  | \$ 28.93 | 16.90 |

Laborers - hazardous waste  
 abatement: (SANILAC AND ST.  
 CLAIR COUNTIES - Zone 5)

|   |          |       |
|---|----------|-------|
| Levels A, B or C.....   | \$ 25.75 | 16.35 |
| Work performed in<br>conjunction with site<br>preparation not requiring<br>the use of personal<br>protective equipment; |          |       |
| Also, Level D.....  | \$ 24.75 | 16.35 |

-----  
 LABO0259-001 09/01/2018

AREA 1: MACOMB, OAKLAND AND WAYNE COUNTIES  
 AREA 2: ALCONA, ALGER, ALLEGAN, ALPENA, ANTRIM, ARENAC, BARAGA,  
 BARRY, BAY, BENZIE, BERRIEN, BRANCH, CALHOUN, CASS, CHARLEVOIX,  
 CHEBOYGAN, CHIPPEWA, CLARE, CLINTON, CRAWFORD, DELTA,  
 DICKINSON, EATON, EMMET, GENESEE, GLADWIN, GOGEBIC, GRAND  
 TRAVERSE, GRATIOT, HILLSDALE, HOUGHTON, HURON, INGHAM, IONIA,  
 IOSCO, IRON, ISABELLA, JACKSON, KALAMAZOO, KALKASKA, KENT,  
 KEWEENAW, LAKE, LAPEER, LEELANAU, LENAWEE, LIVINGSTON, LUCE,  
 MACKINAC, MANISTEE, MARQUETTE, MASON, MECOSTA, MENOMINEE,  
 MIDLAND, MISSAUKEE, MONROE, MONTCALM, MONTMORENCY, MUSKEGON,  
 NEWAYGO, OCEANA, OGEMAW, ONTONAGON, OSCEOLA, OSCODA, OTSEGO,  
 OTTAWA, PRESQUE ISLE, ROSCOMMON, SAGINAW, ST. CLARE, ST.  
 JOSEPH, SANILAC, SCHOOLCRAFT, SHIAWASSEE, TUSCOLA, VAN BUREN,  
 WASHTENAW AND WEXFORD COUNTIES

|  | Rates    | Fringes |
|--|----------|---------|
| Laborers - tunnel, shaft and<br>caisson: |          |         |
| AREA 1                                   |          |         |
| GROUP 1.....                             | \$ 22.57 | 16.80   |
| GROUP 2.....                             | \$ 22.68 | 16.80   |

|              |          |       |
|--------------|----------|-------|
| GROUP 3..... | \$ 22.74 | 16.80 |
| GROUP 4..... | \$ 22.92 | 16.80 |
| GROUP 5..... | \$ 23.17 | 16.80 |
| GROUP 6..... | \$ 23.50 | 16.80 |
| GROUP 7..... | \$ 16.78 | 16.80 |
| AREA 2       |          |       |
| GROUP 1..... | \$ 24.10 | 12.85 |
| GROUP 2..... | \$ 24.19 | 12.85 |
| GROUP 3..... | \$ 24.29 | 12.85 |
| GROUP 4..... | \$ 24.45 | 12.85 |
| GROUP 5..... | \$ 24.71 | 12.85 |
| GROUP 6..... | \$ 25.02 | 12.85 |
| GROUP 7..... | \$ 17.29 | 12.85 |

SCOPE OF WORK: Tunnel, shaft and caisson work of every type and description and all operations incidental thereto, including, but not limited to, shafts and tunnels for sewers, water, subways, transportation, diversion, sewerage, caverns, shelters, aquifers, reservoirs, missile silos and steel sheeting for underground construction.

#### TUNNEL LABORER CLASSIFICATIONS

GROUP 1: Tunnel, shaft and caisson laborer, dump, shanty, hog house tender, testing (on gas) and watchman

GROUP 2: Manhole, headwall, catch basin builder, bricklayer tender, mortar machine and material mixer

GROUP 3: Air tool operator (jackhammer, bush hammer and grinder), first bottom, second bottom, cage tender, car pusher, carrier, concrete, concrete form, concrete repair, cement invert laborer, cement finisher, concrete shoveler, conveyor, floor, gasoline and electric tool operator, gunite, grout operator, welder, heading dinky person, inside lock tender, pea gravel operator, pump, outside lock tender, scaffold, top signal person, switch person, track, tugger, utility person, vibrator, winch operator, pipe jacking, wagon drill and air track operator and concrete saw operator (under 40 h.p.)

GROUP 4: Tunnel, shaft and caisson mucker, bracer, liner plate, long haul dinky driver and well point

GROUP 5: Tunnel, shaft and caisson miner, drill runner, key board operator, power knife operator, reinforced steel or mesh (e.g. wire mesh, steel mats, dowel bars, etc.)

GROUP 6: Dynamite and powder

GROUP 7: Restoration laborer, seeding, sodding, planting, cutting, mulching and top soil grading; and the restoration of property such as replacing mailboxes, wood chips, planter boxes, flagstones, etc.

-----  
LABO0334-001 09/01/2018

|  | Rates    | Fringes |
|--|----------|---------|
| Laborers - open cut:   |          |         |
| ZONE 1 - MACOMB, OAKLAND AND WAYNE COUNTIES:   |          |         |
| GROUP 1.....   | \$ 22.42 | 16.80   |
| GROUP 2.....   | \$ 22.53 | 16.80   |
| GROUP 3.....   | \$ 22.58 | 16.80   |
| GROUP 4.....   | \$ 22.66 | 16.80   |
| GROUP 5.....   | \$ 22.72 | 16.80   |
| GROUP 6.....   | \$ 20.17 | 16.80   |
| GROUP 7.....   | \$ 16.79 | 16.80   |
| ZONE 2 - LIVINGSTON COUNTY (east of M-151 (Oak Grove Rd.)); MONROE AND WASHTENAW COUNTIES:   |          |         |
| GROUP 1.....   | \$ 23.75 | 12.85   |
| GROUP 2.....   | \$ 23.86 | 12.85   |
| GROUP 3.....   | \$ 23.98 | 12.85   |
| GROUP 4.....   | \$ 24.05 | 12.85   |
| GROUP 5.....   | \$ 24.20 | 12.85   |
| GROUP 6.....   | \$ 21.50 | 12.85   |
| GROUP 7.....   | \$ 18.14 | 12.85   |
| ZONE 3 - CLINTON, EATON, GENESEE, HILLSDALE AND INGHAM COUNTIES; IONIA COUNTY (City of Portland); JACKSON, LAPEER AND LENAWEE COUNTIES; LIVINGSTON COUNTY (west of M-151 Oak Grove Rd.); SANILAC, ST. CLAIR AND SHIAWASSEE COUNTIES: |          |         |
| GROUP 1.....   | \$ 21.94 | 12.85   |
| GROUP 2.....   | \$ 22.08 | 12.85   |
| GROUP 3.....   | \$ 22.20 | 12.85   |
| GROUP 4.....   | \$ 22.25 | 12.85   |
| GROUP 5.....   | \$ 22.39 | 12.85   |
| GROUP 6.....   | \$ 19.69 | 12.85   |

|  |          |       |
|--|----------|-------|
| GROUP 7.....   | \$ 16.84 | 12.85 |
| ZONE 4 - ALCONA, ALLEGAN,<br>ALPENA, ANTRIM, ARENAC,<br>BARRY, BAY, BENZIE,<br>BERRIEN, BRANCH,<br>CALHOUN, CASS, CHARLEVOIX,<br>CHEBOYGAN, CLARE,<br>CRAWFORD, EMMET,<br>GLADWIN, GRAND TRAVERSE,<br>GRATIOT AND HURON<br>COUNTIES; IONIA COUNTY<br>(EXCEPT THE CITY OF<br>PORTLAND); IOSCO,<br>ISABELLA, KALAMAZOO,<br>KALKASKA, KENT,<br>LAKE, LEELANAU, MANISTEE,<br>MASON, MECOSTA, MIDLAND,<br>MISSAUKEE, MONTCALM,<br>MONTMORENCY, MUSKEGON,<br>NEWAYGO, OCEANA, OGEMAW,<br>OSCEOLA, OSCODA, OTSEGO,<br>OTTAWA, PRESQUE ISLE,<br>ROSCOMMON, SAGINAW, ST.<br>JOSEPH, TUSCOLA, VAN BUREN<br>AND WEXFORD COUNTIES: |          |       |
| GROUP 1.....   | \$ 20.97 | 12.85 |
| GROUP 2.....   | \$ 21.10 | 12.85 |
| GROUP 3.....   | \$ 21.21 | 12.85 |
| GROUP 4.....   | \$ 21.28 | 12.85 |
| GROUP 5.....   | \$ 21.40 | 12.85 |
| GROUP 6.....   | \$ 18.62 | 12.85 |
| GROUP 7.....   | \$ 16.96 | 12.85 |
| ZONE 5 - ALGER, BARAGA,<br>CHIPPEWA, DELTA,<br>DICKINSON, GOGEBIC,<br>HOUGHTON, IRON,<br>KEWEENAW, LUCE, MACKINAC,<br>MARQUETTE, MENOMINEE,<br>ONTONAGON AND SCHOOLCRAFT<br>COUNTIES:  |          |       |
| GROUP 1.....   | \$ 21.19 | 12.85 |
| GROUP 2.....   | \$ 21.33 | 12.85 |
| GROUP 3.....   | \$ 21.46 | 12.85 |
| GROUP 4.....   | \$ 21.51 | 12.85 |
| GROUP 5.....   | \$ 21.56 | 12.85 |
| GROUP 6.....   | \$ 18.94 | 12.85 |
| GROUP 7.....   | \$ 17.05 | 12.85 |

## SCOPE OF WORK:

Open cut construction work shall be construed to mean work which requires the excavation of earth including industrial, commercial and residential building site excavation and preparation, land balancing, demolition and removal of concrete and underground appurtenances, grading, paving, sewers, utilities and improvements; retention, oxidation, flocculation and irrigation facilities, and also including but not limited to underground piping, conduits, steel sheeting for underground construction, and all work incidental thereto, and general excavation. For all areas except the Upper Peninsula, open cut construction work shall also be construed to mean waterfront work, piers, docks, seawalls, breakwalls, marinas and all incidental work. Open cut construction work shall not include any structural modifications, alterations, additions and repairs to buildings, or highway work, including roads, streets, bridge construction and parking lots or steel erection work and excavation for the building itself and back filling inside of and within 5 ft. of the building and foundations, footings and piers for the building. Open cut construction work shall not include any work covered under Tunnel, Shaft and Caisson work.

## OPEN CUT LABORER CLASSIFICATIONS

GROUP 1: Construction laborer

GROUP 2: Mortar and material mixer, concrete form person, signal person, well point person, manhole, headwall and catch basin builder, headwall, seawall, breakwall and dock builder

GROUP 3: Air, gasoline and electric tool operator, vibrator operator, driller, pump person, tar kettle operator, bracer, rodder, reinforced steel or mesh person (e.g., wire mesh, steel mats, dowel bars, etc.), welder, pipe jacking and boring person, wagon drill and air track operator and concrete saw operator (under 40 h.p.), windlass and tugger person and directional boring person

GROUP 4: Trench or excavating grade person

GROUP 5: Pipe layer (including crock, metal pipe, multi-plate or other conduits)

GROUP 6: Grouting man, audio-visual television operations and

all other operations in connection with closed circuit television inspection, pipe cleaning and pipe relining work and the installation and repair of water service pipe and appurtenances

GROUP 7: Restoration laborer, seeding, sodding, planting, cutting, mulching and top soil grading; and the restoration of property such as replacing mailboxes, wood chips, planter boxes, flagstones, etc.

-----  
LABO0465-001 06/01/2020

LABORER: Highway, Bridge and Airport Construction

AREA 1: GENESEE, MACOMB, MONROE, OAKLAND, WASHTENAW AND WAYNE COUNTIES

AREA 2: ALLEGAN, BARRY, BAY, BERRIEN, BRANCH, CALHOUN, CASS, CLINTON, EATON, GRATIOT, HILLSDALE, HURON, INGHAM, JACKSON, KALAMAZOO, LAPEER, LENAWEE, LIVINGSTON, MIDLAND, MUSKEGON, SAGINAW, SANILAC, SHIAWASSEE, ST. CLAIR, ST. JOSEPH, TUSCOLA AND VAN BUREN COUNTIES

AREA 3: ALCONA, ALPENA, ANTRIM, ARENAC, BENZIE, CHARLEVOIX, CHEBOYGAN, CLARE, CRAWFORD, EMMET, GLADWIN, GRAND TRAVERSE, IONIA, IOSCO, ISABELLA, KALKASKA, KENT, LAKE, LEELANAU, MANISTEE, MASON, MECOSTA, MISSAUKEE, MONTCALM, MONTMORENCY, NEWAYGO, OCEANA, OGEMAW, OSCEOLA, OSCODA, OTSEGO, OTTAWA, PRESQUE ISLE, ROSCOMMON AND WEXFORD COUNTIES

AREA 4: ALGER, BARAGA, CHIPPEWA, DELTA, DICKINSON, GOGEBIC, HOUGHTON, IRON, KEWEENAW, LUCE, MACKINAC, MARQUETTE, MENOMINEE, ONTONAGON AND SCHOOLCRAFT COUNTIES

|                  | Rates    | Fringes |
|------------------|----------|---------|
| LABORER (AREA 1) |          |         |
| GROUP 1.....     | \$ 26.22 | 12.90   |
| GROUP 2.....     | \$ 26.43 | 12.90   |
| GROUP 3.....     | \$ 26.72 | 12.90   |
| GROUP 4.....     | \$ 27.16 | 12.90   |
| GROUP 5.....     | \$ 26.78 | 12.90   |
| GROUP 6.....     | \$ 27.21 | 12.90   |
| LABORER (AREA 2) |          |         |
| GROUP 1.....     | \$ 26.92 | 12.90   |
| GROUP 2.....     | \$ 27.12 | 12.90   |
| GROUP 3.....     | \$ 27.36 | 12.90   |

|                  |          |       |
|------------------|----------|-------|
| GROUP 4.....     | \$ 27.71 | 12.90 |
| GROUP 5.....     | \$ 27.58 | 12.90 |
| GROUP 6.....     | \$ 27.92 | 12.90 |
| LABORER (AREA 3) |          |       |
| GROUP 1.....     | \$ 26.22 | 12.90 |
| GROUP 2.....     | \$ 26.43 | 12.90 |
| GROUP 3.....     | \$ 26.72 | 12.90 |
| GROUP 4.....     | \$ 27.16 | 12.90 |
| GROUP 5.....     | \$ 26.78 | 12.90 |
| GROUP 6.....     | \$ 27.21 | 12.90 |
| LABORER (AREA 4) |          |       |
| GROUP 1.....     | \$ 26.22 | 12.90 |
| GROUP 2.....     | \$ 26.43 | 12.90 |
| GROUP 3.....     | \$ 26.72 | 12.90 |
| GROUP 4.....     | \$ 27.16 | 12.90 |
| GROUP 5.....     | \$ 26.78 | 12.90 |
| GROUP 6.....     | \$ 27.21 | 12.90 |

#### LABORER CLASSIFICATIONS

GROUP 1: Asphalt shoveler or loader; asphalt plant misc.; burlap person; yard person; dumper (wagon, truck, etc.); joint filling laborer; miscellaneous laborer; unskilled laborer; sprinkler laborer; form setting laborer; form stripper; pavement reinforcing; handling and placing (e.g., wire mesh, steel mats, dowel bars); mason's tender or bricklayer's tender on manholes; manhole builder; headwalls, etc.; waterproofing, (other than buildings) seal coating and slurry mix, shoring, underpinning; pressure grouting; bridge pin and hanger removal; material recycling laborer; horizontal paver laborer (brick, concrete, clay, stone and asphalt); ground stabilization and modification laborer; grouting; waterblasting; top person; railroad track and trestle laborer; carpenters' tender; guard rail builders' tender; earth retention barrier and wall and M.S.E. wall installer's tender; highway and median installer's tender (including sound, retaining, and crash barriers); fence erector's tender; asphalt raker tender; sign installer; remote control operated equipment.

GROUP 2: Mixer operator (less than 5 sacks); air or electric tool operator (jackhammer, etc.); spreader; boxperson (asphalt, stone, gravel); concrete paddler; power chain saw operator; paving batch truck dumper; tunnel mucker (highway work only); concrete saw (under 40 h.p.) and dry pack machine; roto-mill grounds person.

GROUP 3: Tunnel miner (highway work only); finishers tenders;



guard rail builders; highway and median barrier installer; earth retention barrier and wall and M.S.E. wall installer's (including sound, retaining and crash barriers); fence erector; bottom person; powder person; wagon drill and air track operator; diamond and core drills; grade checker; certified welders; curb and side rail setter's tender.

GROUP 4: Asphalt raker

GROUP 5: Pipe layers, oxy-gun

GROUP 6: Line-form setter for curb or pavement; asphalt screed checker/screw man on asphalt paving machines.

-----  
 \* LAB01076-005 04/01/2021

MICHIGAN STATEWIDE

|                             | Rates    | Fringes |
|-----------------------------|----------|---------|
| LABORER (DISTRIBUTION WORK) |          |         |
| Zone 1.....                 | \$ 23.92 | 12.95   |
| Zone 2.....                 | \$ 22.22 | 12.95   |
| Zone 3.....                 | \$ 20.35 | 12.95   |
| Zone 4.....                 | \$ 19.77 | 12.95   |
| Zone 5.....                 | \$ 19.75 | 12.95   |

DISTRIBUTION WORK - The construction, installation, treating and reconditioning of distribution pipelines transporting coal, oil, gas or other similar materials, vapors or liquids, including pipelines within private property boundaries, up to and including the meter settings on residential, commercial, industrial, institutional, private and public structures. All work covering pumping stations and tank farms not covered by the Building Trades Agreement. Other distribution lines with the exception of sewer, water and cable television are included.

Underground Duct Layer Pay: \$.40 per hour above the base pay rate.

- Zone 1 - Macomb, Oakland and Wayne
- Zone 2 - Monroe and Washtenaw
- Zone 3 - Bay, Genesee, Lapeer, Midland, Saginaw, Sanilac, Shiawassee and St. Clair
- Zone 4 - Alger, Baraga, Chippewa, Delta, Dickinson, Gogebic, Houghton, Iron, Keweenaw, Luce, Mackinac, Marquette,

Menominee, Ontonagon and Schoolcraft  
Zone 5 - Remaining Counties in Michigan

-----  
PAIN0022-002 07/01/2008

HILLSDALE, JACKSON AND LENAWEE COUNTIES; LIVINGSTON COUNTY (east of the eastern city limits of Howell, not including the city of Howell, north to the Genesee County line and south to the Washtenaw County line); MACOMB, MONROE, OAKLAND, WASHTENAW AND WAYNE COUNTIES:

|              | Rates    | Fringes |
|--------------|----------|---------|
| PAINTER..... | \$ 25.06 | 14.75   |

FOOTNOTES: For all spray work and journeyman rigging for spray work, also blowing off, \$0.80 per hour additional (applies only to workers doing rigging for spray work on off the floor work. Does not include setting up or moving rigging on floor surfaces, nor does it apply to workers engaged in covering up or tending spray equipment. For all sandblasting and spray work performed on highway bridges, overpasses, tanks or steel, \$0.80 per hour additional. For all brushing, cleaning and other preparatory work (other than spraying or steeplejack work) at scaffold heights of fifty (50) feet from the ground or higher, \$0.50 per hour additional. For all preparatorial work and painting performed on open steel under forty (40) feet when no scaffolding is involved, \$0.50 per hour additional. For all swing stage work-window jacks and window belts-exterior and interior, \$0.50 per hour additional. For all spray work and sandblaster work to a scaffold height of forty (40) feet above the floor level, \$0.80 per hour additional. For all preparatorial work and painting on all highway bridges or overpasses up to forty (40) feet in height, \$0.50 per hour additional. For all steeplejack work performed where the elevation is forty (40) feet or more, \$1.25 per hour additional.

-----  
PAIN0312-001 06/01/2018

EXCLUDES: ALLEGAN COUNTY (Townships of Dorr, Fillmore, Heath, Hopkins, Laketown, Leighton, Manlius, Monterey, Overisel, Salem, Saugatuck and Wayland); INCLUDES: Barry, Berrien, Branch, Calhoun, Cass, Hillsdale, Kalamazoo, St. Joseph, Van Buren

|   | Rates    | Fringes |
|---|----------|---------|
| PAINTER                                 |          |         |
| Brush and roller.....                   | \$ 23.74 | 13.35   |
| Spray, Sandblast, Sign<br>Painting..... | \$ 24.94 | 13.35   |

-----  
PAIN0845-003 05/10/2018

CLINTON COUNTY; EATON COUNTY (does not include the townships of Bellevue and Olivet); INGHAM COUNTY; IONIA COUNTY (east of Hwy. M 66); LIVINGSTON COUNTY (west of the eastern city limits of Howell, including the city of Howell, north to the Genesee County line and south to the Washtenaw County line); AND SHIAWASSEE COUNTY (Townships of Bennington, Laingsbury and Perry):

|              | Rates    | Fringes |
|--------------|----------|---------|
| PAINTER..... | \$ 25.49 | 13.74   |

-----  
PAIN0845-015 05/10/2018

MUSKEGON COUNTY; NEWAYGO COUNTY (except the Townships of Barton, Big Prairie, Brooks, Croton, Ensley, Everett, Goodwell, Grant, Home, Monroe, Norwich and Wilcox); OCEANA COUNTY; OTTAWA COUNTY (except the townships of Allendale, Blendone, Chester, Georgetown, Holland, Jamestown, Olive, Park, Polkton, Port Sheldon, Tallmadge, Wright and Zeeland):

|              | Rates    | Fringes |
|--------------|----------|---------|
| PAINTER..... | \$ 25.49 | 13.74   |

-----  
PAIN0845-018 05/10/2018

ALLEGAN COUNTY (Townships of Dorr, Fillmore, Heath, Hopkins, Laketown, Leighton, Manlius, Monterey, Overisel, Salem, Saugatuck and Wayland); IONIA COUNTY (west of Hwy. M-66); KENT, MECOSTA AND MONTCALM COUNTIES; NEWAYGO COUNTY (Townships of Barton, Big Prairie, Brooks, Croton, Ensley, Everett, Goodwell, Grant, Home, Monroe, Norwich and Wilcox); OSCEOLA COUNTY (south of Hwy. #10); OTTAWA COUNTY (Townships of Allendale, Blendone, Chester, Georgetown, Holland, Jamestown, Olive, Park, Polkton, Port Sheldon, Tallmadge, Wright and Zeeland):

|              | Rates    | Fringes |
|--------------|----------|---------|
| PAINTER..... | \$ 25.49 | 13.74   |

FOOTNOTES: Lead abatement work: \$1.00 per hour additional.

-----  
PAIN1011-003 06/02/2019

ALGER, BARAGA, CHIPPEWA, DELTA, DICKINSON, GOGEBIC, HOUGHTON,  
IRON, KEWEENAW, LUCE, MACKINAC, MARQUETTE, MENOMINEE, ONTONAGON  
AND SCHOOLCRAFT COUNTIES:

|              | Rates    | Fringes |
|--------------|----------|---------|
| PAINTER..... | \$ 25.76 | 13.33   |

FOOTNOTES: High pay (bridges, overpasses, watertower): 30 to  
80 ft.: \$.65 per hour additional. 80 ft. and over: \$1.30  
per hour additional.

-----  
PAIN1474-002 06/01/2010

HURON COUNTY; LAPEER COUNTY (east of Hwy. M-53); ST. CLAIR,  
SANILAC AND TUSCOLA COUNTIES:

|              | Rates    | Fringes |
|--------------|----------|---------|
| PAINTER..... | \$ 23.79 | 12.02   |

FOOTNOTES: Lead abatement work: \$1.00 per hour additional.  
Work with any hazardous material: \$1.00 per hour  
additional. Sandblasting, steam cleaning and acid cleaning:  
\$1.00 per hour additional. Ladder work at or above 40 ft.,  
scaffold work at or above 40 ft., swing stage, boatswain  
chair, window jacks and all work performed over a falling  
height of 40 ft.: \$1.00 per hour additional. Spray gun  
work, pick pullers and those handling needles, blowing off  
by air pressure, and any person rigging (setting up and  
moving off the ground): \$1.00 per hour additional.  
Steeplejack, tanks, gas holders, stacks, flag poles, radio  
towers and beacons, power line towers, bridges, etc.: \$1.00  
per hour additional, paid from the ground up.

-----  
PAIN1803-003 06/01/2019

ALCONA, ALPENA, ANTRIM, ARENAC, BAY, BENZIE, CHARLEVOIX,  
CHEBOYGAN, CLARE, CRAWFORD, EMMET, GLADWIN, GRAND TRAVERSE,

GRATIOT, IOSCO, ISABELLA, KALKASKA, LAKE, LEELANAU, MANISTEE, MASON, MIDLAND, MISSAUKEE, MONTMORENCY AND OGEMAW COUNTIES; OSCEOLA COUNTY (north of Hwy. #10); OSCODA, OTSEGO, PRESQUE ISLE, ROSCOMMON, SAGINAW AND WEXFORD COUNTIES:

|  | Rates    | Fringes |
|--|----------|---------|
| PAINTER  |          |         |
| Work performed on water, bridges over water or moving traffic, radio and powerline towers, elevated tanks, steeples, smoke stacks over 40 ft. of falling heights, recovery of lead-based paints and any work associated with industrial plants, except maintenance of industrial plants..... | \$ 25.39 | 14.68   |
| All other work, including maintenance of industrial plant.....   | \$ 25.39 | 14.68   |

FOOTNOTES: Spray painting, sandblasting, blowdown associated with spraying and blasting, water blasting and work involving a swing stage, boatswain chair or spider: \$1.00 per hour additional. All work performed inside tanks, vessels, tank trailers, railroad cars, sewers, smoke stacks, boilers or other spaces having limited egress not including buildings, opentop tanks, pits, etc.: \$1.25 per hour additional.

-----  
 PLAS0514-001 06/01/2018

ZONE 1: GENESEE, LIVINGSTON, MACOMB, MONROE, OAKLAND, SAGINAW, WASHTENAW AND WAYNE COUNTIES

ZONE 2: ALCONA, ALGER, ALLEGAN, ALPENA, ANTRIM, ARENAC, BARAGA, BARRY, BAY, BENZIE, BERRIEN, BRANCH, CALHOUN, CASS, CHARLEVOIX, CHEBOYGAN, CHIPPEWA, CLARE, CLINTON, CRAWFORD, DELTA, DICKINSON, EATON, EMMET, GLADWIN, GOGEBIC, GRAND TRAVERSE, GRATIOT, HILLSDALE, HOUGHTON, HURON, INGHAM, IONIA, IOSCO, IRON, ISABELLA, JACKSON, KALAMAZOO, KALKASKA, KENT, KEWEENAW, LAKE, LAPEER, LEELANAU, LENAWEE, LUCE, MACKINAC, MANISTEE, MARQUETTE, MASON, MECOSTA, MENOMINEE, MIDLAND, MISSAUKEE,

MONTCALM, MONTMORENCY, MUSKEGON, NEWAYGO, OCEANA, OGEMAW,  
 ONTONAGON, OSCEOLA, OSCODA, OTSEGO, OTTAWA, PRESQUE ISLE,  
 ROSCOMMON, SANILAC, SCHOOLCRAFT, SHIAWASSEE, ST. CLAIR, ST.  
 JOSEPH, TUSCOLA, VAN BUREN AND WEXFORD COUNTIES

|                                | Rates    | Fringes |
|--------------------------------|----------|---------|
| CEMENT MASON/CONCRETE FINISHER |          |         |
| ZONE 1.....                    | \$ 31.47 | 13.81   |
| ZONE 2.....                    | \$ 29.97 | 13.81   |

-----  
 PLUM0190-003 05/01/2015

ALCONA, ALGER, ALLEGAN, ALPENA, ANTRIM, ARENAC, BARAGA, BARRY,  
 BAY, BENZIE, BERRIEN, BRANCH, CALHOUN, CASS, CHARLEVOIX,  
 CHEBOYGAN, CHIPPEWA, CLARE, CLINTON, CRAWFORD, DELTA,  
 DICKINSON, EATON, EMMET, GENESEE, GLADWIN, GOGEBIC, GRAND  
 TRAVERSE, GRATIOT, HILLSDALE, HOUGHTON, HURON, INGHAM, IONIA,  
 IOSCO, IRON, ISABELLA, JACKSON, KALAMAZOO, KALKASKA, KENT,  
 KEWEENAW, LAKE, LAPEER, LEELANAU, LENAWEE, LIVINGSTON, LUCE,  
 MACKINAC, MACOMB, MANISTEE, MARQUETTE, MASON, MECOSTA,  
 MENOMINEE, MIDLAND, MISSAUKEE, MONTCALM, MONTMORENCY, MONROE,  
 MUSKEGON, NEWAYGO, OAKLAND, OCEANA, OGEMAW, ONTONAGON, OSCEOLA,  
 OSCODA, OTSEGO, OTTAWA, PRESQUE ISLE, ROSCOMMON, SAGINAW, ST.  
 CLARE, ST. JOSEPH, SANILAC, SCHOOLCRAFT, SHIAWASSEE, TUSCOLA,  
 VAN BUREN, WASHTENAW, WAYNE AND WEXFORD COUNTIES

|   | Rates    | Fringes |
|---|----------|---------|
| Plumber/Pipefitter - gas<br>distribution pipeline:                    |          |         |
| Welding in conjunction<br>with gas distribution<br>pipeline work..... | \$ 33.03 | 20.19   |
| All other work:.....  | \$ 24.19 | 12.28   |

-----  
 TEAM0007-004 06/01/2020

AREA 1: ALCONA, ALGER, ALLEGAN, ALPENA, ANTRIM, ARENAC, BARAGA,  
 BARRY, BAY, BENZIE, BERRIEN, BRANCH, CALHOUN, CASS, CHARLEVOIX,  
 CHEBOYGAN, CHIPPEWA, CLARE, CLINTON, CRAWFORD, DELTA,  
 DICKINSON, EATON, EMMET, GLADWIN, GOGEBIC, GRAND TRAVERSE,  
 GRATIOT, HILLSDALE, HOUGHTON, HURON, INGHAM, IONIA, IOSCO,  
 IRON, ISABELLA, JACKSON, KALAMAZOO, KALKASKA, KENT, KEWEENAW,  
 LAKE, LAPEER, LEELANAU, LENAWEE, LUCE, MACKINAC, MANISTEE,  
 MARQUETTE, MASON, MECOSTA, MENOMINEE, MIDLAND, MISSAUKEE,  
 MONTCALM, MONTMORENCY, MUSKEGON, NEWAYGO, OCEANA, OGEMAW,  
 ONTONAGON, OSCEOLA, OSCODA, OTSEGO, OTTAWA, PRESQUE ISLE,

ROSCOMMON, SAGINAW, SANILAC, SCHOOLCRAFT, SHIAWASSEE, ST.  
 CLAIR, ST. JOSEPH, TUSCOLA, VAN BUREN AND WEXFORD COUNTIES

AREA 2: GENESEE, LIVINGSTON, MACOMB, MONROE, OAKLAND, WASHTENAW  
 AND WAYNE COUNTIES

|  | Rates     | Fringes   |
|--|-----------|-----------|
| TRUCK DRIVER                                 |           |           |
| AREA 1                                       |           |           |
| Euclids, double bottoms<br>and lowboys.....  | \$ 28.05  | .50 + a+b |
| Trucks under 8 cu. yds.....                  | \$ 27.80  | .50 + a+b |
| Trucks, 8 cu. yds. and<br>over.....          | \$ 27.90  | .50 + a+b |
| AREA 2                                       |           |           |
| Euclids, double bottomms<br>and lowboys..... | \$ 24.895 | .50 + a+b |
| Euclids, double bottoms<br>and lowboys.....  | \$ 28.15  | .50 + a+b |
| Trucks under 8 cu. yds.....                  | \$ 27.90  | .50 + a+b |
| Trucks, 8 cu. yds. and<br>over.....          | \$ 28.00  | .50 + a+b |

Footnote:

- a. \$470.70 per week
- b. \$68.70 daily

-----  
 TEAM0247-004 04/01/2013

AREA 1: ALCONA, ALGER, ALLEGAN, ALPENA, ANTRIM, ARENAC, BARAGA,  
 BARRY, BAY, BENZIE, BERRIEN, BRANCH, CALHOUN, CASS, CHARLEVOIX,  
 CHEBOYGAN, CHIPPEWA, CLARE, CLINTON, CRAWFORD, DELTA,  
 DICKINSON, EATON, EMMET, GLADWIN, GOGEBIC, GRAND TRAVERSE,  
 GRATIOT, HILLSDALE, HOUGHTON, HURON, INGHAM, IONIA, IOSCO,  
 IRON, ISABELLA, JACKSON, KALAMAZOO, KALKASKA, KENT, KEWEENAW,  
 LAKE, LAPEER, LEELANAU, LENAWEE, LUCE, MACKINAC, MANISTEE,  
 MARQUETTE, MASON, MECOSTA, MENOMINEE, MIDLAND, MISSAUKEE,  
 MONTCALM, MONTMORENCY, MUSKEGON, NEWAYGO, OCEANA, OGEMAW,  
 ONTONAGON, OSCEOLA, OSCODA, OTSEGO, OTTAWA, PRESQUE ISLE,  
 ROSCOMMON, SANILAC, SCHOOLCRAFT, SHIAWASSEE, SAGINAW, ST.  
 CLAIR, ST. JOSEPH, TUSCOLA, VAN BUREN AND WEXFORD COUNTIES

AREA 2: GENESEE, LIVINGSTON, MACOMB, MONROE, OAKLAND,  
 WASHTENAW AND WAYNE COUNTIES

|                | Rates    | Fringes |
|----------------|----------|---------|
| Sign Installer |          |         |
| AREA 1         |          |         |
| GROUP 1.....   | \$ 21.78 | 11.83   |
| GROUP 2.....   | \$ 25.27 | 11.8375 |
| AREA 2         |          |         |
| GROUP 1.....   | \$ 22.03 | 11.83   |
| GROUP 2.....   | \$ 25.02 | 11.8375 |

FOOTNOTE:

a. \$132.70 per week, plus \$17.80 per day.

SIGN INSTALLER CLASSIFICATIONS:

GROUP 1: performs all necessary labor and uses all tools required to construct and set concrete forms required in the installation of highway and street signs

GROUP 2: performs all miscellaneous labor, uses all hand and power tools, and operates all other equipment, mobile or otherwise, required for the installation of highway and street signs

-----  
TEAM0247-010 04/01/2018

AREA 1: LAPEER AND SHIAWASSEE COUNTIES

AREA 2: GENESEE, MACOMB, MONROE, OAKLAND, ST. CLAIR, WASHTENAW AND WAYNE COUNTIES

|   | Rates    | Fringes |
|---|----------|---------|
| TRUCK DRIVER (Underground construction) |          |         |
| AREA 1                                  |          |         |
| GROUP 1.....                            | \$ 23.82 | 19.04   |
| GROUP 2.....                            | \$ 23.91 | 19.04   |
| GROUP 3.....                            | \$ 24.12 | 19.04   |
| AREA 2                                  |          |         |
| GROUP 1.....                            | \$ 24.12 | 19.04   |
| GROUP 2.....                            | \$ 24.26 | 19.04   |
| GROUP 3.....                            | \$ 24.45 | 19.04   |

PAID HOLIDAYS: New Year's Day, Memorial Day, Fourth of July, Labor Day, Thanksgiving Day and Christmas Day.



SCOPE OF WORK: Excavation, site preparation, land balancing, grading, sewers, utilities and improvements; also including but not limited to, tunnels, underground piping, retention, oxidation, flocculation facilities, conduits, general excavation and steel sheeting for underground construction. Underground construction work shall not include any structural modifications, alterations, additions and repairs to buildings or highway work, including roads, streets, bridge construction and parking lots or steel erection.

TRUCK DRIVER CLASSIFICATIONS

GROUP 1: Truck driver on all trucks (EXCEPT dump trucks of 8 cubic yards capacity or over, pole trailers, semis, low boys, Euclid, double bottom and fuel trucks)

GROUP 2: Truck driver on dump trucks of 8 cubic yards capacity or over, pole trailers, semis and fuel trucks

GROUP 3: Truck driver on low boy, Euclid and double bottom

-----  
SUMI2002-001 05/01/2002

|  | Rates    | Fringes |
|--|----------|---------|
| Flag Person.....   | \$ 10.10 | 0.00    |
| LINE PROTECTOR (ZONE 1:<br>GENESEE, MACOMB, MONROE,<br>OAKLAND, WASHTENAW AND WAYNE)....                                   | \$ 20.30 | 12.90   |
| LINE PROTECTOR (ZONE 2:<br>STATEWIDE (EXCLUDING GENESEE,<br>MACOMB, MONROE, OAKLAND,<br>WASHTENAW AND WAYNE).....          | \$ 18.02 | 12.90   |
| Pavement Marking Machine<br>(ZONE 1: GENESEE, MACOMB,<br>MONROE, OAKLAND, WASHTENAW<br>AND WAYNE COUNTIES)<br>Group 1..... | \$ 27.07 | 12.90   |
| Pavement Marking Machine<br>(ZONE 1: GENESEE, MACOMB,<br>MONROE, OAKLAND, WASHTENAW<br>AND WAYNE)                          |          |         |

Group 2.....\$ 24.36 12.90

Pavement Marking Machine  
(ZONE 2: STATEWIDE (EXCLUDING  
GENESEEE, MACOMB, MONROE,  
OAKLAND, WASHTENAW AND WAYNE  
COUNTIES)

Group 1.....\$ 24.02 12.90

Pavement Marking Machine  
(ZONE 2: STATEWIDE (EXCLUDING  
GENESEEE, MACOMB, MONROE,  
OAKLAND, WASHTENAW AND WAYNE)

Group 2.....\$ 21.62 12.90

WORK CLASSIFICATIONS:

PAVEMENT MARKER GROUP 1: Drives or operates a truck mounted  
striper, grinder, blaster, groover, or thermoplastic melter  
for the placement or removal of temporary or permanent  
pavement markings or markers.

PAVEMENT MARKER GROUP 2: Performs all functions involved for  
the placement or removal of temporary or permanent pavement  
markings or markers not covered by the classification of  
Pavement Marker Group 1 or Line Protector.

LINE PROTECTOR: Performs all operations for the protection or  
removal of temporary or permanent pavement markings or  
markers in a moving convoy operation not performed by the  
classification of Pavement Marker Group 1. A moving convoy  
operation is comprised of only Pavement Markers Group 1 and  
Line Protectors.

-----  
WELDERS - Receive rate prescribed for craft performing  
operation to which welding is incidental.

=====  
Note: Executive Order (EO) 13706, Establishing Paid Sick Leave  
for Federal Contractors applies to all contracts subject to the  
Davis-Bacon Act for which the contract is awarded (and any  
solicitation was issued) on or after January 1, 2017. If this  
contract is covered by the EO, the contractor must provide  
employees with 1 hour of paid sick leave for every 30 hours  
they work, up to 56 hours of paid sick leave each year.

Employees must be permitted to use paid sick leave for their own illness, injury or other health-related needs, including preventive care; to assist a family member (or person who is like family to the employee) who is ill, injured, or has other health-related needs, including preventive care; or for reasons resulting from, or to assist a family member (or person who is like family to the employee) who is a victim of, domestic violence, sexual assault, or stalking. Additional information on contractor requirements and worker protections under the EO is available at [www.dol.gov/whd/govcontracts](http://www.dol.gov/whd/govcontracts).

Unlisted classifications needed for work not included within the scope of the classifications listed may be added after award only as provided in the labor standards contract clauses (29CFR 5.5 (a) (1) (ii)).

-----

The body of each wage determination lists the classification and wage rates that have been found to be prevailing for the cited type(s) of construction in the area covered by the wage determination. The classifications are listed in alphabetical order of ""identifiers"" that indicate whether the particular rate is a union rate (current union negotiated rate for local), a survey rate (weighted average rate) or a union average rate (weighted union average rate).

#### Union Rate Identifiers

A four letter classification abbreviation identifier enclosed in dotted lines beginning with characters other than ""SU"" or ""UAVG"" denotes that the union classification and rate were prevailing for that classification in the survey. Example: PLUM0198-005 07/01/2014. PLUM is an abbreviation identifier of the union which prevailed in the survey for this classification, which in this example would be Plumbers. 0198 indicates the local union number or district council number where applicable, i.e., Plumbers Local 0198. The next number, 005 in the example, is an internal number used in processing the wage determination. 07/01/2014 is the effective date of the most current negotiated rate, which in this example is July 1, 2014.

Union prevailing wage rates are updated to reflect all rate changes in the collective bargaining agreement (CBA) governing this classification and rate.

## Survey Rate Identifiers

Classifications listed under the ""SU"" identifier indicate that no one rate prevailed for this classification in the survey and the published rate is derived by computing a weighted average rate based on all the rates reported in the survey for that classification. As this weighted average rate includes all rates reported in the survey, it may include both union and non-union rates. Example: SULA2012-007 5/13/2014. SU indicates the rates are survey rates based on a weighted average calculation of rates and are not majority rates. LA indicates the State of Louisiana. 2012 is the year of survey on which these classifications and rates are based. The next number, 007 in the example, is an internal number used in producing the wage determination. 5/13/2014 indicates the survey completion date for the classifications and rates under that identifier.

Survey wage rates are not updated and remain in effect until a new survey is conducted.

## Union Average Rate Identifiers

Classification(s) listed under the UAVG identifier indicate that no single majority rate prevailed for those classifications; however, 100% of the data reported for the classifications was union data. EXAMPLE: UAVG-OH-0010 08/29/2014. UAVG indicates that the rate is a weighted union average rate. OH indicates the state. The next number, 0010 in the example, is an internal number used in producing the wage determination. 08/29/2014 indicates the survey completion date for the classifications and rates under that identifier.

A UAVG rate will be updated once a year, usually in January of each year, to reflect a weighted average of the current negotiated/CBA rate of the union locals from which the rate is based.

---

## WAGE DETERMINATION APPEALS PROCESS

1.) Has there been an initial decision in the matter? This can be:

- \* an existing published wage determination
- \* a survey underlying a wage determination
- \* a Wage and Hour Division letter setting forth a position on a wage determination matter
- \* a conformance (additional classification and rate) ruling

On survey related matters, initial contact, including requests for summaries of surveys, should be with the Wage and Hour Regional Office for the area in which the survey was conducted because those Regional Offices have responsibility for the Davis-Bacon survey program. If the response from this initial contact is not satisfactory, then the process described in 2.) and 3.) should be followed.

With regard to any other matter not yet ripe for the formal process described here, initial contact should be with the Branch of Construction Wage Determinations. Write to:

Branch of Construction Wage Determinations  
Wage and Hour Division  
U.S. Department of Labor  
200 Constitution Avenue, N.W.  
Washington, DC 20210

2.) If the answer to the question in 1.) is yes, then an interested party (those affected by the action) can request review and reconsideration from the Wage and Hour Administrator (See 29 CFR Part 1.8 and 29 CFR Part 7). Write to:

Wage and Hour Administrator  
U.S. Department of Labor  
200 Constitution Avenue, N.W.  
Washington, DC 20210

The request should be accompanied by a full statement of the interested party's position and by any information (wage payment data, project description, area practice material, etc.) that the requestor considers relevant to the issue.

3.) If the decision of the Administrator is not favorable, an interested party may appeal directly to the Administrative Review Board (formerly the Wage Appeals Board). Write to:

Administrative Review Board  
U.S. Department of Labor  
200 Constitution Avenue, N.W.  
Washington, DC 20210

4.) All decisions by the Administrative Review Board are final.

=====

**END OF GENERAL DECISION"**





2

7



1

4



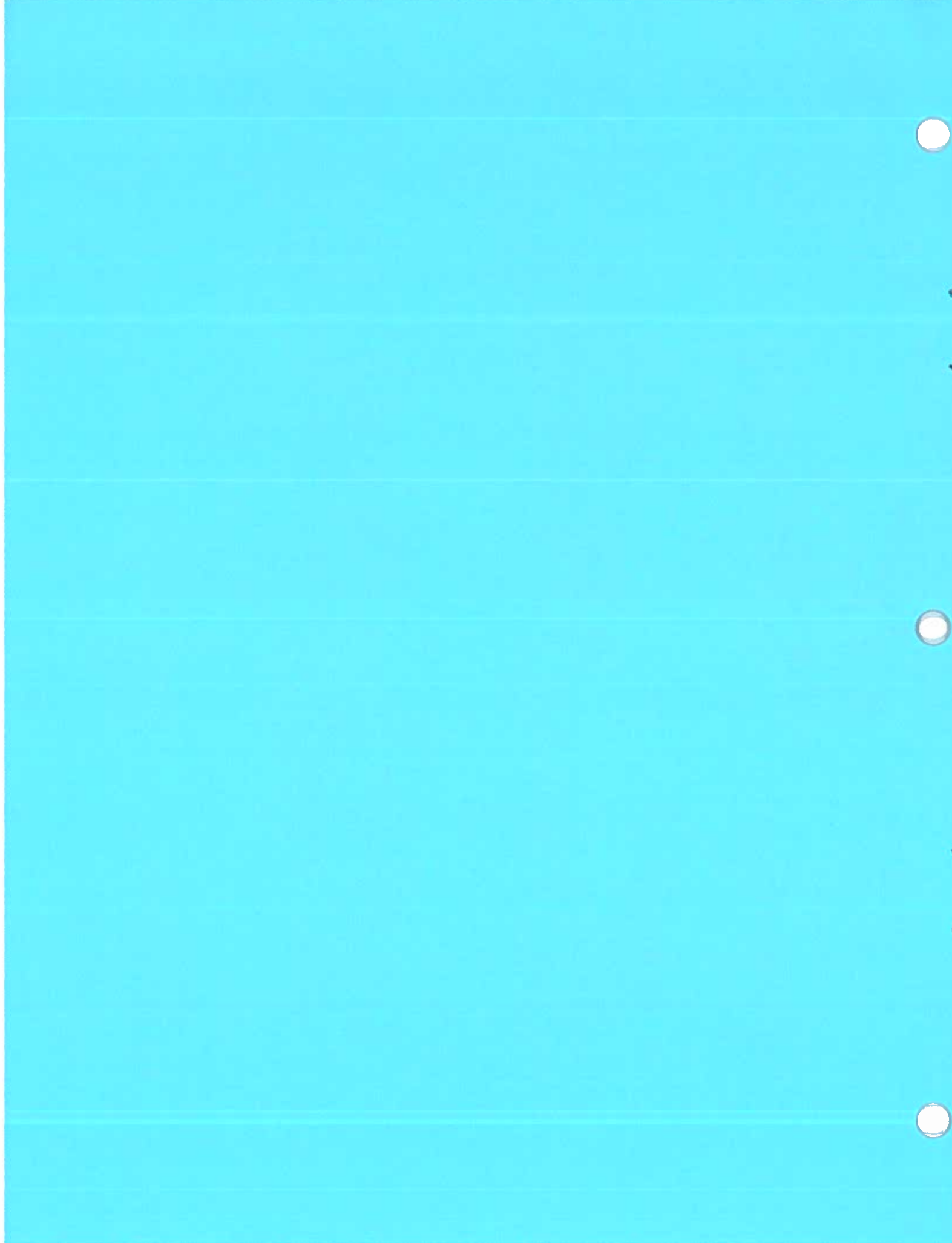





## Federal Letting Requirements-04

This booklet is a compilation of Federal Letting Requirements approved by the Michigan Department of Transportation and the Federal Highway Administration. Any of the Federal Letting Requirements contained herein that are applicable to a specific project shall be referred to in the project proposal and will not be physically attached to that proposal.

## **BIDDER INFORMATION FOR CONSTRUCTION BIDDING**

Electronic Bid – The electronic bid consists of the following tabs: General, Schedule of Items, Designated and Specialty Items, DBE Goal (if applicable), Warranty Obligations, Addenda Acknowledgment and Information.

The Information tab provides an explanation for bidding work items that have a minimum, maximum or specified price and includes the agreement for the bid guaranty sum. The bid guaranty is NOT required at the time of bidding, or with submitting an electronic bid.

*Subject to Subsection 102.17, of the 2012 Standard Specifications for Construction, the bidder agrees to pay to the Michigan Department of Transportation the bid guaranty sum if the bidder fails to provide the required materials and/or execute the contract in accordance with the 2012 Standard Specifications for Construction within twenty-eight (28) days after being sent the necessary award documents.*

All written and electronic addendums issued for project(s) the Bidder elects to bid, must be obtained prior to submitting the electronic bid.

Electronic bids must be submitted by the 10:30 a.m. deadline on the scheduled letting date.

**NOTE:** Any financial or propriety information submitted with the electronic bid will become a public record subject to disclosure under the Freedom of Information Act. THE INFORMATION WILL NOT BE TREATED AS CONFIDENTIAL.

The apparent low Bidder is determined following a review for any discrepancies in the bid and where all requirements of the bid and apparent Bidder are met.

**THE RIGHT IS RESERVED TO REJECT ANY OR ALL BIDS**

*Revised 2/08/2018*

Title 49: Transportation

**PART 26—PARTICIPATION BY DISADVANTAGED BUSINESS ENTERPRISES IN  
DEPARTMENT OF TRANSPORTATION FINANCIAL ASSISTANCE PROGRAMS**

**Subpart A—General**

---

**§26.1 What are the objectives of this part?**

This part seeks to achieve several objectives:

- (a) To ensure nondiscrimination in the award and administration of DOT-assisted contracts in the Department's highway, transit, and airport financial assistance programs;
- (b) To create a level playing field on which DBEs can compete fairly for DOT-assisted contracts;
- (c) To ensure that the Department's DBE program is narrowly tailored in accordance with applicable law;
- (d) To ensure that only firms that fully meet this part's eligibility standards are permitted to participate as DBEs;
- (e) To help remove barriers to the participation of DBEs in DOT-assisted contracts;
- (f) To promote the use of DBEs in all types of federally-assisted contracts and procurement activities conducted by recipients.
- (g) To assist the development of firms that can compete successfully in the marketplace outside the DBE program; and
- (h) To provide appropriate flexibility to recipients of Federal financial assistance in establishing and providing opportunities for DBEs.

**§26.5 What do the terms used in this part mean?**

*Affiliation* has the same meaning the term has in the Small Business Administration (SBA) regulations, 13 CFR part 121.

(1) Except as otherwise provided in 13 CFR part 121, concerns are affiliates of each other when, either directly or indirectly:

- (i) One concern controls or has the power to control the other; or
- (ii) A third party or parties controls or has the power to control both; or
- (iii) An identity of interest between or among parties exists such that affiliation may be found.

(2) In determining whether affiliation exists, it is necessary to consider all appropriate factors, including common ownership, common management, and contractual relationships. Affiliates must be considered together in determining whether a concern meets small business size criteria and the statutory cap on the participation of firms in the DBE program.

*Alaska Native* means a citizen of the United States who is a person of one-fourth degree or more Alaskan Indian (including Tsimshian Indians not enrolled in the Metlaktla Indian Community), Eskimo, or Aleut

blood, or a combination of those bloodlines. The term includes, in the absence of proof of a minimum blood quantum, any citizen whom a Native village or Native group regards as an Alaska Native if their father or mother is regarded as an Alaska Native.

*Alaska Native Corporation (ANC)* means any Regional Corporation, Village Corporation, Urban Corporation, or Group Corporation organized under the laws of the State of Alaska in accordance with the Alaska Native Claims Settlement Act, as amended (43 U.S.C. 1601, *et seq.*).

*Assets* mean all the property of a person available for paying debts or for distribution, including one's respective share of jointly held assets. This includes, but is not limited to, cash on hand and in banks, savings accounts, IRA or other retirement accounts, accounts receivable, life insurance, stocks and bonds, real estate, and personal property.

*Business, business concern or business enterprise* means an entity organized for profit with a place of business located in the United States, and which operates primarily within the United States or which makes a significant contribution to the United States economy through payment of taxes or use of American products, materials, or labor.

*Compliance* means that a recipient has correctly implemented the requirements of this part.

*Contingent Liability* means a liability that depends on the occurrence of a future and uncertain event. This includes, but is not limited to, guaranty for debts owed by the applicant concern, legal claims and judgments, and provisions for federal income tax.

*Contract* means a legally binding relationship obligating a seller to furnish supplies or services (including, but not limited to, construction and professional services) and the buyer to pay for them. For purposes of this part, a lease is considered to be a contract.

*Contractor* means one who participates, through a contract or subcontract (at any tier), in a DOT-assisted highway, transit, or airport program.

*Days* mean calendar days. In computing any period of time described in this part, the day from which the period begins to run is not counted, and when the last day of the period is a Saturday, Sunday, or Federal holiday, the period extends to the next day that is not a Saturday, Sunday, or Federal holiday. Similarly, in circumstances where the recipient's offices are closed for all or part of the last day, the period extends to the next day on which the agency is open.

*Department or DOT* means the U.S. Department of Transportation, including the Office of the Secretary, the Federal Highway Administration (FHWA), the Federal Transit Administration (FTA), and the Federal Aviation Administration (FAA).

*Disadvantaged business enterprise or DBE* means a for-profit small business concern—

(1) That is at least 51 percent owned by one or more individuals who are both socially and economically disadvantaged or, in the case of a corporation, in which 51 percent of the stock is owned by one or more such individuals; and

(2) Whose management and daily business operations are controlled by one or more of the socially and economically disadvantaged individuals who own it.

*DOT-assisted contract* means any contract between a recipient and a contractor (at any tier) funded in whole or in part with DOT financial assistance, including letters of credit or loan guarantees, except a contract solely for the purchase of land.

*Good faith efforts* means efforts to achieve a DBE goal or other requirement of this part which, by their scope, intensity, and appropriateness to the objective, can reasonably be expected to fulfill the program requirement.

*Home state* means the state in which a DBE firm or applicant for DBE certification maintains its principal place of business.

*Immediate family member* means father, mother, husband, wife, son, daughter, brother, sister, grandfather, grandmother, father-in-law, mother-in-law, sister-in-law, brother-in-law, and domestic partner and civil unions recognized under State law.

*Indian tribe* means any Indian tribe, band, nation, or other organized group or community of Indians, including any ANC, which is recognized as eligible for the special programs and services provided by the United States to Indians because of their status as Indians, or is recognized as such by the State in which the tribe, band, nation, group, or community resides. See definition of "tribally-owned concern" in this section.

*Joint venture* means an association of a DBE firm and one or more other firms to carry out a single, for-profit business enterprise, for which the parties combine their property, capital, efforts, skills and knowledge, and in which the DBE is responsible for a distinct, clearly defined portion of the work of the contract and whose share in the capital contribution, control, management, risks, and profits of the joint venture are commensurate with its ownership interest.

*Liabilities* mean financial or pecuniary obligations. This includes, but is not limited to, accounts payable, notes payable to bank or others, installment accounts, mortgages on real estate, and unpaid taxes.

*Native Hawaiian* means any individual whose ancestors were natives, prior to 1778, of the area which now comprises the State of Hawaii.

*Native Hawaiian Organization* means any community service organization serving Native Hawaiians in the State of Hawaii which is a not-for-profit organization chartered by the State of Hawaii, is controlled by Native Hawaiians, and whose business activities will principally benefit such Native Hawaiians.

*Noncompliance* means that a recipient has not correctly implemented the requirements of this part.

*Operating Administration* or *OA* means any of the following parts of DOT: the Federal Aviation Administration (FAA), Federal Highway Administration (FHWA), and Federal Transit Administration (FTA). The "Administrator" of an operating administration includes his or her designees.

*Personal net worth* means the net value of the assets of an individual remaining after total liabilities are deducted. An individual's personal net worth does not include: The individual's ownership interest in an applicant or participating DBE firm; or the individual's equity in his or her primary place of residence. An individual's personal net worth includes only his or her own share of assets held jointly or as community property with the individual's spouse.

*Primary industry classification* means the most current North American Industry Classification System (NAICS) designation which best describes the primary business of a firm. The NAICS is described in the

North American Industry Classification Manual—United States, which is available on the Internet at the U.S. Census Bureau Web site: <http://www.census.gov/eos/www/naics/>.

*Primary recipient* means a recipient which receives DOT financial assistance and passes some or all of it on to another recipient.

*Principal place of business* means the business location where the individuals who manage the firm's day-to-day operations spend most working hours. If the offices from which management is directed and where the business records are kept are in different locations, the recipient will determine the principal place of business.

*Program* means any undertaking on a recipient's part to use DOT financial assistance, authorized by the laws to which this part applies.

*Race-conscious* measure or program is one that is focused specifically on assisting only DBEs, including women-owned DBEs.

*Race-neutral* measure or program is one that is, or can be, used to assist all small businesses. For the purposes of this part, *race-neutral* includes gender-neutrality.

*Recipient* is any entity, public or private, to which DOT financial assistance is extended, whether directly or through another recipient, through the programs of the FAA, FHWA, or FTA, or who has applied for such assistance.

*Secretary* means the Secretary of Transportation or his/her designee.

*Set-aside* means a contracting practice restricting eligibility for the competitive award of a contract solely to DBE firms.

*Small Business Administration* or *SBA* means the United States Small Business Administration.

*SBA certified firm* refers to firms that have a current, valid certification from or recognized by the SBA under the 8(a) BD or SDB programs.

*Small business concern* means, with respect to firms seeking to participate as DBEs in DOT-assisted contracts, a small business concern as defined pursuant to section 3 of the Small Business Act and Small Business Administration regulations implementing it (13 CFR part 121) that also does not exceed the cap on average annual gross receipts specified in §26.65(b).

*Socially and economically disadvantaged individual* means any individual who is a citizen (or lawfully admitted permanent resident) of the United States and who has been subjected to racial or ethnic prejudice or cultural bias within American society because of his or her identity as a members of groups and without regard to his or her individual qualities. The social disadvantage must stem from circumstances beyond the individual's control.

(1) Any individual who a recipient finds to be a socially and economically disadvantaged individual on a case-by-case basis. An individual must demonstrate that he or she has held himself or herself out, as a member of a designated group if you require it.

(2) Any individual in the following groups, members of which are rebuttably presumed to be socially and economically disadvantaged:

(i) "Black Americans," which includes persons having origins in any of the Black racial groups of Africa;

(ii) "Hispanic Americans," which includes persons of Mexican, Puerto Rican, Cuban, Dominican, Central or South American, or other Spanish or Portuguese culture or origin, regardless of race;

(iii) "Native Americans," which includes persons who are enrolled members of a federally or State recognized Indian tribe, Alaska Natives, or Native Hawaiians;

(iv) "Asian-Pacific Americans," which includes persons whose origins are from Japan, China, Taiwan, Korea, Burma (Myanmar), Vietnam, Laos, Cambodia (Kampuchea), Thailand, Malaysia, Indonesia, the Philippines, Brunei, Samoa, Guam, the U.S. Trust Territories of the Pacific Islands (Republic of Palau), Republic of the Northern Marianas Islands, Samoa, Macao, Fiji, Tonga, Kiribati, Tuvalu, Nauru, Federated States of Micronesia, or Hong Kong;

(v) "Subcontinent Asian Americans," which includes persons whose origins are from India, Pakistan, Bangladesh, Bhutan, the Maldives Islands, Nepal or Sri Lanka;

(vi) Women;

(vii) Any additional groups whose members are designated as socially and economically disadvantaged by the SBA, at such time as the SBA designation becomes effective.

(3) Being born in a particular country does not, standing alone, mean that a person is necessarily a member of one of the groups listed in this definition.

*Spouse* means a married person, including a person in a domestic partnership or a civil union recognized under State law.

*Transit vehicle manufacturer* means any manufacturer whose primary business purpose is to manufacture vehicles specifically built for public mass transportation. Such vehicles include, but are not limited to: Buses, rail cars, trolleys, ferries, and vehicles manufactured specifically for paratransit purposes. Producers of vehicles that receive post-production alterations or retrofitting to be used for public transportation purposes (e.g., so-called cutaway vehicles, vans customized for service to people with disabilities) are also considered transit vehicle manufacturers. Businesses that manufacture, mass-produce, or distribute vehicles solely for personal use and for sale "off the lot" are not considered transit vehicle manufacturers.

*Tribally-owned concern* means any concern at least 51 percent owned by an Indian tribe as defined in this section.

*You* refers to a recipient, unless a statement in the text of this part or the context requires otherwise (i.e., 'You must do XYZ' means that recipients must do XYZ).

#### **§26.7 What discriminatory actions are forbidden?**

(a) You must never exclude any person from participation in, deny any person the benefits of, or otherwise discriminate against anyone in connection with the award and performance of any contract covered by this part on the basis of race, color, sex, or national origin.

(b) In administering your DBE program, you must not, directly or through contractual or other arrangements, use criteria or methods of administration that have the effect of defeating or substantially impairing accomplishment of the objectives of the program with respect to individuals of a particular race, color, sex, or national origin.

**§26.13 What assurances must recipients and contractors make?**

(a) Each financial assistance agreement you sign with a DOT operating administration (or a primary recipient) must include the following assurance: The recipient shall not discriminate on the basis of race, color, national origin, or sex in the award and performance of any DOT-assisted contract or in the administration of its DBE program or the requirements 49 CFR part 26. The recipient shall take all necessary and reasonable steps under 49 CFR part 26 to ensure nondiscrimination in the award and administration of DOT-assisted contracts. The recipient's DBE program, as required by 49 CFR part 26 and as approved by DOT, is incorporated by reference in this agreement. Implementation of this program is a legal obligation and failure to carry out its terms shall be treated as a violation of this agreement. Upon notification to the recipient of its failure to carry out its approved program, the Department may impose sanctions as provided for under 49 CFR part 26 and may, in appropriate cases, refer the matter for enforcement under 18 U.S.C. 1001 and/or the Program Fraud Civil Remedies Act of 1986 (31 U.S.C. 3801 et seq.).

(b) Each contract you sign with a contractor (and each subcontract the prime contractor signs with a subcontractor) must include the following assurance: The contractor, sub recipient or subcontractor shall not discriminate on the basis of race, color, national origin, or sex in the performance of this contract. The contractor shall carry out applicable requirements of 49 CFR part 26 in the award and administration of DOT-assisted contracts. Failure by the contractor to carry out these requirements is a material breach of this contract, which may result in the termination of this contract or such other remedy as the recipient deems appropriate, which may include, but is not limited to:

- (1) Withholding monthly progress payments;
- (2) Assessing sanctions;
- (3) Liquidated damages; and/or
- (4) Disqualifying the contractor from future bidding as non-responsible.

**§26.53 What are the good faith efforts procedures recipients follow in situations where there are contract goals?**

(a) When you have established a DBE contract goal, you must award the contract only to a bidder/offeror who makes good faith efforts to meet it. You must determine that a bidder/offeror has made good faith efforts if the bidder/offeror does either of the following things:

- (1) Documents that it has obtained enough DBE participation to meet the goal; or
- (2) Documents that it made adequate good faith efforts to meet the goal, even though it did not succeed in obtaining enough DBE participation to do so. If the bidder/offeror does document adequate good faith efforts, you must not deny award of the contract on the basis that the bidder/offeror failed to meet the goal. See Appendix A of this part for guidance in determining the adequacy of a bidder/offeror's good faith efforts.



(b) In your solicitations for DOT-assisted contracts for which a contract goal has been established, you must require the following:

(1) Award of the contract will be conditioned on meeting the requirements of this section;

(2) All bidders or offerors will be required to submit the following information to the recipient, at the time provided in paragraph (b)(3) of this section:

(i) The names and addresses of DBE firms that will participate in the contract;

(ii) A description of the work that each DBE will perform. To count toward meeting a goal, each DBE firm must be certified in a NAICS code applicable to the kind of work the firm would perform on the contract;

(iii) The dollar amount of the participation of each DBE firm participating;

(iv) Written documentation of the bidder/offeror's commitment to use a DBE subcontractor whose participation it submits to meet a contract goal; and

(v) Written confirmation from each listed DBE firm that it is participating in the contract in the kind and amount of work provided in the prime contractor's commitment.

(vi) If the contract goal is not met, evidence of good faith efforts (see Appendix A of this part). The documentation of good faith efforts must include copies of each DBE and non-DBE subcontractor quote submitted to the bidder when a non-DBE subcontractor was selected over a DBE for work on the contract; and

(3)(i) At your discretion, the bidder/offeror must present the information required by paragraph (b)(2) of this section—

(A) Under sealed bid procedures, as a matter of responsiveness, or with initial proposals, under contract negotiation procedures; or

(B) No later than 7 days after bid opening as a matter of responsibility. The 7 days shall be reduced to 5 days beginning January 1, 2017.

(ii) Provided that, in a negotiated procurement, including a design-build procurement, the bidder/offeror may make a contractually binding commitment to meet the goal at the time of bid submission or the presentation of initial proposals but provide the information required by paragraph (b)(2) of this section before the final selection for the contract is made by the recipient.

(c) You must make sure all information is complete and accurate and adequately documents the bidder/offeror's good faith efforts before committing yourself to the performance of the contract by the bidder/offeror.

(d) If you determine that the apparent successful bidder/offeror has failed to meet the requirements of paragraph (a) of this section, you must, before awarding the contract, provide the bidder/offeror an opportunity for administrative reconsideration.

(1) As part of this reconsideration, the bidder/offeror must have the opportunity to provide written documentation or argument concerning the issue of whether it met the goal or made adequate good faith efforts to do so.

(2) Your decision on reconsideration must be made by an official who did not take part in the original determination that the bidder/offeror failed to meet the goal or make adequate good faith efforts to do so.

(3) The bidder/offeror must have the opportunity to meet in person with your reconsideration official to discuss the issue of whether it met the goal or made adequate good faith efforts to do so.

(4) You must send the bidder/offeror a written decision on reconsideration, explaining the basis for finding that the bidder did or did not meet the goal or make adequate good faith efforts to do so.

(5) The result of the reconsideration process is not administratively appealable to the Department of Transportation.

(e) In a "design-build" or "turnkey" contracting situation, in which the recipient lets a master contract to a contractor, who in turn lets subsequent subcontracts for the work of the project, a recipient may establish a goal for the project. The master contractor then establishes contract goals, as appropriate, for the subcontracts it lets. Recipients must maintain oversight of the master contractor's activities to ensure that they are conducted consistent with the requirements of this part.

(f)(1)(i) You must require that a prime contractor not terminate a DBE subcontractor listed in response to paragraph (b)(2) of this section (or an approved substitute DBE firm) without your prior written consent. This includes, but is not limited to, instances in which a prime contractor seeks to perform work originally designated for a DBE subcontractor with its own forces or those of an affiliate, a non-DBE firm, or with another DBE firm.

(ii) You must include in each prime contract a provision stating:

(A) That the contractor shall utilize the specific DBEs listed to perform the work and supply the materials for which each is listed unless the contractor obtains your written consent as provided in this paragraph (f); and

(B) That, unless your consent is provided under this paragraph (f), the contractor shall not be entitled to any payment for work or material unless it is performed or supplied by the listed DBE.

(2) You may provide such written consent only if you agree, for reasons stated in your concurrence document, that the prime contractor has good cause to terminate the DBE firm.

(3) For purposes of this paragraph, good cause includes the following circumstances:

(i) The listed DBE subcontractor fails or refuses to execute a written contract;

(ii) The listed DBE subcontractor fails or refuses to perform the work of its subcontract in a way consistent with normal industry standards. Provided, however, that good cause does not exist if the failure or refusal of the DBE subcontractor to perform its work on the subcontract results from the bad faith or discriminatory action of the prime contractor;

(iii) The listed DBE subcontractor fails or refuses to meet the prime contractor's reasonable, nondiscriminatory bond requirements.

(iv) The listed DBE subcontractor becomes bankrupt, insolvent, or exhibits credit unworthiness;

(v) The listed DBE subcontractor is ineligible to work on public works projects because of suspension and debarment proceedings pursuant 2 CFR Parts 180, 215 and 1,200 or applicable state law;

(vii) You have determined that the listed DBE subcontractor is not a responsible contractor;

(vi) The listed DBE subcontractor voluntarily withdraws from the project and provides to you written notice of its withdrawal;

(vii) The listed DBE is ineligible to receive DBE credit for the type of work required;

(viii) A DBE owner dies or becomes disabled with the result that the listed DBE contractor is unable to complete its work on the contract;

(ix) Other documented good cause that you determine compels the termination of the DBE subcontractor. Provided, that good cause does not exist if the prime contractor seeks to terminate a DBE it relied upon to obtain the contract so that the prime contractor can self-perform the work for which the DBE contractor was engaged or so that the prime contractor can substitute another DBE or non-DBE contractor after contract award.

(4) Before transmitting to you its request to terminate and/or substitute a DBE subcontractor, the prime contractor must give notice in writing to the DBE subcontractor, with a copy to you, of its intent to request to terminate and/or substitute, and the reason for the request.

(5) The prime contractor must give the DBE five days to respond to the prime contractor's notice and advise you and the contractor of the reasons, if any, why it objects to the proposed termination of its subcontract and why you should not approve the prime contractor's action. If required in a particular case as a matter of public necessity (*e.g.*, safety), you may provide a response period shorter than five days.

(6) In addition to post-award terminations, the provisions of this section apply to pre-award deletions of or substitutions for DBE firms put forward by offerors in negotiated procurements.

(g) When a DBE subcontractor is terminated as provided in paragraph (f) of this section, or fails to complete its work on the contract for any reason, you must require the prime contractor to make good faith efforts to find another DBE subcontractor to substitute for the original DBE. These good faith efforts shall be directed at finding another DBE to perform at least the same amount of work under the contract as the DBE that was terminated, to the extent needed to meet the contract goal you established for the procurement. The good faith efforts shall be documented by the contractor. If the recipient requests documentation under this provision, the contractor shall submit the documentation within 7 days, which may be extended for an additional 7 days if necessary at the request of the contractor, and the recipient shall provide a written determination to the contractor stating whether or not good faith efforts have been demonstrated.

(h) You must include in each prime contract the contract clause required by §26.13(b) stating that failure by the contractor to carry out the requirements of this part is a material breach of the contract and

may result in the termination of the contract or such other remedies set forth in that section you deem appropriate if the prime contractor fails to comply with the requirements of this section.

(i) You must apply the requirements of this section to DBE bidders/offerors for prime contracts. In determining whether a DBE bidder/offeror for a prime contract has met a contract goal, you count the work the DBE has committed to performing with its own forces as well as the work that it has committed to be performed by DBE subcontractors and DBE suppliers.

(j) You must require the contractor awarded the contract to make available upon request a copy of all DBE subcontracts. The subcontractor shall ensure that all subcontracts or an agreement with DBEs to supply labor or materials require that the subcontract and all lower tier subcontractors be performed in accordance with this part's provisions.

#### **§26.55 How is DBE participation counted toward goals?**

(a) When a DBE participates in a contract, you count only the value of the work actually performed by the DBE toward DBE goals.

(1) Count the entire amount of that portion of a construction contract (or other contract not covered by paragraph (a)(2) of this section) that is performed by the DBE's own forces. Include the cost of supplies and materials obtained by the DBE for the work of the contract, including supplies purchased or equipment leased by the DBE (except supplies and equipment the DBE subcontractor purchases or leases from the prime contractor or its affiliate).

(2) Count the entire amount of fees or commissions charged by a DBE firm for providing a bona fide service, such as professional, technical, consultant, or managerial services, or for providing bonds or insurance specifically required for the performance of a DOT-assisted contract, toward DBE goals, provided you determine the fee to be reasonable and not excessive as compared with fees customarily allowed for similar services.

(3) When a DBE subcontracts part of the work of its contract to another firm, the value of the subcontracted work may be counted toward DBE goals only if the DBE's subcontractor is itself a DBE. Work that a DBE subcontracts to a non-DBE firm does not count toward DBE goals.

(b) When a DBE performs as a participant in a joint venture, count a portion of the total dollar value of the contract equal to the distinct, clearly defined portion of the work of the contract that the DBE performs with its own forces toward DBE goals.

(c) Count expenditures to a DBE contractor toward DBE goals only if the DBE is performing a commercially useful function on that contract.

(1) A DBE performs a commercially useful function when it is responsible for execution of the work of the contract and is carrying out its responsibilities by actually performing, managing, and supervising the work involved. To perform a commercially useful function, the DBE must also be responsible, with respect to materials and supplies used on the contract, for negotiating price, determining quality and quantity, ordering the material, and installing (where applicable) and paying for the material itself. To determine whether a DBE is performing a commercially useful function, you must evaluate the amount of work subcontracted, industry practices, whether the amount the firm is to be paid under the contract is

commensurate with the work it is actually performing and the DBE credit claimed for its performance of the work, and other relevant factors.

(2) A DBE does not perform a commercially useful function if its role is limited to that of an extra participant in a transaction, contract, or project through which funds are passed in order to obtain the appearance of DBE participation. In determining whether a DBE is such an extra participant, you must examine similar transactions, particularly those in which DBEs do not participate.

(3) If a DBE does not perform or exercise responsibility for at least 30 percent of the total cost of its contract with its own work force, or the DBE subcontracts a greater portion of the work of a contract than would be expected on the basis of normal industry practice for the type of work involved, you must presume that it is not performing a commercially useful function.

(4) When a DBE is presumed not to be performing a commercially useful function as provided in paragraph (c)(3) of this section, the DBE may present evidence to rebut this presumption. You may determine that the firm is performing a commercially useful function given the type of work involved and normal industry practices.

(5) Your decisions on commercially useful function matters are subject to review by the concerned operating administration, but are not administratively appealable to DOT.

(d) Use the following factors in determining whether a DBE trucking company is performing a commercially useful function:

(1) The DBE must be responsible for the management and supervision of the entire trucking operation for which it is responsible on a particular contract, and there cannot be a contrived arrangement for the purpose of meeting DBE goals.

(2) The DBE must itself own and operate at least one fully licensed, insured, and operational truck used on the contract.

(3) The DBE receives credit for the total value of the transportation services it provides on the contract using trucks it owns, insures, and operates using drivers it employs.

(4) The DBE may lease trucks from another DBE firm, including an owner-operator who is certified as a DBE. The DBE who leases trucks from another DBE receives credit for the total value of the transportation services the lessee DBE provides on the contract.

(5) The DBE may also lease trucks from a non-DBE firm, including from an owner-operator. The DBE that leases trucks equipped with drivers from a non-DBE is entitled to credit for the total value of transportation services provided by non-DBE leased trucks equipped with drivers not to exceed the value of transportation services on the contract provided by DBE-owned trucks or leased trucks with DBE employee drivers. Additional participation by non-DBE owned trucks equipped with drivers receives credit only for the fee or commission it receives as a result of the lease arrangement. If a recipient chooses this approach, it must obtain written consent from the appropriate DOT operating administration.

*Example to paragraph (d)(5):* DBE Firm X uses two of its own trucks on a contract. It leases two trucks from DBE Firm Y and six trucks equipped with drivers from non-DBE Firm Z. DBE credit would be awarded for the total value of transportation services provided by Firm X and Firm Y, and may also be awarded for the total value of transportation services provided by four of the six trucks provided by Firm Z. In all, full credit would be allowed for the participation of eight trucks. DBE credit could be awarded

only for the fees or commissions pertaining to the remaining trucks Firm X receives as a result of the lease with Firm Z.

(6) The DBE may lease trucks without drivers from a non-DBE truck leasing company. If the DBE leases trucks from a non-DBE truck leasing company and uses its own employees as drivers, it is entitled to credit for the total value of these hauling services.

*Example to paragraph (d)(6):* DBE Firm X uses two of its own trucks on a contract. It leases two additional trucks from non-DBE Firm Z. Firm X uses its own employees to drive the trucks leased from Firm Z. DBE credit would be awarded for the total value of the transportation services provided by all four trucks.

(7) For purposes of this paragraph (d), a lease must indicate that the DBE has exclusive use of and control over the truck. This does not preclude the leased truck from working for others during the term of the lease with the consent of the DBE, so long as the lease gives the DBE absolute priority for use of the leased truck. Leased trucks must display the name and identification number of the DBE.

(e) Count expenditures with DBEs for materials or supplies toward DBE goals as provided in the following:

(1)(i) If the materials or supplies are obtained from a DBE manufacturer, count 100 percent of the cost of the materials or supplies toward DBE goals.

(ii) For purposes of this paragraph (e)(1), a manufacturer is a firm that operates or maintains a factory or establishment that produces, on the premises, the materials, supplies, articles, or equipment required under the contract and of the general character described by the specifications.

(2)(i) If the materials or supplies are purchased from a DBE regular dealer, count 60 percent of the cost of the materials or supplies toward DBE goals.

(ii) For purposes of this section, a regular dealer is a firm that owns, operates, or maintains a store, warehouse, or other establishment in which the materials, supplies, articles or equipment of the general character described by the specifications and required under the contract are bought, kept in stock, and regularly sold or leased to the public in the usual course of business.

(A) To be a regular dealer, the firm must be an established, regular business that engages, as its principal business and under its own name, in the purchase and sale or lease of the products in question.

(B) A person may be a regular dealer in such bulk items as petroleum products, steel, cement, gravel, stone, or asphalt without owning, operating, or maintaining a place of business as provided in this paragraph (e)(2)(ii) if the person both owns and operates distribution equipment for the products. Any supplementing of regular dealers' own distribution equipment shall be by a long-term lease agreement and not on an ad hoc or contract-by-contract basis.

(C) Packagers, brokers, manufacturers' representatives, or other persons who arrange or expedite transactions are not regular dealers within the meaning of this paragraph (e)(2).

(3) With respect to materials or supplies purchased from a DBE which is neither a manufacturer nor a regular dealer, count the entire amount of fees or commissions charged for assistance in the procurement of the materials and supplies, or fees or transportation charges for the delivery of materials or supplies required on a job site, toward DBE goals, provided you determine the fees to be reasonable and not

excessive as compared with fees customarily allowed for similar services. Do not count any portion of the cost of the materials and supplies themselves toward DBE goals, however.

(4) You must determine the amount of credit awarded to a firm for the provisions of materials and supplies (e.g., whether a firm is acting as a regular dealer or a transaction expeditor) on a contract-by-contract basis.

(f) If a firm is not currently certified as a DBE in accordance with the standards of subpart D of this part at the time of the execution of the contract, do not count the firm's participation toward any DBE goals, except as provided for in §26.87(i).

(g) Do not count the dollar value of work performed under a contract with a firm after it has ceased to be certified toward your overall goal.

(h) Do not count the participation of a DBE subcontractor toward a contractor's final compliance with its DBE obligations on a contract until the amount being counted has actually been paid to the DBE.

For additional information on DBE contracting requirements, please go to the DBE website at [www.michigan.gov/mdotdbe](http://www.michigan.gov/mdotdbe).

ADD MDOT FORM #2124A WITH INSTRUCTIONS HERE.

ADD MDOT FORM 0196

## DISADVANTAGED BUSINESS ENTERPRISE (DBE) REMOVAL/SUBSTITUTION REQUEST

For projects with Race Conscious DBE Goals, this form MUST be FIRST approved by the Project Engineer then forwarded to MDOT's Office of Business Development for Final Approval. Please fax to (517) 335-0945 or email at [MDOT-DBE@michigan.gov](mailto:MDOT-DBE@michigan.gov).

|                    |                      |
|--------------------|----------------------|
| CONTRACT ID        | PRIME CONTRACTOR     |
| CURRENT DBE GOAL % | PRIME CONTACT PERSON |
| PRIME PHONE        | PRIME EMAIL ADDRESS  |

IF THE DBE BEING REMOVED OR REPLACED IS SUBCONTRACTED WITH A LOWER TIER SUB, NAME THE "PARENT" SUBCONTRACTOR

|                                       |                           |
|---------------------------------------|---------------------------|
| DBE FIRM BEING REMOVED                |                           |
| DOLLAR VALUE COMMITTED TO THIS DBE \$ | WORK PERFORMED TO DATE \$ |
| REASON THIS DBE IS BEING REMOVED      |                           |

WAS THE DBE FIRM GIVEN 5\*\* DAYS WRITTEN NOTICE BEFORE REMOVAL?  YES or  NO If yes, please attach written notice.

WILL THE DBE GOAL FOR THE PROJECT STILL BE MET?  YES or  NO  
If no, has form 0188 been submitted to OBD?  YES or  NO

|   |  |
|---|--|
| SUBSTITUTION SUBCONTRACTOR FIRM NAME (If identified) <input type="checkbox"/> DBE or <input type="checkbox"/> Non-DBE | IF THE SUBSTITUTION FIRM IS A DBE, WAS FORM 0178 SUBMITTED TO CSD?<br><input type="checkbox"/> YES or <input type="checkbox"/> NO If yes, please attach. |
|---|--|

FULLY DESCRIBE THE TYPE OF WORK THE SUBSTITUTE SUBCONTRACTOR WILL PERFORM

DBE credit may be claimed only for types of work in which the DBE firm is both certified and, if required, prequalified. DBE work classification eligibility can be confirmed using the Michigan Unified Certification Program Website at [www.michigan.gov/mucp](http://www.michigan.gov/mucp).

**ACKNOWLEDGED BY**

By signing this replacement form, we certify that the information submitted is accurate and in accordance with the MDOT DBE Program Procedures.

|   |       |      |
|---|-------|------|
| AUTHORIZED SIGNATURE OF REMOVED DBE                 | TITLE | DATE |
| PRIME AUTHORIZED SIGNATURE                          | TITLE | DATE |
| PROJECT ENGINEER AUTHORIZED SIGNATURE               | TITLE | DATE |
| OFFICE OF BUSINESS DEVELOPMENT AUTHORIZED SIGNATURE | TITLE | DATE |

\*\*Per 49 CFR Part 26.53, if required in a particular case as a matter of public necessity (e.g., safety), MDOT may require a response period shorter than five days\*\*

MDOT must be notified immediately of a DBE's inability to perform any or all of its work and the Primes intent to obtain a substitute subcontractor. Primes are required to make a good faith effort to replace a DBE that is unable to perform, with another DBE. If the substitute subcontractor is a DBE, they must be included on the DBE Participation form (MDOT form 0178) and submitted to the Project Engineer and Contract Services Division for approval prior to starting work. Include any trucking or supply forms (4101 & 0193) as necessary.

If the DBE goal will not be met, a Post-Award Good Faith Effort Application (MDOT Form 0188) and all supporting documents must be sent to the Office of Business Development. This post-award application must be submitted within 14 calendar days of the prime vendor being made aware of their inability to meet the DBE participation goal.

Pursuant to 49 CFR Part 26.53 (f), unless consent to replace a DBE is granted by MDOT, the prime contractor shall not be entitled to any payment for work performed or materials supplied.



# PRIME CONTRACTOR BI-WEEKLY STATEMENTS OF SUBCONTRACTOR/SUPPLIER PAYMENTS

Michigan Department  
Of Transportation  
2124A (09/13)

*Portions of the information required in accordance with 49 CFR part 26.37 (as detailed in the prompt payment provisions to monitor the progress of the prime contractor in meeting contractual DBE obligations.)*

**SEE INSTRUCTIONS ON REVERSE**

PRIME CONTRACTOR \_\_\_\_\_ CONTRACT ID \_\_\_\_\_

BI-WEEKLY PERIOD ENDING: \_\_\_\_\_  PROJECT COMPLETION

| SUBCONTRACTOR, DBE TRUCKER, DBE SUPPLIER OR SERVICE PROVIDER | SERVICES/WORK CLASSIFICATION | TOTAL SUB CONTRACT AMOUNT | CUMULATIVE DOLLAR VALUE OF SERVICES COMPLETED | DEDUCTIONS | ACTUAL AMOUNT PAID TO DATE | DBE AUTHORIZED SIGNATURE AT PROJECT COMPLETION ONLY | DATE |
|--|------------------------------|---------------------------|---|------------|----------------------------|---|------|
|  |                              |                           |   |            |                            |   |      |
|  |                              |                           |   |            |                            |   |      |
|  |                              |                           |   |            |                            |   |      |
|  |                              |                           |   |            |                            |   |      |
|  |                              |                           |   |            |                            |   |      |
|  |                              |                           |   |            |                            |   |      |
|  |                              |                           |   |            |                            |   |      |
|  |                              |                           |   |            |                            |   |      |
|  |                              |                           |   |            |                            |   |      |
|  |                              |                           |   |            |                            |   |      |

*As the authorized representative of the above prime contractor, I certify that all payments to non-DBE truckers, and non-DBE suppliers that have performed work or supplied materials to the prime during the reporting period have been made, and I certify that this information is true and accurate.*

CONTRACTORS AUTHORIZED REPRESENTATIVE (Signature) \_\_\_\_\_ TITLE \_\_\_\_\_ DATE \_\_\_\_\_

**FOR THE MICHIGAN DEPARTMENT OF TRANSPORTATION USE ONLY**

COMMENTS \_\_\_\_\_

RESIDENT/PROJECT ENGINEER (Signature) \_\_\_\_\_ DATE \_\_\_\_\_

# INSTRUCTIONS

## PRIME CONTRACTOR or AUTHORIZED REPRESENTATIVE

This statement reports the actual dollar amounts of the project cost earned by and paid to all subcontractors, DBE subcontractors, DBE suppliers, and DBE truckers. Complete and submit to the Resident/Project Engineer on a bi-weekly basis during the course of the project using the MERS database. This submittal is required prior to release of the second and subsequent estimates per FUSP 109(A). A hard copy of this form must also be submitted 30 days after project completion with actual DBE signatures (not using MERS).

For "Control Section" and "Job No." Use the numbers assigned by MDOT.

For *Services/Work Classification*, report services/work performed by DBE subcontractors, DBE suppliers, DBE truckers, and DBE consultants listed by work classification code. If they are performing work in more than one classification, report the code with the largest dollar value. A list of work classification codes is available at [www.michigan.gov/mucp](http://www.michigan.gov/mucp).

For "*Total Subcontract Amount*", report total amount of the contract between the prime contractor and the subcontractor.

For "*Deductions*", report deductions made by the prime contractor to the subcontractor's "*Cumulative Dollar Value of Services Completed*" for bond or other fees, materials, services or equipment provided to the subcontractor according to mutual, prior agreement (documentation of such agreement may be required by MDOT).

For "*Actual Amount Paid to Date*", report cumulative actual payments made to the subcontractor for services completed.

Provide "*DBE Authorized Signature*" on the project completion report.

Be sure to sign, title and date the project completion report.

## MDOT RESIDENT/PROJECT ENGINEER:

Please complete the "Comments" area, date and submit within the MERS database within 7 days of receipt from prime. Please complete the "Comments" area, sign, date, and fax the **project completion report** only to 517-335-0945 or email to [paymentstatements@michigan.gov](mailto:paymentstatements@michigan.gov) within 7 days of receipt from prime.

MDOT Office of Business Development  
P.O. Box 30050

Lansing, Michigan 48909

Questions about this form? Call Toll-free, 1866-DBE-1264

**STATE ADMINISTRATIVE BOARD**  
**RESOLUTION 2017-2**  
**PROCEDURES APPLICABLE TO MDOT CONTRACTS AND GRANTS**  
**AND**  
**RECISSION OF RESOLUTION 2011-2**

WHEREAS, the State Administrative Board ("Board") exercises general supervisory control over the functions and activities of all administrative departments, boards, commissioners, and officers of this State, and of all State institutions pursuant to Section 3 of 1921 PA 2, MCL 17.3;

WHEREAS, the Board may adopt rules governing its procedures and providing for the general conduct of its business and affairs pursuant to Section 2, of 1921 PA 2, MCL 17.2;

WHEREAS, exercising its power to adopt rules, the Board adopted Resolution 2011-2 on August 30, 2011, establishing a \$500,000 or more threshold for Board approval of the Michigan Department of Transportation ("MDOT") Professional Engineering Consultant Contracts and Construction Contracts and increasing the threshold for Board approval for Service Contracts to \$250,000 or more for initial contracts and \$125,000 or more for an amendment to a Service Contract;

WHEREAS, the Board has adopted Resolution 2017-1, raising the threshold for Board approval of contracts for materials and services to \$500,000 or more for the initial contract and \$500,000 or more for contract amendments, and rescinding Resolution 2011-1;

WHEREAS, MDOT is a party to a considerable number of contracts, the majority of which are funded via grants administered by federal agencies including the U.S. Department of Transportation's Federal Highway Administration, Federal Transit Administration, Federal Railroad Administration, and Federal Aviation Administration, which oversee MDOT's administration of such contracts and amendments thereto;

WHEREAS, MDOT has implemented internal procedures to assure the proper expenditure of state and federal funds and is subject to financial and performance audits by the Office of Commission Audits pursuant to 1982 PA 438, MCL 247.667a;

WHEREAS, MDOT is a party to a significant number of contracts which by their nature involve substantial consideration and often require amendments

arising out of changes in scope, differing field conditions and design errors and omissions;

WHEREAS, delays in the approval of amendments to contracts can result in: postponement of payments to subcontractors and suppliers; work slowdowns and stoppages; delays in the completion of projects; exposure to additional costs; and exposure to litigation arising out of contractor claims; and

WHEREAS, recognizing the Board's duty to promote the efficiency of State Government, the Board resolves as follows:

1. Resolution 2011-2 is rescinded.
2. A contract for professional design, engineering or consulting services requiring MDOT prequalification in connection with the construction or physical improvement of a street, road, highway, bridge, transit or rail system, airport or other structure congruous with transportation ("Professional Engineering Consultant Contract") or a contract for the construction or physical improvement of a street, road, highway, bridge, transit or rail system, airport or other structure congruous with transportation ("Construction Contract") must be approved by the Board prior to execution by MDOT if the amount of the contract is \$500,000 or more. MDOT may obtain approval of the solicitation of a Professional Engineering Consultant Contract or a Construction Contract which, based on the estimate prepared by an engineer employed by the State of Michigan, is estimated to be \$500,000 or more. A contract arising out of such solicitation must be approved by the Board prior to execution by MDOT if the amount of the contract exceeds 110% of the State engineer's estimate.
3. An amendment to a Professional Engineering Consultant Contract or a Construction Contract must be approved by the Board prior to execution by MDOT if the amount of the amendment and the sum of all previous amendments exceed 10% of the original contract, except that an amendment to a Professional Engineering Consultant Contract or a Construction Contract need not be approved by the Board if: a) approved in accordance with applicable federal law or procedure by a representative of a federal agency contributing funds to the project that is the subject of the contract; or b) approved in accordance with MDOT's internal procedures provided the procedures include approval by at least one MDOT employee who has managerial responsibility and is neither the project manager nor directly involved in the administration of the project.
4. A contract for services not requiring MDOT prequalification ("Service Contract") in the amount of \$500,000 or more must be approved by the Board prior to execution by MDOT. A Service Contract does not include a Professional Engineering Consultant Contract or a Construction Contract.

5. An amendment to a Service Contract must be approved by the Board prior to execution by MDOT if the amount of the amendment and the sum of all previous amendments total \$500,000 or more. Thereafter, an amendment to a Service Contract must be approved by the Board if the amount of the amendment and the sum of all amendments executed after the most recent Board approval total \$500,000 or more.

6. A contract involving the conveyance of any real property interest under the jurisdiction of MDOT must be approved by the Board prior to execution by MDOT if the fair market value of the interest is \$500,000 or more. Fair market value must be determined in accordance with procedures approved by the State Transportation Commission.

7. MDOT may enter in to a contract with a sub-recipient without approval of the Board if: a) the purpose of the contract is to provide federal or state matching funds for a project; b) MDOT has been authorized by an agency administering any federal funds to award them to the sub-recipient; and c) the sub-recipient has agreed to fully reimburse the State in the event the sub-recipient does not use the funds in accordance with the purpose of the funding. A sub-recipient includes, but is not limited to, a local unit of government, a governmental authority, a private non-profit entity, a railroad or rail service provider.

8. MDOT may enter in to a cost participation contract with a local unit of government without approval of the Board if: a) the contract involves the construction or physical improvement of a street, road, highway, bridge or other structure congruous with transportation; b) the construction or improvement is funded by federal, state or local funds; and c) the contract is approved by each entity providing funds or in accordance with applicable law.

9. MDOT may enter in to a contract in connection with the award of a grant including state matching funds, to a local unit of government, a governmental authority, a private non-profit entity, a railroad or a rail service provider, without approval of the Board if the contract provides that the recipient will fully reimburse the State in the event grant funds are not used in accordance with the terms of the grant.

10. MDOT may enter in to a contract with an airport sponsor without approval of the Board if the contract has been approved by the Michigan Aeronautics Commission.

11. MDOT may enter in to a contract or award a grant without approval of the Board in situations where emergency action is required. For all emergency contracts or grants of \$250,000 or more, MDOT must transmit to the Board a

written report setting forth the nature of the emergency and the key terms of the contract or grant within 30 days of executing the contract or awarding the grant.

12. Notwithstanding any provisions of this resolution, the Board may require MDOT to report the status of any project and may require MDOT to obtain Board approval of any contract, grant or any amendment to a contract.

This Resolution is effective April 25, 2017.



## PROOF OF INSURANCE FOR CONSTRUCTION AND RECONSTRUCTION OF MICHIGAN DEPARTMENT OF TRANSPORTATION HIGHWAY/AERONAUTICS PROJECTS

*Information required by the Federal specifications for Highway construction and/or Act 327, P.A. of 1945 to verify insurance.*

**INSTRUCTIONS:** Complete and return to MDOT-Awards@michigan.gov.

The subscribing insurance company certifies that insurance of the types and for limits of liability covering the work under contract with MDOT or airport owner has been obtained by the contractor named below.

Such insurance, here certified, is written in accordance with the company's regular policies and endorsements subject to the company's applicable manuals of rules and rates, except (1) the insurance shall not be subject to the usual "x" - explosion, "c" - collapse or "u" - underground property damage exclusions.

|                 |         |       |          |
|-----------------|---------|-------|----------|
| NAME OF INSURED |         |       |          |
| ADDRESS         | CITY    | STATE | ZIP CODE |
| TELEPHONE NO.   | FAX NO. |       |          |

| TYPE OF INSURANCE  | POLICY NUMBER & NAME OF INSURANCE COMPANY<br>(If more than one) | POLICY DATES<br>(MM/DD/YY) |            | LIMITS: Each Occurrence: \$1,000,000<br>Aggregate: \$2,000,000<br>BODILY INJURY AND PROPERTY DAMAGE LIABILITY |                          |
|--|---|----------------------------|------------|---|--------------------------|
|  |   | EFFECTIVE                  | EXPIRATION |   |                          |
| <input type="checkbox"/> General Liability                               |   |                            |            | General Aggregate   | \$                       |
| <input type="checkbox"/> Commercial General Liability                    |   |                            |            | Prods. comp/ops Aggregate   | \$                       |
| <input type="checkbox"/> Claims Made <input type="checkbox"/> Occurrence |   |                            |            | Personal & Advertising Inj.   | \$                       |
| <input type="checkbox"/> \$_____ P.D. Deductible                         |   |                            |            | Each Occurrence   | \$                       |
| <input type="checkbox"/> XCU Exclusion                                   |   |                            |            | Fire Damage (any one fire)  | \$                       |
| <input type="checkbox"/> Contractual Exclusion                           |   |                            |            | Medical Exp. (any one person)   | \$                       |
| <b>AUTOMOTIVE LIABILITY</b>  |   |                            |            |   |                          |
| <input type="checkbox"/> Any Auto  |   |                            |            | Combined Single Limit<br>(Minimum \$2,000,000.00)   | \$                       |
| <input type="checkbox"/> All Owned Autos                                 |   |                            |            | Bodily Injury (per person)<br>(Minimum \$500,000.00)  | \$                       |
| <input type="checkbox"/> Scheduled Autos                                 |   |                            |            | Bodily Injury (per accident)<br>(Minimum \$1,000,000.00)  | \$                       |
| <input type="checkbox"/> Hired Autos                                     |   |                            |            | Property Damage<br>(Minimum \$1,000,000.00)   | \$                       |
| <input type="checkbox"/> Non-Owned Autos                                 |   |                            |            |   |                          |
| <input type="checkbox"/> Garage Liability                                |   |                            |            |   |                          |
| <input type="checkbox"/> Umbrella  |   |                            |            | Each Occurrence   | \$                       |
|  |   |                            |            | Aggregate   | \$                       |
| <input type="checkbox"/> Excess Liability Other Than Umbrella            |   |                            |            | Each Occurrence   | \$                       |
|  |   |                            |            | Aggregate   | \$                       |
| <b>WORKERS COMPENSATION AND EMPLOYERS LIABILITY</b>                      |   |                            |            | <b>STATUTORY</b>  |                          |
|  |   |                            |            | \$  | (Each Accident)          |
|  |   |                            |            | \$  | (Disease - Policy Limit) |
|  |   |                            |            | \$  | (Disease - Each Empl.)   |
| <input type="checkbox"/> Other   |   |                            |            |   |                          |

|  |         |  |          |  |      |
|--|---------|--|----------|--|------|
| NAME OF AGENCY                                 |         | NAME OF INSURANCE COMPANY (if only one for all policies) |          |  |      |
| ADDRESS  | CITY    | STATE  | ZIP CODE |  |      |
| TELEPHONE NO.                                  | FAX NO. |  |          |  |      |
| AUTHORIZED REPRESENTATIVE SIGNATURE (Required) |         |  |          |  | DATE |

**APPENDIX A**  
**PROHIBITION OF DISCRIMINATION IN STATE CONTRACTS**

In connection with the performance of work under this contract; the contractor agrees as follows:

1. In accordance with Act. No. 453, Public Acts of 1976, the contractor hereby agrees not to discriminate against an employee or applicant for employment with respect to hire, tenure, terms, conditions, or privileges of employment, or a matter directly or indirectly related to employment, because of race, color, religion, national origin, age, sex, height, weight, or marital status. Further, in accordance with Act No. 220, Public Acts of 1976 as amended by Act No. 478, Public Acts of 1980, the contractor hereby agrees not to discriminate against an employee or applicant for employment tenure, terms, conditions, or privileges of employment, or a matter directly or indirectly related to employment, because of a disability that is unrelated to the individual's ability to perform the duties of a particular job or position. A breach of the above covenants shall be regarded as a material breach of this contract.
2. The contractor hereby agrees that any and all subcontractors to this contract, whereby a portion of the work set forth in this contract is to be performed, shall contain a covenant the same as in herein before set forth in section 1 of this Appendix.
3. The contractor will take affirmative action to insure that applicants for employment and employees are treated without regard to their race, color, religion, national origin, sex, height, weight, marital status or disability that is unrelated to the individual's ability to perform the duties of a particular job or position. Such action shall include, but not be limited to the following; employment, upgrading, demotion or transfer, recruitment advertising; layoff or termination; rates of pay or other forms of compensation; and selection for training, including apprenticeship.
4. The contractor will, in all solicitations or advertisements for employees placed by or on behalf of the contractor, state that all qualified applicants will receive consideration for employment without regard to race, color, religion, national origin, age, sex, height, marital status or disability that is unrelated to the individuals ability to perform the duties of a particular job or position.
5. The contractor or his collective bargaining representative will send to each labor union or representative of workers with which he has a collective bargaining agreement or other contract or understanding, a notice advising the said labor union or workers' representative of the contractor's commitments under this appendix.
6. The contractor will comply with relevant published rules, regulations, directives, and orders of the Michigan Civil Rights Commission which may be in effect prior to the taking of bids for any individual state project.
7. The contractor will furnish and file compliance reports within such time and upon such forms as provided by the Michigan Civil Rights Commission, said forms may also elicit information as to the practices, policies, program and employment statistics of each subcontractor as well as the contractor himself, and said contractor will permit access to his books, records, and accounts by the Michigan Civil Rights Commission, and/or its agent, for purposes of investigation to ascertain compliance with this contract and relevant with rules, regulations, and orders of the Michigan Civil Rights Commission.
8. In the event that the Civil Rights Commission finds, after a hearing held pursuant to its rules, that a contractor has not complied with the contractual obligations under this agreement, the Civil Rights Commission may, as a part of its order based upon such findings, certify said findings to the Administrative Board of the State of Michigan, which Administrative Board may order the cancellation of the contract found to have been violated, and/or declare the contractor ineligible for future contracts with the state and its political and civil subdivisions, departments, and officers, and including the governing boards of institutions of higher education, until the contractor complies with all of the persons with whom the contractor is declared ineligible to contract as a contracting party in future contracts. In any case before the Civil Rights Commission in which cancellation of an exiting contract is a possibility, the contracting agency shall be notified of such possible remedy and shall be given the option by the Civil Rights Commission to participate in such proceedings.
9. The contractor will include, or incorporate by reference, the provisions of the forgoing paragraphs (1) through (8) in every subcontract or purchase order unless exempted by rules, regulations or orders of the Michigan Civil Rights Commission, and will provide in every subcontract or purchase order that said provisions will be binding upon each subcontractor or seller.

*\*The Civil Rights Commission referred to as the Michigan Civil Rights Commission*



## TITLE VI ASSURANCE

### APPENDIX C

During the performance of this contract, the contractor, for itself, its assignees and successors in interest (hereinafter referred to as the "contractor") agrees as follows:

1. **Compliance with Regulations:** The contractor shall comply with the Regulations relative to nondiscrimination in Federally-assisted programs of the Department of Transportation, Title 49, code of Federal Regulations, Part 21, as they may be amended from time to time, (hereinafter referred to as the Regulations), which are herein incorporated by reference and made a part of this contract.
2. **Nondiscrimination:** The contractor, with regard to the work performed by it during the contract, shall not discriminate on the grounds of race, color, national origin, sex, age, or disability in the selection and retention of subcontractors, including procurements of materials and leases of equipment. The contractor shall not participate either directly or indirectly in the discrimination prohibited by section 21.5 of the Regulation, including employment practices when the contractor covers a program set forth in Appendix B of the Regulations.
3. **Solicitations for Subcontracts, Including Procurements of Materials and Equipment:** In all solicitations either by competitive bidding or negotiation made by the contractor for work to be performed under a subcontract, including procurements of materials or leases of equipment, each potential subcontractor or supplier shall be notified by the contractor of the contractor's obligations under the contract and the Regulations relative to nondiscrimination on the grounds of race, color, national origin, sex, age, or disability.
4. **Information and Reports:** The contractor shall provide all information and reports required by the Regulations, or directives issued pursuant thereto, and shall permit access to its books, records, accounts, other sources of information, and its facilities as may be determined by the State Highway department of the Federal Highway Administration to be pertinent to ascertain compliance with such Regulations or directives. Where any information required of a contractor is in the exclusive possession of another who fails or refuses to furnish this information, the contractor shall so certify to the State highway department, or the Federal Highway Administration as appropriate, and shall set forth what efforts it has made to obtain the information.
5. **Sanctions for Noncompliance:** In the event of the contractor's noncompliance with the nondiscrimination provisions of this contract, the State highway department shall impose such contract sanctions as it or the Federal Highway Administration may determine to be appropriate, including, but not limited to:
  - (a) withholding of payments to the contractor under the contract until the contractor complies, and/or
  - (b) cancellation, termination or suspension of the contract, in whole or in part.
6. **Incorporation of Provisions:** The contractor shall include the provisions of paragraphs (1) through (6) in every subcontract, including procurement of materials and leases of equipment, unless exempt by the Regulations, or directives issued pursuant thereto. The contractor shall take such action with respect to any subcontract or procurement as the State highway department or the Federal Highway Administration may direct as a means of enforcing such provisions including sanctions for non-compliance: Provided, however, that, in the event a contractor becomes involved in, or is threatened with, litigation with a subcontractor or supplier as a result of such direction, the contractor may request the State highway department to enter into such litigation to protect the interests of the State, and, in addition, the contractor may request the United States to enter into such litigation to protect the interests of the United States

## COUNTY MINORITY & FEMALE\* PERCENTAGES

|                        |                        |                         |
|------------------------|------------------------|-------------------------|
| 1. Alcona_____5.2%     | 29. Gratiot_____5.2%   | 57. Missaukee____4.9%   |
| 2. Alger_____1.0%      | 30. Hillsdale____5.5%  | 58. Monroe_____8.8%     |
| 3. Allegan_____4.9%    | 31. Houghton____1.0%   | 59. Montcalm____4.9%    |
| 4. Alpena_____5.2%     | 32. Huron _____5.2%    | 60. Montmorency_5.2%    |
| 5. Antrim_____4.9%     | 33. Ingham_____5.5%    | 61. Muskegon____9.7%    |
| 6. Arenac_____5.2%     | 34. Ionia_____5.5%     | 62. Newaygo_____4.9%    |
| 7. Baraga_____1.0%     | 35. Iosco_____5.2%     | 63. Oakland_____17.7%   |
| 8. Barry_____7.2%      | 36. Iron_____1.0%      | 64. Oceana_____9.7%     |
| 9. Bay_____2.2%        | 37. Isabella_____5.2%  | 65. Ogemaw_____5.2%     |
| 10. Benzie_____4.9%    | 38. Jackson_____5.1%   | 66. Ontonagon___1.2%    |
| 11. Berrien_____6.2%   | 39. Kalamazoo___5.9%   | 67. Osceola_____4.9%    |
| 12. Branch_____5.5%    | 40. Kalkaska____4.9%   | 68. Oscoda_____5.2%     |
| 13. Calhoun_____7.2%   | 41. Kent_____5.2%      | 69. Otsego_____5.2%     |
| 14. Cass_____6.2%      | 42. Keweenaw___1.0%    | 70. Ottawa_____5.2%     |
| 15. Charlevoix___4.9%  | 43. Lake_____4.9%      | 71. Presque Isle__5.2%  |
| 16. Cheboygan___5.2%   | 44. Lapeer_____17.7%   | 72. Roscommon___5.2%    |
| 17. Chippewa___5.2%    | 45. Leelanau____4.9%   | 73. Saginaw_____14.3%   |
| 18. Clare_____5.2%     | 46. Lenawee_____7.3%   | 74. Sanilac_____16.7%   |
| 19. Clinton_____5.5%   | 47. Livingston___17.5% | 75. Schoolcraft___1.0%  |
| 20. Crawford_____5.2%  | 48. Luce_____5.2%      | 76. Shiawassee__12.6%   |
| 21. Delta_____1.0%     | 49. Mackinac____5.2%   | 77. St. Clair_____17.7% |
| 22. Dickinson___1.0%   | 50. Macomb_____17.7%   | 78. St. Joseph____5.2%  |
| 23. Eaton_____5.5%     | 51. Manistee____4.9%   | 79. Tuscola_____5.2%    |
| 24. Emmet_____4.9%     | 52. Marquette___1.0%   | 80. VanBuren_____5.9%   |
| 25. Genesee___12.6%    | 53. Mason_____4.9%     | 81. Washtenaw___8.5%    |
| 26. Gladwin_____5.2%   | 54. Mecosta_____4.9%   | 82. Wayne_____17.7%     |
| 27. Gogebic_____1.2%   | 55. Menominee___1.0%   | 83. Wexford_____4.9%    |
| 28. Gr. Traverse__4.9% | 56. Midland_____5.2%   |                         |

\*The construction goal for women in any Michigan county is 6.9%

Minority and female percentages are taken from the Office of Federal Contract Compliance Program Statistics.

**Notice of Requirement for Affirmative Action  
To Ensure Equal Employment Opportunity for Construction  
(EXECUTIVE ORDER 11246)**

1. The offeror's or bidder's attention is called to the Equal Opportunity clause and the Affirmative Action Compliance Requirements for Construction clause of this solicitation.
2. The goals for minority and female participation, expressed in percentage terms for the Contractor's aggregate workforce in each trade on all construction work in the covered area, are as follows:

| Goals for Minority participation for each trade  | Goals for Female participation for each trade |
|--|---|
| See County Minority and Female Percentages chart | 6.9%  |

These goals are applicable to all Contractor's construction work performed in the covered area. If the Contractor performs construction work in a geographical area located outside of the covered area, the Contractor shall apply the goals established for the geographical area where the work is actually performed. With regard to this second area, the contractor also is subject to the goals for both its federally involved and non-federally involved construction.

The Contractor's compliance with Executive Order 11246, as amended, and the regulations in 41 CFR 60-4 shall be based on (1) its implementation of the Equal Opportunity clause, (2) specific affirmative action obligations required by the clause entitled *Affirmative Action Compliance Requirements for Construction*, and (3) its efforts to meet the goals. The hours of minority and female employment and training must be substantially uniform throughout the length of the contract, and in each trade. The Contractor shall make a good faith effort to employ minorities and women evenly on each of its projects. The transfer of minority or female employees or trainees from Contractor to Contractor or from project to project, for the sole purpose of meeting the Contractor's goals shall be a violation of the contract, Executive Order 11246, as amended, and the regulations in 41 CFR 60-4. Compliance with the goals will be measured against the total work hours performed.

3. The Contractor shall provide written notification to the Deputy Assistant Secretary for Federal Contract Compliance, U.S. Department of Labor, within 10 working days following award of any construction subcontract in excess of \$10,000 at any tier for construction work under the contract resulting from this solicitation. The notification shall list the—
  - Name, address, and telephone number of the subcontractor;
  - Employer's identification number of the subcontractor;
  - Estimated dollar amount of the subcontract;
  - Estimated starting and completion dates of the subcontract; and
  - Geographical area in which the subcontract is to be performed.
4. For this Notice, and in any contract resulting from this solicitation, the covered area is the county or counties listed in the Notice of Advertisement. When multiple counties are listed, the minority participation percentage is determined by the covered area county with the greater percentage.

[48 FR 42478, Sept. 19, 1983, as amended at 55 FR 38518, Sept. 18, 1990; 63 FR 70286, Dec. 18, 1998]

**STANDARD FEDERAL EQUAL EMPLOYMENT OPPORTUNITY  
CONSTRUCTION CONTRACT SPECIFICATIONS  
(EXECUTIVE ORDER 11246)**

1. **As used in these specifications:**
  - a. **"Covered area" means the geographical area described in the solicitation from which this contract resulted;**
  - b. **"Director" means Director, Office of Federal Contract Compliance Programs, United States Department of Labor, or any person to whom the Director delegates authority;**
  - c. **"Employer identification number" means the Federal Social Security number used on the Employer's Quarterly Federal Tax Return, U.S. Treasury Department Form 941.**
  - d. **"Minority" includes:**
    - (i) **Black (all person having origins in any of the Black African racial groups not of Hispanic origin); and**
    - (ii) **Hispanic (all persons of Mexican, Puerto Rican, Cuban, Central or South American or other Spanish Culture of origin, regardless of race); and**
    - (iii) **Asian and Pacific Islander (all persons having origins in any of the original peoples of the Far East, South East Asia, the Indian Subcontinent, or the Pacific Islands); and**
    - (iv) **American Indian or Alaskan Native (all persons having origins in any of the original peoples of North America and maintaining identifiable tribal affiliations through membership and participation and participation or community identification).**
2. **Whenever the Contractor, or any Subcontractor at any tier, subcontracts a portion of the work involving any construction trade, it shall physically include in each subcontract in excess of \$10,000 the provisions of these specifications and the Notice which contains the applicable goals for minority and female participation and which is set forth in the solicitation from which this contract resulted.**
3. **If the Contractor is participating (pursuant to 41 CFR 60.4.5) in a Hometown Plan approved by the U.S. Department of Labor in the covered area either individually or through an association, its affirmative action obligations on all work in the Plan area (including goals and timetables) shall be in accordance with that Plan for those trades which have unions participating in the Plan. Contractors must be able to demonstrate their participation in and compliance with the provisions of any such**

**Hometown Plan. Each Contractor or Subcontractor participating in an approved Plan is individually required to comply with its obligations under the EEO clause, and to make good faith effort to achieve each goal under the Plan in each trade in which it has employees. The overall good faith performance by other Contractors or Subcontractors toward a goal in an approved Plan does not excuse any covered Contractor's or Subcontractor's failure to take good faith efforts to achieve the Plan goals and timetables.**

- 4. The Contractor shall implement the specific affirmative action standards provided in paragraph 7a through p of these specifications. The goals set forth in the solicitation from which this contract resulted are expressed as percentages of the total hours of employment and training of minority and female utilization the Contractor should reasonably be able to achieve in each construction trade in which it has employees in the covered area. Covered construction contractors performing construction work in geographical areas where they do not have a Federal or federally assisted construction contract shall apply the minority and female goals established for the geographical area where the work is being performed. Goals are published periodically in the Federal Register in notice form, and such notices may be obtained from any Office of Federal Contract Compliance Programs office or from Federal procurement contracting officers. The Contractor is expected to make substantially uniform progress in meeting its goals in each craft during the period specified.**
- 5. Neither the provisions of any collective bargaining agreement, nor the failure by a union with whom the Contractor has collective bargaining agreement, to refer either minorities or women shall excuse the Contractor's obligations under these specifications, Executive Order 11246, or the regulations promulgated pursuant thereto.**
- 6. In order for the nonworking training hours of apprentices and trainees to be counted in meeting the goals, such apprentices and trainees must be employed by the Contractor during the training period, and the Contractor must have made a commitment to employ the apprentices and trainees at the completion of their training, subject to the availability of employment opportunities. Trainees must be trained pursuant to training programs approved by the U.S. Department of Labor.**
- 7. The Contractor shall take specific affirmative actions to ensure equal employment opportunity. The evaluation of the Contractor's compliance with these specifications shall be based upon its effort to achieve maximum results from its actions. The Contractor shall document these efforts fully, and shall implement affirmative action steps at least as extensive as the following:**
  - a. Ensure and maintain a working environment free of harassment, intimidation, and coercion at all sites, and in all facilities at which the Contractor's employees are assigned to work. The Contractor, where possible, will assign two or more women to each construction project. The Contractor shall specifically ensure that all foremen, superintendents, and other on-site supervisory personnel are aware of and carry out the Contractor's obligation to maintain such a working environment, with specific attention to minority or female individuals working at such sites or in such facilities.**
  - b. Establish and maintain a current list of minority and female recruitment sources, provide written notification to minority and female recruitment sources and to community organizations when the Contractor or its unions have employment opportunities available, and maintain a record of the organizations' responses.**
  - c. Maintain a current file of the names, addresses and telephone numbers of each minority and female off-the-street applicant and minority or female referral from a**

union, a recruitment source or community organization and of what action was taken with respect to each such individual. If such individual was sent to the union hiring hall for referral and was not referred back to the Contractor by the union or, if referred, not employed by the Contractor, this shall be documented in the file with the reason therefor, along with whatever additional actions the Contractor may have taken.

- d. **Provide immediate written notification to the Director when the union or unions with which the Contractor has a collective bargaining agreement has not referred to the Contractor a minority person or woman sent by the Contractor, or when the Contractor has other information that the union referral process has impeded the contractor's efforts to meet its obligations.**
- e. **Develop on-the-job training opportunities and/or participate in training programs for the area which expressly include upgrading programs and apprenticeship and trainee programs relevant to the contractor's employment needs, especially those programs funded or approved by the Department of Labor. The Contractor shall provide notice of these programs to the sources complied under 7b above.**
- f. **Disseminate the Contractor's EEO policy by providing notice of the policy to unions and training programs and requesting their cooperation in assisting the Contractor in meeting its EEO obligations; by including it in any policy review of the policy with all management personnel and with all minority and female employees at least once a year; and by posting the company EEO policy on bulletin boards accessible to all employees at each location where construction is performed.**
- g. **Review, at least annually, the company's EEO policy and affirmative action obligations under these specifications with all employees having any responsibility for hiring, assignment, layoff, termination or other employment decisions including specific review of these items with onsite supervisory personnel such as Superintendents, General Foremen, etc., prior to the initiation of construction work at any job site. A written record shall be made and maintained identifying the time and place of these meetings, persons attending, subject matter discussed, and disposition of the subject matter.**
- h. **Disseminate the Contractor's EEO policy externally by including it in any advertising in the news media, specifically including minority and female news media, and providing written notification to and discussing the Contractor's EEO policy with other Contractors and Subcontractors with whom the Contractor does or anticipates doing business.**
- i. **Direct its recruitment efforts, both oral and written, to minority, female and community organizations, to schools with minority and female students and to minority and female recruitment and training organizations serving the Contractor's recruitment area and employment needs. Not later than one month prior to the date for the acceptance of applications for apprenticeship or other training by any recruitment source, the Contractor shall send written notification to organizations such as the above, describing the openings, screening procedures, and tests to be used in the selection process.**
- j. **Encourage present minority and female employees to recruit other minority persons**

and women and, where reasonable, provide after school, summer and vacation employment to minority and female youth both on the site and in other areas of a Contractor's workforce.

- k. **Validate all tests and other selection requirements where there is an obligation to do so under 41 CFR Part 60.3.**
  - l. **Conduct, at least annually, an inventory and evaluation at least of all minority and female personnel for promotional opportunities and encourage these employees to seek or to prepare for, through appropriate training, etc., such opportunities.**
  - m. **Ensure that seniority practices, job classifications, work assignments and other personnel practices, do not have a discriminatory effect by continually monitoring all personnel and employment related activities to ensure that the EEO policy and the Contractor's obligations under these specifications are being carried out.**
  - n. **Ensure that all facilities and company activities are nonsegregated except that separate or single-user toilet and necessary changing facilities shall be provided to assure privacy between the sexes.**
  - o. **Document and maintain a record of all solicitations of offers for subcontracts from minority and female construction contractors and suppliers, including circulation of solicitations to minority and female contractor associations and other business associations.**
  - p. **Conduct a review, at least annually, of all supervisors' adherence to and performance under the Contractor's EEO policies and affirmative action obligations.**
8. **Contractors are encouraged to participate in voluntary associations which assist in fulfilling one or more of their affirmative action obligations (7a through p). The efforts of a contractor association, joint contractor-union, contractor-community, or other similar group of which the contractor is a member and participant, may be asserted as fulfilling any one or more of its obligations under 7a through p of these Specifications provided that the contractor actively participates in the group, makes every effort to assure that the group has a positive impact on the employment of minorities and women in the industry, ensures that the concrete benefits of the program are reflected in the Contractor's minority and female workforce participation, makes a good faith effort to meet its individual goals and timetable, and can provide access to documentation which demonstrates the effectiveness of actions taken on behalf of the Contractor. The obligation to comply, however, is the Contractor's and failure of such a group to fulfill an obligation shall not be a defense for the Contractor's noncompliance.**
9. **A single goal for minorities and separate single goal for women have been established. The Contractor, however, is required to provide equal employment opportunity and to take affirmative action for all minority groups, both male and female, and all women, both minority and non-minority. Consequently, the Contractor may be in violation of the Executive Order if a particular group is employed in a substantially disparate manner (for example, even though the Contractor has achieved its goals for women generally, the Contractor may be in violation of the Executive Order if a specific minority group of women is underutilized).**
10. **The Contractor shall not use the goals and timetables or affirmative action standards to discriminate against any person because of race, color, religion, sex, or national origin.**

11. The Contractor shall not enter into any subcontract with any person or firm debarred from Government contracts pursuant to Executive Order 11246.
12. The Contractor shall carry out such sanctions and penalties for violation of these specifications and of the Equal Opportunity Clause, including suspension, termination and cancellation of existing subcontracts as may be imposed or ordered pursuant to Executive Order 11246, as amended, and its implementing regulations, by the Office of Federal Contract Compliance Programs. Any Contractor who fails to carry out such sanctions and penalties shall be in violation of these specifications and Executive Order 11246, as amended.
13. The Contractor, in fulfilling its obligations under these specifications, shall implement specific affirmative action steps, at least as extensive as those standards prescribed in paragraph 7 of these specifications, so as to achieve maximum results from its efforts to ensure equal employment opportunity. If the Contractor fails to comply with the requirements of the Executive Order, the implementing regulations, or these specifications, the Director shall proceed in accordance with 41 CFR 60-4.8.
14. The Contractor shall designate a responsible official to monitor all employment related activity to ensure that the company EEO policy is being carried out, to submit reports relating to the provisions hereof as may be required by the Government and to keep records. Records shall at least include for each employee the name, address, telephone numbers, construction trade, union affiliation if any, employee identification number when assigned, social security number, race, sex, status (e.g. mechanic, apprentice, trainee, helper, or laborer), dates of changes in status, hours worked per week in the indicated trade, rate of pay, and locations at which the work was performed. Records shall be maintained in an easily understandable and retrievable form; however, to the degree that existing records satisfy this requirement, contractors shall not be required to maintain separate records.
15. Nothing herein provided shall be construed as a limitation upon the application of other laws which establish different standards of compliance or upon the application of requirements for the hiring of local or other area residents (e.g. those under the Public Works Employment Act of 1977 and the Community Development Block Grant Program).

**Detroit Area Office**

Christopher Edwards, Area Office Director  
 U.S. DOL/ESA/OFCCP  
 Detroit Area Office  
 211 West Fort Street  
 Detroit, Michigan 48226  
 Phone: 313/226-3728

**Michigan Counties:**

|         |            |          |                |           |            |
|---------|------------|----------|----------------|-----------|------------|
| Alcona  | Benzie     | Clare    | Grand Traverse | Isabella  | Lenawee    |
| Allegan | Berrien    | Clinton  | Gratiot        | Kalamazoo | Livingston |
| Alpena  | Branch     | Crawford | Hillsdale      | Kalkaska  | Macomb     |
| Antrim  | Calhoun    | Eaton    | Huron          | Kent      | Manistee   |
| Arenac  | Cass       | Emmet    | Ingham         | Lake      | Mason      |
| Barry   | Charlevoix | Genesee  | Ionia          | Lapeer    | Mecosta    |
| Bay     | Cheboygan  | Gladwin  | Iosco          | Leelanau  | Midland    |



**Michigan Counties:**

|                    |                     |                   |                  |
|--------------------|---------------------|-------------------|------------------|
| <b>Missaukee</b>   | <b>Oceana</b>       | <b>Roscommon</b>  | <b>Van Buren</b> |
| <b>Monroe</b>      | <b>Ogemaw</b>       | <b>St. Clair</b>  | <b>Washtenaw</b> |
| <b>Montcalm</b>    | <b>Osceola</b>      | <b>St. Joseph</b> | <b>Wayne</b>     |
| <b>Montmorency</b> | <b>Oscoda</b>       | <b>Saginaw</b>    | <b>Wexford</b>   |
| <b>Muskegon</b>    | <b>Otsego</b>       | <b>Sanilac</b>    |                  |
| <b>Newaygo</b>     | <b>Ottawa</b>       | <b>Shiawassee</b> |                  |
| <b>Oakland</b>     | <b>Presque Isle</b> | <b>Tuscola</b>    |                  |

**Milwaukee Area Office**

**Mr. Robert Potter**  
**U.S. DOL/ESA/OFCCP**  
**Milwaukee Area Office**  
**Reuss Federal Bldg., Room 1115**  
**310 West Wisconsin**  
**Milwaukee, Wisconsin 53203**  
**Phone: 414/291-3822**

**Michigan Counties:**

|                 |                  |                 |                  |                    |
|-----------------|------------------|-----------------|------------------|--------------------|
| <b>Alger</b>    | <b>Delta</b>     | <b>Houghton</b> | <b>Luce</b>      | <b>Menominee</b>   |
| <b>Baraga</b>   | <b>Dickinson</b> | <b>Iron</b>     | <b>Mackinac</b>  | <b>Ontonagon</b>   |
| <b>Chippewa</b> | <b>Gogebic</b>   | <b>Keweenaw</b> | <b>Marquette</b> | <b>Schoolcraft</b> |

## Appendix A to Subpart A of Part 230—Special Provisions

### Specific Equal Employment Opportunity Responsibilities

1. *General.* a. Equal employment opportunity requirements not to discriminate and to take affirmative action to assure equal employment opportunity as required by Executive Order 11246 and Executive Order 11375 are set forth in Required Contract, Provisions (Form PR-1273 or 1316, as appropriate) and these Special Provisions which are imposed pursuant to section 140 of title 23 U.S.C., as established by section 22 of the Federal-Aid Highway Act of 1968. The requirements set forth in these Special Provisions shall constitute the specific affirmative action requirements for project activities under this contract and supplement the equal employment opportunity requirements set forth in the Required Contract Provisions.

b. The contractor will work with the State highway agencies and the Federal Government in carrying out equal employment opportunity obligations and in their review of his/her activities under the contract.

c. The contractor and all his/her subcontractors holding subcontracts not including material suppliers, of \$10,000 or more, will comply with the following minimum specific requirement activities of equal employment opportunity: (The equal employment opportunity requirements of Executive Order 11246, as set forth in volume 6, chapter 4, section 1, subsection 1 of the Federal-Aid Highway Program Manual, are applicable to material suppliers as well as contractors and subcontractors.) The contractor will include these requirements in every subcontract of \$10,000 or more with such modification of language as is necessary to make them binding on the subcontractor.

2. *Equal Employment Opportunity Policy.* The contractor will accept as his operating policy the following statement which is designed to further the provision of equal employment opportunity to all persons without regard to their race, color, religion, sex, or national origin, and to promote the full realization of equal employment opportunity through a positive continuing program:

It is the policy of this Company to assure that applicants are employed, and that employees are treated during employment, without regard to their race, religion, sex, color, or national origin. Such action shall include: employment, upgrading, demotion, or transfer; recruitment or recruitment advertising; layoff or termination; rates of pay or other forms of compensation; and selection for training, including apprenticeship, pre-apprenticeship, and/or on-the-job training.

3. *Equal Employment Opportunity Officer.* The contractor will designate and make known to the State highway agency contracting officers and equal employment opportunity officer (hereinafter referred to as the EEO Officer) who will have the responsibility for and must be capable of effectively administering and promoting an active contractor program of equal employment opportunity and who must be assigned adequate authority and responsibility to do so.

4. *Dissemination of Policy.* a. All members of the contractor's staff who are authorized to hire, supervise, promote, and discharge employees, or who recommend such action, or who are substantially involved in such action, will be made fully cognizant of, and will implement, the contractor's equal employment opportunity policy and contractual responsibilities to provide equal employment opportunity in each grade and classification of employment. To ensure that the above agreement will be met, the following actions will be taken as a minimum:

(1) Periodic meetings of supervisory and personnel office employees will be conducted before the start of work and then not less often than once every six months, at which time the contractor's equal employment

opportunity policy and its implementation will be reviewed and explained. The meetings will be conducted by the EEO Officer or other knowledgeable company official.

(2) All new supervisory or personnel office employees will be given a thorough indoctrination by the EEO Officer or other knowledgeable company official, covering all major aspects of the contractor's equal employment opportunity obligations within thirty days following their reporting for duty with the contractor.

(3) All personnel who are engaged in direct recruitment for the project will be instructed by the EEO Officer or appropriate company official in the contractor's procedures for locating and hiring minority group employees.

b. In order to make the contractor's equal employment opportunity policy known to all employees, prospective employees and potential sources of employees, *i.e.*, schools, employment agencies, labor unions (where appropriate), college placement officers, etc., the contractor will take the following actions:

(1) Notices and posters setting forth the contractor's equal employment opportunity policy will be placed in areas readily accessible to employees, applicants for employment and potential employees.

(2) The contractor's equal employment opportunity policy and the procedures to implement such policy will be brought to the attention of employees by means of meetings, employee handbooks, or other appropriate means.

5. Recruitment. a. When advertising for employees, the contractor will include in all advertisements for employees the notation: "An Equal Opportunity Employer." All such advertisements will be published in newspapers or other publications having a large circulation among minority groups in the area from which the project work force would normally be derived.

b. The contractor will, unless precluded by a valid bargaining agreement, conduct systematic and direct recruitment through public and private employee referral sources likely to yield qualified minority group applicants, including, but not limited to, State employment agencies, schools, colleges and minority group organizations. To meet this requirement, the contractor will, through his EEO Officer, identify sources of potential minority group employees, and establish with such identified sources procedures whereby minority group applicants may be referred to the contractor for employment consideration.

In the event the contractor has a valid bargaining agreement providing for exclusive hiring hall referrals, he is expected to observe the provisions of that agreement to the extent that the system permits the contractor's compliance with equal employment opportunity contract provisions. (The U.S. Department of Labor has held that where implementation of such agreements have the effect of discriminating against minorities or women, or obligates the contractor to do the same, such implementation violates Executive Order 11246, as amended.)

c. The contractor will encourage his present employees to refer minority group applicants for employment by posting appropriate notices or bulletins in areas accessible to all such employees. In addition, information and procedures with regard to referring minority group applicants will be discussed with employees.

6. *Personnel Actions.* Wages, working conditions, and employee benefits shall be established and administered, and personnel actions of every type, including hiring, upgrading, promotion, transfer, demotion, layoff, and termination, shall be taken without regard to race, color, religion, sex, or national origin. The following procedures shall be followed:

- a. The contractor will conduct periodic inspections of project sites to insure that working conditions and employee facilities do not indicate discriminatory treatment of project site personnel.
- b. The contractor will periodically evaluate the spread of wages paid within each classification to determine any evidence of discriminatory wage practices.
- c. The contractor will periodically review selected personnel actions in depth to determine whether there is evidence of discrimination. Where evidence is found, the contractor will promptly take corrective action. If the review indicates that the discrimination may extend beyond the actions reviewed, such corrective action shall include all affected persons.
- d. The contractor will promptly investigate all complaints of alleged discrimination made to the contractor in connection with his obligations under this contract, will attempt to resolve such complaints, and will take appropriate corrective action within a reasonable time. If the investigation indicates that the discrimination may affect persons other than the complainant, such corrective action shall include such other persons. Upon completion of each investigation, the contractor will inform every complainant of all of his avenues of appeal.

**7. Training and Promotion.** a. The contractor will assist in locating, qualifying, and increasing the skills of minority group and women employees, and applicants for employment.

b. Consistent with the contractor's work force requirements and as permissible under Federal and State regulations, the contractor shall make full use of training programs, *i.e.*, apprenticeship, and on-the-job training programs for the geographical area of contract performance. Where feasible, 25 percent of apprentices or trainees in each occupation shall be in their first year of apprenticeship or training. In the event the Training Special Provision is provided under this contract, this subparagraph will be superseded as indicated in Attachment 2.

c. The contractor will advise employees and applicants for employment of available training programs and entrance requirements for each.

d. The contractor will periodically review the training and promotion potential of minority group and women employees and will encourage eligible employees to apply for such training and promotion.

**8. Unions.** If the contractor relies in whole or in part upon unions as a source of employees, the contractor will use his/her best efforts to obtain the cooperation of such unions to increase opportunities for minority groups and women within the unions, and to effect referrals by such unions of minority and female employees. Actions by the contractor either directly or through a contractor's association acting as agent will include the procedures set forth below:

a. The contractor will use best efforts to develop, in cooperation with the unions, joint training programs aimed toward qualifying more minority group members and women for membership in the unions and increasing the skills of minority group employees and women so that they may qualify for higher paying employment.

b. The contractor will use best efforts to incorporate an equal employment opportunity clause into each union agreement to the end that such union will be contractually bound to refer applicants without regard to their race, color, religion, sex, or national origin.

c. The contractor is to obtain information as to the referral practices and policies of the labor union except that to the extent such information is within the exclusive possession of the labor union and such labor

union refuses to furnish such information to the contractor, the contractor shall so certify to the State highway department and shall set forth what efforts have been made to obtain such information.

d. In the event the union is unable to provide the contractor with a reasonable flow of minority and women referrals within the time limit set forth in the collective bargaining agreement, the contractor will, through independent recruitment efforts, fill the employment vacancies without regard to race, color, religion, sex, or national origin; making full efforts to obtain qualified and/or qualifiable minority group persons and women. (The U.S. Department of Labor has held that it shall be no excuse that the union with which the contractor has a collective bargaining agreement providing for exclusive referral failed to refer minority employees.) In the event the union referral practice prevents the contractor from meeting the obligations pursuant to Executive Order 11246, as amended, and these special provisions, such contractor shall immediately notify the State highway agency.

9. *Subcontracting.* a. The contractor will use his best efforts to solicit bids from and to utilize minority group subcontractors or subcontractors with meaningful minority group and female representation among their employees. Contractors shall obtain lists of minority-owned construction firms from State highway agency personnel.

b. The contractor will use his best efforts to ensure subcontractor compliance with their equal employment opportunity obligations.

10. *Records and Reports.* a. The contractor will keep such records as are necessary to determine compliance with the contractor's equal employment opportunity obligations. The records kept by the contractor will be designed to indicate:

- (1) The number of minority and nonminority group members and women employed in each work classification on the project.
- (2) The progress and efforts being made in cooperation with unions to increase employment opportunities for minorities and women (applicable only to contractors who rely in whole or in part on unions as a source of their work force),
- (3) The progress and efforts being made in locating, hiring, training, qualifying, and upgrading minority and female employees, and
- (4) The progress and efforts being made in securing the services of minority group subcontractors or subcontractors with meaningful minority and female representation among their employees.

b. All such records must be retained for a period of three years following completion of the contract work and shall be available at reasonable times and places for inspection by authorized representatives of the State highway agency and the Federal Highway Administration.

c. The contractors will submit an annual report to the State highway agency each July for the duration of the project, indicating the number of minority, women, and non-minority group employees currently engaged in each work classification required by the contract work. This information is to be reported on Form PR 1391. If on-the-job training is being required by "Training Special Provision", the contractor will be required to furnish Form FHWA 1409.

[40 FR 28053, July 3, 1975, as amended at 43 FR 19386, May 5, 1978. Correctly redesignated at 46 FR 21156, Apr. 9, 1981]

**REQUIRED CONTRACT PROVISIONS  
FEDERAL-AID CONSTRUCTION CONTRACTS**

- I. General
- II. Nondiscrimination
- III. Nonsegregated Facilities
- IV. Davis-Bacon and Related Act Provisions
- V. Contract Work Hours and Safety Standards Act Provisions
- VI. Subletting or Assigning the Contract
- VII. Safety: Accident Prevention
- VIII. False Statements Concerning Highway Projects
- IX. Implementation of Clean Air Act and Federal Water Pollution Control Act
- X. Compliance with Governmentwide Suspension and Debarment Requirements
- XI. Certification Regarding Use of Contract Funds for Lobbying

**ATTACHMENTS**

A. Employment and Materials Preference for Appalachian Development Highway System or Appalachian Local Access Road Contracts (included in Appalachian contracts only)

**I. GENERAL**

1. Form FHWA-1273 must be physically incorporated in each construction contract funded under Title 23 (excluding emergency contracts solely intended for debris removal). The contractor (or subcontractor) must insert this form in each subcontract and further require its inclusion in all lower tier subcontracts (excluding purchase orders, rental agreements and other agreements for supplies or services).

The applicable requirements of Form FHWA-1273 are incorporated by reference for work done under any purchase order, rental agreement or agreement for other services. The prime contractor shall be responsible for compliance by any subcontractor, lower-tier subcontractor or service provider.

Form FHWA-1273 must be included in all Federal-aid design-build contracts, in all subcontracts and in lower tier subcontracts (excluding subcontracts for design services, purchase orders, rental agreements and other agreements for supplies or services). The design-builder shall be responsible for compliance by any subcontractor, lower-tier subcontractor or service provider.

Contracting agencies may reference Form FHWA-1273 in bid proposal or request for proposal documents, however, the Form FHWA-1273 must be physically incorporated (not referenced) in all contracts, subcontracts and lower-tier subcontracts (excluding purchase orders, rental agreements and other agreements for supplies or services related to a construction contract).

2. Subject to the applicability criteria noted in the following sections, these contract provisions shall apply to all work performed on the contract by the contractor's own organization and with the assistance of workers under the contractor's immediate superintendence and to all work performed on the contract by piecework, station work, or by subcontract.

3. A breach of any of the stipulations contained in these Required Contract Provisions may be sufficient grounds for withholding of progress payments, withholding of final payment, termination of the contract, suspension / debarment or any other action determined to be appropriate by the contracting agency and FHWA.

4. Selection of Labor: During the performance of this contract, the contractor shall not use convict labor for any purpose within the limits of a construction project on a Federal-aid highway unless it is labor performed by convicts who are on parole, supervised release, or probation. The term Federal-aid highway does not include roadways functionally classified as local roads or rural minor collectors.

**II. NONDISCRIMINATION**

The provisions of this section related to 23 CFR Part 230 are applicable to all Federal-aid construction contracts and to all related construction subcontracts of \$10,000 or more. The provisions of 23 CFR Part 230 are not applicable to material supply, engineering, or architectural service contracts.

In addition, the contractor and all subcontractors must comply with the following policies: Executive Order 11246, 41 CFR 60, 29 CFR 1625-1627, Title 23 USC Section 140, the Rehabilitation Act of 1973, as amended (29 USC 794), Title VI of the Civil Rights Act of 1964, as amended, and related regulations including 49 CFR Parts 21, 26 and 27; and 23 CFR Parts 200, 230, and 633.

The contractor and all subcontractors must comply with: the requirements of the Equal Opportunity Clause in 41 CFR 60-1.4(b) and, for all construction contracts exceeding \$10,000, the Standard Federal Equal Employment Opportunity Construction Contract Specifications in 41 CFR 60-4.3.

Note: The U.S. Department of Labor has exclusive authority to determine compliance with Executive Order 11246 and the policies of the Secretary of Labor including 41 CFR 60, and 29 CFR 1625-1627. The contracting agency and the FHWA have the authority and the responsibility to ensure compliance with Title 23 USC Section 140, the Rehabilitation Act of 1973, as amended (29 USC 794), and Title VI of the Civil Rights Act of 1964, as amended, and related regulations including 49 CFR Parts 21, 26 and 27; and 23 CFR Parts 200, 230, and 633.

The following provision is adopted from 23 CFR 230, Appendix A, with appropriate revisions to conform to the U.S. Department of Labor (US DOL) and FHWA requirements.

**1. Equal Employment Opportunity:** Equal employment opportunity (EEO) requirements not to discriminate and to take affirmative action to assure equal opportunity as set forth under laws, executive orders, rules, regulations (28 CFR 35, 29 CFR 1630, 29 CFR 1625-1627, 41 CFR 60 and 49 CFR 27) and orders of the Secretary of Labor as modified by the provisions prescribed herein, and imposed pursuant to 23 U.S.C. 140 shall constitute the EEO and specific affirmative action standards for the contractor's project activities under

this contract. The provisions of the Americans with Disabilities Act of 1990 (42 U.S.C. 12101 et seq.) set forth under 28 CFR 35 and 29 CFR 1630 are incorporated by reference in this contract. In the execution of this contract, the contractor agrees to comply with the following minimum specific requirement activities of EEO:

a. The contractor will work with the contracting agency and the Federal Government to ensure that it has made every good faith effort to provide equal opportunity with respect to all of its terms and conditions of employment and in their review of activities under the contract.

b. The contractor will accept as its operating policy the following statement:

"It is the policy of this Company to assure that applicants are employed, and that employees are treated during employment, without regard to their race, religion, sex, color, national origin, age or disability. Such action shall include: employment, upgrading, demotion, or transfer; recruitment or recruitment advertising; layoff or termination; rates of pay or other forms of compensation; and selection for training, including apprenticeship, pre-apprenticeship, and/or on-the-job training."

**2. EEO Officer:** The contractor will designate and make known to the contracting officers an EEO Officer who will have the responsibility for and must be capable of effectively administering and promoting an active EEO program and who must be assigned adequate authority and responsibility to do so.

**3. Dissemination of Policy:** All members of the contractor's staff who are authorized to hire, supervise, promote, and discharge employees, or who recommend such action, or who are substantially involved in such action, will be made fully cognizant of, and will implement, the contractor's EEO policy and contractual responsibilities to provide EEO in each grade and classification of employment. To ensure that the above agreement will be met, the following actions will be taken as a minimum:

a. Periodic meetings of supervisory and personnel office employees will be conducted before the start of work and then not less often than once every six months, at which time the contractor's EEO policy and its implementation will be reviewed and explained. The meetings will be conducted by the EEO Officer.

b. All new supervisory or personnel office employees will be given a thorough indoctrination by the EEO Officer, covering all major aspects of the contractor's EEO obligations within thirty days following their reporting for duty with the contractor.

c. All personnel who are engaged in direct recruitment for the project will be instructed by the EEO Officer in the contractor's procedures for locating and hiring minorities and women.

d. Notices and posters setting forth the contractor's EEO policy will be placed in areas readily accessible to employees, applicants for employment and potential employees.

e. The contractor's EEO policy and the procedures to implement such policy will be brought to the attention of employees by means of meetings, employee handbooks, or other appropriate means.

**4. Recruitment:** When advertising for employees, the contractor will include in all advertisements for employees the notation: "An Equal Opportunity Employer." All such advertisements will be placed in publications having a large circulation among minorities and women in the area from which the project work force would normally be derived.

a. The contractor will, unless precluded by a valid bargaining agreement, conduct systematic and direct recruitment through public and private employee referral sources likely to yield qualified minorities and women. To meet this requirement, the contractor will identify sources of potential minority group employees, and establish with such identified sources procedures whereby minority and women applicants may be referred to the contractor for employment consideration.

b. In the event the contractor has a valid bargaining agreement providing for exclusive hiring hall referrals, the contractor is expected to observe the provisions of that agreement to the extent that the system meets the contractor's compliance with EEO contract provisions. Where implementation of such an agreement has the effect of discriminating against minorities or women, or obligates the contractor to do the same, such implementation violates Federal nondiscrimination provisions.

c. The contractor will encourage its present employees to refer minorities and women as applicants for employment. Information and procedures with regard to referring such applicants will be discussed with employees.

**5. Personnel Actions:** Wages, working conditions, and employee benefits shall be established and administered, and personnel actions of every type, including hiring, upgrading, promotion, transfer, demotion, layoff, and termination, shall be taken without regard to race, color, religion, sex, national origin, age or disability. The following procedures shall be followed:

a. The contractor will conduct periodic inspections of project sites to insure that working conditions and employee facilities do not indicate discriminatory treatment of project site personnel.

b. The contractor will periodically evaluate the spread of wages paid within each classification to determine any evidence of discriminatory wage practices.

c. The contractor will periodically review selected personnel actions in depth to determine whether there is evidence of discrimination. Where evidence is found, the contractor will promptly take corrective action. If the review indicates that the discrimination may extend beyond the actions reviewed, such corrective action shall include all affected persons.

d. The contractor will promptly investigate all complaints of alleged discrimination made to the contractor in connection with its obligations under this contract, will attempt to resolve such complaints, and will take appropriate corrective action within a reasonable time. If the investigation indicates that the discrimination may affect persons other than the complainant, such corrective action shall include such other persons. Upon completion of each investigation, the contractor will inform every complainant of all of their avenues of appeal.

**6. Training and Promotion:**

a. The contractor will assist in locating, qualifying, and increasing the skills of minorities and women who are



applicants for employment or current employees. Such efforts should be aimed at developing full journey level status employees in the type of trade or job classification involved.

b. Consistent with the contractor's work force requirements and as permissible under Federal and State regulations, the contractor shall make full use of training programs, i.e., apprenticeship, and on-the-job training programs for the geographical area of contract performance. In the event a special provision for training is provided under this contract, this subparagraph will be superseded as indicated in the special provision. The contracting agency may reserve training positions for persons who receive welfare assistance in accordance with 23 U.S.C. 140(a).

c. The contractor will advise employees and applicants for employment of available training programs and entrance requirements for each.

d. The contractor will periodically review the training and promotion potential of employees who are minorities and women and will encourage eligible employees to apply for such training and promotion.

**7. Unions:** If the contractor relies in whole or in part upon unions as a source of employees, the contractor will use good faith efforts to obtain the cooperation of such unions to increase opportunities for minorities and women. Actions by the contractor, either directly or through a contractor's association acting as agent, will include the procedures set forth below:

a. The contractor will use good faith efforts to develop, in cooperation with the unions, joint training programs aimed toward qualifying more minorities and women for membership in the unions and increasing the skills of minorities and women so that they may qualify for higher paying employment.

b. The contractor will use good faith efforts to incorporate an EEO clause into each union agreement to the end that such union will be contractually bound to refer applicants without regard to their race, color, religion, sex, national origin, age or disability.

c. The contractor is to obtain information as to the referral practices and policies of the labor union except that to the extent such information is within the exclusive possession of the labor union and such labor union refuses to furnish such information to the contractor, the contractor shall so certify to the contracting agency and shall set forth what efforts have been made to obtain such information.

d. In the event the union is unable to provide the contractor with a reasonable flow of referrals within the time limit set forth in the collective bargaining agreement, the contractor will, through independent recruitment efforts, fill the employment vacancies without regard to race, color, religion, sex, national origin, age or disability; making full efforts to obtain qualified and/or qualifiable minorities and women. The failure of a union to provide sufficient referrals (even though it is obligated to provide exclusive referrals under the terms of a collective bargaining agreement) does not relieve the contractor from the requirements of this paragraph. In the event the union referral practice prevents the contractor from meeting the obligations pursuant to Executive Order 11246, as amended, and these special provisions, such contractor shall immediately notify the contracting agency.

**8. Reasonable Accommodation for Applicants / Employees with Disabilities:** The contractor must be familiar

with the requirements for and comply with the Americans with Disabilities Act and all rules and regulations established there under. Employers must provide reasonable accommodation in all employment activities unless to do so would cause an undue hardship.

**9. Selection of Subcontractors, Procurement of Materials and Leasing of Equipment:** The contractor shall not discriminate on the grounds of race, color, religion, sex, national origin, age or disability in the selection and retention of subcontractors, including procurement of materials and leases of equipment. The contractor shall take all necessary and reasonable steps to ensure nondiscrimination in the administration of this contract.

a. The contractor shall notify all potential subcontractors and suppliers and lessors of their EEO obligations under this contract.

b. The contractor will use good faith efforts to ensure subcontractor compliance with their EEO obligations.

**10. Assurance Required by 49 CFR 26.13(b):**

a. The requirements of 49 CFR Part 26 and the State DOT's U.S. DOT-approved DBE program are incorporated by reference.

b. The contractor or subcontractor shall not discriminate on the basis of race, color, national origin, or sex in the performance of this contract. The contractor shall carry out applicable requirements of 49 CFR Part 26 in the award and administration of DOT-assisted contracts. Failure by the contractor to carry out these requirements is a material breach of this contract, which may result in the termination of this contract or such other remedy as the contracting agency deems appropriate.

**11. Records and Reports:** The contractor shall keep such records as necessary to document compliance with the EEO requirements. Such records shall be retained for a period of three years following the date of the final payment to the contractor for all contract work and shall be available at reasonable times and places for inspection by authorized representatives of the contracting agency and the FHWA.

a. The records kept by the contractor shall document the following:

(1) The number and work hours of minority and non-minority group members and women employed in each work classification on the project;

(2) The progress and efforts being made in cooperation with unions, when applicable, to increase employment opportunities for minorities and women; and

(3) The progress and efforts being made in locating, hiring, training, qualifying, and upgrading minorities and women;

b. The contractors and subcontractors will submit an annual report to the contracting agency each July for the duration of the project, indicating the number of minority, women, and non-minority group employees currently engaged in each work classification required by the contract work. This information is to be reported on Form FHWA-1391. The staffing data should represent the project work force on board in all or any part of the last payroll period preceding the end of July. If on-the-job training is being required by special provision, the contractor



will be required to collect and report training data. The employment data should reflect the work force on board during all or any part of the last payroll period preceding the end of July.

### III. NONSEGREGATED FACILITIES

This provision is applicable to all Federal-aid construction contracts and to all related construction subcontracts of \$10,000 or more.

The contractor must ensure that facilities provided for employees are provided in such a manner that segregation on the basis of race, color, religion, sex, or national origin cannot result. The contractor may neither require such segregated use by written or oral policies nor tolerate such use by employee custom. The contractor's obligation extends further to ensure that its employees are not assigned to perform their services at any location, under the contractor's control, where the facilities are segregated. The term "facilities" includes waiting rooms, work areas, restaurants and other eating areas, time clocks, restrooms, washrooms, locker rooms, and other storage or dressing areas, parking lots, drinking fountains, recreation or entertainment areas, transportation, and housing provided for employees. The contractor shall provide separate or single-user restrooms and necessary dressing or sleeping areas to assure privacy between sexes.

### IV. DAVIS-BACON AND RELATED ACT PROVISIONS

This section is applicable to all Federal-aid construction projects exceeding \$2,000 and to all related subcontracts and lower-tier subcontracts (regardless of subcontract size). The requirements apply to all projects located within the right-of-way of a roadway that is functionally classified as Federal-aid highway. This excludes roadways functionally classified as local roads or rural minor collectors, which are exempt. Contracting agencies may elect to apply these requirements to other projects.

The following provisions are from the U.S. Department of Labor regulations in 29 CFR 5.5 "Contract provisions and related matters" with minor revisions to conform to the FHWA-1273 format and FHWA program requirements.

#### 1. Minimum wages

a. All laborers and mechanics employed or working upon the site of the work, will be paid unconditionally and not less often than once a week, and without subsequent deduction or rebate on any account (except such payroll deductions as are permitted by regulations issued by the Secretary of Labor under the Copeland Act (29 CFR part 3)), the full amount of wages and bona fide fringe benefits (or cash equivalents thereof) due at time of payment computed at rates not less than those contained in the wage determination of the Secretary of Labor which is attached hereto and made a part hereof, regardless of any contractual relationship which may be alleged to exist between the contractor and such laborers and mechanics.

Contributions made or costs reasonably anticipated for bona fide fringe benefits under section 1(b)(2) of the Davis-Bacon Act on behalf of laborers or mechanics are considered wages paid to such laborers or mechanics, subject to the provisions

of paragraph 1.d. of this section; also, regular contributions made or costs incurred for more than a weekly period (but not less often than quarterly) under plans, funds, or programs which cover the particular weekly period, are deemed to be constructively made or incurred during such weekly period. Such laborers and mechanics shall be paid the appropriate wage rate and fringe benefits on the wage determination for the classification of work actually performed, without regard to skill, except as provided in 29 CFR 5.5(a)(4). Laborers or mechanics performing work in more than one classification may be compensated at the rate specified for each classification for the time actually worked therein: Provided, That the employer's payroll records accurately set forth the time spent in each classification in which work is performed. The wage determination (including any additional classification and wage rates conformed under paragraph 1.b. of this section) and the Davis-Bacon poster (WH-1321) shall be posted at all times by the contractor and its subcontractors at the site of the work in a prominent and accessible place where it can be easily seen by the workers.

b.(1) The contracting officer shall require that any class of laborers or mechanics, including helpers, which is not listed in the wage determination and which is to be employed under the contract shall be classified in conformance with the wage determination. The contracting officer shall approve an additional classification and wage rate and fringe benefits therefore only when the following criteria have been met:

(i) The work to be performed by the classification requested is not performed by a classification in the wage determination; and

(ii) The classification is utilized in the area by the construction industry; and

(iii) The proposed wage rate, including any bona fide fringe benefits, bears a reasonable relationship to the wage rates contained in the wage determination.

(2) If the contractor and the laborers and mechanics to be employed in the classification (if known), or their representatives, and the contracting officer agree on the classification and wage rate (including the amount designated for fringe benefits where appropriate), a report of the action taken shall be sent by the contracting officer to the Administrator of the Wage and Hour Division, Employment Standards Administration, U.S. Department of Labor, Washington, DC 20210. The Administrator, or an authorized representative, will approve, modify, or disapprove every additional classification action within 30 days of receipt and so advise the contracting officer or will notify the contracting officer within the 30-day period that additional time is necessary.

(3) In the event the contractor, the laborers or mechanics to be employed in the classification or their representatives, and the contracting officer do not agree on the proposed classification and wage rate (including the amount designated for fringe benefits, where appropriate), the contracting officer shall refer the questions, including the views of all interested parties and the recommendation of the contracting officer, to the Wage and Hour Administrator for determination. The Wage and Hour Administrator, or an authorized representative, will issue a determination within 30 days of receipt and so advise the contracting officer or

will notify the contracting officer within the 30-day period that additional time is necessary.

(4) The wage rate (including fringe benefits where appropriate) determined pursuant to paragraphs 1.b.(2) or 1.b.(3) of this section, shall be paid to all workers performing work in the classification under this contract from the first day on which work is performed in the classification.

c. Whenever the minimum wage rate prescribed in the contract for a class of laborers or mechanics includes a fringe benefit which is not expressed as an hourly rate, the contractor shall either pay the benefit as stated in the wage determination or shall pay another bona fide fringe benefit or an hourly cash equivalent thereof.

d. If the contractor does not make payments to a trustee or other third person, the contractor may consider as part of the wages of any laborer or mechanic the amount of any costs reasonably anticipated in providing bona fide fringe benefits under a plan or program, Provided, That the Secretary of Labor has found, upon the written request of the contractor, that the applicable standards of the Davis-Bacon Act have been met. The Secretary of Labor may require the contractor to set aside in a separate account assets for the meeting of obligations under the plan or program.

## 2. Withholding

The contracting agency shall upon its own action or upon written request of an authorized representative of the Department of Labor, withhold or cause to be withheld from the contractor under this contract, or any other Federal contract with the same prime contractor, or any other federally-assisted contract subject to Davis-Bacon prevailing wage requirements, which is held by the same prime contractor, so much of the accrued payments or advances as may be considered necessary to pay laborers and mechanics, including apprentices, trainees, and helpers, employed by the contractor or any subcontractor the full amount of wages required by the contract. In the event of failure to pay any laborer or mechanic, including any apprentice, trainee, or helper, employed or working on the site of the work, all or part of the wages required by the contract, the contracting agency may, after written notice to the contractor, take such action as may be necessary to cause the suspension of any further payment, advance, or guarantee of funds until such violations have ceased.

## 3. Payrolls and basic records

a. Payrolls and basic records relating thereto shall be maintained by the contractor during the course of the work and preserved for a period of three years thereafter for all laborers and mechanics working at the site of the work. Such records shall contain the name, address, and social security number of each such worker, his or her correct classification, hourly rates of wages paid (including rates of contributions or costs anticipated for bona fide fringe benefits or cash equivalents thereof of the types described in section 1(b)(2)(B) of the Davis-Bacon Act), daily and weekly number of hours worked, deductions made and actual wages paid. Whenever the Secretary of Labor has found under 29 CFR 5.5(a)(1)(iv) that the wages of any laborer or mechanic include the amount of any costs reasonably anticipated in providing benefits under a plan or program described in section 1(b)(2)(B) of the Davis-

Bacon Act, the contractor shall maintain records which show that the commitment to provide such benefits is enforceable, that the plan or program is financially responsible, and that the plan or program has been communicated in writing to the laborers or mechanics affected, and records which show the costs anticipated or the actual cost incurred in providing such benefits. Contractors employing apprentices or trainees under approved programs shall maintain written evidence of the registration of apprenticeship programs and certification of trainee programs, the registration of the apprentices and trainees, and the ratios and wage rates prescribed in the applicable programs.

b.(1) The contractor shall submit weekly for each week in which any contract work is performed a copy of all payrolls to the contracting agency. The payrolls submitted shall set out accurately and completely all of the information required to be maintained under 29 CFR 5.5(a)(3)(i), except that full social security numbers and home addresses shall not be included on weekly transmittals. Instead the payrolls shall only need to include an individually identifying number for each employee ( e.g. , the last four digits of the employee's social security number). The required weekly payroll information may be submitted in any form desired. Optional Form WH-347 is available for this purpose from the Wage and Hour Division Web site at <http://www.dol.gov/esa/whd/forms/wh347instr.htm> or its successor site. The prime contractor is responsible for the submission of copies of payrolls by all subcontractors. Contractors and subcontractors shall maintain the full social security number and current address of each covered worker, and shall provide them upon request to the contracting agency for transmission to the State DOT, the FHWA or the Wage and Hour Division of the Department of Labor for purposes of an investigation or audit of compliance with prevailing wage requirements. It is not a violation of this section for a prime contractor to require a subcontractor to provide addresses and social security numbers to the prime contractor for its own records, without weekly submission to the contracting agency..

(2) Each payroll submitted shall be accompanied by a "Statement of Compliance," signed by the contractor or subcontractor or his or her agent who pays or supervises the payment of the persons employed under the contract and shall certify the following:

(i) That the payroll for the payroll period contains the information required to be provided under §5.5 (a)(3)(ii) of Regulations, 29 CFR part 5, the appropriate information is being maintained under §5.5 (a)(3)(i) of Regulations, 29 CFR part 5, and that such information is correct and complete;

(ii) That each laborer or mechanic (including each helper, apprentice, and trainee) employed on the contract during the payroll period has been paid the full weekly wages earned, without rebate, either directly or indirectly, and that no deductions have been made either directly or indirectly from the full wages earned, other than permissible deductions as set forth in Regulations, 29 CFR part 3;

(iii) That each laborer or mechanic has been paid not less than the applicable wage rates and fringe benefits or cash equivalents for the classification of work performed, as specified in the applicable wage determination incorporated into the contract.

(3) The weekly submission of a properly executed certification set forth on the reverse side of Optional Form WH-347 shall satisfy the requirement for submission of the "Statement of Compliance" required by paragraph 3.b.(2) of this section.

(4) The falsification of any of the above certifications may subject the contractor or subcontractor to civil or criminal prosecution under section 1001 of title 18 and section 231 of title 31 of the United States Code.

c. The contractor or subcontractor shall make the records required under paragraph 3.a. of this section available for inspection, copying, or transcription by authorized representatives of the contracting agency, the State DOT, the FHWA, or the Department of Labor, and shall permit such representatives to interview employees during working hours on the job. If the contractor or subcontractor fails to submit the required records or to make them available, the FHWA may, after written notice to the contractor, the contracting agency or the State DOT, take such action as may be necessary to cause the suspension of any further payment, advance, or guarantee of funds. Furthermore, failure to submit the required records upon request or to make such records available may be grounds for debarment action pursuant to 29 CFR 5.12.

#### 4. Apprentices and trainees

##### a. Apprentices (programs of the USDOL).

Apprentices will be permitted to work at less than the predetermined rate for the work they performed when they are employed pursuant to and individually registered in a bona fide apprenticeship program registered with the U.S. Department of Labor, Employment and Training Administration, Office of Apprenticeship Training, Employer and Labor Services, or with a State Apprenticeship Agency recognized by the Office, or if a person is employed in his or her first 90 days of probationary employment as an apprentice in such an apprenticeship program, who is not individually registered in the program, but who has been certified by the Office of Apprenticeship Training, Employer and Labor Services or a State Apprenticeship Agency (where appropriate) to be eligible for probationary employment as an apprentice.

The allowable ratio of apprentices to journeymen on the job site in any craft classification shall not be greater than the ratio permitted to the contractor as to the entire work force under the registered program. Any worker listed on a payroll at an apprentice wage rate, who is not registered or otherwise employed as stated above, shall be paid not less than the applicable wage rate on the wage determination for the classification of work actually performed. In addition, any apprentice performing work on the job site in excess of the ratio permitted under the registered program shall be paid not less than the applicable wage rate on the wage determination for the work actually performed. Where a contractor is performing construction on a project in a locality other than that in which its program is registered, the ratios and wage rates (expressed in percentages of the journeyman's hourly rate) specified in the contractor's or subcontractor's registered program shall be observed.

Every apprentice must be paid at not less than the rate specified in the registered program for the apprentice's level of progress, expressed as a percentage of the journeymen hourly

rate specified in the applicable wage determination. Apprentices shall be paid fringe benefits in accordance with the provisions of the apprenticeship program. If the apprenticeship program does not specify fringe benefits, apprentices must be paid the full amount of fringe benefits listed on the wage determination for the applicable classification. If the Administrator determines that a different practice prevails for the applicable apprentice classification, fringes shall be paid in accordance with that determination.

In the event the Office of Apprenticeship Training, Employer and Labor Services, or a State Apprenticeship Agency recognized by the Office, withdraws approval of an apprenticeship program, the contractor will no longer be permitted to utilize apprentices at less than the applicable predetermined rate for the work performed until an acceptable program is approved.

##### b. Trainees (programs of the USDOL).

Except as provided in 29 CFR 5.16, trainees will not be permitted to work at less than the predetermined rate for the work performed unless they are employed pursuant to and individually registered in a program which has received prior approval, evidenced by formal certification by the U.S. Department of Labor, Employment and Training Administration.

The ratio of trainees to journeymen on the job site shall not be greater than permitted under the plan approved by the Employment and Training Administration.

Every trainee must be paid at not less than the rate specified in the approved program for the trainee's level of progress, expressed as a percentage of the journeyman hourly rate specified in the applicable wage determination. Trainees shall be paid fringe benefits in accordance with the provisions of the trainee program. If the trainee program does not mention fringe benefits, trainees shall be paid the full amount of fringe benefits listed on the wage determination unless the Administrator of the Wage and Hour Division determines that there is an apprenticeship program associated with the corresponding journeyman wage rate on the wage determination which provides for less than full fringe benefits for apprentices. Any employee listed on the payroll at a trainee rate who is not registered and participating in a training plan approved by the Employment and Training Administration shall be paid not less than the applicable wage rate on the wage determination for the classification of work actually performed. In addition, any trainee performing work on the job site in excess of the ratio permitted under the registered program shall be paid not less than the applicable wage rate on the wage determination for the work actually performed.

In the event the Employment and Training Administration withdraws approval of a training program, the contractor will no longer be permitted to utilize trainees at less than the applicable predetermined rate for the work performed until an acceptable program is approved.

c. Equal employment opportunity. The utilization of apprentices, trainees and journeymen under this part shall be in conformity with the equal employment opportunity requirements of Executive Order 11246, as amended, and 29 CFR part 30.

d. Apprentices and Trainees (programs of the U.S. DOT).

Apprentices and trainees working under apprenticeship and skill training programs which have been certified by the Secretary of Transportation as promoting EEO in connection with Federal-aid highway construction programs are not subject to the requirements of paragraph 4 of this Section IV. The straight time hourly wage rates for apprentices and trainees under such programs will be established by the particular programs. The ratio of apprentices and trainees to journeymen shall not be greater than permitted by the terms of the particular program.

**5. Compliance with Copeland Act requirements.** The contractor shall comply with the requirements of 29 CFR part 3, which are incorporated by reference in this contract.

**6. Subcontracts.** The contractor or subcontractor shall insert Form FHWA-1273 in any subcontracts and also require the subcontractors to include Form FHWA-1273 in any lower tier subcontracts. The prime contractor shall be responsible for the compliance by any subcontractor or lower tier subcontractor with all the contract clauses in 29 CFR 5.5.

**7. Contract termination: debarment.** A breach of the contract clauses in 29 CFR 5.5 may be grounds for termination of the contract, and for debarment as a contractor and a subcontractor as provided in 29 CFR 5.12.

**8. Compliance with Davis-Bacon and Related Act requirements.** All rulings and interpretations of the Davis-Bacon and Related Acts contained in 29 CFR parts 1, 3, and 5 are herein incorporated by reference in this contract.

**9. Disputes concerning labor standards.** Disputes arising out of the labor standards provisions of this contract shall not be subject to the general disputes clause of this contract. Such disputes shall be resolved in accordance with the procedures of the Department of Labor set forth in 29 CFR parts 5, 6, and 7. Disputes within the meaning of this clause include disputes between the contractor (or any of its subcontractors) and the contracting agency, the U.S. Department of Labor, or the employees or their representatives.

**10. Certification of eligibility.**

a. By entering into this contract, the contractor certifies that neither it (nor he or she) nor any person or firm who has an interest in the contractor's firm is a person or firm ineligible to be awarded Government contracts by virtue of section 3(a) of the Davis-Bacon Act or 29 CFR 5.12(a)(1).

b. No part of this contract shall be subcontracted to any person or firm ineligible for award of a Government contract by virtue of section 3(a) of the Davis-Bacon Act or 29 CFR 5.12(a)(1).

c. The penalty for making false statements is prescribed in the U.S. Criminal Code, 18 U.S.C. 1001.

**V. CONTRACT WORK HOURS AND SAFETY STANDARDS ACT**

The following clauses apply to any Federal-aid construction contract in an amount in excess of \$100,000 and subject to the overtime provisions of the Contract Work Hours and Safety Standards Act. These clauses shall be inserted in addition to the clauses required by 29 CFR 5.5(a) or 29 CFR 4.6. As used in this paragraph, the terms laborers and mechanics include watchmen and guards.

**1. Overtime requirements.** No contractor or subcontractor contracting for any part of the contract work which may require or involve the employment of laborers or mechanics shall require or permit any such laborer or mechanic in any workweek in which he or she is employed on such work to work in excess of forty hours in such workweek unless such laborer or mechanic receives compensation at a rate not less than one and one-half times the basic rate of pay for all hours worked in excess of forty hours in such workweek.

**2. Violation; liability for unpaid wages; liquidated damages.** In the event of any violation of the clause set forth in paragraph (1.) of this section, the contractor and any subcontractor responsible therefor shall be liable for the unpaid wages. In addition, such contractor and subcontractor shall be liable to the United States (in the case of work done under contract for the District of Columbia or a territory, to such District or to such territory), for liquidated damages. Such liquidated damages shall be computed with respect to each individual laborer or mechanic, including watchmen and guards, employed in violation of the clause set forth in paragraph (1.) of this section, in the sum of \$10 for each calendar day on which such individual was required or permitted to work in excess of the standard workweek of forty hours without payment of the overtime wages required by the clause set forth in paragraph (1.) of this section.

**3. Withholding for unpaid wages and liquidated damages.** The FHWA or the contracting agency shall upon its own action or upon written request of an authorized representative of the Department of Labor withhold or cause to be withheld, from any moneys payable on account of work performed by the contractor or subcontractor under any such contract or any other Federal contract with the same prime contractor, or any other federally-assisted contract subject to the Contract Work Hours and Safety Standards Act, which is held by the same prime contractor, such sums as may be determined to be necessary to satisfy any liabilities of such contractor or subcontractor for unpaid wages and liquidated damages as provided in the clause set forth in paragraph (2.) of this section.

**4. Subcontracts.** The contractor or subcontractor shall insert in any subcontracts the clauses set forth in paragraph (1.) through (4.) of this section and also a clause requiring the subcontractors to include these clauses in any lower tier subcontracts. The prime contractor shall be responsible for compliance by any subcontractor or lower tier subcontractor with the clauses set forth in paragraphs (1.) through (4.) of this section.



## VI. SUBLETTING OR ASSIGNING THE CONTRACT

This provision is applicable to all Federal-aid construction contracts on the National Highway System.

1. The contractor shall perform with its own organization contract work amounting to not less than 30 percent (or a greater percentage if specified elsewhere in the contract) of the total original contract price, excluding any specialty items designated by the contracting agency. Specialty items may be performed by subcontract and the amount of any such specialty items performed may be deducted from the total original contract price before computing the amount of work required to be performed by the contractor's own organization (23 CFR 635.116).

a. The term "perform work with its own organization" refers to workers employed or leased by the prime contractor, and equipment owned or rented by the prime contractor, with or without operators. Such term does not include employees or equipment of a subcontractor or lower tier subcontractor, agents of the prime contractor, or any other assignees. The term may include payments for the costs of hiring leased employees from an employee leasing firm meeting all relevant Federal and State regulatory requirements. Leased employees may only be included in this term if the prime contractor meets all of the following conditions:

(1) the prime contractor maintains control over the supervision of the day-to-day activities of the leased employees;

(2) the prime contractor remains responsible for the quality of the work of the leased employees;

(3) the prime contractor retains all power to accept or exclude individual employees from work on the project; and

(4) the prime contractor remains ultimately responsible for the payment of predetermined minimum wages, the submission of payrolls, statements of compliance and all other Federal regulatory requirements.

b. "Specialty Items" shall be construed to be limited to work that requires highly specialized knowledge, abilities, or equipment not ordinarily available in the type of contracting organizations qualified and expected to bid or propose on the contract as a whole and in general are to be limited to minor components of the overall contract.

2. The contract amount upon which the requirements set forth in paragraph (1) of Section VI is computed includes the cost of material and manufactured products which are to be purchased or produced by the contractor under the contract provisions.

3. The contractor shall furnish (a) a competent superintendent or supervisor who is employed by the firm, has full authority to direct performance of the work in accordance with the contract requirements, and is in charge of all construction operations (regardless of who performs the work) and (b) such other of its own organizational resources (supervision, management, and engineering services) as the contracting officer determines is necessary to assure the performance of the contract.

4. No portion of the contract shall be sublet, assigned or otherwise disposed of except with the written consent of the contracting officer, or authorized representative, and such consent when given shall not be construed to relieve the contractor of any responsibility for the fulfillment of the contract. Written consent will be given only after the contracting agency has assured that each subcontract is

evidenced in writing and that it contains all pertinent provisions and requirements of the prime contract.

5. The 30% self-performance requirement of paragraph (1) is not applicable to design-build contracts; however, contracting agencies may establish their own self-performance requirements.

## VII. SAFETY: ACCIDENT PREVENTION

This provision is applicable to all Federal-aid construction contracts and to all related subcontracts.

1. In the performance of this contract the contractor shall comply with all applicable Federal, State, and local laws governing safety, health, and sanitation (23 CFR 635). The contractor shall provide all safeguards, safety devices and protective equipment and take any other needed actions as it determines, or as the contracting officer may determine, to be reasonably necessary to protect the life and health of employees on the job and the safety of the public and to protect property in connection with the performance of the work covered by the contract.

2. It is a condition of this contract, and shall be made a condition of each subcontract, which the contractor enters into pursuant to this contract, that the contractor and any subcontractor shall not permit any employee, in performance of the contract, to work in surroundings or under conditions which are unsanitary, hazardous or dangerous to his/her health or safety, as determined under construction safety and health standards (29 CFR 1926) promulgated by the Secretary of Labor, in accordance with Section 107 of the Contract Work Hours and Safety Standards Act (40 U.S.C. 3704).

3. Pursuant to 29 CFR 1926.3, it is a condition of this contract that the Secretary of Labor or authorized representative thereof, shall have right of entry to any site of contract performance to inspect or investigate the matter of compliance with the construction safety and health standards and to carry out the duties of the Secretary under Section 107 of the Contract Work Hours and Safety Standards Act (40 U.S.C.3704).

## VIII. FALSE STATEMENTS CONCERNING HIGHWAY PROJECTS

This provision is applicable to all Federal-aid construction contracts and to all related subcontracts.

In order to assure high quality and durable construction in conformity with approved plans and specifications and a high degree of reliability on statements and representations made by engineers, contractors, suppliers, and workers on Federal-aid highway projects, it is essential that all persons concerned with the project perform their functions as carefully, thoroughly, and honestly as possible. Willful falsification, distortion, or misrepresentation with respect to any facts related to the project is a violation of Federal law. To prevent any misunderstanding regarding the seriousness of these and similar acts, Form FHWA-1022 shall be posted on each Federal-aid highway project (23 CFR 635) in one or more places where it is readily available to all persons concerned with the project:

18 U.S.C. 1020 reads as follows:

"Whoever, being an officer, agent, or employee of the United States, or of any State or Territory, or whoever, whether a person, association, firm, or corporation, knowingly makes any false statement, false representation, or false report as to the character, quality, quantity, or cost of the material used or to be used, or the quantity or quality of the work performed or to be performed, or the cost thereof in connection with the submission of plans, maps, specifications, contracts, or costs of construction on any highway or related project submitted for approval to the Secretary of Transportation; or

Whoever knowingly makes any false statement, false representation, false report or false claim with respect to the character, quality, quantity, or cost of any work performed or to be performed, or materials furnished or to be furnished, in connection with the construction of any highway or related project approved by the Secretary of Transportation; or

Whoever knowingly makes any false statement or false representation as to material fact in any statement, certificate, or report submitted pursuant to provisions of the Federal-aid Roads Act approved July 1, 1916, (39 Stat. 355), as amended and supplemented;

Shall be fined under this title or imprisoned not more than 5 years or both."

#### **IX. IMPLEMENTATION OF CLEAN AIR ACT AND FEDERAL WATER POLLUTION CONTROL ACT**

This provision is applicable to all Federal-aid construction contracts and to all related subcontracts.

By submission of this bid/proposal or the execution of this contract, or subcontract, as appropriate, the bidder, proposer, Federal-aid construction contractor, or subcontractor, as appropriate, will be deemed to have stipulated as follows:

1. That any person who is or will be utilized in the performance of this contract is not prohibited from receiving an award due to a violation of Section 508 of the Clean Water Act or Section 306 of the Clean Air Act.
2. That the contractor agrees to include or cause to be included the requirements of paragraph (1) of this Section X in every subcontract, and further agrees to take such action as the contracting agency may direct as a means of enforcing such requirements.

#### **X. CERTIFICATION REGARDING DEBARMENT, SUSPENSION, INELIGIBILITY AND VOLUNTARY EXCLUSION**

This provision is applicable to all Federal-aid construction contracts, design-build contracts, subcontracts, lower-tier subcontracts, purchase orders, lease agreements, consultant contracts or any other covered transaction requiring FHWA approval or that is estimated to cost \$25,000 or more – as defined in 2 CFR Parts 180 and 1200.

##### **1. Instructions for Certification – First Tier Participants:**

a. By signing and submitting this proposal, the prospective first tier participant is providing the certification set out below.

b. The inability of a person to provide the certification set out below will not necessarily result in denial of participation in this

covered transaction. The prospective first tier participant shall submit an explanation of why it cannot provide the certification set out below. The certification or explanation will be considered in connection with the department or agency's determination whether to enter into this transaction. However, failure of the prospective first tier participant to furnish a certification or an explanation shall disqualify such a person from participation in this transaction.

c. The certification in this clause is a material representation of fact upon which reliance was placed when the contracting agency determined to enter into this transaction. If it is later determined that the prospective participant knowingly rendered an erroneous certification, in addition to other remedies available to the Federal Government, the contracting agency may terminate this transaction for cause of default.

d. The prospective first tier participant shall provide immediate written notice to the contracting agency to whom this proposal is submitted if any time the prospective first tier participant learns that its certification was erroneous when submitted or has become erroneous by reason of changed circumstances.

e. The terms "covered transaction," "debarred," "suspended," "ineligible," "participant," "person," "principal," and "voluntarily excluded," as used in this clause, are defined in 2 CFR Parts 180 and 1200. "First Tier Covered Transactions" refers to any covered transaction between a grantee or subgrantee of Federal funds and a participant (such as the prime or general contract). "Lower Tier Covered Transactions" refers to any covered transaction under a First Tier Covered Transaction (such as subcontracts). "First Tier Participant" refers to the participant who has entered into a covered transaction with a grantee or subgrantee of Federal funds (such as the prime or general contractor). "Lower Tier Participant" refers any participant who has entered into a covered transaction with a First Tier Participant or other Lower Tier Participants (such as subcontractors and suppliers).

f. The prospective first tier participant agrees by submitting this proposal that, should the proposed covered transaction be entered into, it shall not knowingly enter into any lower tier covered transaction with a person who is debarred, suspended, declared ineligible, or voluntarily excluded from participation in this covered transaction, unless authorized by the department or agency entering into this transaction.

g. The prospective first tier participant further agrees by submitting this proposal that it will include the clause titled "Certification Regarding Debarment, Suspension, Ineligibility and Voluntary Exclusion-Lower Tier Covered Transactions," provided by the department or contracting agency, entering into this covered transaction, without modification, in all lower tier covered transactions and in all solicitations for lower tier covered transactions exceeding the \$25,000 threshold.

h. A participant in a covered transaction may rely upon a certification of a prospective participant in a lower tier covered transaction that is not debarred, suspended, ineligible, or voluntarily excluded from the covered transaction, unless it knows that the certification is erroneous. A participant is responsible for ensuring that its principals are not suspended, debarred, or otherwise ineligible to participate in covered transactions. To verify the eligibility of its principals, as well as the eligibility of any lower tier prospective participants, each participant may, but is not required to, check the Excluded Parties List System website (<https://www.epls.gov/>), which is compiled by the General Services Administration.

i. Nothing contained in the foregoing shall be construed to require the establishment of a system of records in order to render in good faith the certification required by this clause. The knowledge and information of the prospective participant is not required to exceed that which is normally possessed by a prudent person in the ordinary course of business dealings.

j. Except for transactions authorized under paragraph (f) of these instructions, if a participant in a covered transaction knowingly enters into a lower tier covered transaction with a person who is suspended, debarred, ineligible, or voluntarily excluded from participation in this transaction, in addition to other remedies available to the Federal Government, the department or agency may terminate this transaction for cause or default.

\*\*\*\*\*

## **2. Certification Regarding Debarment, Suspension, Ineligibility and Voluntary Exclusion – First Tier Participants:**

a. The prospective first tier participant certifies to the best of its knowledge and belief, that it and its principals:

(1) Are not presently debarred, suspended, proposed for debarment, declared ineligible, or voluntarily excluded from participating in covered transactions by any Federal department or agency;

(2) Have not within a three-year period preceding this proposal been convicted of or had a civil judgment rendered against them for commission of fraud or a criminal offense in connection with obtaining, attempting to obtain, or performing a public (Federal, State or local) transaction or contract under a public transaction; violation of Federal or State antitrust statutes or commission of embezzlement, theft, forgery, bribery, falsification or destruction of records, making false statements, or receiving stolen property;

(3) Are not presently indicted for or otherwise criminally or civilly charged by a governmental entity (Federal, State or local) with commission of any of the offenses enumerated in paragraph (a)(2) of this certification; and

(4) Have not within a three-year period preceding this application/proposal had one or more public transactions (Federal, State or local) terminated for cause or default.

b. Where the prospective participant is unable to certify to any of the statements in this certification, such prospective participant shall attach an explanation to this proposal.

### **2. Instructions for Certification - Lower Tier Participants:**

(Applicable to all subcontracts, purchase orders and other lower tier transactions requiring prior FHWA approval or estimated to cost \$25,000 or more - 2 CFR Parts 180 and 1200)

a. By signing and submitting this proposal, the prospective lower tier is providing the certification set out below.

b. The certification in this clause is a material representation of fact upon which reliance was placed when this transaction was entered into. If it is later determined that the prospective lower tier participant knowingly rendered an erroneous certification, in addition to other remedies available to the Federal Government, the department, or agency with which

this transaction originated may pursue available remedies, including suspension and/or debarment.

c. The prospective lower tier participant shall provide immediate written notice to the person to which this proposal is submitted if at any time the prospective lower tier participant learns that its certification was erroneous by reason of changed circumstances.

d. The terms "covered transaction," "debarred," "suspended," "ineligible," "participant," "person," "principal," and "voluntarily excluded," as used in this clause, are defined in 2 CFR Parts 180 and 1200. You may contact the person to which this proposal is submitted for assistance in obtaining a copy of those regulations. "First Tier Covered Transactions" refers to any covered transaction between a grantee or subgrantee of Federal funds and a participant (such as the prime or general contract). "Lower Tier Covered Transactions" refers to any covered transaction under a First Tier Covered Transaction (such as subcontracts). "First Tier Participant" refers to the participant who has entered into a covered transaction with a grantee or subgrantee of Federal funds (such as the prime or general contractor). "Lower Tier Participant" refers any participant who has entered into a covered transaction with a First Tier Participant or other Lower Tier Participants (such as subcontractors and suppliers).

e. The prospective lower tier participant agrees by submitting this proposal that, should the proposed covered transaction be entered into, it shall not knowingly enter into any lower tier covered transaction with a person who is debarred, suspended, declared ineligible, or voluntarily excluded from participation in this covered transaction, unless authorized by the department or agency with which this transaction originated.

f. The prospective lower tier participant further agrees by submitting this proposal that it will include this clause titled "Certification Regarding Debarment, Suspension, Ineligibility and Voluntary Exclusion-Lower Tier Covered Transaction," without modification, in all lower tier covered transactions and in all solicitations for lower tier covered transactions exceeding the \$25,000 threshold.

g. A participant in a covered transaction may rely upon a certification of a prospective participant in a lower tier covered transaction that is not debarred, suspended, ineligible, or voluntarily excluded from the covered transaction, unless it knows that the certification is erroneous. A participant is responsible for ensuring that its principals are not suspended, debarred, or otherwise ineligible to participate in covered transactions. To verify the eligibility of its principals, as well as the eligibility of any lower tier prospective participants, each participant may, but is not required to, check the Excluded Parties List System website (<https://www.epls.gov/>), which is compiled by the General Services Administration.

h. Nothing contained in the foregoing shall be construed to require establishment of a system of records in order to render in good faith the certification required by this clause. The knowledge and information of participant is not required to exceed that which is normally possessed by a prudent person in the ordinary course of business dealings.

i. Except for transactions authorized under paragraph e of these instructions, if a participant in a covered transaction knowingly enters into a lower tier covered transaction with a person who is suspended, debarred, ineligible, or voluntarily excluded from participation in this transaction, in addition to other remedies available to the Federal Government, the

department or agency with which this transaction originated may pursue available remedies, including suspension and/or debarment.

\*\*\*\*\*

**Certification Regarding Debarment, Suspension, Ineligibility and Voluntary Exclusion--Lower Tier Participants:**

1. The prospective lower tier participant certifies, by submission of this proposal, that neither it nor its principals is presently debarred, suspended, proposed for debarment, declared ineligible, or voluntarily excluded from participating in covered transactions by any Federal department or agency.

2. Where the prospective lower tier participant is unable to certify to any of the statements in this certification, such prospective participant shall attach an explanation to this proposal.

\*\*\*\*\*

**XI. CERTIFICATION REGARDING USE OF CONTRACT FUNDS FOR LOBBYING**

This provision is applicable to all Federal-aid construction contracts and to all related subcontracts which exceed \$100,000 (49 CFR 20).

1. The prospective participant certifies, by signing and submitting this bid or proposal, to the best of his or her knowledge and belief, that:

a. No Federal appropriated funds have been paid or will be paid, by or on behalf of the undersigned, to any person for influencing or attempting to influence an officer or employee of any Federal agency, a Member of Congress, an officer or employee of Congress, or an employee of a Member of Congress in connection with the awarding of any Federal contract, the making of any Federal grant, the making of any Federal loan, the entering into of any cooperative agreement, and the extension, continuation, renewal, amendment, or modification of any Federal contract, grant, loan, or cooperative agreement.

b. If any funds other than Federal appropriated funds have been paid or will be paid to any person for influencing or attempting to influence an officer or employee of any Federal agency, a Member of Congress, an officer or employee of Congress, or an employee of a Member of Congress in connection with this Federal contract, grant, loan, or cooperative agreement, the undersigned shall complete and submit Standard Form-LLL, "Disclosure Form to Report Lobbying," in accordance with its instructions.

2. This certification is a material representation of fact upon which reliance was placed when this transaction was made or entered into. Submission of this certification is a prerequisite for making or entering into this transaction imposed by 31 U.S.C. 1352. Any person who fails to file the required certification shall be subject to a civil penalty of not less than \$10,000 and not more than \$100,000 for each such failure.

3. The prospective participant also agrees by submitting its bid or proposal that the participant shall require that the language of this certification be included in all lower tier subcontracts, which exceed \$100,000 and that all such recipients shall certify and disclose accordingly.



**ATTACHMENT A - EMPLOYMENT AND MATERIALS  
PREFERENCE FOR APPALACHIAN DEVELOPMENT  
HIGHWAY SYSTEM OR APPALACHIAN LOCAL ACCESS  
ROAD CONTRACTS**

This provision is applicable to all Federal-aid projects funded under the Appalachian Regional Development Act of 1965.

1. During the performance of this contract, the contractor undertaking to do work which is, or reasonably may be, done as on-site work, shall give preference to qualified persons who regularly reside in the labor area as designated by the DOL wherein the contract work is situated, or the subregion, or the Appalachian counties of the State wherein the contract work is situated, except:

a. To the extent that qualified persons regularly residing in the area are not available.

b. For the reasonable needs of the contractor to employ supervisory or specially experienced personnel necessary to assure an efficient execution of the contract work.

c. For the obligation of the contractor to offer employment to present or former employees as the result of a lawful collective bargaining contract, provided that the number of nonresident persons employed under this subparagraph (1c) shall not exceed 20 percent of the total number of employees employed by the contractor on the contract work, except as provided in subparagraph (4) below.

2. The contractor shall place a job order with the State Employment Service indicating (a) the classifications of the laborers, mechanics and other employees required to perform the contract work, (b) the number of employees required in each classification, (c) the date on which the participant estimates such employees will be required, and (d) any other pertinent information required by the State Employment Service to complete the job order form. The job order may be placed with the State Employment Service in writing or by telephone. If during the course of the contract work, the information submitted by the contractor in the original job order is substantially modified, the participant shall promptly notify the State Employment Service.

3. The contractor shall give full consideration to all qualified job applicants referred to him by the State Employment Service. The contractor is not required to grant employment to any job applicants who, in his opinion, are not qualified to perform the classification of work required.

4. If, within one week following the placing of a job order by the contractor with the State Employment Service, the State Employment Service is unable to refer any qualified job applicants to the contractor, or less than the number requested, the State Employment Service will forward a certificate to the contractor indicating the unavailability of applicants. Such certificate shall be made a part of the contractor's permanent project records. Upon receipt of this certificate, the contractor may employ persons who do not normally reside in the labor area to fill positions covered by the certificate, notwithstanding the provisions of subparagraph (1c) above.

5. The provisions of 23 CFR 633.207(e) allow the contracting agency to provide a contractual preference for the use of mineral resource materials native to the Appalachian region.

6. The contractor shall include the provisions of Sections 1 through 4 of this Attachment A in every subcontract for work which is, or reasonably may be, done as on-site work.

**Title 46 - Shipping**

Volume: 8

Date: 2014-10-01

Original Date: 2014-10-01

Title: Section 381.7 — Federal Grant, Guaranty, Loan and Advance of Funds Agreements.

Context: Title 46- Shipping. CHAPTER II- MARITIME ADMINISTRATION, DEPARTMENT OF TRANSPORTATION. SUBCHAPTER J - MISCELLANEOUS. PART 381 -CARGO PREFERENCE-U.S.- FLAG VESSELS.

**§ 381.7 Federal Grant, Guaranty, Loan and Advance of Funds Agreements.**

In order to insure a fair and reasonable participation by privately owned United States-flag commercial vessels in transporting cargoes which are subject to the Cargo Preference Act of 1954 and which are generated by U.S. Government Grant, Guaranty, loan and/or Advance of Funds Programs, the head of each affected department or agency shall require appropriate clauses to be inserted in those Grant, Guaranty, Loan and/or Advance of Funds Agreements and all third party contracts executed between the borrower/grantee and other parties, where the possibility exists for ocean transportation of items procured, contracted for or otherwise obtained by or on behalf of the grantee, borrower, or any of their contractors or subcontractors. The clauses required by this part shall provide that at least 50 percent of the freight revenue and tonnage of cargo generated by the U.S. Government Grant, Guaranty, Loan or Advance of Funds be transported on privately owned United States-flag commercial vessels. These clauses shall also require that all parties provide to the Maritime Administration the necessary shipment information as set forth in § 381.3. A copy of the appropriate clauses required by this part shall be submitted by each affected agency or department to the Secretary, Maritime Administration, for approval no later than 30 days after the effective date of this part. The following are suggested acceptable clauses with respect to the use of United States-flag vessels to be incorporated in the Grant, Guaranty, Loan and/or Advance of Funds Agreements as well as contracts and subcontracts resulting therefrom:

*(a) Agreement Clauses.* "Use of United States-flag vessels:

"(1) Pursuant to Pub. L. 664 (43 U.S.C. 1241(b)) at least 50 percent of any equipment, materials or commodities procured, contracted for or otherwise obtained with funds granted, guaranteed, loaned, or advanced by the U.S. Government under this agreement, and which may be transported by ocean vessel, shall be transported on privately owned United States-flag commercial vessels, if available.

"(2) Within 20 days following the date of loading for shipments originating within the United States or within 30 working days following the date of loading for shipments originating outside the United States, a legible copy of a rated, 'on-board' commercial ocean bill-of-lading in English for each shipment of cargo described in paragraph (a)(1) of this section shall be furnished to both the Contracting Officer (through the prime contractor in the case of subcontractor bills-of-lading) and to the Division of National Cargo, Office of Market Development, Maritime Administration, Washington, DC 20590."

*(b) Contractor and Subcontractor Clauses.* "Use of United States-flag vessels: The contractor agrees-

"(1) To utilize privately owned United States-flag commercial vessels to ship at least 50 percent of the gross tonnage (computed separately for dry bulk carriers, dry cargo liners, and tankers) involved, whenever shipping any equipment, material, or commodities pursuant to this contract, to the extent such vessels are available at fair and reasonable rates for United States-flag commercial vessels.

"(2) To furnish within 20 days following the date of loading for shipments originating within the United States or within 30 working days following the date of loading for shipments originating outside the United States, a legible copy of a rated, 'on-board' commercial ocean bill-of-lading in English for each shipment of cargo described in paragraph (b) (1) of this section to both the Contracting Officer (through the prime contractor in the case of subcontractor bills-of-lading) and to the Division of National Cargo, Office of Market Development, Maritime Administration, Washington, DC 20590.

"(3) To insert the substance of the provisions of this clause in all subcontracts issued pursuant to this contract."

(Reorganization Plans No. 21 of 1950 (64 Stat. 1273) and No. 7 of 1961 (75 Stat 840) as amended by Pub. L. 91-469 (84 Stat. 1036) and Department of Commerce Organization Order 10-8 (38 FR 19707, July 23, 1973)) [42 FR 57126, Nov. 1, 1977]



