

# **City of Flint, Michigan**

*Third Floor, City Hall  
1101 S. Saginaw Street  
Flint, Michigan 48502  
[www.cityofflint.com](http://www.cityofflint.com)*



## **Meeting Agenda - Final**

**Monday, June 14, 2021**

**5:30 PM**

**ELECTRONIC PUBLIC MEETING**

### **CITY COUNCIL**

*Kate Fields, President, Ward 4*

*Maurice D. Davis, Vice President, Ward 2*

*Eric Mays, Ward 1*

*Jerri Winfrey-Carter, Ward 5*

*Monica Galloway, Ward 7*

*Santino J. Guerra, Ward 3*

*Herbert J. Winfrey, Ward 6*

*Allan Griggs, Ward 8*

*Eva L. Worthing, Ward 9*

*Inez M. Brown, City Clerk*

*Davina Donahue, Deputy Clerk*

**SPECIAL PUBLIC NOTICE -- ELECTRONIC PUBLIC MEETING****PUBLIC NOTICE  
FLINT CITY COUNCIL ELECTRONIC PUBLIC MEETING**

On Friday, October 5, 2020, the Michigan Supreme Court (MSC) issued an order declaring that the Emergency Powers of Governor (EPG) Act as an unconstitutional delegation of legislative authority, which was the primary authority relied on by Governor Whitmer for her COVID-19 related executive orders. Subsequently, Governor Whitmer requested that the MSC clarify that their order does not go into effect until October 30, 2020. On Monday October 12, 2020, the Michigan Supreme Court rejected Governor Whitmer's request to delay the effect of its decision to strike down the EPG. On, Tuesday, October 13, 2020, Senate Bill 1108 passed, amending the Open Meetings Act to allow municipalities to hold electronic meetings. On Friday, October 16, 2020, Governor Whitmer signed into law Senate Bill 1108 amending the Open Meetings Act. Subsequently, on December 22, 2020 Public Act 267 of 1976 was amended through Senate Bill 1246 extending the electronic meetings with no reason through March 31, 2021. The act also allows that after March 31, 2021, electronic meetings may be held if a local state of emergency was declared. On March 23, 2020, the Flint City Council extended Mayor Neeley's declaration of emergency indefinitely due to the COVID-19 pandemic. Therefore, the following meeting will be held electronically:

**Flint City Council Meeting,  
Monday, June 14, 2021, at 5:30 p.m.**

1. In order to speak during the **PUBLIC HEARING PERIOD** of the meeting by telephone, participants will also call (617) 944-8177:
  - a. All callers will be queued and muted until the Public Hearing portion of the agenda;
  - b. Public speakers will be unmuted in order and asked if they wish to address the City Council on ***THE SUBJECT OF THE PUBLIC HEARING SPECIFICALLY***;
  - c. Public speakers should state and spell their name for the record and will be allowed ten (10) minutes to speak during the public hearing;
  - d. The speaker will be returned to mute after the 10 minutes have expired.
2. In order to speak during the **PUBLIC SPEAKING PERIOD** of the meeting by telephone, participants will also call (617) 944-8177:
  - a. All callers will be queued and muted until the Public Speaking portion of the agenda;
  - b. Public speakers will be unmuted in order and asked if they wish to address the City Council ***ON ANY SUBJECT***;
  - c. Public speakers should state and spell their name for the record and will be allowed three (3) minutes for public speaking;
  - d. The speaker will be returned to mute after the 3 minutes have expired;
  - e. After the telephonic public speakers are completed, emailed public comments will be read by the City Clerk. All emailed public comments will be timed for 3 minutes;
  - f. Per Rules Governing Meetings of the Council (Rule 7.1 VII), there will only be one speaking opportunity per speaker.  
Consequently, public participants who call in and speak during the public speaking period of the meeting WILL NOT have written comments as submitted read by the City Clerk.
3. The public may send public comments by email to [CouncilPublicComment@cityofflint.com](mailto:CouncilPublicComment@cityofflint.com) no later than 10 minutes prior to the meeting start time of 5:30 p.m.
4. Persons with disabilities may participate in the meeting by the above-mentioned means or by emailing a request for an accommodation to [CouncilPublicComment@cityofflint.com](mailto:CouncilPublicComment@cityofflint.com), with the subject line ***Request for Accommodation***, or by contacting the City Clerk at (810) 766-7418 to request accommodation - including but not limited to interpreters.  
If there are any questions concerning this notice, please direct them to City Council office at (810) 766-7418.

## CALL TO ORDER

## ROLL CALL

## MEMBER REMOTE ANNOUNCEMENT

*Pursuant to the newly revised Open Meetings Act, each Council member shall state that they are attending the meeting remotely and shall state where he or she is physically located (county or city and state).*

## MEMBER CONTACT INFORMATION

*Eric Mays - (810) 922-4860; Maurice Davis - mdavis@cityofflint.com; Santino Guerra - sguerra@cityofflint.com; Kate Fields - kfields@cityofflint.com; Jerri Winfrey-Carter - jwinfrey-carter@cityofflint.com; Herbert Winfrey - (810) 691-7463; Monica Galloway - mgalloway@cityofflint.com; Allan Griggs - agriggs@cityofflint.com; Eva Worthing - eworthing@cityofflint.com*

## PROCEDURES ON CONDUCTING ELECTRONIC MEETINGS

*All boards and commissions must adhere to all laws established under the Michigan Compiled Laws and in accordance with the revisions to the Open Meetings Act adopted in Senate Bill 1246, as passed on December 17, 2020, and signed into law on December 22, 2020, and subsequent amendments that may be adopted.*

## READING OF DISORDERLY PERSONS CITY CODE SUBSECTION

*Any person that persists in disrupting this meeting will be in violation of Flint City Code Section 31-10, Disorderly Conduct, Assault and Battery, and Disorderly Persons, and will be subject to arrest for a misdemeanor. Any person who prevents the peaceful and orderly conduct of any meeting will be given one warning. If they persist in disrupting the meeting, that individual will be subject to arrest. Violators shall be removed from meetings.*

## PLEDGE OF ALLEGIANCE

## PRAYER OR BLESSING

## REQUEST FOR CHANGES AND/OR ADDITIONS TO AGENDA

*Council shall vote to adopt any amended agenda.*

## PRESENTATION OF MINUTES

210281 Summary Minutes/Flint City Council/April 12, 2021

Summary Minutes of the Flint City Council ELECTRONIC PUBLIC MEETING held Monday, April 12, 2021, at 6:34 p.m.

210282 Summary Minutes/Special Flint City Council/April 14, 2021

Summary Minutes of the Special Flint City Council ELECTRONIC PUBLIC MEETING held Wednesday, April 14, 2021, at 6:02 p.m.

210283 Summary Minutes/Flint City Council/April 26, 2021

Summary Minutes of the Flint City Council ELECTRONIC PUBLIC MEETING held Monday, April 26, 2021, at 6:44 p.m.

## SPECIAL ORDERS

210288 Special Order/Certificates of Recognition/City-Wide Clean-Up

A Special Order requested by City Council members to present a Certificate of Recognition to Andy Everman, for his compassionate volunteer assistance to many residents in the City of Flint, and to the following individuals and groups for helping with a City-Wide Clean-Up Day on May 15, 2021:

Ward 1

Jeanette Edwards

Bonnie Grass

Brownell Holmes Neighborhood Association

Ward 2

Historic Civic Park Business District

Ward 4

Eastside Franklin Park Neighborhood Association

Edna Sabucco

\*Neighborhood Engagement Hub

Flint Neighborhoods United

Genesee County Land Bank

\*Michael Freeman

Asbury United Methodist Church

Rev. Tommy McDoniel

\*Latinx

\*Asa Zuccaro

Andy Everman

Ward 5

Barbara Smith

University Park Homeowners Association

\*Asa Zuccaro

\*Latinx Technology & Community Center

Wendy Johnson

Joseph Schipani

Dereck Dohrman

\*Michael Freeman

Ward 6

Ballenger Highway Neighborhood Association

Ballenger Community Association  
\*Glendale Hills Neighborhood Association  
New Community Association  
Mott Park Neighborhood Association

Ward 7  
Evergreen Valley Block Watchers  
Johnetta Ricks  
Goldie Pollard  
Judge Herman Marable  
Heather Burnash  
McFarland House  
Erica Thrash-Sall  
\*Neighborhood Engagement Hub  
Republic Recycle

Ward 8  
West Flint Community Watch  
West Flint Crime Watch  
\*Glendale Hills Neighborhood Association  
Neithercut Elementary  
Southside Business and Residents Group  
Woodcroft Avenue Neighborhood Watch  
Knob Hill Neighborhood Group

Ward 9  
Shareka Howard

\*worked in multiple wards

- 210172** Special Order/Discussion/Finance Committee Vice Chair
- A Special Order as requested by Councilperson Worthing to discuss the Finance Committee Vice Chair.
- 210171** Special Order/Special Meeting/\$99 Million/COVID-19 Relief Funds
- A Special Order as requested by Councilperson Mays to discuss having a special meeting to talk about the \$99 million in COVID-19 relief funds.
- 210167** Special Order/Special Orders
- A Special Order as requested by Council President Fields to discuss Special Orders.
- 210124** Special Order/Bone Scans & Lead Measurement/Dr. Lawrence Reynolds
- A Special Order as requested by Council President Fields to allow Dr. Lawrence Reynolds to present his findings on bone scanning equipment and their use in measuring lead exposure.

**210070** Special Order/Hatch Act

A Special Order as requested by Council President Fields to discuss the Hatch Act of 1939, which prohibits some forms of political activity.

**PUBLIC HEARINGS****210233.6** Public Hearing/Brownfield Redevelopment Plan/James P. Cole Project (1809 James P. Cole)

A Public Hearing on the proposed Brownfield Redevelopment Plan for 1809 James P. Cole (James P. Cole Project.) [NOTE: Once approved, the Brownfield plan will allow the reimbursement of eligible project expenses from the additional tax revenue realized as a result of the redevelopment. The reimbursement can occur over the life of the plan, which is normally 30 years. The eligible reimbursable expenses are estimated at around \$2,541,508.00.]

**PUBLIC SPEAKING**

*Per the amended Rules Governing Meetings of the Council (as adopted by the City Council on Monday, June 12, 2017), three (3) minutes per speaker. Only one speaking opportunity per speaker.*

**COUNCIL RESPONSE**

*Per the amended Rules Governing Meetings of the Council (as adopted by the City Council on Monday, June 12, 2017), Councilpersons may respond to any public speaker, but only one response and only when all public speakers have been heard. Individual council response is limited to two minutes.*

**PETITIONS AND UNOFFICIAL COMMUNICATIONS****210285** 2021 Tax Rate Request/Michigan Department of Treasury/City of Flint (DDA)

Form L-4029 dated May 11, 2021, re: Millage Request Report to the County Board of Commissioners for a City of Flint - Downtown Development Authority (DDA) 2021 property tax levy.

**210286** 2021 Tax Rate Request/Michigan Department of Treasury/City of Flint

Form L-4029 dated May 11, 2021, re: Millage Request Report to the County Board of Commissioners for a City of Flint - Downtown Development Authority 2021 property tax levy.

**210287** Financial Report/Karegnondi Water Authority (KWA)

Communication received May 26, 2021, re: The Karegnondi Water Authority (KWA) April 2021 Financial Report.

**COMMUNICATIONS (from Mayor and Other City Officials)**

**210284** Traffic Engineering/Closure Permits

Sidewalk, Lane and Street Closure permits (10) dated May and June, 2021, for requested activities/events, with noted responsibility for the placement of the required traffic control devices, and/or personnel, for the protection of traffic and event participants.

**ADDITIONAL COMMUNICATIONS****APPOINTMENTS****210273** Appointment/Ethics and Accountability Board/Edna N. Sabucco

Resolution resolving that the Flint City Council approves the appointment of Edna N. Sabucco (1426 Maplewood Avenue, Flint, MI 48506) to the Ethics and Accountability Board for a six-year term commencing immediately and expiring June 26, 2026, as recommended by 4th Ward Councilperson Kate Fields. [NOTE: By way of background, Mr. D'Aigle resigned in December 2020 from a six-year term he was appointed to on June 25, 2020.]

**210274** Reappointment/Hurley Board of Hospital Managers/Christopher Flores

Resolution approving the reappointment of Christopher Flores (1502 Brookwood Drive, Flint, MI, 48503) to the Hurley Board of Hospital Managers for an additional five-year term, commencing immediately, and expiring April 30, 2026, as requested by Mayor Sheldon Neeley. [NOTE: By way of background, Mr. Flores' term on the Hurley Board of Hospital Managers expired April 30, 2020, although he continued to serve.]

**APPOINTMENTS (May Be Referred from Special Affairs)****RESOLUTIONS****210233.1** Approval/City of Flint Brownfield Redevelopment Project Authority/Brownfield Plan for the James P. Cole Project (1809 James P. Cole Boulevard)

Resolution resolving that the [Brownfield Plan for the James P. Cole Project (1809 James P. Cole Boulevard)] as submitted is hereby approved and adopted, and a copy of the plan and all amendments thereto shall be maintained on file in the City Clerk's office. [NOTE: Once approved, the Brownfield plan will allow the reimbursement of eligible project expenses from the additional tax revenue realized as a result of the redevelopment. The reimbursement can occur over the life of the plan, which is normally 30 years. The eligible reimbursable expenses are estimated at around \$2,541,508.00.]

**210252** Change Order #3/Contract/Boyd's Lawn & Landscaping/Mowing Abatement/Parks, Trails, Cemeteries, Centers & Triangles

Resolution resolving that the appropriate city officials, upon City Council's approval, are authorized to do all things necessary to enter into [change order #3] to the contract with Boyd's Lawn & Landscaping for to provide mowing services for parks, trails, cemeteries, centers and triangle for FY2022, pending adoption of the budget, in an amount NOT-TO-EXCEED \$154,500.00, as requested by Street Maintenance [Local Street Fund Acct. No. 203-449.201-801.000.] [NOTE: No aggregate total is listed.]

**210253** Multi-Year/Lease to Own Agreement/AIS Construction Equipment/Vogele Paver/Hamm Roller

Resolution resolving that the appropriate city officials, upon City Council's approval, are authorized to do all things necessary to enter into the third year of the contract with AIS Construction Equipment to lease for the [four-year] lease to purchase of a Vogele Paver and a Hamm Roller, as requested by Street Maintenance, in an annual amount NOT-TO-EXCEED \$125,266.56 [Local Street Fund Acct. No. 202-449.201-977.000 = \$49060.30 and Acct. No. 202-449.201-977.000 = \$13,572.98, and Major Street Fund Acct. No. 203-449.201-977.000 = \$49,060.29 and Acct. No. 230-449.201-977.000 = \$13,572.97.] [NOTE: The original agreement was a purchase order, not a contract, and no aggregate total is listed.]

**210255** Change Order #1//Lasercom LLC/Printing, Sorting and Mailing/Property Taxes/Postage

Resolution resolving that the proper city officials, upon City Council's approval, are authorized to do all things necessary to enter into change order #1 with Lasercom LLC to provide additional postage for the mailing of city property tax bills, as requested by Customer Service, in an amount NOT-TO-EXCEED \$24,500.00, and a contract total amount of \$173,590.00, under the same terms and conditions [General Fund Acct. No. 101-253.200-902.000.]

**210256** Contract/RNA Facilities Management/Janitorial Services

Resolution resolving that the appropriate city officials are authorized to do all things necessary to enter into a contract with RNA Facilities Management to provide janitorial services, as requested by DPW, in an amount NOT-TO-EXCEED \$176,000.00, pending budget adoption [General Fund Acct. No. 101-753.200-801.000 = \$138,560.00; Major Street Fund Acct. No. 202-449.201-801.000 = \$18,720.00; Sewer Fund Acct. No. 590-540.100-801.000 = \$9,360.00; and Water Fund Acct. No. 591-540.100-801.000 = \$9,360.00.]

**210257** Change Order #1/McNaughton-McKay Electric Co./Electrical Poles

Resolution resolving that the appropriate city officials, upon City Council's approval, are authorized to do all things necessary to enter into change order #1 to the contract with McNaughton-McKay Electric Co. to provide electrical poles, as requested by the Water Service Center, in an amount NOT-TO-EXCEED \$19,688.57, and a contract total amount of \$81,888.57, under the same terms and conditions [Sewer Fund Acct. No.



590-540.208-752.000, and Water Fund Acct. No. 591-540.202-752.000.]

**210258** Contract Extension/Ace-Saginaw Paving Co./Additional Asphalt Material

Resolution resolving that the proper City Officials are authorized to do all things necessary to extend the contract with Ace Saginaw Asphalt [Ace-Saginaw Paving Co.] to provide additional asphalt paving materials, in an amount NOT-TO-EXCEED \$11,000.00, and a contract total amount of \$793,188.00, as requested by Water and Sewer [Sewer Fund Acct. No. 590-540.208-782.000 = \$6,150.00, and Water Fund Acct. No. 591-540.202-782.000 = \$850.00 and Acct. No. 591-540.202-752.000 = \$4,000.00.]

**210259** Contract Extension/Aldridge Trucking/Additional Fill Sand

Resolution resolving that the appropriate city officials, upon City Council's approval, are authorized to do all things necessary to extend the contract with Aldridge Trucking to provide additional fill sand, in an amount NOT-TO-EXCEED \$10,000.00, and a contract total amount of \$108,000.00, under the same terms and conditions, as requested by the Water Service Center [Sewer Fund Acct. No. 290-540.202-752.000 = \$4,000.00 and Water Fund Acct. No. 591-540.208-752.000.]

**210260** Multi-Year/Contract/PVS Nolwood Chemical, Inc./Liquid Ferrous (Aqueous Ferrous Chlorine)

Resolution resolving that the appropriate city officials, upon City Council's approval, are authorized to do all things necessary to enter into the second year of the contract with PVS Nolwood Chemical, Inc. to provide liquid ferrous (aqueous ferrous chlorine) for FY2022, as requested by Water Pollution Control, in an annual amount not to exceed \$120,000.00, pending adoption of the budget [Sewer Fund Acct. No. 590-550.100-753.000.]

**210261** Multi-Year/Contract/Polydyne Inc./Liquid Cationic Polymer (Emulsion)

Resolution resolving that the appropriate city officials, upon City Council's approval, are authorized to do all things necessary to enter into the second year of the contract with Polydyne Inc. to provide liquid cationic polymer (emulsion) for FY2022, as requested by Water Pollution Control, in an annual amount NOT-TO-EXCEED \$98,000.00 [Sewer Fund Acct. No. 590-550.100-753.000.]

**210262** Contract/EJ USA, Inc./Fire Hydrants, Catch Basin Grates & Manhole Covers

Resolution resolving that the appropriate city officials, upon City Council's approval, are authorized to do all things necessary to enter into a contract with EJ USA, Inc. to provide fire hydrants, catch basin grates and manhole covers, as requested by the Water Service Center, in an amount NOT-TO-EXCEED \$120,000.00, pending adoption of the budget [Water Fund Acct. No. 591-540.202-752.000 = \$95,000.00, and Sewer Acct. No. 590-540.208-752.000 = \$25,000.00.]

- 210263**            Contract/Republic Services/Disposal/Sewage Sludge Cake Disposal
- Resolution resolving that the appropriate city officials, upon City Council's approval, are authorized to do all things necessary to enter into a contract with Republic Services to provide sewage sludge cake disposal services, as requested by Water Pollution Control, in an amount NOT-TO-EXCEED \$247,000.00, pending adoption of the budget [Sewer Fund Acct. No. 590-550.100-801.500.]
- 210264**            Three-Year Contract/DHT Transportation/Sewage Sludge Transport Services
- Resolution resolving that the proper city officials, upon City Council's approval, are authorized to do all things necessary to enter into a [three-year contract] with DHT Transportation to provide sludge disposal transportation services, as requested by Water Pollution Control, in an amount NOT-TO-EXCEED \$250,000.00 [for each of the next three years, pending adoption of each year's respective budget, for a total amount of \$750,000.00] [Sewer Fund Acct. No. 590-550.100-801.500.]
- 210265**            Contract/Duperon Corp./East Pump Station Washer Compactor
- Resolution resolving that the appropriate city officials, upon City Council's approval, are authorized to do all things necessary to enter into a contract with Duperon Corp. to provide the East Pump Station washer compactor, in an amount NOT-TO-EXCEED \$81,365.00, pending budget adoption, as requested by Water Pollution Control [Sewer Fund Acct. No. 590-550.300-977.000.]
- 210266**            Three-Year Contract/Fishbeck, Thompson, Carr & Huber, Inc./Comprehensive Regulatory Compliance Assistance
- Resolution resolving that the appropriate city officials, upon City Council's approval, are authorized to do all things necessary to enter into the second year of a (three-year) contract with Fishbeck, Thompson, Carr & Huber, Inc. to provide comprehensive regulatory compliance assistance, as requested by Water Pollution Control, in an amount NOT-TO-EXCEED \$100,000.00 per year [for a total amount of \$300,000.00], pending adoption of the budget [Sewer Fund Acct. No. 590-550.100-801.000.]
- 210267**            Change Order #1/Contract/Spalding DeDecker/Preliminary Engineering Services/Miller Road Rehabilitation
- Resolution resolving that the proper city officials, upon City Council's approval, are hereby authorized to enter into change order #1 to the contract with Spalding DeDecker to facilitate a design change during the Preliminary Engineering Services to rehabilitate Miller Road, in an amount NOT-TO-EXCEED \$25,000.00, and a revised aggregate amount of \$234,508.09, as requested by DPW [Water Capital Projects (WIIN) Fund Acct. No. 496-555.000-801.066.]

- 210268** Setting a Public Hearing/Rezoning Request/448 South Saginaw Street/From D-4 Metropolitan Business District to D-5 Metropolitan Commercial Services District

Resolution resolving that authorized officials will do all things necessary to schedule and hold a Public Hearing on the \_\_\_\_\_ day of \_\_\_\_\_ 2021, [via electronic meeting], for the purposes of allowing for public comment on the rezoning request for 448 South Saginaw Street. [NOTE: Shultz Acquisitions, LLC requests a rezoning from D-4 Metropolitan Business District to D-5 Metropolitan Commercial Services District at 448 South Saginaw Street to use the property for a Provisioning Center. Provisioning Centers, a Group E Special Regulated Use, require properties to be located in D-5, D-6, E, F or G zoning districts, which requires a public hearing.]

- 210269** Resolution of Support/Transportation Improvement Program (TIP) Projects/Genesee County Metropolitan Alliance/Resurfacing of Saginaw Street from Atherton Road to Oakley Street

Resolution resolving that this resolution is adopted to attest the city's support for moving the year for resurfacing of Saginaw Street from Atherton Road to Oakley Street from FY2023 to FY2022. The City of Flint's local match is in the amount of \$61,882.00, AND, resolving that this resolution attests to the city's commitment to providing local funding for its share of the resurfacing of Saginaw Street from Atherton Road to Oakley Street in FY2022 that was previously selected for inclusion in the FY2020-2023 Transportation Improvement Program (TIP). [NOTE: New funding for the program decreased the city's contribution from \$1,093,870.00 to \$61,882.00.]

- 210270** Charitable Gaming License/State of Michigan Lottery Charitable Gaming Division/Back to the Bricks, Inc.

Resolution resolving that Back to the Bricks, Inc. is recognized as a non-profit organization operating in the city of Flint for the purpose of obtaining a charitable gaming license, as issued by the State of Michigan Lottery Charitable Gaming Division, relative to conducting charity and fundraising events, as allowed by Act 382 of the Public Acts of 1972, as amended. [NOTE: Back to the Bricks, Inc. plans to conduct a 50/50 raffle on August 17 through August 21 in downtown Flint and the US-23 Drive-In.]

## **RESOLUTIONS (May Be Referred from Special Affairs)**

- 210280** Grant Acceptance/Budget Amendment/Transfer of Funds/U.S. Department of Treasury/American Rescue Plan Act/Coronavirus Local Fiscal Recovery Fund

Resolution resolving that the appropriate city officials, upon City Council's approval, are hereby authorized to do all things necessary to appropriate grant funding and abide by terms and conditions of the grant from the U.S. Department of Treasury for addressing the Public Health and Economic Impacts of the COVID-19 Public Health Emergency under Grant Code FUSDT-CSLFRF, in the amount of \$94,726,664.00, and to make available in subsequent fiscal years any remaining

funds that are still available from the grantor. [NOTE: As part of the American Rescue Plan Act, the City of Flint was awarded grant funding from the Coronavirus Local Fiscal Recovery Fund through the U.S. Department of Treasury. The city's allocation of the funds totals \$94,726,664.00. The city received the first of two payments on May 19, 2021, for \$47,363,332.00; the second payment is expected in May 2022.]

## **LIQUOR LICENSES**

### **INTRODUCTION AND FIRST READING OF ORDINANCES**

210158           Amendment/Ordinance/Chapter 18 (Taxation; Funds; Purchasing)/Article I (In General)/Section 18-4.1 (Service Charge in Lieu of Taxes for Housing Facilities for Certain Persons)

The provisions of Chapter 18, (Taxation; Funds; Purchasing); Article I, (In General); Section 18-4.1, (Service Charge in Lieu of Taxes for Housing Facilities for Certain Persons) shall be amended by adding subsection (GG). [NOTE: The PILOT is for Flushing Place Limited Dividend Housing Association, LP, a Limited Partnership. The annual service charge for the class of persons of low and moderate income shall be equal to four (4) percent of the annual shelter rents, exclusive of charges for gas, electricity, heat or other utilities furnished to the occupants.]

### **INTRODUCTION AND FIRST READING OF ORDINANCES (May Be Referred from Special Affairs)**

### **SECOND READING AND ADOPTION OF ORDINANCES**

### **FINAL COUNCIL COMMENTS**

### **ADJOURNMENT**

210281

## **City of Flint, Michigan**

*Third Floor, City Hall  
1101 S. Saginaw Street  
Flint, Michigan 48502  
www.cityofflint.com*



### **Meeting Minutes**

**Monday, April 12, 2021**

**6:34 PM**

\*

**ELECTRONIC PUBLIC MEETING**

### **CITY COUNCIL**

*Kate Fields, President, Ward 4  
Maurice D. Davis, Vice President, Ward 2*

*Eric Mays, Ward 1  
Jeri Winfrey-Carter, Ward 5  
Monica Galloway, Ward 7*

*Santino J. Guerra, Ward 3  
Herbert J. Winfrey, Ward 6  
Allan Griggs, Ward 8*

*Eva L. Worthing, Ward 9*

*Inez M. Brown, City Clerk*

*Davina Donahue, Deputy Clerk*

## CALL TO ORDER

*Council President Kate Fields called this meeting to order at 6:34 p.m.*

## ROLL CALL

**Present:** Councilperson: Councilperson Mays, Councilperson Davis, Councilperson Guerra, Councilperson Fields, Councilperson Winfrey-Carter, Winfrey, Councilperson Griggs and Councilperson Worthing

**Absent:** Councilperson: Councilperson Galloway

## REQUESTS FOR CHANGES OR ADDITIONS TO AGENDA

*Councilperson Fields made a motion to do Special Orders after Discussion Items. The motion passed 8-0. Councilperson Fields asked to add three discussion items (and do them first on the agenda). The vote was 8-0. Councilperson Worthing made a motion to include a Special Order to discuss the Finance Vice Chair after Presentation of Minutes. The motion passed 6-2 (No: Guerra, Winfrey-Carter). Councilperson Mays asked to have a Special Order to discuss having a special meeting to discuss the \$99.3 million the city has coming from the COVID-19 Relief Package. The vote was 8-0.*

## SPECIAL ORDERS

**210172** Special Order/Discussion/Finance Committee Vice Chair

A Special Order as requested by Councilperson Worthing to discuss the Finance Committee Vice Chair.

*Councilperson Worthing made a motion, supported by Councilperson Griggs, to remove Councilperson Galloway as Finance Vice Chairperson so President Fields can make her own choice for Vice Chair. Councilperson Mays made a substitute motion to table the discussion until the next Council meeting, when Councilperson Galloway will be in attendance. The motion passed 7-1 (No: Griggs).*

## PUBLIC HEARINGS

**210044.6** Ordinance 210044

A Public Hearing for Ordinance 210044, an ordinance to amend Chapter 50 (Zoning), Article I, (In General), of the Code of the City of Flint by repealing said Article and adopting Article I (Title, Purpose and Scope). [NOTE: This Chapter shall be known as the "Zoning Ordinance" of the City of Flint.]

**HEARING HELD**

**210045.6** Ordinance 210045

A Public Hearing for Ordinance 210045, an ordinance to amend Chapter 50 (Zoning), Article II, (A-1 Single-Family Low-Density District), of the Code of the City of Flint by repealing said Article and adopting Article II (Mapped Zone Districts).

**HEARING HELD****210046.6** Ordinance 210046

A Public Hearing for Ordinance 210046, an ordinance to amend Chapter 50 (Zoning), Article III, (A-2 Single-Family Medium Density District), of the Code of the City of Flint by repealing said Article and adopting Article III (Residential Zone Districts).

**HEARING HELD****210047.6** Ordinance 210047

A Public Hearing for Ordinance 210047, an ordinance to amend Chapter 50 (Zoning), Article IV, (B Two-Family District), of the Code of the City of Flint by repealing said Article and adopting Article IV (Commercial Zone Districts).

**HEARING HELD****210048.6** Ordinance 210048

A Public Hearing for Ordinance 210048, an ordinance to amend Chapter 50 (Zoning), Article V, (C-1 Multifamily Walk-Up Apartment District), of the Code of the City of Flint by repealing said Article and adopting Article V (Employment Zone Districts).

**HEARING HELD****210049.6** Ordinance 210049

A Public Hearing for Ordinance 210049, an ordinance to amend Chapter 50 (Zoning), Article VI, (C-2 Multifamily High-Density Apartment District), of the Code of the City of Flint by repealing said Article and adopting Article VI (Institutional/Innovation Zoned Districts).

**HEARING HELD****210063.6** Public Hearing/Street Vacation/Decker Street Between Robert T. Longway Boulevard and Kearsley Street

A public hearing to consider the vacation of Decker Street between Robert T. Longway Boulevard and Kearsley Street. [NOTE: The Ruth Mott Foundation's Applewood Master Plan calls for the construction of a welcome center... which will offer year-round education, conference and exhibit spaces open to the community and broader access to the archives and collection materials that are part of the foundation.]

**HEARING HELD****210064.6** Public Hearing/Street Vacation/Kearsley Street Between Walnut and Robert T. Longway Boulevard (1400 Kearsley Street)

A public hearing to consider the vacation of Kearsley Street between Walnut and Robert T. Longway Boulevard (1400 Kearsley Street). [NOTE: The Ruth Mott Foundation's Applewood Master Plan calls for the construction of a welcome center... which will offer year-round education, conference and exhibit spaces open to the community and broader access to the archives and collection materials that are part of the foundation.]

#### HEARING HELD

#### 210085.6 Public Hearing/Ordinance 210085

A Public Hearing for Ordinance No. 210085, an ordinance to amend the Flint City Code of Ordinances by amending Chapter 18 (Taxation; Funds; Purchasing), Article II (Assessments), by amending Section 18-7 (Special Assessment Relief Board Created; Membership), by amending Section 18-8 (Same -- Investigation of Requests for Relief; Report and Recommendation), by amending Section 18-9 (Award of Relief from Assessments), and by amending Section 18-10 (Payment of Special Assessment by City; Taking of Mortgage and Note to Assure Repayment to City). [NOTE: Ordinance to become effective 30 days after adoption.]

#### HEARING HELD

### MOTION TO RECESS

*Councilperson Worthing, with support from Councilperson Griggs, made a motion to recess the meeting until 6 p.m. Wednesday, April 14, 2021. The vote was 6-1 (No: Davis; Absent: Guerra, Galloway.)*

### RECONSIDERATION (of Appointments)

#### 210123 Mayoral Appointment/Department of Public Works (DPW) Director/Michael Brown

Resolution resolving that the Flint City Council approves the recommendation by Mayor Sheldon A. Neeley to appoint Michael Brown as the Director of the Department of Public Works (DPW). [NOTE: Mr. Brown will be paid an annual compensation rate of \$95,000.00 (45.673 per hour).]

#### POSTPONED

### APPOINTMENTS

### APPOINTMENTS (May be Referred from Special Affairs)

#### 210102 Mayoral Appointment/Chief Financial Officer/Shelbi Frayer

Resolution resolving that the Flint City Council approves the recommendation by Mayor Sheldon Neeley to appoint Shelbi Frayer as Chief Financial Officer [at an hourly compensation rate of \$71.153 per hour (\$148,100.00 annually).]



[General Fund Salary and Wages Acct. No. 101-191.100-703.000 = \$91,976.90 and LCSM-17-FRTA = \$56,032.10.]

**POSTPONED**

**210154** Appointment/Water System Advisory Council/Sheryl Thompson

Resolution resolving that Mayor Neeley hereby appoints Sheryl Thompson (4709 Crestbrook Lane, Flint, MI 48507) to serve on the Water System Advisory Council. [NOTE: Pursuant to the State of Michigan's administrative rules, water suppliers serving a population of 50,000 or more, shall create a Water System Advisory Council. The purpose of the Council is to improve transparency in the City of Flint community by developing materials and advising the water system on public awareness and education efforts.]

**POSTPONED**

**210155** Appointment/Water System Advisory Council/James Gaskin

Resolution resolving that Mayor Neeley hereby appoints James Gaskin (41225 Lori Lane, Fenton, MI 48430) to serve on the Water System Advisory Council. [NOTE: Pursuant to the State of Michigan's administrative rules, water suppliers serving a population of 50,000 or more, shall create a Water System Advisory Council. The purpose of the Council is to improve transparency in the City of Flint community by developing materials and advising the water system on public awareness and education efforts.]

**POSTPONED**

**210156** Appointment/Water System Advisory Council/Earnestine Yvonne Lewis

Resolution resolving that Mayor Neeley hereby appoints Earnestine Yvonne Lewis (2171 South Linden Road, Flint, MI 48532) to serve on the Water System Advisory Council. [NOTE: Pursuant to the State of Michigan's administrative rules, water suppliers serving a population of 50,000 or more, shall create a Water System Advisory Council. The purpose of the Council is to improve transparency in the City of Flint community by developing materials and advising the water system on public awareness and education efforts.]

**POSTPONED**

**210157** Appointment/Water System Advisory Council/Nancy Love

Resolution resolving that Mayor Neeley hereby appoints Nancy Love (1351 Beal Avenue, Ann Arbor, MI 48109) to serve on the Water System Advisory Council. [NOTE: Pursuant to the State of Michigan's administrative rules, water suppliers serving a population of 50,000 or more, shall create a Water System Advisory Council. The purpose of the Council is to improve transparency in the City of Flint community by developing materials and advising the water system on public awareness and education efforts.]

**POSTPONED**

210166 Appointment/Human Relations Commission/Sharon M. Bradley/6th Ward

Resolution resolving that the Flint City Council approves the appointment of Sharon M. Bradley (333 Ferndale Place, Flint, MI, 48503), to serve on the City of Flint Human Relations Commission for a one-year term, commencing October 27, 2020, and expiring October 28, 2021.

**POSTPONED**

## **RECONSIDERATION (of Resolutions)**

210081 CO#1/Contract/Rowe Professional Services Co./Project Management Services/FAST Start Program Phase VI

Resolution resolving that the proper city officials, upon City Council's approval, are hereby authorized to enter into change order #1 with Rowe Professional Services Co. for additional project management services for Phase VI of the FAST Start Program, as requested by DPW, in an amount NOT-TO-EXCEED \$500,000.00, for a total contract price NOT-TO-EXCEED \$2,638,735.00 [Water Infrastructure Improvements for the Nation (WIIN) Grant Acct. No. 496-540.006-801.051.]

**POSTPONED**

## **RESOLUTIONS**

210144 Licensing Renewal/Dell Marketing LP/Microsoft

Resolution resolving that the proper city officials, upon City Council's approval, are hereby authorized to issue a purchase order to Dell Marketing LP for Microsoft License renewal, as requested by Information Services, in an amount NOT-TO-EXCEED \$86,557.67 [Information Services Fund Acct. No. 636-228.100-814.600.] [NOTE: This is the third year of a three-year agreement.]

**POSTPONED**

210145 J&M Tree Service/Additional Tree Work/City Parks

Resolution resolving that the proper city officials, upon City Council's approval, are authorized to do all things necessary to increase to total contracted amount with J&M Tree Service for additional tree work needed in city parks, as requested by Parks & Recreation, in an amount NOT-TO-EXCEED \$10,000.00 [Parks & Recreation Fund Professional Services Acct. No. 208-752.102-801.000]. [NOTE: The additional work needed total \$10,000.00 and would be set up as a new purchase order for emergency tree removal and trimming in parks.]

**POSTPONED**

**210146** Contract/Platinum Mechanical, Inc./Sludge Storage Pipe Fabrication Project

Resolution resolving that the appropriate city officials, upon City Council's approval, are authorized to do all things necessary to issue a contract to Platinum Mechanical, Inc. for a Sludge Storage Pipe Fabrication project, as requested by DPW, in an amount NOT-TO-EXCEED \$131,477.00 [Sewer Fund Building Additions & Improvements Acct. No. 590-550.300-976-000.]

**POSTPONED**

**210147** Settlement/Stacy Swimp v Mary Buszek et al/Case No. 2:18-cv-11914

Resolution resolving that the City Administrator hereby authorizes settlement, in the matter of Stacy Swimp v Mary Buszek et al, Case No. 2:18-cv-11914, in the amount of \$79,500.00, in satisfaction of any and all claims arising out of said matter, with payment drawn from appropriated funds in the Litigation and Suits Line Item No. 677-266.200-956.300. [NOTE: An Executive Session was requested on this matter on March 8, 2021.]

**POSTPONED**

**210148** Payment/Settlement Agreement/Mackinac Center for Public Policy v City of Flint/Case No. 21-115412-CZ

Resolution resolving that the City Administrator is hereby authorized to pay the settlement offer in the matter of Mackinac Center for Public Policy v City of Flint, in the amount of \$175.00, in satisfaction of any and all claims arising out of said matter, with payment drawn from appropriated funds in the Litigation and Suits Line Item No. 677-266.200-956.300. [NOTE: An Executive Session was held on this matter on February 8, 2021.]

**POSTPONED**

**210163** Approval/Deficit Elimination Plan/Downtown Development Authority (DDA)/Self-Insurance Fund

Resolution resolving that the City Council approves the Deficit Elimination Plan as outlined. The City of Flint's Chief Financial Officer is authorized to do all things necessary to submit the Deficit Elimination Plan to the Michigan Department of Treasury for certification. [NOTE: The Downtown Development Authority has a deficit balance of \$138,003.00 as of June 30, 2020. Any costs not covered by the DDA will be covered by the city's General Fund. And the Self-Insurance Fund incurred numerous expenses related to insurance and legal costs, putting it in the red by \$922,563.00, as of June 30, 2020.]

**POSTPONED**

**210164** Easement Agreement/Genesee County Drain Commission (GCDC)/North Dort Highway Property at Frances Road

Resolution resolving that the Flint City Council approves the grant of a permanent

non-exclusive easement to the Genesee County Drain Commission to own, operate and maintain the GCDC FL-02 Meter Facility for valuable consideration in the amount of \$1.00 to be paid to the City of Flint. [NOTE: The City of Flint entered into a Master Agreement on December 1, 2017, to build a secondary water source. The City of Flint has agreed to grant an easement to the GCDC on the city-owned property on North Dort Highway at Frances Road for valuable consideration in the amount of \$1.00.]

**POSTPONED**

- 210165** Easement Agreement/Great Lakes Water Authority (GLWA)/North Dort Highway Property at Frances Road

Resolution resolving that the Flint City Council approves the grant of a permanent non-exclusive easement to the Great Lakes Water Authority (GLWA) to construct, operate, maintain, repair and/or replace the GLWA water main pipe for valuable consideration in the amount of \$1.00 to be paid to the City of Flint. [NOTE: The City of Flint entered into a Master Agreement on December 1, 2017, to build a secondary water source. The City of Flint has agreed to grant an easement to GLWA on the city-owned property on North Dort Highway at Frances Road for valuable consideration in the amount of \$1.00.]

**POSTPONED**

**RESOLUTIONS - MAY BE REFERRED FROM S.A.**

- 200493** Approval/Emergency Amended Rules Governing Meetings of the Flint City Council

Resolution resolving that the Flint City Council approves the attached amendments to the [Rules Governing Meetings of the Flint City Council], for 60 days, with immediate effect.

**POSTPONED**

- 210149** Name Change/12th Street Garage/Betty Wideman Building

Resolution resolving that the Flint City Council hereby authorizes the renaming of the 12th Street Garage, located at 702 West Twelfth Street, Flint, to The Betty Wideman Building. [NOTE: Betty Wideman began her career at the City of Flint in 1994, starting in the Police Department, and ending as Transportation Division Manager. Tragically, she passed away in November 2020.]

**POSTPONED**

- 210150** Approval/Street Vacation/Decker Street Between Robert T. Longway Boulevard and Kearsley Street

Resolution resolving that Decker Street Between Robert T. Longway Boulevard and Kearsley Street is hereby vacated and discontinued forever as a public street, alley

or public ground, and the same is hereby placed on the assessment rolls for the purpose of taxation; AND, resolving that the City Clerk shall, within 30 days of this action, record a certified copy of this resolution with the Register of Deeds for Genesee County and forward a certified copy of said resolution to the State Treasurer. [NOTE: The Ruth Mott Foundation's Applewood Master Plan calls for the construction of a welcome center... which will offer year-round education, conference and exhibit spaces open to the community and broader access to the archives and collection materials that are part of the foundation.]

**POSTPONED**

- 210151** Approval/Street Vacation/Kearsley Street Between Walnut Street and Robert T. Longway Boulevard (1400 Kearsley Street)

Resolution resolving that Kearsley Street between Walnut Street and Robert T. Longway Boulevard is hereby vacated and discontinued forever as a public street, alley or public ground, and the same is hereby placed on the assessment rolls for the purpose of taxation; AND, resolving that the City Clerk shall, within 30 days of this action, record a certified copy of this resolution with the Register of Deeds for Genesee County and forward a certified copy of said resolution to the State Treasurer. [NOTE: The Ruth Mott Foundation's Applewood Master Plan calls for the construction of a welcome center... which will offer year-round education, conference and exhibit spaces open to the community and broader access to the archives and collection materials that are part of the foundation.]

**POSTPONED**

- 210152** Setting a Public Hearing/Brownfield Redevelopment Plan/James P. Cole Project (1809 James P. Cole)

Resolution resolving that the Flint City Council will hold a public hearing at 5:30 p.m. in the City Council Chambers, or electronically in accordance with Gov. Whitmer's Executive Order 2020-75, on the \_\_\_\_\_ day of \_\_\_\_\_ 2021, AND, resolving that the governing body shall provide notice of the hearing to the taxing jurisdictions that levy taxes subject to capture under this Act, and shall fully inform the taxing jurisdictions about the fiscal and economic implications of the proposed Brownfield Plan.

**POSTPONED**

- 210153** Support/Application/Michigan Department of Transportation (MDOT)/Transportation Alternatives Program (TAP)/Development/Grand Traverse Greenway Trail

Resolution resolving that the appropriate City of Flint officials are authorized to do all things necessary to demonstrate its public support of the city's application to the Michigan Department of Transportation's Transportation Alternatives Program for the Grand Traverse Greenway project and commits to the requirements [of the program.] [NOTE: The city is planning to redevelop abandoned railroad property into a shared use non-motorized paved trail called the Grand Traverse Greenway.

Planning & Development has prepared a competitive application to the TAP program requesting \$1,804,825.00 from MDOT-TAP, which the city expects to be matched at \$860,000.00 (32 percent of total project costs) through public and private sources to be finalized before the grant award).

**POSTPONED**

**210159** Submission/2020-2021 Annual Action Plan of the Consolidated Plan

Resolution resolving that city officials approve the funding amounts and projects and authorize entering into contracts for the agencies noted for the City of Flint's FY2020-2021 Community Development Block Grant (CDBG) Program, in the amount of \$3,984,754.00, FY2020-2021 HOME Investment Partnership (HOME) Program, in the amount of \$876,146.00, and FY2020-2021 Emergency Solutions Grant (ESG) Program, in the amount of \$341,765.00, and include any program income which might become available as a result of receipt of these funds.

**POSTPONED**

## **INTRODUCTION AND FIRST READING OF ORDINANCES (May Be Referred from Special Affairs)**

**210158** Amendment/Ordinance/Chapter 18 (Taxation; Funds; Purchasing)/Article I (In General)/Section 18-4.1 (Service Charge in Lieu of Taxes for Housing Facilities for Certain Persons)

The provisions of Chapter 18, (Taxation; Funds; Purchasing); Article I, (In General); Section 18-4.1, (Service Charge in Lieu of Taxes for Housing Facilities for Certain Persons) shall be amended by adding subsection (GG). [NOTE: The PILOT is for Flushing Place Limited Dividend Housing Association, LP, a Limited Partnership. The annual service charge for the class of persons of low and moderate income shall be equal to four (4) percent of the annual shelter rents, exclusive of charges for gas, electricity, heat or other utilities furnished to the occupants.]

**POSTPONED**

## **SECOND READING AND ENACTMENT OF ORDINANCES**

**210044** Ordinance/Chapter 50 (Zoning)/Article I (In General)

An ordinance to amend Chapter 50 (Zoning), Article I, (In General), of the Code of the City of Flint by repealing said Article and adopting Article I (Title, Purpose and Scope). [NOTE: This Chapter shall be known as the "Zoning Ordinance" of the City of Flint.]

**POSTPONED**

**210045** Ordinance/Chapter 50 (Zoning)/Article II (A-1 Single-Family Low-Density District)

An ordinance to amend Chapter 50 (Zoning), Article II, (A-1 Single-Family Low-Density District), of the Code of the City of Flint by repealing said Article and adopting Article II (Mapped Zone Districts).

**POSTPONED**

**210046** Ordinance/Chapter 50 (Zoning)/Article III (A-2 Single-Family Medium Density District)

An ordinance to amend Chapter 50 (Zoning), Article III, (A-2 Single-Family Medium Density District), of the Code of the City of Flint by repealing said Article and adopting Article III (Residential Zone Districts).

**POSTPONED**

**210047** Ordinance/Chapter 50 (Zoning)/Article IV (B Two-Family District)

An ordinance to amend Chapter 50 (Zoning), Article IV, (B Two-Family District), of the Code of the City of Flint by repealing said Article and adopting Article IV (Commercial Zone Districts).

**POSTPONED**

**210048** Ordinance/Chapter 50 (Zoning)/Article V (C-1 Multifamily Walk-Up Apartment District)

An ordinance to amend Chapter 50 (Zoning), Article V, (C-1 Multifamily Walk-Up Apartment District), of the Code of the City of Flint by repealing said Article and adopting Article V (Employment Zone Districts).

**POSTPONED**

**210049** Ordinance/Chapter 50 (Zoning)/Article VI (C-2 Multifamily High-Density Apartment District)

An ordinance to amend Chapter 50 (Zoning), Article VI, (C-2 Multifamily High-Density Apartment District), of the Code of the City of Flint by repealing said Article and adopting Article VI (Institutional/Innovation Zoned Districts).

**POSTPONED**

**210085** Ordinance/Amendment/Chapter 18 (Taxation; Funds; Purchasing)/Article II (Assessments)/Amendment of Sections 18-7, 18-8, 18-9 and 18-10

An ordinance to amend the Flint City Code of Ordinances by amending Chapter 18 (Taxation; Funds; Purchasing), Article II (Assessments), by amending Section 18-7 (Special Assessment Relief Board Created; Membership), by amending Section 18-8 (Same -- Investigation of Requests for Relief; Report and Recommendation), by amending Section 18-9 (Award of Relief from Assessments), and by amending Section 18-10 (Payment of Special Assessment by City; Taking of Mortgage and

Note to Assure Repayment to City).

**POSTPONED**

## **SPECIAL ORDERS CONTINUED**

*All Special Orders were postponed to 4-14-21.*

**210070** Special Order/Hatch Act

A Special Order as requested by Council President Fields to discuss the Hatch Act of 1939, which prohibits some forms of political activity.

**210124** Special Order/Bone Scans & Lead Measurement/Dr. Lawrence Reynolds

A Special Order as requested by Council President Fields to allow Dr. Lawrence Reynolds to present his findings on bone scanning equipment and their use in measuring lead exposure.

**210167** Special Order/Special Orders

A Special Order as requested by Council President Fields to discuss Special Orders.

## **ADJOURNMENT**

*The meeting recessed at 11:41 p.m.*



210282

## **City of Flint, Michigan**

*Third Floor, City Hall  
1101 S. Saginaw Street  
Flint, Michigan 48502  
[www.cityofflint.com](http://www.cityofflint.com)*



### **Meeting Minutes - Draft**

**Wednesday, April 14, 2021**

**6:02 PM**

**\*Meeting recessed from April 12, 2021**

**ELECTRONIC PUBLIC MEETING**

### **CITY COUNCIL**

*Kate Fields, President, Ward 4  
Maurice D. Davis, Vice President, Ward 2*

*Eric Mays, Ward 1  
Jerri Winfrey-Carter, Ward 5  
Monica Galloway, Ward 7*

*Santino J. Guerra, Ward 3  
Herbert J. Winfrey, Ward 6  
Allan Griggs, Ward 8*

*Eva L. Worthing, Ward 9*

*Inez M. Brown, City Clerk*

*Davina Donahue, Deputy Clerk*

## CALL TO ORDER

*Council President Kate Fields called the meeting to order at 6:02 p.m.*

## ROLL CALL

**Present:** Councilperson: Councilperson Mays, Councilperson Davis, Councilperson Guerra, Councilperson Fields, Councilperson Winfrey-Carter, Winfrey, Councilperson Griggs and Councilperson Worthing

**Absent:** Councilperson: Councilperson Galloway

## RECONSIDERATION (of Appointments)

210123            Mayoral Appointment/Department of Public Works (DPW) Director/Michael Brown

Resolution resolving that the Flint City Council approves the recommendation by Mayor Sheldon A. Neeley to appoint Michael Brown as the Director of the Department of Public Works (DPW). [NOTE: Mr. Brown will be paid an annual compensation rate of \$95,000.00 (45.673 per hour).]

**RECONSIDERED**

## APPOINTMENTS

210123            Mayoral Appointment/Department of Public Works (DPW) Director/Michael Brown

Resolution resolving that the Flint City Council approves the recommendation by Mayor Sheldon A. Neeley to appoint Michael Brown as the Director of the Department of Public Works (DPW). [NOTE: Mr. Brown will be paid an annual compensation rate of \$95,000.00 (45.673 per hour).]

**A motion was made by Councilperson Griggs, seconded by Councilperson Davis, that this matter be Amended. The motion carried by the following vote:**

**Aye:** 8 - Councilperson Mays, Councilperson Davis, Councilperson Guerra, Councilperson Fields, Councilperson Winfrey-Carter, Councilperson Winfrey, Councilperson Griggs and Councilperson Worthing

**Absent:** 1 - Councilperson Galloway

210123.1            Amendment/Mayoral Appointment/Department of Public Works (DPW) Director/Michael Brown

Amended resolution resolving that the Flint City Council approves the recommendation by Mayor Sheldon A. Neeley to appoint Michael Brown as the Director of the Department of Public Works (DPW). [NOTE: Mr. Brown will be paid an annual compensation rate of \$95,000.00 (45.673 per hour).] [NOTE: Resolution amended to include permanent Terms of Appointment and that salary is retroactive to 3-1-21.]

**A motion was made by Councilperson Griggs, seconded by Councilperson Winfrey, that this matter be Adopted. The motion carried by the following vote:**

**Aye:** 7 - Councilperson Davis, Councilperson Guerra, Councilperson Fields, Councilperson Winfrey-Carter, Councilperson Winfrey, Councilperson Griggs and Councilperson Worthing

**Abstain:** 1 - Councilperson Mays

**Absent:** 1 - Councilperson Galloway

**210102**            Mayoral Appointment/Chief Financial Officer/Shelbi Frayer

Resolution resolving that the Flint City Council approves the recommendation by Mayor Sheldon Neeley to appoint Shelbi Frayer as Chief Financial Officer [at an hourly compensation rate of \$71.153 per hour (\$148,100.00 annually).] [General Fund Salary and Wages Acct. No. 101-191.100-703.000 = \$91,976.90 and LCSM-17-FRTA = \$56,032.10.]

**Adopted**

**210166**            Appointment/Human Relations Commission/Sharon M. Bradley/6th Ward

Resolution resolving that the Flint City Council approves the appointment of Sharon M. Bradley (333 Ferndale Place, Flint, MI, 48503), to serve on the City of Flint Human Relations Commission for a one-year term, commencing October 27, 2020, and expiring October 28, 2021.

**A motion was made by Councilperson Winfrey, seconded by Councilperson Davis, that this matter be Approved. The motion carried by the following vote:**

**Aye:** 8 - Councilperson Mays, Councilperson Davis, Councilperson Guerra, Councilperson Fields, Councilperson Winfrey-Carter, Councilperson Winfrey, Councilperson Griggs and Councilperson Worthing

**Absent:** 1 - Councilperson Galloway

## **RECONSIDERATION (of Resolutions)**

**210081**            CO#1/Contract/Rowe Professional Services Co./Project Management Services/FAST Start Program Phase VI

Resolution resolving that the proper city officials, upon City Council's approval, are hereby authorized to enter into change order #1 with Rowe Professional Services Co. for additional project management services for Phase VI of the FAST Start Program, as requested by DPW, in an amount NOT-TO-EXCEED \$500,000.00, for a total contract price NOT-TO-EXCEED \$2,638,735.00 [Water Infrastructure Improvements for the Nation (WIIN) Grant Acct. No. 496-540.006-801.051.]

**A motion was made by Councilperson Davis, seconded by Councilperson Worthing, that this matter be RECONSIDERED. The motion carried by the following vote:**

**Aye:** 7 - Councilperson Davis, Councilperson Guerra, Councilperson Fields, Councilperson Winfrey-Carter, Councilperson Winfrey, Councilperson Griggs and Councilperson Worthing

**Abstain:** 1 - Councilperson Mays

**Absent:** 1 - Councilperson Galloway

## RESOLUTIONS

**210081** CO#1/Contract/Rowe Professional Services Co./Project Management Services/FAST Start Program Phase VI

Resolution resolving that the proper city officials, upon City Council's approval, are hereby authorized to enter into change order #1 with Rowe Professional Services Co. for additional project management services for Phase VI of the FAST Start Program, as requested by DPW, in an amount NOT-TO-EXCEED \$500,000.00, for a total contract price NOT-TO-EXCEED \$2,638,735.00 [Water Infrastructure Improvements for the Nation (WIIN) Grant Acct. No. 496-540.006-801.051.]

**A motion was made by Councilperson Davis, seconded by Councilperson Griggs, that this matter be Adopted. The motion carried by the following vote:**

**Aye:** 6 - Councilperson Davis, Councilperson Guerra, Councilperson Fields, Councilperson Winfrey, Councilperson Griggs and Councilperson Worthing

**Abstain:** 2 - Councilperson Mays and Councilperson Winfrey-Carter

**Absent:** 1 - Councilperson Galloway

**200493** Approval/Emergency Amended Rules Governing Meetings of the Flint City Council

Resolution resolving that the Flint City Council approves the attached amendments to the [Rules Governing Meetings of the Flint City Council], for 60 days, with immediate effect.

### SEPARATED FROM MASTER RESOLUTION

**210144** Licensing Renewal/Dell Marketing LP/Microsoft

Resolution resolving that the proper city officials, upon City Council's approval, are hereby authorized to issue a purchase order to Dell Marketing LP for Microsoft License renewal, as requested by Information Services, in an amount NOT-TO-EXCEED \$86,557.67 [Information Services Fund Acct. No. 636-228.100-814.600.] [NOTE: This is the third year of a three-year agreement.]

**This Matter was ADOPTED BY THE MASTER RESOLUTION on the Consent Agenda.**

**210145** J&M Tree Service/Additional Tree Work/City Parks

Resolution resolving that the proper city officials, upon City Council's approval, are authorized to do all things necessary to increase to total contracted amount with J&M Tree Service for additional tree work needed in city parks, as requested by Parks & Recreation, in an amount NOT-TO-EXCEED \$10,000.00 [Parks & Recreation Fund Professional Services Acct. No. 208-752.102-801.000]. [NOTE: The additional work needed total \$10,000.00 and would be set up as a new purchase order for emergency tree removal and trimming in parks.]

#### SEPARATED FROM MASTER RESOLUTION

**210146** Contract/Platinum Mechanical, Inc./Sludge Storage Pipe Fabrication Project

Resolution resolving that the appropriate city officials, upon City Council's approval, are authorized to do all things necessary to issue a contract to Platinum Mechanical, Inc. for a Sludge Storage Pipe Fabrication project, as requested by DPW, in an amount NOT-TO-EXCEED \$131,477.00 [Sewer Fund Building Additions & Improvements Acct. No. 590-550.300-976-000.]

**This Matter was ADOPTED BY THE MASTER RESOLUTION on the Consent Agenda.**

**210147** Settlement/Stacy Swimp v Mary Buszek et al/Case No. 2:18-cv-11914

Resolution resolving that the City Administrator hereby authorizes settlement, in the matter of Stacy Swimp v Mary Buszek et al, Case No. 2:18-cv-11914, in the amount of \$79,500.00, in satisfaction of any and all claims arising out of said matter, with payment drawn from appropriated funds in the Litigation and Suits Line Item No. 677-266.200-956.300. [NOTE: An Executive Session was requested on this matter on March 8, 2021.]

**This Matter was ADOPTED BY THE MASTER RESOLUTION on the Consent Agenda.**

**210148** Payment/Settlement Agreement/Mackinac Center for Public Policy v City of Flint/Case No. 21-115412-CZ

Resolution resolving that the City Administrator is hereby authorized to pay the settlement offer in the matter of Mackinac Center for Public Policy v City of Flint, in the amount of \$175.00, in satisfaction of any and all claims arising out of said matter, with payment drawn from appropriated funds in the Litigation and Suits Line Item No. 677-266.200-956.300. [NOTE: An Executive Session was held on this matter on February 8, 2021.]

**This Matter was ADOPTED BY THE MASTER RESOLUTION on the Consent Agenda.**

**210149** Name Change/12th Street Garage/Betty Wideman Building

Resolution resolving that the Flint City Council hereby authorizes the renaming of the 12th Street Garage, located at 702 West Twelfth Street, Flint, to The Betty Wideman Building. [NOTE: Betty Wideman began her career at the City of Flint

in 1994, starting in the Police Department, and ending as Transportation Division Manager. Tragically, she passed away in November 2020.]

**SEPARATED FROM MASTER RESOLUTION**

- 210150** Approval/Street Vacation/Decker Street Between Robert T. Longway Boulevard and Kearsley Street

Resolution resolving that Decker Street Between Robert T. Longway Boulevard and Kearsley Street is hereby vacated and discontinued forever as a public street, alley or public ground, and the same is hereby placed on the assessment rolls for the purpose of taxation; AND, resolving that the City Clerk shall, within 30 days of this action, record a certified copy of this resolution with the Register of Deeds for Genesee County and forward a certified copy of said resolution to the State Treasurer. [NOTE: The Ruth Mott Foundation's Applewood Master Plan calls for the construction of a welcome center... which will offer year-round education, conference and exhibit spaces open to the community and broader access to the archives and collection materials that are part of the foundation.]

**SEPARATED FROM MASTER RESOLUTION**

- 210151** Approval/Street Vacation/Kearsley Street Between Walnut Street and Robert T. Longway Boulevard (1400 Kearsley Street)

Resolution resolving that Kearsley Street between Walnut Street and Robert T. Longway Boulevard is hereby vacated and discontinued forever as a public street, alley or public ground, and the same is hereby placed on the assessment rolls for the purpose of taxation; AND, resolving that the City Clerk shall, within 30 days of this action, record a certified copy of this resolution with the Register of Deeds for Genesee County and forward a certified copy of said resolution to the State Treasurer. [NOTE: The Ruth Mott Foundation's Applewood Master Plan calls for the construction of a welcome center... which will offer year-round education, conference and exhibit spaces open to the community and broader access to the archives and collection materials that are part of the foundation.]

**SEPARATED FROM MASTER RESOLUTION**

- 210152** Setting a Public Hearing/Brownfield Redevelopment Plan/James P. Cole Project (1809 James P. Cole)

Resolution resolving that the Flint City Council will hold a public hearing at 5:30 p.m. in the City Council Chambers, or electronically in accordance with Gov. Whitmer's Executive Order 2020-75, on the \_\_\_\_\_ day of \_\_\_\_\_ 2021, AND, resolving that the governing body shall provide notice of the hearing to the taxing jurisdictions that levy taxes subject to capture under this Act, and shall fully inform the taxing jurisdictions about the fiscal and economic implications of the proposed Brownfield Plan.

**SEPARATED FROM MASTER RESOLUTION**

**210153** Support/Application/Michigan Department of Transportation (MDOT)/Transportation Alternatives Program (TAP)/Development/Grand Traverse Greenway Trail

Resolution resolving that the appropriate City of Flint officials are authorized to do all things necessary to demonstrate its public support of the city's application to the Michigan Department of Transportation's Transportation Alternatives Program for the Grand Traverse Greenway project and commits to the requirements [of the program.] [NOTE: The city is planning to redevelop abandoned railroad property into a shared use non-motorized paved trail called the Grand Traverse Greenway. Planning & Development has prepared a competitive application to the TAP program requesting \$1,804,825.00 from MDOT-TAP, which the city expects to be matched at \$860,000.00 (32 percent of total project costs) through public and private sources to be finalized before the grant award).

**This Matter was ADOPTED BY THE MASTER RESOLUTION on the Consent Agenda.**

**210159** Submission/2020-2021 Annual Action Plan of the Consolidated Plan

Resolution resolving that city officials approve the funding amounts and projects and authorize entering into contracts for the agencies noted for the City of Flint's FY2020-2021 Community Development Block Grant (CDBG) Program, in the amount of \$3,984,754.00, FY2020-2021 HOME Investment Partnership (HOME) Program, in the amount of \$876,146.00, and FY2020-2021 Emergency Solutions Grant (ESG) Program, in the amount of \$341,765.00, and include any program income which might become available as a result of receipt of these funds.

**SEPARATED FROM MASTER RESOLUTION**

**210163** Approval/Deficit Elimination Plan/Downtown Development Authority (DDA)/Self-Insurance Fund

Resolution resolving that the City Council approves the Deficit Elimination Plan as outlined. The City of Flint's Chief Financial Officer is authorized to do all things necessary to submit the Deficit Elimination Plan to the Michigan Department of Treasury for certification. [NOTE: The Downtown Development Authority has a deficit balance of \$138,003.00 as of June 30, 2020. Any costs not covered by the DDA will be covered by the city's General Fund. And the Self-Insurance Fund incurred numerous expenses related to insurance and legal costs, putting it in the red by \$922,563.00, as of June 30, 2020.]

**SEPARATED FROM MASTER RESOLUTION**

**210164** Easement Agreement/Genesee County Drain Commission (GCDC)/North Dort Highway Property at Frances Road

Resolution resolving that the Flint City Council approves the grant of a permanent non-exclusive easement to the Genesee County Drain Commission to own, operate

and maintain the GCDC FL-02 Meter Facility for valuable consideration in the amount of \$1.00 to be paid to the City of Flint. [NOTE: The City of Flint entered into a Master Agreement on December 1, 2017, to build a secondary water source. The City of Flint has agreed to grant an easement to the GCDC on the city-owned property on North Dort Highway at Frances Road for valuable consideration in the amount of \$1.00.]

#### SEPARATED FROM MASTER RESOLUTION

**210165** Easement Agreement/Great Lakes Water Authority (GLWA)/North Dort Highway Property at Frances Road

Resolution resolving that the Flint City Council approves the grant of a permanent non-exclusive easement to the Great Lakes Water Authority (GLWA) to construct, operate, maintain, repair and/or replace the GLWA water main pipe for valuable consideration in the amount of \$1.00 to be paid to the City of Flint. [NOTE: The City of Flint entered into a Master Agreement on December 1, 2017, to build a secondary water source. The City of Flint has agreed to grant an easement to GLWA on the city-owned property on North Dort Highway at Frances Road for valuable consideration in the amount of \$1.00.]

#### SEPARATED FROM MASTER RESOLUTION

### Passed The Consent Agenda

**A motion was made by Councilperson Winfrey, seconded by Councilperson Davis, including all the preceding items marked as having been adopted on a Consent Agenda. The motion carried by the following vote:**

**Aye:** 8 - Councilperson Mays, Councilperson Davis, Councilperson Guerra, Councilperson Fields, Councilperson Winfrey-Carter, Councilperson Winfrey, Councilperson Griggs and Councilperson Worthing

**Absent:** 1 - Councilperson Galloway

### SEPARATED FROM THE MASTER RESOLUTION

**200493** Approval/Emergency Amended Rules Governing Meetings of the Flint City Council

Resolution resolving that the Flint City Council approves the attached amendments to the [Rules Governing Meetings of the Flint City Council], for 60 days, with immediate effect.

**A motion was made by Councilperson Mays, seconded by Councilperson Winfrey-Carter, that this matter be REFERRED TO COMMITTEE to the AD HOC COMMITTEE ON RULES GOVERNING MEETINGS OF THE COUNCIL. The motion failed by the following vote:**

**Aye:** 3 - Councilperson Mays, Councilperson Winfrey-Carter and Councilperson Winfrey

**No:** 5 - Councilperson Davis, Councilperson Guerra, Councilperson Fields, Councilperson Griggs and Councilperson Worthing



**Absent:** 1 - Councilperson Galloway

## ROLL CALL

*Councilperson Mays was removed from the meeting (muted) around 10:10 p.m.*

**Present:** Councilperson: Councilperson Davis, Councilperson Guerra, Councilperson Fields, Councilperson Winfrey-Carter, Winfrey, Councilperson Griggs and Councilperson Worthing

**Absent:** Councilperson: Councilperson Mays and Councilperson Galloway

## SEPARATED FROM THE MASTER RESOLUTION CONTINUED

**200493** Approval/Emergency Amended Rules Governing Meetings of the Flint City Council

Resolution resolving that the Flint City Council approves the attached amendments to the [Rules Governing Meetings of the Flint City Council], for 60 days, with immediate effect.

**A motion was made by Councilperson Davis, seconded by Councilperson Worthing, that this matter be Adopted. The motion carried by the following vote:**

**Aye:** 5 - Councilperson Davis, Councilperson Guerra, Councilperson Fields, Councilperson Griggs and Councilperson Worthing

**No:** 2 - Councilperson Winfrey-Carter and Councilperson Winfrey

**Absent:** 2 - Councilperson Mays and Councilperson Galloway

**210145** J&M Tree Service/Additional Tree Work/City Parks

Resolution resolving that the proper city officials, upon City Council's approval, are authorized to do all things necessary to increase to total contracted amount with J&M Tree Service for additional tree work needed in city parks, as requested by Parks & Recreation, in an amount NOT-TO-EXCEED \$10,000.00 [Parks & Recreation Fund Professional Services Acct. No. 208-752.102-801.000]. [NOTE: The additional work needed total \$10,000.00 and would be set up as a new purchase order for emergency tree removal and trimming in parks.]

**A motion was made by Councilperson Davis, seconded by Councilperson Griggs, that this matter be Adopted. The motion carried by the following vote:**

**Aye:** 7 - Councilperson Davis, Councilperson Guerra, Councilperson Fields, Councilperson Winfrey-Carter, Councilperson Winfrey, Councilperson Griggs and Councilperson Worthing

**Absent:** 2 - Councilperson Mays and Councilperson Galloway

**210149** Name Change/12th Street Garage/Betty Wideman Building

Resolution resolving that the Flint City Council hereby authorizes the renaming of the 12th Street Garage, located at 702 West Twelfth Street, Flint, to The Betty

Wideman Building. [NOTE: Betty Wideman began her career at the City of Flint in 1994, starting in the Police Department, and ending as Transportation Division Manager. Tragically, she passed away in November 2020.]

**A motion was made by Councilperson Davis, seconded by Councilperson Griggs, that this matter be Adopted. The motion carried by the following vote:**

**Aye:** 7 - Councilperson Davis, Councilperson Guerra, Councilperson Fields, Councilperson Winfrey-Carter, Councilperson Winfrey, Councilperson Griggs and Councilperson Worthing

**Absent:** 2 - Councilperson Mays and Councilperson Galloway

210150

Approval/Street Vacation/Decker Street Between Robert T. Longway Boulevard and Kearsley Street

Resolution resolving that Decker Street Between Robert T. Longway Boulevard and Kearsley Street is hereby vacated and discontinued forever as a public street, alley or public ground, and the same is hereby placed on the assessment rolls for the purpose of taxation; AND, resolving that the City Clerk shall, within 30 days of this action, record a certified copy of this resolution with the Register of Deeds for Genesee County and forward a certified copy of said resolution to the State Treasurer. [NOTE: The Ruth Mott Foundation's Applewood Master Plan calls for the construction of a welcome center... which will offer year-round education, conference and exhibit spaces open to the community and broader access to the archives and collection materials that are part of the foundation.]

**A motion was made by Councilperson Winfrey, seconded by Councilperson Griggs, that this matter be Adopted. The motion carried by the following vote:**

**Aye:** 7 - Councilperson Davis, Councilperson Guerra, Councilperson Fields, Councilperson Winfrey-Carter, Councilperson Winfrey, Councilperson Griggs and Councilperson Worthing

**Absent:** 2 - Councilperson Mays and Councilperson Galloway

210151

Approval/Street Vacation/Kearsley Street Between Walnut Street and Robert T. Longway Boulevard (1400 Kearsley Street)

Resolution resolving that Kearsley Street between Walnut Street and Robert T. Longway Boulevard is hereby vacated and discontinued forever as a public street, alley or public ground, and the same is hereby placed on the assessment rolls for the purpose of taxation; AND, resolving that the City Clerk shall, within 30 days of this action, record a certified copy of this resolution with the Register of Deeds for Genesee County and forward a certified copy of said resolution to the State Treasurer. [NOTE: The Ruth Mott Foundation's Applewood Master Plan calls for the construction of a welcome center... which will offer year-round education, conference and exhibit spaces open to the community and broader access to the archives and collection materials that are part of the foundation.]

**A motion was made by Councilperson Winfrey, seconded by Councilperson Griggs, that this matter be Adopted. The motion carried by the following vote:**

**Aye:** 7 - Councilperson Davis, Councilperson Guerra, Councilperson Fields, Councilperson Winfrey-Carter, Councilperson Winfrey, Councilperson Griggs and Councilperson Worthing

**Absent:** 2 - Councilperson Mays and Councilperson Galloway

**210152** Setting a Public Hearing/Brownfield Redevelopment Plan/James P. Cole Project (1809 James P. Cole)

Resolution resolving that the Flint City Council will hold a public hearing at 5:30 p.m. in the City Council Chambers, or electronically in accordance with Gov. Whitmer's Executive Order 2020-75, on the \_\_\_\_\_ day of \_\_\_\_\_ 2021, AND, resolving that the governing body shall provide notice of the hearing to the taxing jurisdictions that levy taxes subject to capture under this Act, and shall fully inform the taxing jurisdictions about the fiscal and economic implications of the proposed Brownfield Plan.

**A motion was made by Councilperson Davis, seconded by Councilperson Worthing, that this matter be REFERRED TO COMMITTEE to the GOVERNMENTAL OPERATIONS COMMITTEE, due back on April 21, 2021. The motion carried by the following vote:**

**Aye:** 5 - Councilperson Guerra, Councilperson Winfrey-Carter, Councilperson Winfrey, Councilperson Griggs and Councilperson Worthing

**No:** 2 - Councilperson Davis and Councilperson Fields

**Absent:** 2 - Councilperson Mays and Councilperson Galloway

**210159** Submission/2020-2021 Annual Action Plan of the Consolidated Plan

Resolution resolving that city officials approve the funding amounts and projects and authorize entering into contracts for the agencies noted for the City of Flint's FY2020-2021 Community Development Block Grant (CDBG) Program, in the amount of \$3,984,754.00, FY2020-2021 HOME Investment Partnership (HOME) Program, in the amount of \$876,146.00, and FY2020-2021 Emergency Solutions Grant (ESG) Program, in the amount of \$341,765.00, and include any program income which might become available as a result of receipt of these funds.

**A motion was made by Councilperson Davis, seconded by Councilperson Worthing, that this matter be Adopted. The motion carried by the following vote:**

**Aye:** 6 - Councilperson Davis, Councilperson Guerra, Councilperson Fields, Councilperson Winfrey, Councilperson Griggs and Councilperson Worthing

**No:** 1 - Councilperson Winfrey-Carter

**Absent:** 2 - Councilperson Mays and Councilperson Galloway

**210163** Approval/Deficit Elimination Plan/Downtown Development Authority (DDA)/Self-Insurance Fund

Resolution resolving that the City Council approves the Deficit Elimination Plan

as outlined. The City of Flint's Chief Financial Officer is authorized to do all things necessary to submit the Deficit Elimination Plan to the Michigan Department of Treasury for certification. [NOTE: The Downtown Development Authority has a deficit balance of \$138,003.00 as of June 30, 2020. Any costs not covered by the DDA will be covered by the city's General Fund. And the Self-Insurance Fund incurred numerous expenses related to insurance and legal costs, putting it in the red by \$922,563.00, as of June 30, 2020.]

**A motion was made by Councilperson Griggs, seconded by Councilperson Davis, that this matter be Adopted. The motion carried by the following vote:**

**Aye:** 7 - Councilperson Davis, Councilperson Guerra, Councilperson Fields, Councilperson Winfrey-Carter, Councilperson Winfrey, Councilperson Griggs and Councilperson Worthing

**Absent:** 2 - Councilperson Mays and Councilperson Galloway

## ROLL CALL

*Councilperson Winfrey-Carter left the meeting around 11:30 p.m.*

**Present:** Councilperson: Councilperson Davis, Councilperson Guerra, Councilperson Fields, Winfrey, Councilperson Griggs and Councilperson Worthing

**Absent:** Councilperson: Councilperson Mays, Councilperson Winfrey-Carter and Councilperson Galloway

210164

Easement Agreement/Genesee County Drain Commission (GCDC)/North Dort Highway Property at Frances Road

Resolution resolving that the Flint City Council approves the grant of a permanent non-exclusive easement to the Genesee County Drain Commission to own, operate and maintain the GCDC FL-02 Meter Facility for valuable consideration in the amount of \$1.00 to be paid to the City of Flint. [NOTE: The City of Flint entered into a Master Agreement on December 1, 2017, to build a secondary water source. The City of Flint has agreed to grant an easement to the GCDC on the city-owned property on North Dort Highway at Frances Road for valuable consideration in the amount of \$1.00.]

**A motion was made by Councilperson Davis, seconded by Councilperson Griggs, that this matter be Adopted. The motion carried by the following vote:**

**Aye:** 6 - Councilperson Davis, Councilperson Guerra, Councilperson Fields, Councilperson Winfrey, Councilperson Griggs and Councilperson Worthing

**Absent:** 3 - Councilperson Mays, Councilperson Winfrey-Carter and Councilperson Galloway

210165

Easement Agreement/Great Lakes Water Authority (GLWA)/North Dort Highway Property at Frances Road

Resolution resolving that the Flint City Council approves the grant of a permanent non-exclusive easement to the Great Lakes Water Authority (GLWA) to construct, operate, maintain, repair and/or replace the GLWA water main pipe for valuable consideration in the amount of \$1.00 to be paid to the City of Flint. [NOTE: The City of Flint entered into a Master Agreement on December 1, 2017, to build a

secondary water source. The City of Flint has agreed to grant an easement to GLWA on the city-owned property on North Dort Highway at Frances Road for valuable consideration in the amount of \$1.00.]

**A motion was made by Councilperson Davis, seconded by Councilperson Griggs, that this matter be Adopted. The motion carried by the following vote:**

**Aye:** 6 - Councilperson Davis, Councilperson Guerra, Councilperson Fields, Councilperson Winfrey, Councilperson Griggs and Councilperson Worthing

**Absent:** 3 - Councilperson Mays, Councilperson Winfrey-Carter and Councilperson Galloway

## LIQUOR LICENSES

## INTRODUCTION AND FIRST READING OF ORDINANCES

**210158** Amendment/Ordinance/Chapter 18 (Taxation; Funds; Purchasing)/Article I (In General)/Section 18-4.1 (Service Charge in Lieu of Taxes for Housing Facilities for Certain Persons)

The provisions of Chapter 18, (Taxation; Funds; Purchasing); Article I, (In General); Section 18-4.1, (Service Charge in Lieu of Taxes for Housing Facilities for Certain Persons) shall be amended by adding subsection (GG). [NOTE: The PILOT is for Flushing Place Limited Dividend Housing Association, LP, a Limited Partnership. The annual service charge for the class of persons of low and moderate income shall be equal to four (4) percent of the annual shelter rents, exclusive of charges for gas, electricity, heat or other utilities furnished to the occupants.]

**A motion was made by Councilperson Davis, seconded by Councilperson Worthing, that this matter be ACKNOWLEDGED FOR FIRST READING. The motion carried by the following vote:**

**Aye:** 6 - Councilperson Davis, Councilperson Guerra, Councilperson Fields, Councilperson Winfrey, Councilperson Griggs and Councilperson Worthing

**Absent:** 3 - Councilperson Mays, Councilperson Winfrey-Carter and Councilperson Galloway

## SECOND READING AND ENACTMENT OF ORDINANCES

**210044** Ordinance/Chapter 50 (Zoning)/Article I (In General)

An ordinance to amend Chapter 50 (Zoning), Article I, (In General), of the Code of the City of Flint by repealing said Article and adopting Article I (Title, Purpose and Scope). [NOTE: This Chapter shall be known as the "Zoning Ordinance" of the City of Flint.]

*One motion was made to approve for Second Reading and Adoption the following: 210044, 210045.1, 210046, 210047, 210048, 210049 and 210085.*

**A motion was made by Councilperson Griggs, seconded by Councilperson Worthing, that this matter be PASSED. The motion carried by the following vote:**

**Aye:** 5 - Councilperson Guerra, Councilperson Fields, Councilperson Winfrey, Councilperson Griggs and Councilperson Worthing

**No:** 1 - Councilperson Davis

**Absent:** 3 - Councilperson Mays, Councilperson Winfrey-Carter and Councilperson Galloway

**210045.1** Amendment/Ordinance/Chapter 50 (Zoning)/Article II (A-1 Single-Family Low-Density District)

An amended ordinance amending Chapter 50 (Zoning), Article II, (A-1 Single-Family Low-Density District), of the Code of the City of Flint by repealing said Article and adopting Article II (Mapped Zone Districts). [NOTE: Ordinance amended to correct the zoning of addresses 914 and 918 East Kearsley Street, Parcel Nos. 41-07-453-016 and 41-07-453-017. They are mapped as MR-2 and should be mapped as MR-1 to be consistent with the other addresses in the neighborhood.]

**A motion was made by Councilperson Griggs, seconded by Councilperson Worthing, that this matter be PASSED. The motion carried by the following vote:**

**Aye:** 5 - Councilperson Guerra, Councilperson Fields, Councilperson Winfrey, Councilperson Griggs and Councilperson Worthing

**No:** 1 - Councilperson Davis

**Absent:** 3 - Councilperson Mays, Councilperson Winfrey-Carter and Councilperson Galloway

**210046** Ordinance/Chapter 50 (Zoning)/Article III (A-2 Single-Family Medium Density District)

An ordinance to amend Chapter 50 (Zoning), Article III, (A-2 Single-Family Medium Density District), of the Code of the City of Flint by repealing said Article and adopting Article III (Residential Zone Districts).

**A motion was made by Councilperson Griggs, seconded by Councilperson Worthing, that this matter be PASSED. The motion carried by the following vote:**

**Aye:** 5 - Councilperson Guerra, Councilperson Fields, Councilperson Winfrey, Councilperson Griggs and Councilperson Worthing

**No:** 1 - Councilperson Davis

**Absent:** 3 - Councilperson Mays, Councilperson Winfrey-Carter and Councilperson Galloway

**210047** Ordinance/Chapter 50 (Zoning)/Article IV (B Two-Family District)

An ordinance to amend Chapter 50 (Zoning), Article IV, (B Two-Family District), of the Code of the City of Flint by repealing said Article and adopting Article IV (Commercial Zone Districts).

**A motion was made by Councilperson Griggs, seconded by Councilperson Worthing, that this matter be PASSED. The motion carried by the following vote:**

**Aye:** 5 - Councilperson Guerra, Councilperson Fields, Councilperson Winfrey, Councilperson Griggs and Councilperson Worthing

**No:** 1 - Councilperson Davis

**Absent:** 3 - Councilperson Mays, Councilperson Winfrey-Carter and Councilperson Galloway

**210048** Ordinance/Chapter 50 (Zoning)/Article V (C-1 Multifamily Walk-Up Apartment District)

An ordinance to amend Chapter 50 (Zoning), Article V, (C-1 Multifamily Walk-Up Apartment District), of the Code of the City of Flint by repealing said Article and adopting Article V (Employment Zone Districts).

**A motion was made by Councilperson Griggs, seconded by Councilperson Worthing, that this matter be PASSED. The motion carried by the following vote:**

**Aye:** 5 - Councilperson Guerra, Councilperson Fields, Councilperson Winfrey, Councilperson Griggs and Councilperson Worthing

**No:** 1 - Councilperson Davis

**Absent:** 3 - Councilperson Mays, Councilperson Winfrey-Carter and Councilperson Galloway

**210049** Ordinance/Chapter 50 (Zoning)/Article VI (C-2 Multifamily High-Density Apartment District)

An ordinance to amend Chapter 50 (Zoning), Article VI, (C-2 Multifamily High-Density Apartment District), of the Code of the City of Flint by repealing said Article and adopting Article VI (Institutional/Innovation Zoned Districts).

**A motion was made by Councilperson Griggs, seconded by Councilperson Worthing, that this matter be PASSED. The motion carried by the following vote:**

**Aye:** 5 - Councilperson Guerra, Councilperson Fields, Councilperson Winfrey, Councilperson Griggs and Councilperson Worthing

**No:** 1 - Councilperson Davis

**Absent:** 3 - Councilperson Mays, Councilperson Winfrey-Carter and Councilperson Galloway

**210085** Ordinance/Amendment/Chapter 18 (Taxation; Funds; Purchasing)/Article II (Assessments)/Amendment of Sections 18-7, 18-8, 18-9 and 18-10

An ordinance to amend the Flint City Code of Ordinances by amending Chapter 18 (Taxation; Funds; Purchasing), Article II (Assessments), by amending Section 18-7 (Special Assessment Relief Board Created; Membership), by amending Section 18-8 (Same -- Investigation of Requests for Relief; Report and Recommendation), by amending Section 18-9 (Award of Relief from Assessments), and by amending Section 18-10 (Payment of Special Assessment by City; Taking of Mortgage and Note to Assure Repayment to City.)

A motion was made by Councilperson Griggs, seconded by Councilperson Worthing, that this matter be PASSED. The motion carried by the following vote:

**Aye:** 5 - Councilperson Guerra, Councilperson Fields, Councilperson Winfrey, Councilperson Griggs and Councilperson Worthing

**No:** 1 - Councilperson Davis

**Absent:** 3 - Councilperson Mays, Councilperson Winfrey-Carter and Councilperson Galloway

## DISCUSSION ITEMS

**210168** Discussion Item/Codification of Ordinances

A Discussion Item as requested by Councilperson Fields to discuss codification of ordinances.

**REFERRED TO COMMITTEE to the GOVERNMENTAL OPERATIONS COMMITTEE**

## MOTION

*Councilperson Worthing, with support from Councilperson Griggs, made a motion to authorize hiring an outside firm to codify and get ordinances up-to-date. Councilperson Guerra made a substitute motion, with support from Councilperson Worthing, to move this discussion item to the next Governmental Operations Committee (4-21-21) with a resolution attached. The motion passed 5-1 (No: Davis).*

**210169** Discussion Item/Zoning Ordinances

A Discussion Item as requested by Councilperson Fields on zoning ordinances.

**DROPPED**

**210170** Discussion Item/Threats to Staff

A Discussion Item as requested by Councilperson Fields to discuss threats to staff.

**DROPPED**

## SPECIAL ORDERS

*Councilperson Guerra, with support from Councilperson Worthing, made a motion to postpone all Special Orders to the next City Council meeting (4-26-21). The motion passed 6-0.*

**210070** Special Order/Hatch Act

A Special Order as requested by Council President Fields to discuss the Hatch Act of 1939, which prohibits some forms of political activity.

**210124** Special Order/Bone Scans & Lead Measurement/Dr. Lawrence Reynolds



A Special Order as requested by Council President Fields to allow Dr. Lawrence Reynolds to present his findings on bone scanning equipment and their use in measuring lead exposure.

**210167** Special Order/Special Orders

A Special Order as requested by Council President Fields to discuss Special Orders.

**210171** Special Order/Special Meeting/\$99 Million/COVID-19 Relief Funds

A Special Order as requested by Councilperson Mays to discuss having a special meeting to talk about the \$99 million in COVID-19 relief funds.

**210172** Special Order/Discussion/Finance Committee Vice Chair

A Special Order as requested by Councilperson Worthing to discuss the Finance Committee Vice Chair.

## **ADJOURNMENT**

*This meeting adjourned at 12:55 a.m. after a motion by Councilperson Griggs, with support from Councilperson Worthing. The motion passed 5-0 (Absent: Mays, Davis, Winfrey-Carter, Galloway).*

*Respectfully transcribed & submitted,*

*Janell Johnson, Administrative Secretary to City Council*

# City of Flint, Michigan

*Third Floor, City Hall  
1101 S. Saginaw Street  
Flint, Michigan 48502  
www.cityofflint.com*



## Meeting Minutes - Draft

Monday, April 26, 2021

6:44 PM

\*

**ELECTRONIC PUBLIC MEETING**

## CITY COUNCIL

*Kate Fields, President, Ward 4*

*Maurice D. Davis, Vice President, Ward 2*

*Eric Mays, Ward 1*

*Jerri Winfrey-Carter, Ward 5*

*Monica Galloway, Ward 7*

*Santino J. Guerra, Ward 3*

*Herbert J. Winfrey, Ward 6*

*Allan Griggs, Ward 8*

*Eva L. Worthing, Ward 9*

*Inez M. Brown, City Clerk*

*Davina Donahue, Deputy Clerk*

## CALL TO ORDER

*Council President Kate Fields called the meeting to order at 6:44 p.m.*

## ROLL CALL

**Present:** Councilperson: Councilperson Mays, Councilperson Davis, Councilperson Guerra, Councilperson Fields, Councilperson Winfrey-Carter, Winfrey, Councilperson Galloway, Councilperson Griggs and Councilperson Worthing

## PLEDGE OF ALLEGIANCE

*Councilperson Maurice Davis led the Pledge of Allegiance.*

## REQUEST FOR CHANGES AND/OR ADDITIONS TO AGENDA

*Councilperson Winfrey made a motion to have Presentation of Minutes, Public Speaking, Council Response, Resolutions, Appointments and Special Orders, in that order. The vote was 9-0. Councilperson Fields asked to postpone Special Orders 210167 (Special Orders) and 210124 (Bone Scans and Lead Measurements). The vote was 9-0. Councilperson Fields made a motion to postpone Special Order 210070 (Hatch Act). The vote was 5-4 (No: Mays, Winfrey-Carter, Winfrey, Galloway). Councilperson Galloway asked to have a Special Order on Republic Services about composting and trash services as the first Special Order. The vote was 7-2 (No: Griggs, Worthing).*

## PRESENTATION OF MINUTES

### 210194 Summary Minutes/Flint City Council/January 11, 2021

Summary Minutes of the Flint City Council ELECTRONIC PUBLIC MEETING held Monday, January 11, 2021 at 5:30 p.m.

*The motion by Councilperson Mays, with support from Councilperson Winfrey-Carter, was to place all of the Minutes (210194, 210195 and 210196) on file with any corrections.*

**A motion was made by Councilperson Mays, seconded by Councilperson Winfrey-Carter, that this matter be Placed on File. The motion carried by the following vote:**

**Aye:** 9 - Councilperson Mays, Councilperson Davis, Councilperson Guerra, Councilperson Fields, Councilperson Winfrey-Carter, Councilperson Winfrey, Councilperson Galloway, Councilperson Griggs and Councilperson Worthing

### 210195 Summary Minutes/Flint City Council/January 25, 2021

Summary Minutes of the Flint City Council ELECTRONIC PUBLIC MEETING held Monday, January 25, 2021 at 5:32 p.m.

**A motion was made by Councilperson Mays, seconded by Councilperson Griggs, that this matter be Placed on File. The motion carried by the following vote:**

**Aye:** 9 - Councilperson Mays, Councilperson Davis, Councilperson Guerra, Councilperson Fields, Councilperson Winfrey-Carter, Councilperson Winfrey, Councilperson Galloway, Councilperson Griggs and Councilperson Worthing

**210196** Summary Minutes/Flint City Council/February 22, 2021

Summary Minutes of the Flint City Council ELECTRONIC PUBLIC MEETING held Monday, February 22, 2021 at 6:32 p.m.

**A motion was made by Councilperson Mays, seconded by Councilperson Griggs, that this matter be Placed on File. The motion carried by the following vote:**

**Aye:** 9 - Councilperson Mays, Councilperson Davis, Councilperson Guerra, Councilperson Fields, Councilperson Winfrey-Carter, Councilperson Winfrey, Councilperson Galloway, Councilperson Griggs and Councilperson Worthing

## **PETITIONS AND UNOFFICIAL COMMUNICATIONS**

**210182** Hazard Mitigation Project Requests/Genesee County Metropolitan Planning Commission (GCMPC)

Memorandum dated March 12, 2021 from the Genesee County Metropolitan Planning Commission (GCMPC), GLS Region V Planning and Development Commission, re: Hazard Mitigation Project Requests.

**This Matter was Placed on File on the Consent Agenda.**

**210183** Communication/Michigan Municipal League/Talking Points/American Rescue Plan (ARP)

Communication dated March 23, 2021, from The Michigan Municipal League re: Talking points for the American Rescue Plan for Michigan's Local Governments.

**This Matter was Placed on File on the Consent Agenda.**

**210184** Financial Report/Karegnondi Water Authority (KWA)

Communication received March 25, 2021, re: The Karegnondi Water Authority (KWA) February 2021 Financial Report.

**This Matter was Placed on File on the Consent Agenda.**

**210185** Update/Hazard Mitigation Project Requests/Genesee County Metropolitan Planning Commission (GCMPC)

Memorandum dated March 12, 2021 from the Genesee County Metropolitan Planning Commission (GCMPC), GLS Region V Planning and Development Commission, re: Updates on Hazard Mitigation Project Requests.

**This Matter was Placed on File on the Consent Agenda.**

- 210186** Draft 2021 Genesee County Action Plan/Genesee County Metropolitan Planning Commission (GCMPC)
- Communication dated March 25, 2021, from the Genesee County Metropolitan Planning Commission (GCMPC) to Flint City Clerk, re: A copy of the Draft 2021 Genesee County Action Plan.
- This Matter was Placed on File on the Consent Agenda.**
- 210187** Contracting for Waste and Recycling Services/Genesee County Metropolitan Planning Commission (GCMPC)
- Communication dated March 30, 2021, from the Genesee County Metropolitan Planning Commission (GCMPC) to Flint Mayor, re: Contracting for waste and recycling services.
- This Matter was Placed on File on the Consent Agenda.**
- 210188** Public Notice/Genesee County Metropolitan Alliance (GCMA)
- Communication received April 1, 2021, from the Genesee County Metropolitan Alliance (GCMA), re: The GCMA will have a meeting on Wednesday, April 21, 2021, at 7 p.m., via teleconference, to review and comment on Amendment No. 15 to the FY2020-2023 Transportation Improvement Program (TIP).
- This Matter was Placed on File on the Consent Agenda.**
- 210189** Flint & Genesee Chamber of Commerce/Unveiling of New Name, Logo
- Communication dated April 5, 2021, from the Flint & Genesee Chamber of Commerce, re: The Flint & Genesee Chamber of Commerce unveils new name (Flint & Genesee Chamber) and logo.
- This Matter was Placed on File on the Consent Agenda.**
- 210190** Michigan Department of Treasury/Homestead Property Tax Credit
- Communication received from the Michigan Department of Treasury on April 8, 2021, re: Working families and individuals eligible for Homestead Property Tax Credit.
- This Matter was Placed on File on the Consent Agenda.**
- 210191** Office of Gov. Gretchen Whitmer/Vaccine Content
- Email dated April 8, 2021, from the office of Gov. Gretchen Whitmer, re: Daily vaccine content.
- This Matter was Placed on File on the Consent Agenda.**
- 210192** Communication/Great Lakes Water Authority (GLWA)/FY2020 Wholesale Water

## Schedule of Charges

Communication dated April 5, 2021, from Sue McCormick, Chief Executive Officer of the Great Lakes Water Authority (GLWA), re: FY 2022 wholesale water schedule of charges.

**This Matter was Placed on File on the Consent Agenda.**

**COMMUNICATIONS (from Mayor and other City Officials)****210193** Traffic Engineering/Closure Permits

Sidewalk, Lane and Street Closure permits (16) dated March and April, 2021, for requested activities/events, with noted responsibility for the placement of the required traffic control devices, and/or personnel, for the protection of traffic and event participants.

**This Matter was Placed on File on the Consent Agenda.**

have all matters listed above be Placed on File

**RESOLUTIONS****210174** Siemens Mobility/Additional Eagle Signal Repair Parts & Services

Resolution resolving that the appropriate city officials, upon City Council's approval, are hereby authorized to issue a purchase order to Siemens Mobility for additional Eagle signal repair parts and services, as requested by Transportation, in an amount NOT-TO-EXCEED \$50,000.00, and a total aggregate amount of \$170,000.00 [Major Street Fund Acct. No. 202-443.201-801.000.]

**This Matter was ADOPTED BY THE MASTER RESOLUTION on the Consent Agenda.**

**210175** Weinstein Electric/Electrical Support Services

Resolution resolving that the proper city officials, upon City Council's approval, are hereby authorized to issue a purchase order to Weinstein Electric for additional support services for the City of Flint Oak Business Center under the auspices of the Planning and Development Department, in an amount NOT-TO-EXCEED \$29,310.00, and a revised aggregate amount of \$207,043.00 [Oak Business Center Lighting Acct. No. 583-735.204-801.000 = \$1,120.00; Oak Business Center Lighting Acct. No. 583-735.204-976.000 = \$4,622.00; Oak Business Center Acct. No. 583-735.204-930.000 = \$1,778.00; Oak Business Center Professional Services Acct. No. 583-735.204-801.000 = \$17,000.00; and Oak Business Center Building Additions/Improvements Acct. No. 583-735.204-976.000 = \$4,790.00.]

**This Matter was ADOPTED BY THE MASTER RESOLUTION on the Consent Agenda.**

**210176** Budget Amendment/Transfer of Funds/General Fund/City Clerk's Office/Elections

Resolution resolving that the appropriate city officials, upon City Council's approval, are hereby authorized to do all things necessary to incorporate the approved appropriation changes [totaling \$169,556.28] into the FY2020-FY2021 operating budget of the City of Flint [Election Wages Acct. No. 101-262.110-702.000 = \$45,000.00; Election Wages Acct. No. 101-262.100-702.000 = \$16,489.15; Election Transportation Acct. No. 101-262.100-860.000 = \$5,000.00; Election Rentals Acct. No. 101-262.100-940.000 = \$6,105.00; Election Temp Workers Acct. No. 101-262.110-707.000 = \$27,982.26; Election Overtime Acct. No. 101-262.100-713.000 = \$14,000.00; Election Overtime Acct. No. 101-262.110-713.000 = \$41,979.87; and Election Postage Acct. No. 101-262.100-902.000 = \$13,000.00.] [NOTE: The City Clerk would like to add funds to the line items provided to cover the costs of the May 2021 election. The Clerk also needs additional budget related to the increased costs of the November 2020 election due to the pandemic.]

#### SEPARATED FROM MASTER RESOLUTION

- 210177 Maintenance/Easement/City of Flint Use/North Dort Highway Property/Secondary Water Source

Resolution resolving that the Flint City Council approves retaining a permanent easement on the North Dort Highway property at Frances Road for city use, including, but not limited to, Flint's Secondary Water Source, and the easement will be forever attached to the property.

#### SEPARATED FROM MASTER RESOLUTION

- 210178 Approval/Sign Installation/Whaley Center

Resolution resolving that the appropriate city officials are hereby authorized to do all things necessary to approve the placement of the "Reclaimed by Whaley" sign, located at 141 West Second Street, as requested by Zoning. [NOTE: The sign will be installed to identify the nonprofit organization named Reclaimed by Whaley. This resolution is necessary because the city's Zoning Ordinance requires that the City Council must authorize the placement of signs over public property (Chapter 50-149.9 (c).]

**This Matter was ADOPTED BY THE MASTER RESOLUTION on the Consent Agenda.**

- 210199 Approval/City of Flint Prohibition of Hairstyle-Based Racial Discrimination

Resolution resolving that the City of Flint hereby declares that the term "Race" or "race" as used in city contract's and the city's Title VI, Non-Discrimination Plan, shall be defined as being inclusive of traits historically associated with race, including, but not limited to, hair texture and protective hairstyles. For purposes of this definition, "protective hairstyles" includes, but is not limited to, such hairstyles as braids, locks and twists.

**This Matter was ADOPTED BY THE MASTER RESOLUTION on the Consent Agenda.**

## RESOLUTIONS (May be Referred from Special Affairs)

**210197** Berger Chevrolet, Inc./Twenty (20) 2020 Chevrolet Tahoe Police Pursuit Vehicles

Resolution resolving that the appropriate City Officials are authorized to issue a purchase order to Berger Chevrolet, Inc. for twenty (20) 2019 Chevrolet Tahoe Police Pursuit Vehicles (PPV), with full police up-fitting, as requested by Police, in an amount NOT-TO-EXCEED \$257,877.66 [Fleet/Central Garage Fund Acct. No. 661-451.100-940.000.]

**This Matter was ADOPTED BY THE MASTER RESOLUTION on the Consent Agenda.**

**210198.1** Amendment/Encouragement/Residents & Businesses/Become Vehicle City Blight Busters

Amended resolution resolving that the Mayor and Flint City Council hereby encourages all residents and businesses to clean their property of trash and other debris at least once a week and as needed in between, and partner with the city as volunteer Vehicle City Blight Busters to make the city a great place for families to live and unwelcome for those who wish to bring blight into the city. [NOTE: Resolution amended to include "and Flint City Council" with "By the Mayor."]

**SEPARATED FROM MASTER RESOLUTION**

## ADD-ON RESOLUTIONS

**210201** Approval/Installation/Ground-Mounted Sign/Central Park Neighborhood

Resolution resolving that the appropriate city officials are hereby authorized to do all things necessary to approve the placement of the ground-mounted sign for Central Park Neighborhood in the ROW at East Court and Northbound Chavez (PID 41-18-205-014), as requested by Zoning. [NOTE: Court Street Village Non-Profit has contracted for the installation of a ground-mounted sign to be installed at the Northeast corner of Court and Northbound Chavez on City ROW property. Flint City Council must authorize the placement of signs over public property, in accordance with City Code, Chapter 50-149.9 (c).]

**This Matter was ADOPTED BY THE MASTER RESOLUTION on the Consent Agenda.**

**210202** CO#1/Contract/Extend Contract/Rowe Professional Services Co./Comprehensive Zoning Services

Resolution resolving that city officials, upon City Council's approval, are authorized to do all things necessary to extend the contract [change order #1] with Rowe Professional Services Co. until October 31, 2021, and add \$60,000.00 to continue their provision of comprehensive zoning services with funds in the amount of \$60,000.00, to be made available from Planning & Development Medical Marijuana



Compliance Professional Services Acct. No. 101-371.220-801.000.

**A motion was made by Councilperson Galloway, seconded by Councilperson Guerra, that this matter be REFERRED TO COMMITTEE to the FINANCE COMMITTEE, due back on May 5, 2021. The motion carried by the following vote:**

**Aye:** 7 - Councilperson Mays, Councilperson Fields, Councilperson Winfrey-Carter, Councilperson Winfrey, Councilperson Galloway, Councilperson Griggs and Councilperson Worthing

**No:** 2 - Councilperson Davis and Councilperson Guerra

210203

Sale of City-Owned Land/3420 St. John Street/Evergrow, LLC

Resolution resolving that the appropriate city officials are authorized to do all things necessary to enter into and complete the sale of the property commonly known as 3420 St. John Street, Flint, MI, 48505, Parcel ID 47-31-487-015, and legally described as LOTS 425 THRU 443 AS ORIGINALLY PLATTED; LOT 444 EXC ELY 10 FT OF NLY 75 FT; LOT 445 EXC NLY 75 FT, GENERAL MOTORS PARK; ALSO A CONTIG UNPLATTED PARCEL OF LAND DESC AS FOLLS: THAT PART OF N8 RDS OF 1/2 OF NE 1/4 OF SEC 6, T7N, R7E LYING WLY OF WLY R.O.W. LINE OF JAMES P. COLE BLVD AS DESCRIBED IN DEED LIBER 2183, PAGES 869-873, GENESEE COUNTY RECORDS. EXC THAT PART OF VACATED ST JOHN ST. for a total cost of \$500,000.00 and transfer the property to Evergrow, LLC, in an AS IS condition, according to the terms agreed upon in the Purchase Agreement by means of conveyance of a Warranty Deed. Revenue realized from the sale of this real property will be placed in Revenue Acct. No. 101-371.209-673.100, AND, resolving that the City Clerk shall, within thirty (30) days of this action, record a certified copy of this resolution with the Register of Deeds for Genesee County and forward a certified copy of said resolution to the State Treasurer.

**A motion was made by Councilperson Galloway, seconded by Councilperson Guerra, that this matter be REFERRED TO COMMITTEE to the FINANCE COMMITTEE, due back on May 5, 2021. The motion carried by the following vote:**

**Aye:** 7 - Councilperson Mays, Councilperson Fields, Councilperson Winfrey-Carter, Councilperson Winfrey, Councilperson Galloway, Councilperson Griggs and Councilperson Worthing

**No:** 2 - Councilperson Davis and Councilperson Guerra

### **Passed The Consent Agenda**

**A motion was made by Councilperson Mays, seconded by Councilperson Winfrey, including all the preceding items marked as having been adopted on a Consent Agenda. The motion carried by the following vote:**

**Aye:** 9 - Councilperson Mays, Councilperson Davis, Councilperson Guerra, Councilperson Fields, Councilperson Winfrey-Carter, Councilperson Winfrey, Councilperson Galloway, Councilperson Griggs and Councilperson Worthing

## **SEPARATED FROM THE MASTER RESOLUTION**

**210176** Budget Amendment/Transfer of Funds/General Fund/City Clerk's Office/Elections

Resolution resolving that the appropriate city officials, upon City Council's approval, are hereby authorized to do all things necessary to incorporate the approved appropriation changes [totaling \$169,556.28] into the FY2020-FY2021 operating budget of the City of Flint [Election Wages Acct. No. 101-262.110-702.000 = \$45,000.00; Election Wages Acct. No. 101-262.100-702.000 = \$16,489.15; Election Transportation Acct. No. 101-262.100-860.000 = \$5,000.00; Election Rentals Acct. No. 101-262.100-940.000 = \$6,105.00; Election Temp Workers Acct. No. 101-262.110-707.000 = \$27,982.26; Election Overtime Acct. No. 101-262.100-713.000 = \$14,000.00; Election Overtime Acct. No. 101-262.110-713.000 = \$41,979.87; and Election Postage Acct. No. 101-262.100-902.000 = \$13,000.00.] [NOTE: The City Clerk would like to add funds to the line items provided to cover the costs of the May 2021 election. The Clerk also needs additional budget related to the increased costs of the November 2020 election due to the pandemic.]

**A motion was made by Councilperson Mays, seconded by Councilperson Winfrey, that this matter be Adopted. The motion carried by the following vote:**

**Aye:** 9 - Councilperson Mays, Councilperson Davis, Councilperson Guerra, Councilperson Fields, Councilperson Winfrey-Carter, Councilperson Winfrey, Councilperson Galloway, Councilperson Griggs and Councilperson Worthing

**210177** Maintenance/Easement/City of Flint Use/North Dort Highway Property/Secondary Water Source

Resolution resolving that the Flint City Council approves retaining a permanent easement on the North Dort Highway property at Frances Road for city use, including, but not limited to, Flint's Secondary Water Source, and the easement will be forever attached to the property.

**A motion was made by Councilperson Mays, seconded by Councilperson Davis, that this matter be Adopted. The motion carried by the following vote:**

**Aye:** 6 - Councilperson Davis, Councilperson Guerra, Councilperson Fields, Councilperson Winfrey, Councilperson Griggs and Councilperson Worthing

**No:** 2 - Councilperson Winfrey-Carter and Councilperson Galloway

**Abstain:** 1 - Councilperson Mays

**210198.1** Amendment/Encouragement/Residents & Businesses/Become Vehicle City Blight Busters

Amended resolution resolving that the Mayor and Flint City Council hereby encourages all residents and businesses to clean their property of trash and other debris at least once a week and as needed in between, and partner with the city as volunteer Vehicle City Blight Busters to make the city a great place for families to

live and unwelcome for those who wish to bring blight into the city. [NOTE: Resolution amended to include "and Flint City Council" with "By the Mayor."]

**A motion was made by Councilperson Davis, seconded by Councilperson Guerra, that this matter be Adopted. The motion carried by the following vote:**

**Aye:** 9 - Councilperson Mays, Councilperson Davis, Councilperson Guerra, Councilperson Fields, Councilperson Winfrey-Carter, Councilperson Winfrey, Councilperson Galloway, Councilperson Griggs and Councilperson Worthing

## RECONSIDERATION (of Appointments)

210173 Appointment/Ethics and Accountability Board/Page Brousseau IV

Resolution resolving that 9th Ward Flint City Councilperson Eva L. Worthing hereby appoints Page Brousseau IV (429 Burroughs Avenue, Flint, Michigan, 48507) to the Ethics and Accountability Board for the remainder of a six-year term of office, commencing immediately, and expiring June 25, 2024. [NOTE: By way of background, Joseph Pettigrew resigned from his position on the EAB Board in February 2021.]

**A motion was made by Councilperson Davis, seconded by Councilperson Griggs, that this matter be RECONSIDERED. The motion carried by the following vote:**

**Aye:** 7 - Councilperson Davis, Councilperson Guerra, Councilperson Fields, Councilperson Winfrey, Councilperson Galloway, Councilperson Griggs and Councilperson Worthing

**No:** 1 - Councilperson Winfrey-Carter

**Abstain:** 1 - Councilperson Mays

## APPOINTMENTS

210173 Appointment/Ethics and Accountability Board/Page Brousseau IV

Resolution resolving that 9th Ward Flint City Councilperson Eva L. Worthing hereby appoints Page Brousseau IV (429 Burroughs Avenue, Flint, Michigan, 48507) to the Ethics and Accountability Board for the remainder of a six-year term of office, commencing immediately, and expiring June 25, 2024. [NOTE: By way of background, Joseph Pettigrew resigned from his position on the EAB Board in February 2021.]

**A motion was made by Councilperson Mays, seconded by Councilperson Winfrey-Carter, that this matter be POSTPONED for May 10, 2021. The motion failed by the following vote:**

**Aye:** 4 - Councilperson Mays, Councilperson Winfrey-Carter, Councilperson Winfrey and Councilperson Galloway

**No:** 5 - Councilperson Davis, Councilperson Guerra, Councilperson Fields, Councilperson Griggs and Councilperson Worthing

A motion was made by Councilperson Davis, seconded by Councilperson Worthing, that this matter be Approved. The motion carried by the following vote:

**Aye:** 6 - Councilperson Davis, Councilperson Guerra, Councilperson Fields, Councilperson Winfrey, Councilperson Griggs and Councilperson Worthing

**No:** 3 - Councilperson Mays, Councilperson Winfrey-Carter and Councilperson Galloway

## APPOINTMENTS (May be Referred from Special Affairs)

210154 Appointment/Water System Advisory Council/Sheryl Thompson

Resolution resolving that Mayor Neeley hereby appoints Sheryl Thompson (4709 Crestbrook Lane, Flint, MI 48507) to serve on the Water System Advisory Council. [NOTE: Pursuant to the State of Michigan's administrative rules, water suppliers serving a population of 50,000 or more, shall create a Water System Advisory Council. The purpose of the Council is to improve transparency in the City of Flint community by developing materials and advising the water system on public awareness and education efforts.]

A motion was made by Councilperson Mays, seconded by Councilperson Galloway, that this matter be Approved. The motion carried by the following vote:

**Aye:** 8 - Councilperson Mays, Councilperson Davis, Councilperson Guerra, Councilperson Fields, Councilperson Winfrey-Carter, Councilperson Winfrey, Councilperson Galloway and Councilperson Worthing

**No:** 1 - Councilperson Griggs

210155 Appointment/Water System Advisory Council/James Gaskin

Resolution resolving that Mayor Neeley hereby appoints James Gaskin (41225 Lori Lane, Fenton, MI 48430) to serve on the Water System Advisory Council. [NOTE: Pursuant to the State of Michigan's administrative rules, water suppliers serving a population of 50,000 or more, shall create a Water System Advisory Council. The purpose of the Council is to improve transparency in the City of Flint community by developing materials and advising the water system on public awareness and education efforts.]

A motion was made by Councilperson Mays, seconded by Councilperson Winfrey-Carter, that this matter be POSTPONED for May 10, 2021. The motion carried by the following vote:

**Aye:** 5 - Councilperson Mays, Councilperson Winfrey-Carter, Councilperson Winfrey, Councilperson Galloway and Councilperson Griggs

**No:** 4 - Councilperson Davis, Councilperson Guerra, Councilperson Fields and Councilperson Worthing

## ROLL CALL

*Councilpersons Guerra and Fields left at 11:36 p.m.*

**Present:** Councilperson: Councilperson Mays, Councilperson Davis, Councilperson Winfrey-Carter, Winfrey, Councilperson Galloway, Councilperson Griggs and Councilperson Worthing

**Absent:** Councilperson: Councilperson Guerra and Councilperson Fields

## APPOINTMENTS CONTINUED

210156 Appointment/Water System Advisory Council/Earnestine Yvonne Lewis

Resolution resolving that Mayor Neeley hereby appoints Earnestine Yvonne Lewis (2171 South Linden Road, Flint, MI 48532) to serve on the Water System Advisory Council. [NOTE: Pursuant to the State of Michigan's administrative rules, water suppliers serving a population of 50,000 or more, shall create a Water System Advisory Council. The purpose of the Council is to improve transparency in the City of Flint community by developing materials and advising the water system on public awareness and education efforts.]

**A motion was made by Councilperson Mays, seconded by Councilperson Galloway, that this matter be Amended. The motion carried by the following vote:**

**Aye:** 7 - Councilperson Mays, Councilperson Davis, Councilperson Winfrey-Carter, Councilperson Winfrey, Councilperson Galloway, Councilperson Griggs and Councilperson Worthing

**Absent:** 2 - Councilperson Guerra and Councilperson Fields

210156.1 Amendment/Appointment/Water System Advisory Council/Earnestine Yvonne Lewis

Amended Resolution resolving that Mayor Neeley hereby appoints Earnestine Yvonne Lewis (806 Fisk Drive, Flint, MI 48503) to serve on the Water System Advisory Council. [NOTE: Pursuant to the State of Michigan's administrative rules, water suppliers serving a population of 50,000 or more, shall create a Water System Advisory Council. The purpose of the Council is to improve transparency in the City of Flint community by developing materials and advising the water system on public awareness and education efforts.] [NOTE: Resolution was amended to change Ms. Lewis' address to a local Flint address.]

**A motion was made by Councilperson Mays, seconded by Councilperson Winfrey-Carter, that this matter be Approved. The motion carried by the following vote:**

**Aye:** 6 - Councilperson Mays, Councilperson Davis, Councilperson Winfrey-Carter, Councilperson Winfrey, Councilperson Galloway and Councilperson Worthing

**No:** 1 - Councilperson Griggs

**Absent:** 2 - Councilperson Guerra and Councilperson Fields

## MOTION

*Councilperson Mays, with support from Councilperson Galloway, made a motion to postpone Resolution No. 210157 and the rest of the agenda to the next City Council meeting on May 10, 2021. The vote was 5:2 (No: Griggs, Worthing).*

**210157** Appointment/Water System Advisory Council/Nancy Love

Resolution resolving that Mayor Neeley hereby appoints Nancy Love (1351 Beal Avenue, Ann Arbor, MI 48109) to serve on the Water System Advisory Council. [NOTE: Pursuant to the State of Michigan's administrative rules, water suppliers serving a population of 50,000 or more, shall create a Water System Advisory Council. The purpose of the Council is to improve transparency in the City of Flint community by developing materials and advising the water system on public awareness and education efforts.]

**A motion was made by Councilperson Mays, seconded by Councilperson Galloway, that this matter be POSTPONED for May 10, 2021. The motion carried by the following vote:**

**Aye:** 5 - Councilperson Mays, Councilperson Davis, Councilperson Winfrey-Carter, Councilperson Winfrey and Councilperson Galloway

**No:** 2 - Councilperson Griggs and Councilperson Worthing

**Absent:** 2 - Councilperson Guerra and Councilperson Fields

## **SPECIAL ORDERS**

*All Special Orders were postponed to the next City Council meeting on May 10, 2021.*

**210218** Special Order/Republic Services/Composting & Trash

A Special Order as requested by Councilperson Monica Galloway to discuss composting and trash with Republic Services.

**210181** Special Order/Plaque for COVID-19 Victims

A Special Order as requested by Council President Fields to discuss having the City Council pay for a plaque to honor employees who have died of COVID-19.

**210172** Special Order/Discussion/Finance Committee Vice Chair

A Special Order as requested by Councilperson Worthing to discuss the Finance Committee Vice Chair.

**210171** Special Order/Special Meeting/\$99 Million/COVID-19 Relief Funds

A Special Order as requested by Councilperson Mays to discuss having a special meeting to talk about the \$99 million in COVID-19 relief funds.

**210167** Special Order/Special Orders

A Special Order as requested by Council President Fields to discuss Special

Orders.

**210124** Special Order/Bone Scans & Lead Measurement/Dr. Lawrence Reynolds

A Special Order as requested by Council President Fields to allow Dr. Lawrence Reynolds to present his findings on bone scanning equipment and their use in measuring lead exposure.

**210070** Special Order/Hatch Act

A Special Order as requested by Council President Fields to discuss the Hatch Act of 1939, which prohibits some forms of political activity.

## **ADJOURNMENT**

*Vice President Maurice Davis adjourned this meeting at 12:02 a.m. after a motion by Councilperson Galloway, with support from Councilperson Winfrey-Carter. The motion passed 6-0 (Absent: Guerra, Fields, Worthing).*

*Respectfully transcribed & submitted,*

*Janell Johnson, Administrative Secretary to City Council*

RESOLUTION: 210273

PRESENTED: JUN = 6 2021

ADOPTED:

**RESOLUTION OF APPOINTMENT  
TO THE ETHICS & ACCOUNTABILITY BOARD**

**BY THE CITY COUNCIL:**

Nicholas D'Aigle resigned his position on the Ethics & Accountability Board in December 2020; and

4<sup>th</sup> Ward Councilwoman Kate Fields recommends the appointment of Edna N. Sabucco (1426 Maplewood Avenue, Flint, MI 48506) to fill Mr. D'Aigle's unexpired term.

**THEREFORE, BE IT RESOLVED** that the Flint City Council approves the appointment of Edna N. Sabucco to serve Mr. D'Aigle's remaining six-year term on the Ethics and Accountability Board, commencing immediately, and expiring June 26, 2026.

**APPROVED AS TO FORM:**

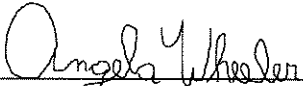
  
\_\_\_\_\_  
Angela Wheeler, Chief Legal Officer

**APPROVED BY FLINT CITY COUNCIL:**

\_\_\_\_\_  
Kate Fields, City Council President



**Edna N. Sabucco**  
**1426 Maplewood Ave. Flint MI 48506-3753**  
**(810) 908-7654**  
**edna.sabucco@att.net**

Dear Sir or Madam:

Please accept this letter and my resume as an expressed interest in a position on the Ethics and Accountability Board. For the past few years I have been serving the community by serving on the Citizens Advisory Committee for the Genesee County Land Bank, working with various entities throughout the city, i.e. Neighborhood Engagement Hub, Ruth Mott Foundation, Community Foundation of Greater Flint, many other neighborhood groups, and have served as the president as the Eastside Franklin Park neighborhood association.

I am interested in whatever is necessary to make Flint a better community for everyone and would like an opportunity to make a difference by serving on the board. Additional experience in customer service, call centers, medical billing and claims, health care delivery, and technology focused businesses, as well as raising a family, allow me the ability to appreciate and relate to all types of people. I have a strong sense of dedication and a desire to be productive in Flint as feelings of civic obligation run deep within me.

I look forward to an opportunity to discuss possible employment with your organization and hope to speak with you soon. Thank you for your time and consideration.

Sincerely,  
Edna N. Sabucco

**Edna N. Sabucco**  
**1426 Maplewood Ave. Flint MI 48506-3753**  
**(810) 908-7654**  
**edna.sabucco@att.net**

### **Career Objective**

**To obtain a position that allows growth potential, for the utilization and further development of my experience and skills.**

### **Employment History**

3/2011 – 5/2012                      Memorial Healthcare                      Owosso, MI

Health Unit Coordinator/Patient Registration Clerk

- Entering physician orders, scheduling Lab, Rad, and other procedures / disciplines
- Registration of patients for in-patient, out-patient, and emergency services
- Updating patient demographics and verification of services to be rendered
- Coding for services rendered, verification of insurances and coverage
- Operation of switchboard for hospital and satellite offices

4/2010-8/2010                      United States Census Bureau                      Flint, MI

Crew Leader (temporary position)

- Train enumerators for field work and assess job performance
- Distribute, collect, and assess questionnaires for quality and correctness
- Daily collection of payroll for assessment and processing
- Daily and weekly meetings with enumerators assist with any problems in the field

3/2006 – 8/2008                      Tender Loving Care/Amedisys                      Flint, MI

Field Services Coordinator

- Processing payroll for staff and management
- Liaison for staff, clients, and other facilities
- Coordination and scheduling of all staffing needs
- Maintaining proper documentation of services

1/2001 – 3/2006                      E.D.S./Convergys, Inc., G.M. OnStar                      Troy, MI

Reacquisition Advisor

- Facilitate and correct account discrepancies for subscriber retention
- Selling OnStar services to new and original subscribers with closed accounts
- Assist GM dealers in enrolling and activating services for new vehicle owners
- Directly involved with training and mentoring new employees to the department
- Participated in focus groups, with GM Engineers, to improve products

### **Education**

- Mott Community College
- Certificate of Achievement, Health Unit Coordinator Program 2010
- Associate Degree in Arts, Honors Graduate 2010
- Health Science Major, Certificate of Achievement Dental Assisting 1993
- Associate Degree in Applied Science, Honors Graduate 1993
- BLS Certified

**Edna N. Sabucco**  
**1426 Maplewood Ave. Flint MI 48506-3753**  
**(810) 908-7654**  
**edna.sabucco@att.net**

### **References**

Mark Berdan, Executive Director (Ret.)  
(Michigan Works, Region 7-B)  
402 N. First Street  
Harrison, MI 48625  
Res. (989) 685-8363  
Cell (989) 685-0161

Lisa Squier  
Psych. Instructor, MCC  
1301 Maplewood Ave.  
Flint, MI 48506  
Cell (810) 292-2655

Marta Whysall  
1717 Ohio Avenue  
Flint, MI 48506  
Cell (810) 513-5323

Kate Fields  
4th Ward Council Person  
2501 Maryland Ave.  
Flint MI 48506  
(810) 766-7418 x 3164

Jaime Martin-Wenzlick, MSW  
10163 Deerpath, S.  
Traverse City, MI 49685  
Cell (989) 284-7993

Cherie Palmer, RN, BSN  
(Heartland Health Care)  
309 Blanchard Avenue  
Flint, MI 48503  
Res. (810) 620-3241

Sandra Sprague, RN, BSN  
2954 N. 45th Road  
Manton, MI 49663  
Cell (231) 884-6066

Ashley Everhart, Director  
Neighborhood Engagement Hub  
3216 ML King Ave.  
Flint MI 48505  
(810) 620-1299 x 2

210274

RESOLUTION NO.: \_\_\_\_\_

PRESENTED: JUN - 6 2021

ADOPTED: \_\_\_\_\_

**RESOLUTION RECOMMENDING THE RE-APPOINTMENT OF CHRIS FLORES TO THE HURLEY BOARD OF HOSPITAL MANAGERS**

**BY THE MAYOR:**

**WHEREAS**, Chris Flores' term of office on the Hurley Board of Hospital Managers expired on April 30, 2021, although he continues to serve; and

**WHEREAS**, Mayor Sheldon A. Neeley recommends the re-appointment of Chris Flores to complete the five-year term on the Hurley Board of Hospital Managers, with such term that commenced on April 30, 2021, and expires April 30, 2026.

**THEREFORE, BE IT RESOLVED** that the Flint City Council approves the re-appointment of Chris Flores (1502 Brookwood Dr., Flint, MI 48503) to continue serving the five-year term on the Hurley Board of Hospital Managers, with such term commencing immediately and expires April 30, 2026.

**APPROVED AS TO FORM:**

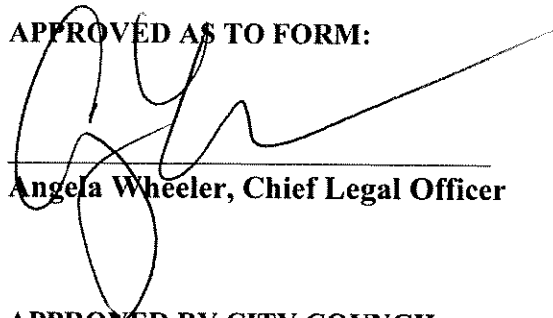
  
\_\_\_\_\_  
Angela Wheeler, Chief Legal Officer

**FOR THE CITY OF FLINT:**

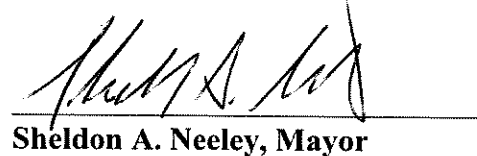
  
\_\_\_\_\_  
Sheldon A. Neeley, Mayor

**APPROVED BY CITY COUNCIL:**

\_\_\_\_\_  
Kate Fields, City Council President

## CHRISTOPHER J. FLORES

He is currently District Director for U.S. Congressman Dan Kildee Michigan 5<sup>th</sup> Congressional District. Mr. Flores is the former Vice President Healthcare Integration with the Sacred Heart Rehabilitation Center (SHRC) and Team Leader for Sacred Heart Outpatient and medication assisted programming in Flint Mi. SHRC is the State of Michigan largest substance abuse woman's specialty program. Mr. Flores has been very active in the health care field. Some of his accomplishments include the founding of Community Recovery Services Model for the Michigan Prisoner Re Entry Initiative, Co-Founder Hopeful Hearts a hospital based specialized opiate dependent pregnancy program. Executive Director of Insight Recovery Centers and Odyssey House Inc. Mr. Flores' education includes a Paralegal Certificate in 1977 from the Adelphi University in New York, NY, and past certifications and training in Substance Use Disorders in 1978. Mr. Flores has extensive training in Neonatal Abstinence Syndrome (NAS) Board governance, conflict mediation, labor relations, strategic planning, community health planning, coalition building and public speaking. Mr. Flores completed the Mich. Health and Hospital Association Excellence in Governance Fellowship in 2009.

In addition to his accomplishments, Mr. Flores is quite active in community affairs as well as at the State and Federal levels. Christopher J. Flores has been a member of the Hurley Medical Center Board of Managers since 1990 and current chair of quality. Former Board member of Health Plus of Michigan where he served as chair of Health Plus Partners Medicaid Plan. Greater Flint Chamber of Commerce strategic advisory member, Flint Institute of Arts Board Member, Current Food Bank of Eastern Michigan Board Member and Hurley Representative to the MSU School of Research, Current Greater Flint Health Coalition Board Member, and current Finance Committee Chair Court Street United Methodist. He has received several awards, including; Donald Riegle Community Service Award, the Genesee County Hispanic Leadership Award in 1997 & 2010, the Clayton Stroup Foundation Award in 1989, and the Distinguished Person of the Year – Michigan Association of Alcohol and Addiction in 1989. In 2008 he was appointed by the Governor of Michigan to serve on the Michigan State Board of Psychology (2008-2011).



RESOLUTION NO.:

210233.1

PRESENTED: \_\_\_\_\_

JUN 14 2021

ADOPTED: \_\_\_\_\_

**RESOLUTION APPROVING CITY OF FLINT BROWNFIELD REDEVELOPMENT  
AUTHORITY BROWNFIELD PLAN FOR THE JAMES P. COLE PROJECT**

(1809 James P. Cole)

**BY THE CITY ADMINISTRATOR:**

On July 28, 1997, the Flint City Council adopted a resolution establishing the Brownfield Redevelopment Authority (Authority) of the City of Flint pursuant to the Brownfield Redevelopment Financing Act 381 of the Public Acts ("Act") of 1996, to promote the revitalization, redevelopment and reuse of certain blighted, tax reverted and functionally obsolete properties.

Under Act 381, the Authority is authorized to develop and propose for adoption by the City Council a brownfield plan for one (1) or more parcels of eligible properties.

Pursuant to the resolution establishing the Authority and the bylaws of the Authority, the Authority has submitted a proposed brownfield plan for 1809 James P. Cole (the Plan).

The required notice of the public hearing on the proposed Plan was given in accordance with section 13 of Act 381, and such hearing held by the City Council on March 8, 2021.

Once approved, the brownfield plan will allow of the reimbursement of eligible project expenses from the additional tax revenue realized as a result of the redevelopment. The reimbursement can occur over the life of the plan which is normally 30 years. The eligible reimbursable expenses are estimated at around \$2,541,508.

**IT IS RESOLVED, THAT:**

1. Definitions. Where used in this Resolution, the terms set forth below shall have the following meaning unless the context clearly requires otherwise:

"Eligible Activities" or "eligible activity" shall have the meaning described in Act 381.

"Eligible Property" means the property designated in the Plan as the Eligible Property, as described in Act 381.

"Plan" means the Plan prepared by the Authority, as transmitted to the City Council by the Authority for approval, copies of which Plan are on file in the office of the City Clerk.

"Taxing Jurisdiction" shall mean each unit of government levying an ad valorem property tax on the Eligible Property.

2. Public Purpose. The City Council hereby determines that the Plan constitutes a public purpose.
3. Best Interest of the Public. The City Council hereby determines that it is in the best interest of the public to promote the revitalization of environmentally distressed areas in the City to proceed with the Plan.
4. Review Considerations. As required by act 381, including consideration of the criteria of "facility" as defined in act 381;
  - a. Portions of the property designated in the Plan meet the definition of Eligible Property, as described in act 381, including consideration of the criteria of "facility" as defined in Act 381;
  - b. The Plan meets the requirements set forth in section 13 of Act 381.

- c. The proposed method of financing the costs of eligible activities is feasible and the authority has the ability to arrange the financing.
  - d. The costs of eligible activities proposed are reasonable and necessary to carry out the purpose of Act 381.
  - e. The amount of captured taxable value estimated to result from adoption of the Plan is reasonable.
5. Approval and Adoption of Plan. The Plan as submitted by the authority is hereby approved and adopted. A copy of the Plan and all amendments thereto shall be maintained on file in the City Clerk's office.
  6. Establishment of Project Fund; Approval of Depository. The Authority shall establish a separate fund for the Eligible Property subject to this Plan, which shall be kept in a depository bank account or accounts in bank or banks approved by the Treasurer of the City. All monies received by the Authority pursuant to the Plan shall be deposited in the Project Fund for the Eligible Property. All monies in the Project Fund and earnings thereon shall be used only in accordance with the Plan and Act 381.
  7. Use of Monies in the project Fund. The monies credited to the Project Fund and on hand therein from time to time shall be used annually to first make those payments authorized by and in accordance with the Plan and any development.
  8. Payment of Tax Increment Revenues to Authority. The municipal and the county treasurers shall, as ad valorem and specific local taxes are collected on the Eligible Property, pay the Tax Increment Revenues to the Authority for deposit in the Project Fund. The payments shall be made not more than 20 days after the Tax Increment Revenues are collected.
  9. Disclaimer. By adoption of this Resolution and approval of the Plan, the City assumes no obligation or liability to the owner, developer, lessee or lessor of the eligible property for any loss or damage that may result to such persons from the adoption of this Resolution and Plan. The City makes no guarantees or representation as to the determinations of the appropriate state officials regarding the ability of the Authority to capture tax increment revenues from the state and local school district taxes for the Plan.
  10. Repealer. All of this resolution and parts of resolutions insofar as they conflict with the provisions of this resolution shall be rescinded.

Approved as to Form:

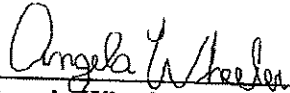
  
 \_\_\_\_\_  
 Angela Wheeler  
 Chief Legal Officer

ADMINISTRATION:

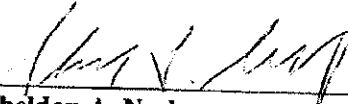
  
 \_\_\_\_\_  
 Sheldon A. Neeley  
 Mayor

\_\_\_\_\_  
 Kate Fields, Council President



CITY OF FLINT

RESOLUTION STAFF REVIEW FORM

TODAY'S DATE: 2/3/2021

BID/PROPOSAL#

AGENDA ITEM TITLE: Brownfield Plan Approval

PREPARED BY Khalfani Stephens
(Please type name and Department)

VENDOR NAME:

BACKGROUND/SUMMARY OF PROPOSED ACTION:

This is a resolution to establish a brownfield plan for 1809 James P. Cole. The project is estimated to be approximately \$14.25 Million and will result in approximately 110K SF of renovated industrial space and 190K of new industrial space. New job creation is TBD.

FINANCIAL IMPLICATIONS: This will reduce the taxes collected for up to 30 years (see attached table)

BUDGETED EXPENDITURE? YES [ ] NO [X] IF NO, PLEASE EXPLAIN:

Table with 5 columns: Dept., Name of Account, Account Number, Grant Code, Amount. Includes a row for FY19/20 GRAND TOTAL.

PRE-ENCUMBERED? YES [ ] NO [ ] REQUISITION NO:





**CITY OF FLINT**

**ACCOUNTING APPROVAL:** \_\_\_\_\_ **Date:** \_\_\_\_\_

**WILL YOUR DEPARTMENT NEED A CONTRACT?** YES  NO   
*(If yes, please indicate how many years for the contract)* YEARS

**WHEN APPLICABLE, IF MORE THAN ONE (1) YEAR, PLEASE ESTIMATE TOTAL AMOUNT FOR EACH BUDGET YEAR: (This will depend on the term of the bid proposal)**

**BUDGET YEAR 1**

**BUDGET YEAR 2**

**BUDGET YEAR 3**

**OTHER IMPLICATIONS (i.e., collective bargaining):**

**STAFF RECOMMENDATION: (PLEASE SELECT):**  **APPROVED**  **NOT APPROVED**



**DEPARTMENT HEAD SIGNATURE:** \_\_Khalfani Stephens, Economic Development Director  
*(PLEASE TYPE NAME, TITLE)*

EXHIBIT A

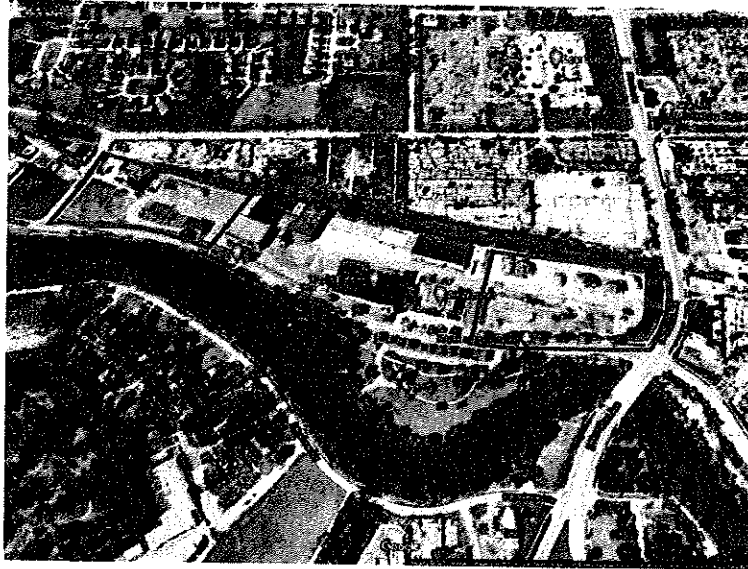
CITY OF FLINT  
BROWNFIELD REDEVELOPMENT AUTHORITY



BROWNFIELD PLAN FOR THE  
PROPOSED DUPONT INDUSTRIAL FACILITY  
REDEVELOPMENT PROJECT

Prepared for	Prepared By
 <p><b>DEARBORN CAPITAL</b> Capital Partners, LLC</p> <p>James P Cole Venture, LLC Attn: Ms. Mona Navitsky c/o Dearborn Capital Partners, LLC 980 North Michigan, Suite 1620 Chicago, IL 60611 Attn: Mr. Brien Wloch; Managing Member M (312) 543-1250 E <a href="mailto:mona.navitsky@dearcapcre.com">mona.navitsky@dearcapcre.com</a></p>	 <p>Mr. Nicholas G. Maloof, RPG President and General Counsel Associated Environmental Services, LLC 40701 Woodward Avenue, Suite 50 Bloomfield Hills, MI 48304 T (248) 203-9898 M (248) 250-2525 E <a href="mailto:ngm@associatedenvironmental.net">ngm@associatedenvironmental.net</a> W <a href="http://www.associatedenvironmental.net">www.associatedenvironmental.net</a></p>

Plan Preparation Date: **October 31, 2020**

Approved by the Brownfield Redevelopment Authority on: \_\_\_\_\_

Approved by the Flint City Council on: \_\_\_\_\_

**CITY OF FLINT  
BROWNFIELD REDEVELOPMENT AUTHORITY  
BROWNFIELD PLAN**

**TABLE OF CONTENTS**

I.	INTRODUCTION	I-4
II.	GENERAL PROVISIONS	
	A. Description of Eligible Property	II-5
	B. Basis of Eligibility	II-7
	C. Summary of Eligible Activities	II-9
	D. Estimate of Captured Taxable Value and Tax Increment Revenues; Impact of Tax Increment Financing on Taxing Jurisdictions	II-11
	E. Plan of Financing; Maximum Amount Of Indebtedness	II-13
	F. Duration of Plan	II-13
	G. Effective Date of Inclusion	II-14
	H. Displacement/Relocation of Individuals On Eligible Property	II-14
	I. Local Brownfield Revolving Fund (LBRF)	II-14
	J. Brownfield Redevelopment Fund	II-15
	K. Developer's Obligations, Representations and Warrants	II-15
III.	ATTACHMENTS	
	A. Site Map	A
	B. Legal Description(s)	B
	C. Project Description	C
	D. Supportive Letters	D

E. Estimated Cost of Eligible Activities	E
F. TIF Tables	F
G. BSE&E Acknowledgement and Other Environmental Documents	G

## **I. INTRODUCTION**

---

In order to promote the revitalization of environmentally distressed and blighted areas within the boundaries of the City of Flint, Michigan (the "City"), the City has established the City of Flint Brownfield Redevelopment Authority (the "FBRA") pursuant to Michigan Public Act 381 of 1996, as amended ("Act 381").

The primary purpose of this Brownfield Plan ("Plan") is to promote the redevelopment of and private investment in certain "brownfield" properties within the City. Inclusion of property within this Plan will facilitate financing of environmental response and other Eligible Activities at eligible properties, and will also provide tax incentives to eligible taxpayers willing to invest in revitalization of eligible sites, commonly referred to as "brownfields." By facilitating redevelopment of brownfield properties, this Plan is intended to promote economic growth for the benefit of the residents of the City and all taxing units located within and benefited by the FBRA.

This Plan is intended to apply to the eligible property identified in this Plan and, if tax increment revenues are proposed to be captured from that eligible property, to identify and authorize the Eligible Activities to be funded by such tax increment revenues.

This Plan is intended to be a living document, which may be modified or amended in accordance with the requirements of Act 381, as necessary to achieve the purposes of Act 381. The applicable sections of Act 381 are noted throughout the Plan for reference purposes.

This Plan describes the project to be completed (see Attachment C) and contains information required by Section 13(2) of Act 381.

## II. GENERAL PROVISIONS

### **A. Description of the Eligible Property (Section 13 (2)(h)) and the Project**

The property comprising the eligible property consists of multiple parcel of land that are either contaminated and qualify as a “facility” as that term is defined in Part 201 of NREPA, as amended, are immediately adjacent to the “facility” and/or will be unified with the “facility” parcel(s). **Each parcel is eligible as it is either contaminated and qualifies as a “facility” and/or it is adjacent to and being combined with a parcel that is a “facility.”**

The parcel and all tangible personal property located thereon will comprise the eligible property and is referred to herein as the “Property.”

**Attachment A** includes a site map of the Property. The Property is located east of Industrial Avenue, south of East Hamilton Avenue, west of James P. Cole Boulevard, and north of East Wood Street. The Property contains one several existing structures. The Property was historically used for industrial activities/purposes since the early 1900’s.

The existing structures and buildings have been mostly unoccupied for several years.

The eligible property will include all tangible personal property to be located on the real property. Parcel information is outlined below.

Address	1809 James P. Cole Boulevard, Flint, Genesee County, MI 48503
Parcel ID	Parcel ID Nos. 41-06-452--014 & 41-06-452-015
Owner	James P Cole Venture, LLC
Legal Description (obtained from ALTA Survey)	SEE ATTACHED ALTA Survey

James P Cole Venture, LLC is the project developer (“Developer”) and owner of the Property.

The proposed Project is comprised of a build-to-suit redevelopment of a 17.99 acre historically industrial property currently containing approximately 110,578 square feet of existing structures. According to information provided to AES, the Property is proposed to be redeveloped into a multi-tenant multi-building industrial park. According to a Site Plan provided by Developer, approximately 110,578 square feet of existing building will remain and undergo renovations with the remaining buildings being demolished to make way for an additional 190,700 square feet of proposed new construction buildings, all on 17.99 acres of improved commercial and industrial land.

The completed development will include two single or multiple tenant structures each of which can be expanded to accommodate growth of an existing tenant or additional tenants within the proposed structures.

The Project will be undergoing site plan and zoning review by the City of Flint Engineering Department and Planning & Development Departments, and is therefore subject to change as part of the approval processes. The Project is currently estimated to be an estimated \$14,250,000.00 (excluding land costs) investment by Developer plus any furniture, fixtures and equipment (FF&E) and other Personal Property of the proposed tenants (Operators).

It is currently anticipated, subject to necessary Planning, Engineering, FBRA and State of Michigan EGLE, MEDC/MSF, and Tax Commission approvals, that construction will begin in the Summer/Fall of 2021, or sooner, subject to approval of Eligible Activities, including retroactive approval of completed Eligible Activities. It is anticipated that the Eligible Activities will be completed within 12-18 months of the start date.

The project description provided herein is a summary of the proposed development at the time of the adoption of the Plan. The actual development may vary from the project description provided herein, without necessitating an amendment to this Plan, so long as such variations are not material and arise as a result of governmental processes, changes in market and/or financing conditions affecting the project and/or are related to the addition or immaterial removal of amenities to the project. All material changes, as determined by FBRA in its reasonable discretion, to the project description are subject to the approval of the FBRA staff and shall be consistent with the overall nature of the proposed development, its proposed public purpose, and the purposes of Act 381.

#### **Census Tract Qualification**

The Property is located in a low-income community (LIC) Census Tract (Census Tract No. 26049013600). A low-income community (LIC) Census Tract is defined as, "...a poverty rate of at least 20 percent or with median family incomes that do not exceed 80 percent of area median income..." In addition, the Property is located in a Qualified Opportunity Zone, which means that the area has been targeted by State and Local Governmental Units for development. *Please see the attached CDFI Fund Census Tract Map.*

Based on the information provided by Developer, the Property contains structures and infrastructure that will be demolished and/or partially demolished and removed as part of the planned re-development ("Project"). In addition, the proposed Project will redevelop an underutilized Property that contains multiple impediments to redevelopment. The proposed Project will create temporary construction jobs and is intended to create permanent jobs in an area of Genesee County (Flint) with a high unemployment rate as demonstrated by the Census Tract information.

**Attachment C** provides a description of the project to be completed at the Property (the "Project"). **Attachment C** also includes details regarding development team, total investment amount, description of project uses number of temporary and permanent jobs,

project renderings, and additional financing incentives (IFT). **Attachment D** includes letters of support for the Project.

**B. Basis of Eligibility (Section 13 (2)(h) and Section 2 (o))**

The Property qualifies as a “facility” as that term is defined under the natural Resources and Environmental Protection Act (NREPA), P.A.451 of 1994, as amended, based on the presence of soil contamination.

The Property is considered “eligible property” as defined by Act 381, Section 2 because (a) the Property was used for industrial purposes; (b) it is located within the City of Flint, a qualified local governmental unit under Act 381; and (c) the Property is determined to be a “facility” as defined by Act 381.

The Property qualifies as a “facility” and is eligible for Brownfield Redevelopment Incentives pursuant to the Brownfield Redevelopment Financing Act, P.A. 381 of 1996, as amended. The Property is classified as a “facility” due to the presence of soil contamination related to historical use and operation of portions of the Property for industrial purposes.

In addition, based on the condition of the existing structures, the Property could also qualify under either “blighted<sup>2</sup>” or “functionally obsolete<sup>3</sup>” status, however, Developer has not moved forward with either or both such designations as the Property already qualifies under Act 381.

**Phase I Environmental Site Assessment (ESA)**

Applied Ecosystems, Inc. (AEI) was retained by Developer to prepare a Baseline Environmental Assessment (BEA) and published the BEA on September 20, 2016 as of pre-acquisition due diligence and disclosed to MDEQ on December 7, 2016.

According to information presented the BEA, the Property was historically used for industrial activities/purposes by E. I. du Pont de Nemours and Company (DuPont) and predecessor companies since the early 1900’s beginning in 1901 with Flint varnish and Color Works providing paint and varnishes for the carriage industry and converting to automotive paint manufacturing in 1910. DuPont purchased the property in 1918 and operated on-site until 1995. In 1989, DuPont initiating environmental site investigation activities to assess soil and groundwater on the Property.

In 2003 DuPont entered into a Voluntary Corrective Action agreement with MDEQ and actions included:

- Excavation and disposal of contaminated soil;
- Groundwater treatment; and
- Free product removal.

In 2005, a Remedial Action Plan (RAP) was prepared that specified long term groundwater treatment as well as property use restrictions (Deed Restrictions).



In 2015, after 12 consecutive monthly gauging events with no free product present, DuPont submitted a request for a “No Further Action” determination related to free product removal activities

Contamination remaining on-site includes volatile organic compounds (VOCs), semi-VOCs (SVOCs), arsenic, chromium, cobalt and cyanide. Known impacted media include soil and groundwater with exceedances of the volatilization to indoor air (VIA) pathway likely based on the known concentrations of VOCs.

*Please see Figures 1 and 2 for Site Location and Aerial Photo Maps.*

Based on the documented concentrations of soil and groundwater contamination, concentrations exceed the EGLE Part 201 Generic Residential Cleanup Criteria (GRCC) promulgated under Part 201 of the Natural Resources and Environmental Protection Act (NREPA), 1994 P.A. 451, as amended (Part 201), and therefore the Property meets the definition of a “facility” as defined pursuant to Part 201.

As the Property qualifies as a “facility<sup>1</sup>,” it is eligible for Brownfield Redevelopment Incentives pursuant to the Brownfield Redevelopment Financing Act, P.A. 381 of 1996, as amended. In addition, based on the condition of the existing structures, the Property could also qualify under either “blighted<sup>2</sup>” or “functionally obsolete<sup>3</sup>” status.

Sample results were compared to current Generic Residential Cleanup Criteria (GRCC) promulgated under Part 201 of the Natural Resources and Environmental Protection Act (NREPA), 1994 P.A. 451, as amended (Part 201). Based on the results of the Phase II ESA the Property meets the definition of a “facility” as defined pursuant to Part 201.

<sup>1</sup>Under Part 201 of NREPA, P.A. 451 of 1994, as amended, Section 20101(1)(s) states

“Facility” means any area, place, parcel or parcels of property, or portion of a parcel of property where a hazardous substance in excess of the concentrations that satisfy the cleanup criteria for unrestricted residential use has been released, deposited, disposed of, or otherwise comes to be located. Facility does not include any area, place, parcel or parcels of property, or portion of a parcel of property where any of the following conditions are satisfied:

- (i) Response activities have been completed under this part or the comprehensive environmental response, compensation, and liability act, 42 USC 6601 to 9675, that satisfy the cleanup criteria for unrestricted residential use.
- (ii) Corrective action has been completed under the resource conservation and recovery act, 42 USC 6901 to 6992k, part 111, or part 213 that satisfies the cleanup criteria for unrestricted residential use.
- (iii) Site-specific criteria that have been approved by the department for application at the area, place, parcel of property, or portion of a parcel of property are met or satisfied and hazardous substances at the area, place, or property that are not addressed by site-specific criteria satisfy the cleanup criteria for unrestricted residential use.
- (iv) Hazardous substances in concentrations above unrestricted residential cleanup criteria are present due only to the placement, storage, or use of beneficial use by-products or inert materials at the area, place, or property in compliance with part 115.
- (v) The property has been lawfully split, subdivided, or divided from a facility and does not contain hazardous substances in excess of concentrations that satisfy the cleanup criteria for unrestricted residential use.
- (vi) Natural attenuation or other natural processes have reduced concentrations of hazardous substances to levels at or below the cleanup criteria for unrestricted residential use.

SEE: <http://www.legislature.mi.gov/S11xfrucvmyh4dlqaeqzmk31/mleg.aspx?page=getObject&objectName=mcl-324-20101>

<sup>2</sup>Under MCL 125.2652(2)(e) “Blighted” means property that meets any of the following criteria as determined by the governing body

- (i) Has been declared a public nuisance in accordance with a local housing, building, plumbing, fire, or other related code or ordinance.
- (ii) Is an attractive nuisance to children because of physical condition, use, or occupancy.
- (iii) Is a fire hazard or is otherwise dangerous to the safety of persons or property.
- (iv) Has had the utilities, plumbing, heating, or sewerage permanently disconnected, destroyed, removed, or rendered ineffective so that the property is unfit for its intended use.
- (v) Is tax reverted property owned by a qualified local governmental unit, by a county, or by this state. The sale, lease, or transfer of tax reverted property by a qualified local governmental unit, county, or this state after the property’s inclusion in a brownfield plan shall not result in the loss to the property of the status as blighted property for purposes of this act.
- (vi) Is property owned or under the control of a land bank fast track authority, whether or not located within a qualified local governmental unit. Property included within a brownfield plan prior to the date it meets the requirements of this subdivision to be eligible property shall be considered to become eligible property as of the date the property is determined to have been or becomes qualified as, or is combined with, other eligible property. The sale, lease, or transfer of the property by a land bank fast track authority after the property’s inclusion in a brownfield plan shall not result in the loss to the property of the status as blighted property for purposes of this act.
- (vii) Has substantial subsurface demolition debris buried on site so that the property is unfit for its intended use.

<sup>1</sup>Under MCL 125.2652(2)(s) "Functionally obsolete" means that the property is unable to be used to adequately perform the function for which it was intended due to a substantial loss in value resulting from factors such as overcapacity, changes in technology, deficiencies or superadequacies in design, or other similar factors that affect the property itself or the property's relationship with other surrounding property.

**C. Summary of Eligible Activities and Description of Costs (Section 13 (2)(a),(b))**

The "Eligible Activities" that are intended to be carried out at the Property are considered "Eligible Activities" as defined by Sec 2 of Act 381, because they include, but are not limited to: (1) Phase I ESA, Phase II ESA and Baseline Environmental Assessment activities; (2) 7a Due Care Activities including Phase II ESA Due Care Investigation Activities and Preparation of pre-development and post-development Due Care Plans or Documentation of Due Care Compliance; (3) Additional Response Activities; (4) Building Demolition Activities including selective exterior and interior demolition and lead, asbestos and hazardous materials abatement; (5) Development and Preparation of Brownfield Plan and Act 381 Work Plan; (6) UST Removal Activities; (7) Remediation Activities including installation of engineering controls and operation & maintenance (O&M) related to the engineering controls; (8) Site Preparation Activities to ready the site for redevelopment including utility disconnection and re-connection, removal and re-location of public utilities, land balancing and rough and finished grading; (9) Infrastructure Activities including the construction of storm water retention/detention ponds and/or systems, and installation of new utilities; and (10) Public Improvements including installation of public utilities, street improvements, deceleration lanes and drive approaches, streetscapes, landscaping and other related activities. In addition, supplementary Eligible Activities that are financial in nature include: (1) Interest on the sums expended to implement the Eligible Activities at a rate of five (5%) per annum; and (2) environmental insurance may be obtained at some during the project development process.

A summary of the Eligible Activities and the estimated cost of each eligible activity intended to be paid for with Tax Increment Revenues from the Property are shown in the table attached hereto as **Attachment E**.

The Eligible Activities described in **Attachment E** are not exhaustive. Subject to the approval of FBRA staff in writing, additional Eligible Activities may be carried out at the Property, without requiring an amendment to this Plan, so long as such Eligible Activities are permitted by Act 381 and the performance of such Eligible Activities does not exceed the total costs stated in **Attachment E**.

Unless otherwise agreed to in writing by the FBRA, all Eligible Activities shall commence within eighteen (18) months after the date the governing body approves this Plan and be completed within three (3) years after approval of the Michigan Strategic Fund work plan, if applicable, or three (3) years after execution of the Reimbursement Agreement (as that term is defined below). Any long-term monitoring or operation and maintenance activities or obligations that may be required will be performed in compliance with the terms of this Plan and any documents prepared pursuant to this Plan.

The Developer desires to be reimbursed for the costs of Eligible Activities. Tax increment revenue generated by the Property will be captured by the FBRA and used to reimburse

the cost of the Eligible Activities completed on the Property pursuant to the terms of a Reimbursement Agreement to be executed by the FBRA and the Developer after approval of this Plan (the "Reimbursement Agreement"), to the extent permitted by Act 381. In the event this Plan contemplates the capture of tax increment revenue derived from "taxes levied for school operating purposes" (as defined by Section 2(oo) of Act 381 and hereinafter referred to as "School Taxes"), the Developer acknowledges and agrees that FBRA's obligation to reimburse the Developer for the cost of Eligible Activities with tax increment revenue derived from School Taxes, or Specific Taxes that are considered School Taxes, (as these capitalized terms are defined by Act 381) is contingent upon the Developer receiving at least the initial applicable work plan approvals by the Michigan Strategic Fund and/or the EGLE, as may be required pursuant to Act 381.

**FBRA agrees to retroactively reimburse Developer for all Eligible Activities completed prior to the approval of this Plan and for Eligible Activities completed as described in this Plan from the Local Taxes, or Specific Taxes that are considered Local Taxes, at the percentage ratio that Local Taxes comprise the overall combined Local and School Taxes. To the extent that Developer obtains Act 381 Work Plan approval from EGLE or MEDC/MSF, then the remaining percentage of Eligible Activities will be reimbursed to Developer. If deemed necessary, Developer will provide the FBRA with evidence, reasonably satisfactory to FBRA, that the Developer has the financial means to complete the project without the capture of, and subsequent reimbursement with, the contemplated School Taxes.**

This Plan provides for the capture of taxes levied for school purposes (School Tax Capture), comprised of the State Education Tax (SET) and School Operating Tax, from the eligible Property. However, as the approval of School Tax Capture is at the discretion of the EGLE and MEDC/MSF, all Eligible Activities shall be reimbursable from Local Taxes unless School Tax Capture is approved by the agency responsible for the Eligible Activity(ies), then reimbursement will be from a combination of both Local and School Taxes.

The estimated costs outlined in this Plan and listed in **Attachment E** may increase or decrease depending on the nature and extent of any unknown or unanticipated conditions on the Property. As long as the total costs, adjusted by the 15% factor, are not exceeded, the line item costs of the Eligible Activities outlined herein, in the attachments and/or in the Brownfield Plan, may be adjusted between the Eligible Activities after the date this Plan is approved without the need for any additional approval from City of Flint City Council or the City of Flint Brownfield Redevelopment Authority, to the extent those adjustments do not violate the terms of any EGLE or MEDC/MSF approved work plan, if any. If necessary, this Plan may also be amended to add or delete Eligible Activities and the estimated cost of each.

The costs listed in **Attachment E** are estimated costs and may increase or decrease depending on the nature and extent of environmental contamination and other unknown conditions encountered on the Property. The actual cost of those Eligible Activities encompassed by this Plan that will qualify for reimbursement from tax increment revenues

of the FBRA from the Property shall be governed by the terms of the Reimbursement Agreement. No costs of Eligible Activities will be qualified for reimbursement except to the extent permitted in accordance with the terms and conditions of the Reimbursement Agreement and Section 2 of Act 381. The Reimbursement Agreement and this Plan will dictate the total cost of Eligible Activities subject to payment or reimbursement, provided that the total cost of Eligible Activities subject to payment or reimbursement under the Reimbursement Agreement shall not exceed the estimated costs set forth in **Attachment E**. As long as the total costs, adjusted by the 15% contingency under Act 381, are not exceeded, line item costs of Eligible Activities may be adjusted after the date this Plan is approved by the governing body (Flint City Council), to the extent the adjustments do not violate the terms of the approved EGLE or MSF work plan.

**D. Estimate of Captured Taxable Value and Tax Increment Revenues (Section 13(2)(c)); Beginning Date of Capture of Tax Increment Revenues (Section 13(2)(f)); Impact of Tax Increment Financing on Taxing Jurisdictions (Section 13(2)(g))**

This Plan anticipates the capture of tax increment revenues to reimburse the Developer for the costs of Eligible Activities under this Plan in accordance with the Reimbursement Agreement. A table of estimated tax increment revenues to be captured is attached to this Plan as **Attachment F**.

Tax increments are projected to be captured and applied to (i) reimbursement of eligible activity costs and payment of FBRA administrative and operating expenses, (ii) make deposits into the State Brownfield Redevelopment Fund, and (iii) make deposits into the FBRA's Local Brownfield Revolving Fund, as follows:

Exhibit A  
 PROPOSED DUPONT INDUSTRIAL FACILITY  
 Brownfield Redevelopment Plan

<b>Section D Capture Summary Table<sup>1</sup></b>			
	<b>Developer P&amp;I</b>	<b>Local RLF</b>	<b>State Brownfield RLF</b>
<b><u>School Capture</u></b>			
State Education Tax (SET)	\$222,116.24	\$81,770.29	\$303,887
School Operating Tax	\$1,428,867	\$490,622	
<b><u>Local Capture</u></b>			
County Operating	\$404,311	\$148,844	
Library	\$296,155	\$109,027	
Flint Operating	\$555,291	\$204,426	
Public Safety	\$444,232	\$163,541	
Misc. Levies	\$670,747	\$246,930	
Genesee County Parks	\$55,366	\$20,383	
Parks and Rec	\$37,019	\$13,628	
Genesee ISD	\$277,327	\$102,096	
Mass Transit	\$90,483	\$33,310	
Flint Sinking Fund	\$87,366	\$32,163	
CS Mott Operating	\$145,893	\$53,709	
<b>TOTAL</b>	<b>\$4,715,173</b>	<b>\$1,700,449</b>	<b>\$303,887</b>

In addition, the following taxes are projected to be generated but shall not be captured during the life of this Plan:		
<b><u>Non-Capturable Millages</u></b>		
Flint School Debt	\$208,789	\$76,864
CS Mott Debt	\$58,491	\$21,533
Public Library Debt	\$134,751	\$49,607
<b>TOTAL</b>	<b>\$402,030</b>	<b>\$148,004</b>

<sup>1</sup>All numbers presented are based on gross taxes generated in the Capture side of the TIR Capture Tables and may differ from the actual reimbursement amounts from each millage levy due to allocation percentages and rounding of numbers.

In no event shall the duration of this Plan exceed thirty-five (35) years following the date of the governing body's resolution approving this Plan, nor shall the duration of the tax capture exceed the lesser of the period authorized under subsection (3) and (5) of Section 13 of Act 381 or 30 years. Further, in no event shall the beginning date of the capture of tax increment revenues be later than five (5) years after the date of the governing body's resolution approving this Plan.

**E. Plan of Financing (Section 13(2)(d)); Maximum Amount of Indebtedness (Section 13(2)(e))**

The Eligible Activities are to be financed solely by the Developer. The FBRA will reimburse the Developer for the cost of approved Eligible Activities, but only from tax increment revenues generated from the Property. No advances have been or shall be made by the City or the FBRA for the costs of Eligible Activities under this Plan.

All reimbursements authorized under this Plan shall be governed by the Reimbursement Agreement. The inclusion of Eligible Activities and estimates of costs to be reimbursed in this Plan are intended to authorize the FBRA to fund such reimbursements and does not obligate the FBRA or the City to fund any reimbursement or to enter into the Reimbursement Agreement providing for the reimbursement of any costs for which tax increment revenues may be captured under this Plan, or which are permitted to be reimbursed under this Plan in the absence of tax increment revenues being generated from the Property. The amount and source of any tax increment revenues that will be used for purposes authorized by this Plan, and the terms and conditions for such use and upon any reimbursement of the expenses permitted by this Plan, will be provided solely under the Reimbursement Agreement contemplated by this Plan.

Unless otherwise agreed upon by the Developer, the FBRA, and the State of Michigan, the FBRA shall not incur any note or bonded indebtedness to finance the purposes of this Plan.

Interest shall be paid under this Plan as provided in the Reimbursement Agreement, provided that to the extent that the Michigan Strategic Fund or Michigan Department of Environment, Great Lakes and Energy (EGLE) does not approve the payment of interest on an eligible activity with School Taxes, interest shall not accrue or be paid under this Plan with respect to the cost of such Eligible Activity from School Taxes. Unless otherwise agreed upon by the Developer, the FBRA, and the State of Michigan, the FBRA will approve interest on the local portion of the reimbursement to the extent that the projected internal rate of return to the Developer does not exceed twenty (20%), as more specifically stated in the Reimbursement Agreement.

Reimbursements under the Reimbursement Agreement shall not exceed the cost of Eligible Activities permitted under this Plan, plus the 15% contingency factor and approved interest.

**F. Duration of Plan (Section 13(2)(f))**

Subject to Section 13b(16) of Act 381, the beginning date of capture of tax increment revenues for each eligible property shall occur in accordance with the TIF table described in **Exhibit F**. As the tax increment revenue table is an estimate/projection based on certain assumptions, the repayment period may exceed that depicted in the table. In no event, however, shall this Plan extend beyond the maximum term allowed by Section 13(2)(f) of Act 381 for the duration of this Plan.

Furthermore, this Plan, or any subsequent amendment thereto, may be abolished or terminated in accordance with Section 14(8) of Act 381 in the event of any of the following:

a. The governing body may abolish this Plan (or any subsequent amendment thereto) when it finds that the purposes for which this Plan was established have been accomplished.

b. The governing body may terminate this Plan (or any subsequent amendment thereto) if the project for which Eligible Activities were identified in this Plan (or any subsequent amendment thereto) fails to occur with respect to the eligible property for at least five (5) years following the date of the governing body resolution approving this Plan (or any subsequent amendment thereto), provided that the governing body first does both of the following:

(i) gives 30 days' written notice to the Developer at its last known address by certified mail or other method that documents proof of delivery attempted; and

(ii) provides the Developer with an opportunity to be heard at a public meeting.

Notwithstanding anything in this subsection to the contrary, this Plan (or any subsequent amendment thereto) shall not be abolished or terminated until the principal and interest on bonds, if any, issued under Section 17 of Act 381 and all other obligations to which the tax increment revenues are pledged have been paid or funds sufficient to make the payment have been identified or segregated.

**G. Effective Date of Inclusion in Brownfield Plan**

The Property will become a part of this Plan on the date this Plan is approved by the governing body (City Council).

**H. Displacement/Relocation of Individuals on Eligible Property (Section 13(2)(i-l))**

There are no persons or businesses residing on the eligible property and no occupied residences will be acquired or cleared, therefore there will be no displacement or relocation of persons or businesses under this Plan.

**I. Local Brownfield Revolving Fund ("LBRF") (Section 8; Section 13(2)(m))**

The FBRA has established a Local Brownfield Revolving Fund (LBRF). The LBRF will consist of all tax increment revenues authorized to be captured and deposited in the LSRRF, as specified in Section 13(5) of Act 381, under this Plan and any other plan of the FBRA. It may also include funds appropriated or otherwise made available from public or private sources.

The amount of tax increment revenue authorized for capture and deposit in the LBRF is estimated as depicted in the 30 Year Cash Flow Projection Table present in **Attachment F**. All funds, if any, deposited in the LBRF shall be used in accordance with Section 8 of Act 381.

**J. Brownfield Redevelopment Fund (Section 8a; Section 13(2)(m))**

The FBRA shall pay to the Department of Treasury at least once annually an amount equal to 3 mills of the taxes levied under the state education tax, 1993 PA 331, MCL 211.901 to 211.906, that are captured under this Plan for up to the first twenty-five (25) years of the duration of capture of tax increment revenues for each eligible property included in this Plan. If the FBRA pays an amount equal to 3 mills of the taxes levied under the state education tax, 1993 PA 331, MCL 211.901 to 211.906, on a parcel of eligible property to the Department of Treasury under Section 13b(14) of Act 381, the percentage of local taxes levied on that parcel and used to reimburse Eligible Activities for the Project under this Plan shall not exceed the percentage of local taxes levied on that parcel that would have been used to reimburse Eligible Activities for the Project under this Plan if the 3 mills of the taxes levied under the state education tax, 1993 PA 331, MCL 211.901 to 211.906, on that parcel were not paid to the Department of Treasury under Section 13b(14) of Act 381.

**K. Developer's Obligations, Representations and Warrants**

The Developer and its affiliates shall comply with all applicable laws, ordinances, executive orders, or other regulations imposed by the City or any other properly constituted governmental authority with respect to the Property and shall use the Property in accordance with this Plan.

The Developer, at its sole cost and expense, shall be solely responsible for and shall fully comply with all applicable federal, state, and local relocation requirements in implementing this Plan, if any.

The Developer represents and warrants that a Phase I Environmental Site Assessment ("ESA"), and if appropriate, a Phase II ESA, Baseline Environmental Assessment, and Due Care Plan or Response Activity Plan, pursuant to Part 201 of Michigan's Natural Resources and Environmental Protection Act (MCL 324.20101 *et seq.*), have been performed on the Property ("Environmental Documents"). Attached hereto as **Attachment G** is the City of Flint's Department of Buildings, Safety Engineering and Environmental acknowledgement of its receipt of the Phase I ESA, Phase II ESA and Baseline Environmental Assessment (BEA).

The Developer intends to include a City of Flint Land Bank Authority, Genesee County Land Bank Authority or State of Michigan Land Bank financing component, to be determined at a later date, depending upon the needs of the Project.

Except as otherwise agreed to by the FBRA, any material breach of a material representation or warranty contained in this Plan shall render the Plan invalid, subject to the Developer's reasonable opportunity to investigate and cure as described in the Reimbursement Agreement. Prior to any such invalidity, FBRA shall provide Developer written notice of the Developer's alleged breach and the opportunity to either refute the allegation or cure the breach within a reasonable period of time. Notwithstanding the foregoing, any irregularity may be waived by the FBRA, Flint City Council, MEDC/MSF or EGLE.



Exhibit A  
PROPOSED DUPONT INDUSTRIAL FACILITY  
Brownfield Redevelopment Plan

With the approval of this Brownfield Plan, it is the specific intention of the FBRA to authorize and support: (1) the preparation and submittal of an Act 381 Work Plan for approval by EGLE and MEDC/MSF, (2) application for an IFT Abatement under P.A. 198 of 1974, as amended; (3) grant or loan and other available incentives, including EGLE grants and loans, USEPA grants and loans, Genesee County grants and loans, and (3) other possible sources of incentives related to the Eligible Investments made by Developer as part of this project. It is understood that any such tax abatement may extend the currently depicted repayment period and that any such grant award may off-set the need for TIR reimbursement under the Plan or any such loan may use the TIR to repay a loan.

It should be noted that as part of the long term lease arrangement between Developer and Tenant, all proceeds from the Brownfield Plan TIR capture may be assigned to and accrue to the benefit of an entity to be identified in the Reimbursement Agreement which shall be deemed to be the Qualified Taxpayer under the Plan.

23708938 | 9

Exhibit A  
PROPOSED DUPONT INDUSTRIAL FACILITY  
Brownfield Redevelopment Plan

**III. ATTACHMENTS**

Exhibit A  
PROPOSED DUPONT INDUSTRIAL FACILITY  
Brownfield Redevelopment Plan

**ATTACHMENT A**

**Site Map**

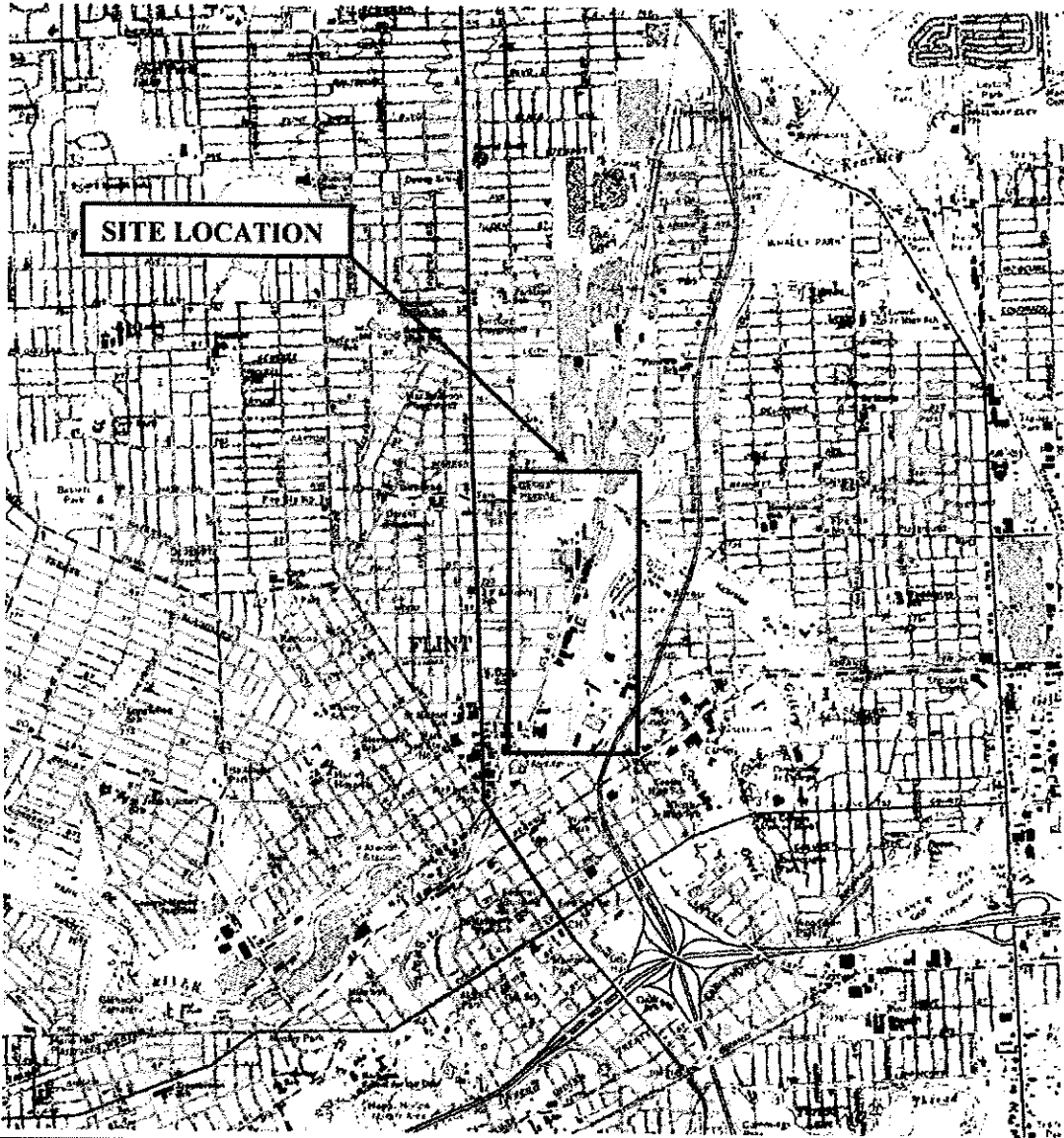

**REFERENCE**  
 USGS 7.5 MIN TOPOGRAPHIC QUADRANGLE  
 FLINT NORTH, MICHIGAN  
 DATED: 1983  
 SCALE: 1: 24000



**FIGURE 1: SITE LOCATION MAP**

**Former DuPont Industrial Facility**

James P. Cole Boulevard  
 Flint, Genesee County, Michigan 48503

PROJECT: 2020041601.01

DATE: 8/28/2020

PREPARED BY: NGM

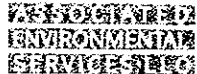

Environmental Services •  
 Land Development • Real  
 Estate Consulting

40701 Woodward Avenue, Suite 50  
 Bloomfield Hills, Michigan 48304  
 Tel (248) 203-9898 Fax (248) 647-0526  
 Email: [info@associatedenvironmental.net](mailto:info@associatedenvironmental.net)  
 Web: [www.associatedenvironmental.net](http://www.associatedenvironmental.net)

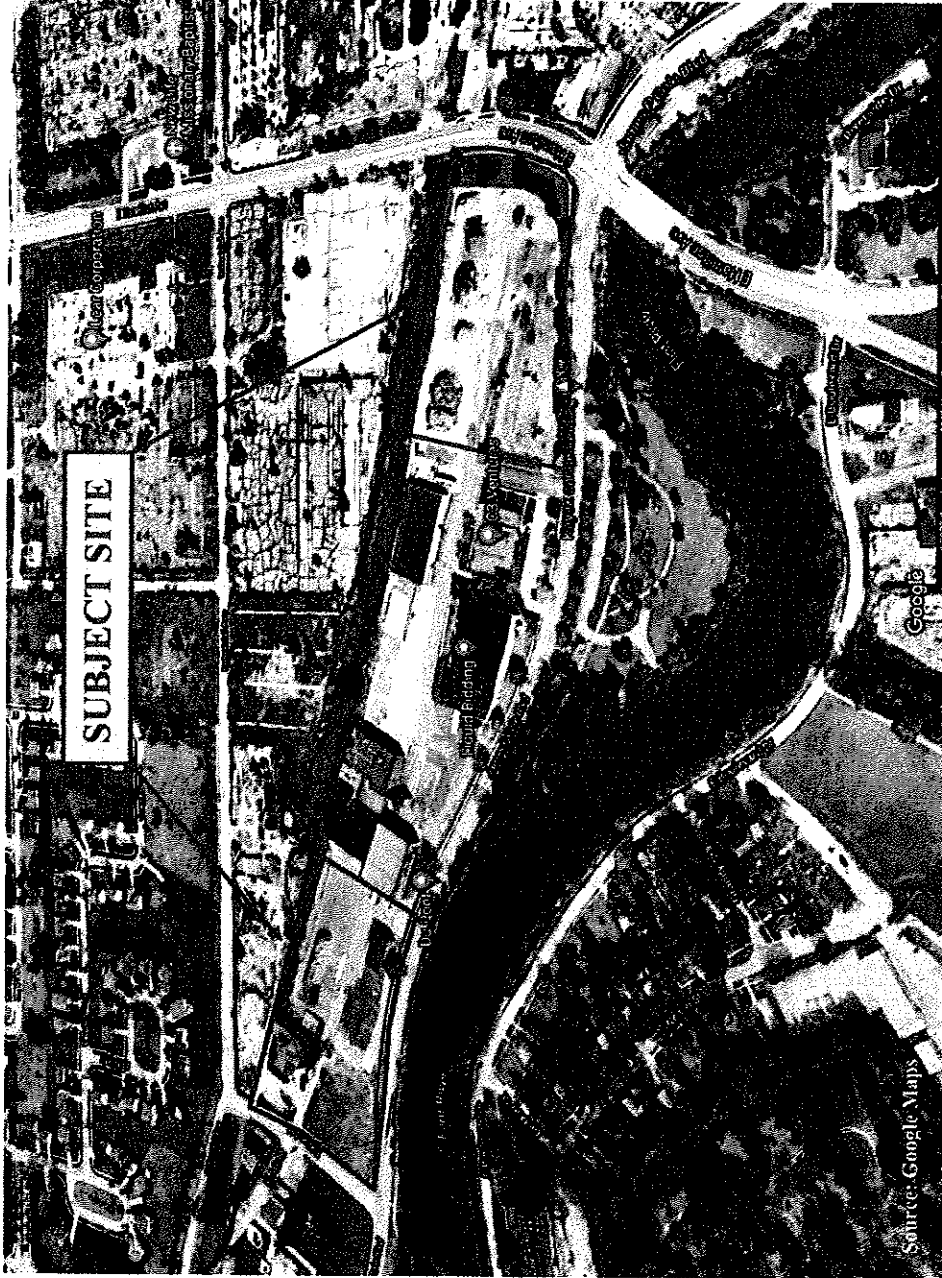

**FIGURE 2: AERIAL SITE MAP**  
 Former DuPont Industrial Facility  
 James P. Cole Boulevard  
 Flint, Genesee County, Michigan 48503

**ASSOCIATED ENVIRONMENTAL MANAGEMENT SERVICES, INC.**  
 Environmental Services •  
 Land Development • Real  
 Estate Consulting

PROJECT: 2020041601.01  
 DATE: 8/28/20  
 PREPARED BY: NGM

40701 Woodward, Suite 50  
 Bloomfield Hills, Michigan 48304  
 Tel: (248) 203-9898  
 Fax: (248) 647-0526  
 E: [info@associatedenvironmental.net](mailto:info@associatedenvironmental.net)  
 W: [www.associatedenvironmental.net](http://www.associatedenvironmental.net)

Exhibit A  
PROPOSED DUPONT INDUSTRIAL FACILITY  
Brownfield Redevelopment Plan

**ATTACHMENT B**

**Legal Descriptions of Eligible Property to which the Plan Applies**



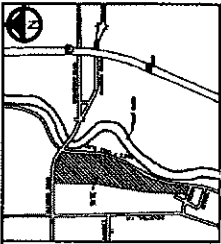

**LEGEND**

(Symbol)	Property Line
(Symbol)	Right of Way
(Symbol)	Utility Line
(Symbol)	Setback Line
(Symbol)	Survey Point
(Symbol)	Corner Marking
(Symbol)	Survey Station
(Symbol)	Property Area
(Symbol)	Right of Way Area
(Symbol)	Utility Area
(Symbol)	Setback Area

**NOTE:**  
 LOCATION OF ALL UTILITIES BY CONTRACTOR. OWNER TO VERIFY LOCATION OF ALL UTILITIES BY CONTRACTOR. OWNER TO VERIFY LOCATION OF ALL UTILITIES BY CONTRACTOR.



**ADJACENT PROPERTIES:**  
 CHESAPEAKE & OHIO RAILWAY PROPERTY  
 OLD RAIL ROAD PROPERTY  
 CHESAPEAKE & OHIO RAILWAY PROPERTY  
 OLD RAIL ROAD PROPERTY

**ADJACENT PROPERTIES:**  
 CHESAPEAKE & OHIO RAILWAY PROPERTY  
 OLD RAIL ROAD PROPERTY  
 CHESAPEAKE & OHIO RAILWAY PROPERTY  
 OLD RAIL ROAD PROPERTY

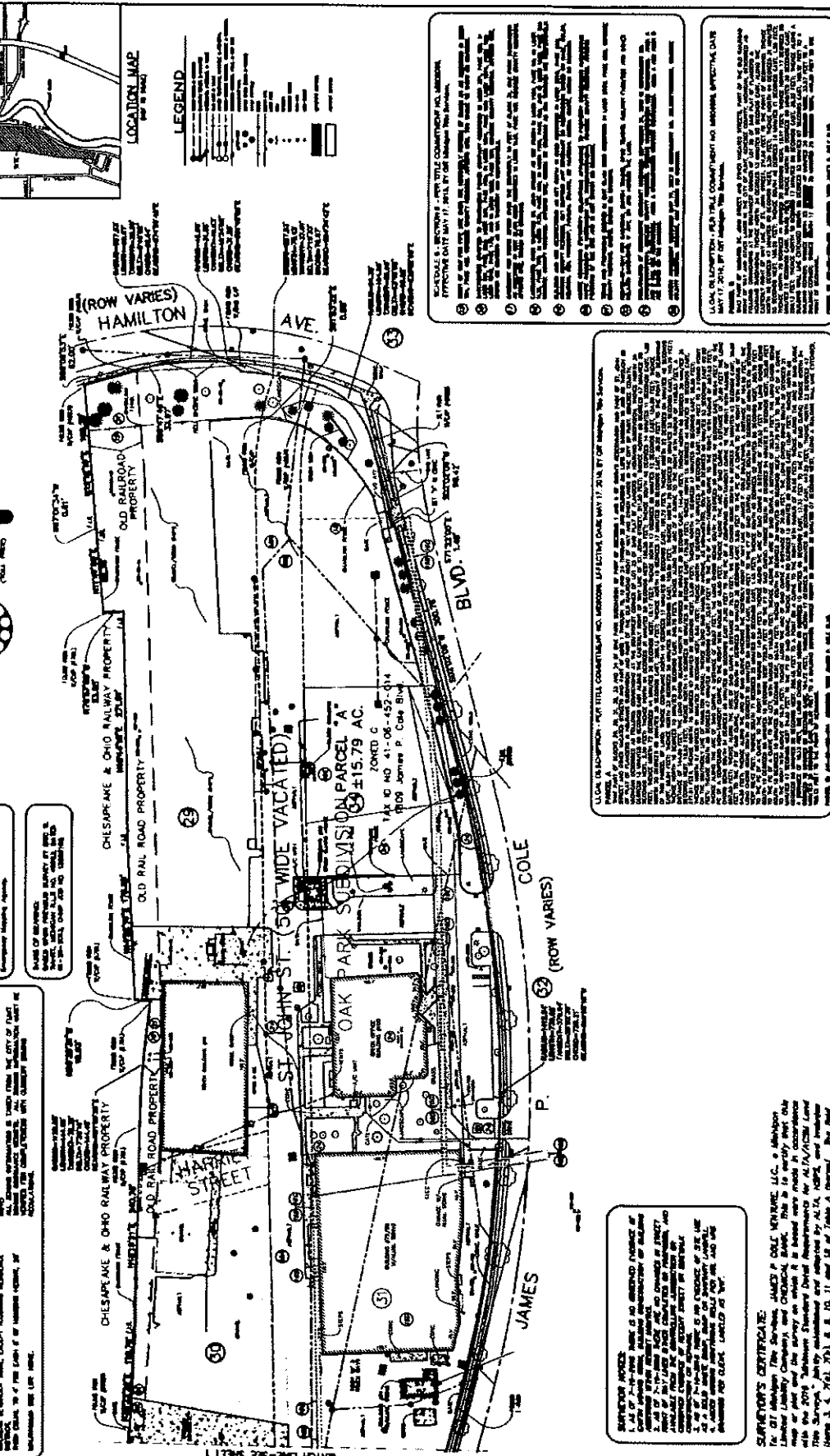

**STATEMENTS:**  
 I, the undersigned, being duly qualified in the State of Ohio, do hereby certify that the foregoing is a true and correct copy of the original survey as shown to me by the owner, and that the same has been compared with the original survey and found to be correct.

**LOCAL JURISDICTION:**  
 THIS TITLE COMMITMENT AND INSTRUMENT EFFECTIVE DATE MAY 17, 2018, BY THE SUPERVISOR OF THE COUNTY OF OHIO, IS SUBJECT TO THE SUPERVISOR'S REVIEW AND APPROVAL.

**LOCAL JURISDICTION:**  
 THIS TITLE COMMITMENT AND INSTRUMENT EFFECTIVE DATE MAY 17, 2018, BY THE SUPERVISOR OF THE COUNTY OF OHIO, IS SUBJECT TO THE SUPERVISOR'S REVIEW AND APPROVAL.

**SURVEYOR'S CERTIFICATE:**  
 I, the undersigned, being duly qualified in the State of Ohio, do hereby certify that the foregoing is a true and correct copy of the original survey as shown to me by the owner, and that the same has been compared with the original survey and found to be correct.

DATE OF SURVEY	5/17/2018
DATE OF INSTRUMENT	5/17/2018
DATE OF RECORDATION	5/17/2018
DATE OF INDEXING	5/17/2018
DATE OF CLOSING	5/17/2018

**ALTA / ACSM LAND TITLE SURVEY**  
 PART OF THE 64 OF SECTION 6, T19R, R10E  
 CITY OF PLINT, CHESTER COUNTY, MICHIGAN

**MERIDIAN**  
 LAND SURVEYING  
 1109 James P. Cole Blvd  
 Plint, Michigan 48870  
 (517) 764-1111

**7/29/2018**  
 Date  
 JAMES P. COLE  
 Michigan Professional Surveyor No. 46678



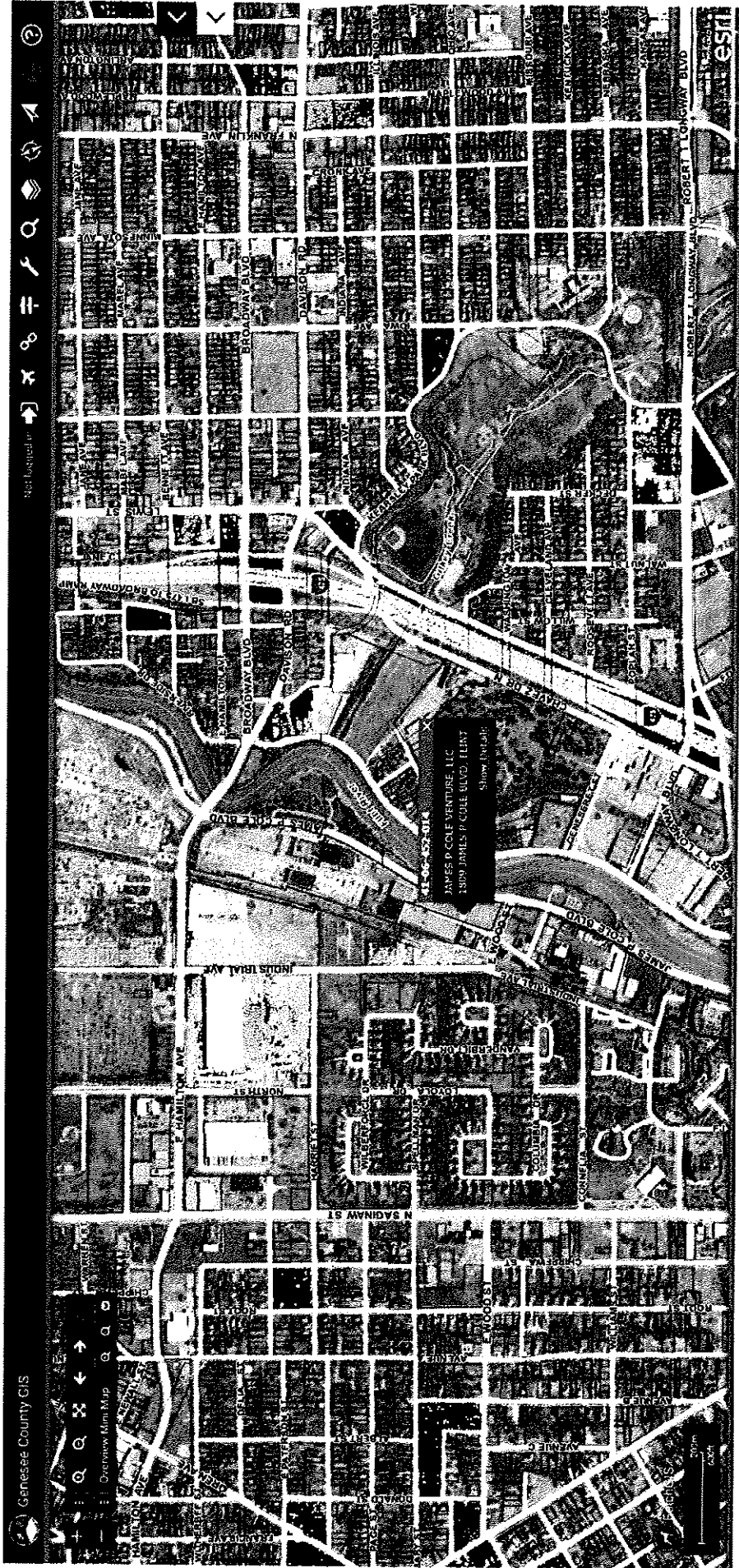



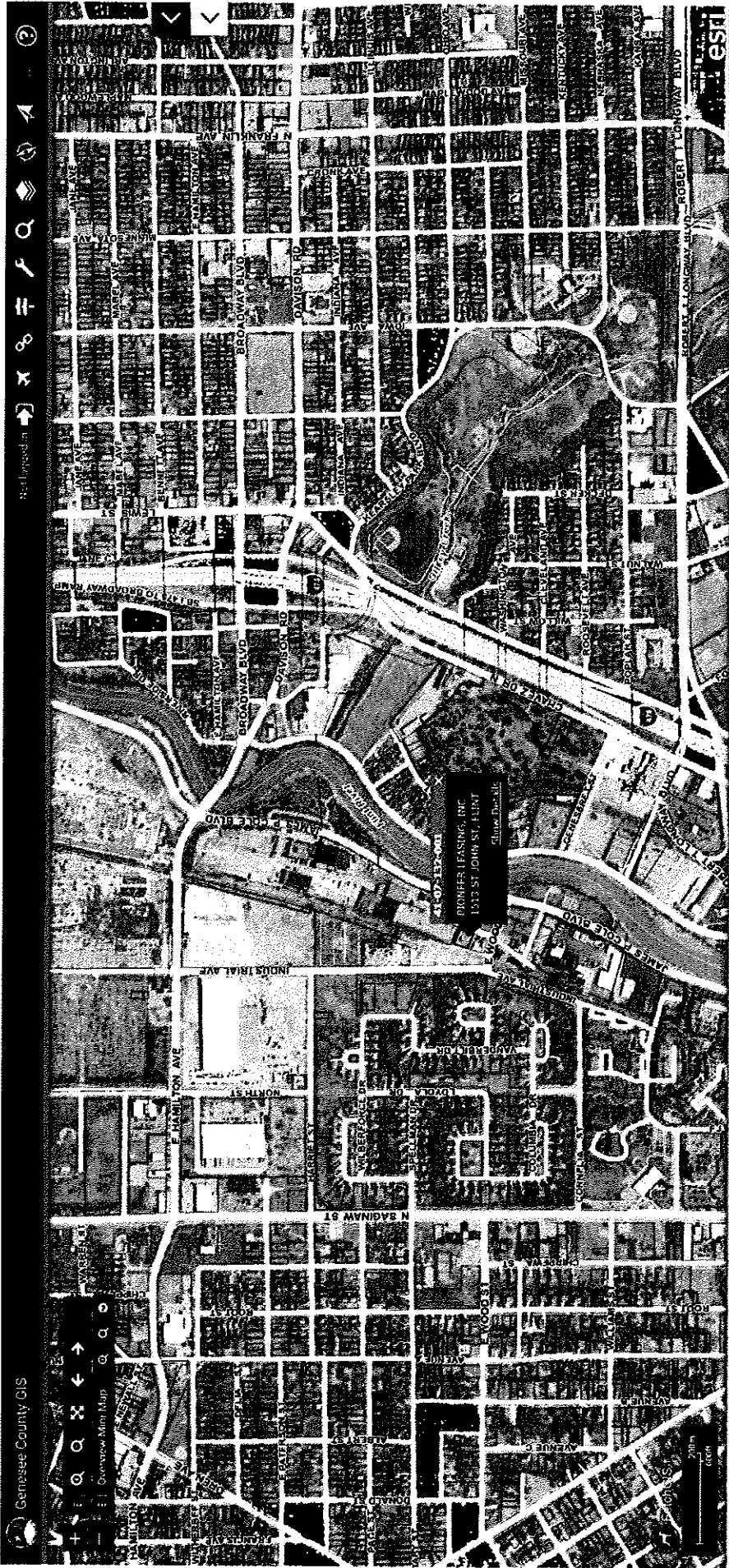



**ATTACHMENT C**

**Project Description – See attached Project Description**

**Project Summary**

<b>Type of Use:</b>	Industrial
<b>Square Footage:</b>	Approximately 110,578 square feet of existing building will remain and undergo renovations with the remaining buildings being demolished to make way for an additional 190,700 square feet of proposed new construction buildings, all on 17.99 acres of improved commercial and industrial land
<b>Number of Housing Units:</b>	Not Applicable
<b>Total Investment:</b>	\$14,250,000.00 (excluding land costs) by Developer, plus additional investments for Furniture, Fixtures and Equipment (FF&E) will be made by individual Tenants
<b>Additional Incentives:</b>	In addition to Brownfield TIF, Developer is seeking tax abatements, Grants and Loans
<b>Estimated Jobs – Construction:</b>	67.5 FTE Jobs over 10 month estimated construction period
<b>Estimated Jobs – Permanent:</b>	TBD based on tenants recruited for occupancy
<b>Project Timeline:</b>	Developer intends to start redevelopment activities after final approval of all incentives

# Attachment C

## Brownfield Plan for James P Cole Venture, LLC

*Provide a description of the project to be completed at the Property (the "Project")*

*Include details regarding development team, total investment amount, description of project use, number of temporary and permanent jobs, and additional financing incentives (IFT). See attached for Project renderings.*

### **Project Description**

The proposed redevelopment site is the former DuPont Industrial Facility located at 1809 James P. Cole Boulevard in Flint, Genesee County, Michigan 48503 (the "Property").

The Property is a currently proposed to be redeveloped into a multi-tenant multi-building industrial park. According to a site plan provided by Client, approximately 110,578 square feet of existing building will remain and undergo renovations with the remaining buildings being demolished to make way for an additional 190,700 square feet of proposed new construction buildings, all on 17.99 acres of improved commercial and industrial land (the "Project").

The existing structures and buildings have been mostly unoccupied for several years. According to a Site Plan provided by Developer, approximately 110,578 square feet of existing building will remain and undergo renovations with the remaining buildings being demolished to make way for an additional 190,700 square feet of proposed new construction buildings, all on 17.99 acres of improved commercial and industrial land.

The completed development will include two single or multiple tenant structures each of which can be expanded to accommodate growth of an existing tenant or additional tenants within the proposed structures.

The Project will be undergoing site plan and zoning review by the City of Flint Engineering Department and Planning & Development Departments, and is therefore subject to change as part of the approval processes. The Project is currently estimated to be an estimated \$14,250,000.00 (excluding land costs) investment by Developer plus any furniture, fixtures and equipment (FF&E) and other Personal Property of the proposed tenants (Operators).

Developer does not currently employ any employees at the Property as there are no existing operations.

The development of the Project on the Property is comprised of two proposed new buildings (Building #1 and Building #2). The completion of this Project is estimated to create an average of 33.8 Full Time Equivalent (FTE) construction jobs per year during the nine (9) month estimated construction phase (.8 year) for each of the buildings comprising the Project within the City of Flint, Genesee County, Michigan resulting in an estimated total of 67.5 FTE jobs with an annualized construction payroll of \$4,375,800.00 or more per year for the construction phase (estimated \$3,281,850.00 or more per Building for a total Project construction payroll of \$6,563,700.00 using FTE calculations).

As the proposed tenants for the new buildings have not been identified at this time, the actual estimated new full-time jobs being created by the Project are not yet determined. However, using U.S. Energy Information Administration (USEIA), Office of Energy Consumption and Efficiency Statistics, job creation can be estimated based on the proposed building square footage and national ratios for jobs on a per square foot basis. As the two new industrial buildings are proposed to be 90,000 ft<sup>2</sup> and 100,000 ft<sup>2</sup> and based on an the USEIA data of "Median square feet per worker" of 1,442 ft<sup>2</sup>, the estimated new jobs per building to be created are 62.4 and 69.3, respectively.

See: <https://www.eia.gov/consumption/commercial/data/2012/bc/cfm/b2.php>

According to Payscale.com, the "Average Production Worker Hourly Pay in Flint, Michigan is \$13.24."

See:

[https://www.payscale.com/research/US/Job=Production\\_Worker/Hourly\\_Rate/32d28c9e/Flint-MI](https://www.payscale.com/research/US/Job=Production_Worker/Hourly_Rate/32d28c9e/Flint-MI)

Based on the foregoing projections, the estimated new permanent FTE jobs payroll being created by the Project is 62.4 FTE X \$13.24/Hour for 40 hours per week for 52 weeks/year = \$1,718,812.76 and 69.3 FTE X \$13.24/Hour for 40 hours per week for 52 weeks/year = \$1,909,791.96 or a total estimated payroll of **\$3,628,604.72**.

#### **Development Team**

##### **Developer/Entity**

James P Cole Venture, LLC  
Attn: Ms. Mona Navitsky  
c/o Dearborn Capital Partners, LLC  
980 North Michigan, Suite 1620  
Chicago, IL 60611  
Attn: Mr. Brien Wloch; Managing Member  
M: (312) 543-1250  
E: [mona.navitsky@dearcapcre.com](mailto:mona.navitsky@dearcapcre.com)

##### **Entity Members**

Please see the attached Ownership Description

##### **Brownfield Redevelopment Consultant and Primary Point of Contact**

Mr. Nicholas G. Maloof, RPG  
President and General Counsel  
Associated Environmental Services, LLC  
40701 Woodward Avenue, Suite 50  
Bloomfield Hills, Michigan 48304  
T (248) 203-9898  
F (248) 647-0526  
M (248) 250-2525  
E [ngm@associatedenvironmental.net](mailto:ngm@associatedenvironmental.net)  
W [www.associatedenvironmental.net](http://www.associatedenvironmental.net)

**Primary Environmental Consultant for Developer**

To Be Determined (TBD)

T ( ) -

M ( ) -

E \_\_\_\_\_

W www. \_\_\_\_\_

**Status of the site  
planning/permitting  
process**

The Project will be undergoing site plan and zoning review by the City of Flint Engineering Department and Planning & Development Departments, and is therefore subject to change as part of the approval processes. The Project is currently estimated to be an estimated \$14,250,000.00 (excluding land costs) investment by Developer plus any furniture, fixtures and equipment (FF&E) and other Personal Property of the proposed tenants (Operators).

**Other Incentives**

In addition to Brownfield TIF, Developer intends to apply for Grants, Loans and Job Training incentives.

Tennant(s)/Occupant(s) intend to apply for an Industrial Facilities Tax Abatement under the Plant Rehabilitation and Industrial Development Districts Act, P.A. 198 of 1974, as amended for a 12 year period.

See attached for Project drawings and renderings.



**Job Creation and Economic Development**

completion of this Project is estimated to create an average of 33.8 Full Time Equivalent (FTE) construction jobs per year during the nine (9) month estimated construction phase (.8 year) for each of the buildings comprising the Project within the City of Flint, Genesee County, Michigan resulting in an estimated annualized construction payroll of \$4,375,800.00 or more per year for the construction phase (estimated \$3,281,850.00 or more per Building for a total Project construction payroll of \$6,563,700.00 using FTE calculations). As the proposed tenants for the Project are unknown, AES projected the estimated number of jobs using U.S. Energy Information Administration (USEIA), Office of Energy Consumption and Efficiency Statistics, job creation can be estimated based on the proposed building square footage and national ratios for jobs on a per square foot basis. AES also obtained and used information on hourly wages from Payscale.com. According to Payscale.com, the "Average Production Worker Hourly Pay in Flint, Michigan is \$13.24. As the two new industrial buildings are proposed to be 90,000 ft2 and 100,000 ft2 and based on an the USEIA data of "Median square feet per worker" of 1,442 ft2, the estimated new jobs per building to be created are 62.4 FTE and 69.3 FTE, respectively. Based on the foregoing projections, the estimated new permanent FTE jobs payroll being created by the Project is 62.4 FTE X \$13.24/Hour for 40 hours per week for 52 weeks/year = \$1,718,812.76 and 69.3 FTE X \$13.24/Hour for 40 hours per week for 52 weeks/year = \$1,909,791.96 or a total estimated payroll of \$3,628,604.72. Please see the tables below for a

**Table 1: Construction Phase Job Creation and Direct Economic Impact**

Phase of Construction	Job Classification	Typical Hourly Rate	Typical Hours Worked (Weekly)	Typical Annual Salary	Number of Jobs Related to Project (Average per year)	Total Annualized Payroll Related to Project	Duration of Jobs in Years Created by Project (in years based on # months construction)	Full-time Equivalent (FTE) Jobs	Total Project Related Payroll (salary/wages & benefits only)
Building #1: Site Preparation & Vertical Construction	Construction Tradesmen and affiliated workers	\$46.75	40	\$97,240.00	45	\$4,375,800.00	0.8	33.8	\$3,281,850.00
Building #2: Site Preparation & Vertical Construction	Construction Tradesmen and affiliated workers	\$46.75	40	\$97,240.00	45	\$4,375,800.00	0.8	33.8	\$3,281,850.00
<b>Construction Phases Total</b>					<b>90</b>	<b>\$8,751,600.00</b>	<b>0.8</b>	<b>67.5</b>	<b>\$6,563,700.00</b>

Average Hourly =	\$46.75	Phase	Duration (Months)	Duration as Fraction of Year
Average Weekly =	\$1,870.00	Site Preparation	1.0	0.1
Average Annual =	\$97,240.00	Vertical Const.	8.0	0.7
Total Annualized Payroll =	\$4,375,800.00	<b>Total</b>	<b>9.0</b>	<b>0.8</b>

**Table 2: Post Construction Phase / Permanent Job Creation and Direct Economic Impact**

Phase of Operation	Job Classification	Typical Hourly Rate	Typical Hours Worked (Weekly)	Typical Annual Salary	Number of Direct Jobs Related to Project (Average per year)	Total Annual Payroll Related to Project	Duration of Jobs Created by Project	Full-time Equivalent (FTE) Jobs	Total Project Related Payroll (salary/wages only)
Building #1	Warehouse, Production	\$13.24	40	\$27,539.20	62.4	\$1,718,446.08	Permanent	TBD	\$1,718,446.08
Building #1	Warehouse, Production	\$13.24	40	\$27,539.20	62.4	\$1,718,446.08			\$1,718,446.08
Building #2	Warehouse, Production	\$13.24	40	\$27,539.20	69.3	\$1,908,466.56	Permanent	TBD	\$1,908,466.56
Building #2					69.3	\$1,908,466.56			\$1,908,466.56
<b>Total Estimated Jobs and Project Payroll (Annually)</b>						<b>\$3,626,912.64</b>			<b>\$3,626,912.64</b>

As the proposed tenants for the Project are unknown, AES projected the estimated number of jobs using U.S. Energy Information Administration (USEIA), Office of Energy Consumption and Efficiency Statistics, job creation can be estimated based on the proposed building square footage and national ratios for jobs on a per square foot basis. AES also obtained and used information on hourly wages from Payscale.com. According to Payscale.com, the "Average Production Worker Hourly Pay in Flint, Michigan is \$13.24. As the two new industrial buildings are proposed to be 90,000 ft<sup>2</sup> and 100,000 ft<sup>2</sup> and based on an the USEIA data of "Median square feet per worker" of 1,442 ft<sup>2</sup>, the estimated new jobs per building to be created are 62.4 FTE and 69.3 FTE, respectively. Based on the foregoing projections, the estimated new permanent FTE jobs payroll being created by the Project is 62.4 FTE X \$13.24/Hour for 40 hours per week for 52 weeks/year = \$1,718,812.76 and 69.3 FTE X \$13.24/Hour for 40 hours per week for 52 weeks/year = \$1,909,791.96 or a total estimated payroll of \$3,628,604.72. Please see the tables below for a summary of direct economic benefits resulting from the Project.







Exhibit A  
PROPOSED DUPONT INDUSTRIAL FACILITY  
Brownfield Redevelopment Plan

**ATTACHMENT D**

**Supportive Letters**

**ATTACHMENT E**

**Estimated Cost of Eligible Activities Tables**

**ESTIMATED COST OF ELIGIBLE ACTIVITIES SUMMARY**

Description of Eligible Activities	Estimated Cost Bldg#1	Estimated Cost Bldg#2	Activity Total <sup>1</sup>
Brownfield Plan and Act 381 Work Plan			\$30,000.00
Baseline Environmental Assessment Activities	\$22,900.00	\$22,900.00	\$45,800.00
Due Care Activities	\$328,500.00	\$321,500.00	\$650,000.00
Response Activities	\$83,500.00	\$83,500.00	\$167,000.00
Demolition Activities	\$50,000.00	\$225,000.00	\$275,000.00
Infrastructure Improvements	\$472,948.00	\$464,360.00	\$937,308.00
Site Preparation	\$218,200.00	\$218,200.00	\$436,400.00
<b>Sub-Total Site Eligible Activities</b>	<b>\$1,176,048.00</b>	<b>\$1,335,460.00</b>	<b>\$2,541,508.00</b>
FBRA Administration Costs			\$973,411.00
Local Site Remediation Revolving Fund			\$1,044,652.00
<b>Total Estimated Cost to be Funded Through TIF</b>			<b>\$4,559,571.00</b>

<sup>1</sup>Does not include 15% Act 381 Contingency

**TABLE 1 - TOTAL PROPOSED EGLE ELIGIBLE ACTIVITY COSTS  
BROWNFIELD PLAN  
PROPOSED FORMER DUPONT SITE REDEVELOPMENT - Phase 1 (90,000 sq ft bldg)  
CITY OF FLINT, GENESEE COUNTY, MICHIGAN**

Eligible Activity Description	Brownfield Property Cost		
<b>DEPARTMENT SPECIFIC ACTIVITIES (MCL §125.2652(2)(i)) ELIGIBLE ACTIVITY COSTS</b>			
<b>Baseline Environmental Assessments (MCL §125.2652(2)(i))</b>	<b>Local TIF Capture Only</b>	<b>State and Local TIF Capture</b>	<b>TOTAL</b>
Phase I Environmental Site Assessment	\$0	\$2,400	\$2,400
Phase II Environmental Site Assessment	\$0	\$15,000	\$15,000
Baseline Environmental Assessment	\$0	\$3,500	\$3,500
7a Due Care Plan	\$0	\$2,000	\$2,000
<b>Due Care Activities (MCL §125.2652(2)(i) and (m))</b>			
Section 7aCA Due Care Plan - Revisions/Documentation of Due Care Compliance	\$0	\$4,500	\$4,500
Additional Due Care Phase II ESA Environmental Due Diligence Activities	\$0	\$40,000	\$40,000
Additional Due Care Phase II ESA Environmental Due Diligence Reporting Activities	\$0	\$3,500	\$3,500
Treatment/Disposal of Contaminated Groundwater During Construction (if necessary)	\$0	\$40,000	\$40,000
Soil Staging, Loading, Transportation, and Disposal	\$0	\$35,000	\$35,000
Soil Verification Sampling (if necessary)	\$0	\$25,000	\$25,000
Soil Backfill (Soil, soil placement & compaction)	\$0	\$5,000	\$5,000
Health & Safety Plan	\$0	\$2,500	\$2,500
Project Management	\$0	\$15,000	\$15,000
Soil Erosion Measures	\$0	\$3,000	\$3,000
Incremental Costs for Greenspace Encapsulation (as necessary)	\$0	\$30,000	\$30,000
Incremental Costs for Encapsulation (Engineering controls for Building and Parking)	\$0	\$50,000	\$50,000
Soil Vapor Assessment and Pilot Test	\$0	\$5,000	\$5,000
Soil Vapor Barrier / Sub-slab Depressurization System	\$0	\$65,000	\$65,000
Work Plans, Engineering, Specifications and Reports	\$0	\$5,000	\$5,000
<b>Response Activities (MCL §125.2652(2)(i) and (o)(i) and (ii))</b>			
Hoist, Trench and Other former Equipment Removal Related Activities (if present)	\$0	\$15,000	\$15,000
UST Removal and Closure (if identified during excavation)	\$0	\$50,000	\$50,000
UST Removal Observation, Sampling and Report (if identified during excavation)	\$0	\$12,000	\$12,000
Work Plans, Engineering, Specifications and Reports	\$0	\$6,500	\$6,500
<i>ENVIRONMENTAL COSTS SUBTOTAL</i>			\$434,900
<b>TOTAL ELIGIBLE ACTIVITY COSTS PLUS CONTINGENCY AND ADMINISTRATIVE COSTS</b>			
<b>Contingency</b>			
Contingency (15% of Subtotal NOT including completed BEA Activities)	\$0.00	\$61,800	\$61,800
Brownfield Plan, Act 381 Work Plan and Related Documents (MCL §125.2652(2)(o)(i)(D))	\$0	\$7,500	\$7,500
<i>ELIGIBLE ACTIVITY COSTS SUBTOTAL</i>			\$504,200
<b>Agency Administrative Costs</b>			
State Act 381 Work Plan Review (No longer charged by State)	\$0	\$0	\$0
<b>DBRA Administrative and Operating Costs (15% of TIR Annually)</b>	\$0	\$0	\$0
<b>GRAND TOTAL</b>			<b>\$504,200</b>



<b>TABLE 2 - TOTAL PROPOSED MSF ELIGIBLE ACTIVITY COSTS</b>	
<b>PROPOSED FORMER DUPONT SITE REDEVELOPMENT - Phase 1 (90,000 ft2 bldg)</b>	
<b>CITY OF FLINT, GENESEE COUNTY, MICHIGAN</b>	
Eligible Activity Description	Brownfield Property Cost
<b>ELIGIBLE ACTIVITIES (MCL 125.2652(2)(o)) MSF ELIGIBLE ACTIVITY COSTS</b>	
<b>Lead, Asbestos and Mold Abatement (MCL §125.2652(2)(o)(i)(G))</b>	
Pre Demolition Hazardous Materials Environmental Assessment (HMEA)	\$0
Bid Specs and Bid Evaluation (for HazMat Abatement)	\$0
Lead, Asbestos and Mold Abatement Consulting, Management, Design and Planning, Air Monitoring	\$0
Site Security (HazMat Abatement and Demolition)	\$0
Pre Demolition Asbestos, Lead and Hazardous Materials Abatement	\$0
<b>Demolition Activities (MCL §125.2652(2)(o)(i)(F))</b>	
Demolition Engineering, Design and Management, Bid Specs and Evaluation	\$15,000
Demolition of Building (Interior and Exterior, Incl Demo & Disp)	\$0
Demolition of Building (Utility disconnect and removal)	\$0
Demolition of Building (Pavement removal)	\$35,000
<b>Infrastructure Improvements (MCL §125.2652(2)(o)(ii)(B))</b>	
Utility Connection & Installation - New site utilities/Utility relocation (water, sewer, gas, etc.)	\$472,948
Utility Connection & Installation - Retention/Detention	\$0
Public Infrastructure - Storm Sewer	\$0
Public Infrastructure - James P. Cole Right-of-Way	\$0
Public Infrastructure -	\$0
Public Infrastructure -	\$0
<b>Site Preparation (MCL §125.2652(2)(o)(ii)(C))</b>	
Geotechnical Testing & Evaluation	\$20,000
Soil Mitigation activities	\$0
Geotechnically Non-viable Soils Removal	\$0
Site Preparation (Exc., Debris removal, etc.)	\$25,000
Site Preparation (Rough Grading, etc.)	\$132,000
Site Preparation (Finished Grading, etc.)	\$28,200
Site Preparation (Specialized foundations)	\$0
Site Preparation (Sheeting, shoring, etc.)	\$0
Site Preparation - Excavation	\$5,000
Site Preparation - Pumping of Groundwater	\$8,000
<b>MSF ELIGIBLE ACTIVITY COSTS SUBTOTAL</b>	
<b>\$741,148</b>	
<b>TOTAL ELIGIBLE ACTIVITY COSTS PLUS CONTINGENCY</b>	
Contingency (15% of Subtotal)	
\$111,172	
Brownfield Plan, Act 381 Work Plan and Related Documents (MCL §125.2652(2)(o)(i)(D))	
\$7,500	
<b>GRAND TOTAL</b>	
<b>\$859,820</b>	

**TABLE 1 - TOTAL PROPOSED EGLE ELIGIBLE ACTIVITY COSTS  
BROWNFIELD PLAN  
PROPOSED FORMER DUPONT SITE REDEVELOPMENT - Phase I (100,000 B2 bldg)  
CITY OF FLINT, GENESEE COUNTY, MICHIGAN**

Eligible Activity Description	Brownfield Property Cost		
<b>DEPARTMENT SPECIFIC ACTIVITIES (MCL §125.2652(2)(l)) ELIGIBLE ACTIVITY COSTS</b>			
	Local TIF Capture Only	State and Local TIF Capture	TOTAL
<b>Baseline Environmental Assessments (MCL §125.2652(2)(l))</b>			
Phase I Environmental Site Assessment	\$0	\$2,400	\$2,400
Phase II Environmental Site Assessment	\$0	\$15,000	\$15,000
Baseline Environmental Assessment	\$0	\$3,500	\$3,500
7a Due Care Plan	\$0	\$2,000	\$2,000
<b>Due Care Activities (MCL §125.2652(2)(l) and (m))</b>			
Section 7aCA Due Care Plan - Revisions/Documentation of Due Care Compliance	\$0	\$4,500	\$4,500
Additional Due Care Phase II ESA Environmental Due Diligence Activities	\$0	\$40,000	\$40,000
Additional Due Care Phase II ESA Environmental Due Diligence Reporting Activities	\$0	\$3,500	\$3,500
Treatment/Disposal of Contaminated Groundwater During Construction (if necessary)	\$0	\$40,000	\$40,000
Soil Staging, Loading, Transportation, and Disposal	\$0	\$35,000	\$35,000
Soil Verification Sampling (if necessary)	\$0	\$25,000	\$25,000
Soil Backfill (Soil, soil placement & compaction)	\$0	\$5,000	\$5,000
Health & Safety Plan	\$0	\$2,500	\$2,500
Project Management	\$0	\$15,000	\$15,000
Soil Erosion Measures	\$0	\$3,000	\$3,000
Incremental Costs for Greenspace Encapsulation (as necessary)	\$0	\$30,000	\$30,000
Incremental Costs for Encapsulation (Engineering controls for Building and Parking)	\$0	\$50,000	\$50,000
Soil Vapor Assessment and Pilot Test	\$0	\$5,000	\$5,000
Soil Vapor Barrier / Sub-slab Depressurization System	\$0	\$58,000	\$58,000
Work Plans, Engineering, Specifications and Reports	\$0	\$5,000	\$5,000
<b>Response Activities (MCL §125.2652(2)(l) and (o)(i) and (ii))</b>			
Hoist, Trench and Other former Equipment Removal Related Activities (if present)	\$0	\$15,000	\$15,000
UST Removal and Closure (if identified during excavation)	\$0	\$50,000	\$50,000
UST Removal Observation, Sampling and Report (if identified during excavation)	\$0	\$12,000	\$12,000
Work Plans, Engineering, Specifications and Reports	\$0	\$6,500	\$6,500
<i>ENVIRONMENTAL COSTS SUBTOTAL</i>			\$427,900
<b>TOTAL ELIGIBLE ACTIVITY COSTS PLUS CONTINGENCY AND ADMINISTRATIVE COSTS</b>			
<b>Contingency</b>			
Contingency (15% of Subtotal NOT including completed BEA Activities)	\$0.00	\$60,750	\$60,750
Brownfield Plan, Act 381 Work Plan and Related Documents (MCL §125.2652(2)(o)(i)(D))		\$7,500	\$7,500
<i>ELIGIBLE ACTIVITY COSTS SUBTOTAL</i>			\$496,150
<b>Agency Administrative Costs</b>			
State Act 381 Work Plan Review (No longer charged by State)	\$0	\$0	\$0
<b>DBRA Administrative and Operating Costs (15% of TIF Annually)</b>	\$0	\$0	\$0
<b>GRAND TOTAL</b>			\$496,150

**TABLE 2 - TOTAL PROPOSED MSF ELIGIBLE ACTIVITY COSTS  
PROPOSED FORMER DUPONT SITE REDEVELOPMENT - Phase 1 (100,000 ft2 bldg)  
CITY OF FLINT, GENESEE COUNTY, MICHIGAN**

Eligible Activity Description	Brownfield Property Cost
<b>ELIGIBLE ACTIVITIES (MCL 125.2652(2)(o)) MSF ELIGIBLE ACTIVITY COSTS</b>	
<b>Lead, Asbestos and Mold Abatement (MCL §125.2652(2)(o)(i)(G))</b>	
Pre Demolition Hazardous Materials Environmental Assessment (HMEA)	\$0
Bid Specs and Bid Evaluation (for HazMat Abatement)	\$0
Lead, Asbestos and Mold Abatement Consulting, Management, Design and Planning, Air Monitoring	\$0
Site Security (HazMat Abatement and Demolition)	\$0
Pre Demolition Asbestos, Lead and Hazardous Materials Abatement	\$0
<b>Demolition Activities (MCL §125.2652(2)(o)(i)(F))</b>	
Demolition Engineering, Design and Management, Bid Specs and Evaluation	\$15,000
Demolition of Building (Interior and Exterior, Incl Demo & Disp)	\$90,000
Demolition of Building (Utility disconnect and removal)	\$25,000
Demolition of Building (Pavement removal)	\$95,000
<b>Infrastructure Improvements (MCL §125.2652(2)(o)(ii)(B))</b>	
Utility Connection & Installation - New site utilities/Utility relocation (water, sewer, gas, etc.)	\$464,360
Utility Connection & Installation - Retention/Detention	\$0
Public Infrastructure - Storm Sewer	\$0
Public Infrastructure - James P. Cole Right-of-Way	\$0
Public Infrastructure -	\$0
Public Infrastructure -	\$0
<b>Site Preparation (MCL §125.2652(2)(o)(ii)(C))</b>	
Geotechnical Testing & Evaluation	\$20,000
Soil Mitigation activities	\$0
Geotechnically Non-viable Soils Removal	\$0
Site Preparation (Exc., Debris removal, etc.)	\$25,000
Site Preparation (Rough Grading, etc.)	\$132,000
Site Preparation (Finished Grading, etc.)	\$28,200
Site Preparation (Specialized foundations)	\$0
Site Preparation (Sheeting, shoring, etc.)	\$0
Site Preparation - Excavation	\$5,000
Site Preparation - Pumping of Groundwater	\$8,000
<b>MSF ELIGIBLE ACTIVITY COSTS SUBTOTAL</b>	<b>\$907,560</b>
<b>TOTAL ELIGIBLE ACTIVITY COSTS PLUS CONTINGENCY</b>	
Contingency (15% of Subtotal)	\$136,134
Brownfield Plan, Act 381 Work Plan and Related Documents (MCL §125.2652(2)(o)(i)(D))	\$7,500
<b>GRAND TOTAL</b>	<b>\$1,051,194</b>

**ATTACHMENT F**

**TIF Tables**

FINAL DRAFT FOR REVIEW AND APPROVAL

Tax Incremental Revenue Capture Estimates  
Former DuPont Facility Redevelopment  
James P. Cole Blvd  
Flint, Genesee County, Michigan  
October 31, 2020

EXHIBIT A: TIF TABLE

Month	1	2	3	4	5	6	7	8	9	10	11	12	13	14	15	16	17
City of Flint	14,000	14,000	14,000	14,000	14,000	14,000	14,000	14,000	14,000	14,000	14,000	14,000	14,000	14,000	14,000	14,000	14,000
County of Genesee	14,000	14,000	14,000	14,000	14,000	14,000	14,000	14,000	14,000	14,000	14,000	14,000	14,000	14,000	14,000	14,000	14,000
State of Michigan	14,000	14,000	14,000	14,000	14,000	14,000	14,000	14,000	14,000	14,000	14,000	14,000	14,000	14,000	14,000	14,000	14,000
<b>Total</b>	<b>42,000</b>	<b>42,000</b>	<b>42,000</b>	<b>42,000</b>	<b>42,000</b>	<b>42,000</b>	<b>42,000</b>	<b>42,000</b>	<b>42,000</b>	<b>42,000</b>	<b>42,000</b>	<b>42,000</b>	<b>42,000</b>	<b>42,000</b>	<b>42,000</b>	<b>42,000</b>	<b>42,000</b>
City of Flint	14,000	14,000	14,000	14,000	14,000	14,000	14,000	14,000	14,000	14,000	14,000	14,000	14,000	14,000	14,000	14,000	14,000
County of Genesee	14,000	14,000	14,000	14,000	14,000	14,000	14,000	14,000	14,000	14,000	14,000	14,000	14,000	14,000	14,000	14,000	14,000
State of Michigan	14,000	14,000	14,000	14,000	14,000	14,000	14,000	14,000	14,000	14,000	14,000	14,000	14,000	14,000	14,000	14,000	14,000
<b>Total</b>	<b>42,000</b>	<b>42,000</b>	<b>42,000</b>	<b>42,000</b>	<b>42,000</b>	<b>42,000</b>	<b>42,000</b>	<b>42,000</b>	<b>42,000</b>	<b>42,000</b>	<b>42,000</b>	<b>42,000</b>	<b>42,000</b>	<b>42,000</b>	<b>42,000</b>	<b>42,000</b>	<b>42,000</b>

Tax Increment Revenue Capture Estimates  
Former DuPont Facility Redevelopment  
James P. Cole Blvd  
Flint, Genesee County, Michigan  
October 31, 2020

EXHIBIT A. TIF TABLE

Entity Name	18	19	20	21	22	23	24	25	26	27	28	29	30	TOTAL
<b>City of Flint</b>														
Adult Education (14.15%)	\$ 0.00	\$ 0.00	\$ 0.00	\$ 0.00	\$ 0.00	\$ 0.00	\$ 0.00	\$ 0.00	\$ 0.00	\$ 0.00	\$ 0.00	\$ 0.00	\$ 0.00	\$ 0.00
Adult Operating Tax	\$ 0.00	\$ 0.00	\$ 0.00	\$ 0.00	\$ 0.00	\$ 0.00	\$ 0.00	\$ 0.00	\$ 0.00	\$ 0.00	\$ 0.00	\$ 0.00	\$ 0.00	\$ 0.00
<b>County of Genesee</b>														
County Operating	\$ 29,786	\$ 30,816	\$ 31,846	\$ 32,876	\$ 33,906	\$ 34,936	\$ 35,966	\$ 36,996	\$ 38,026	\$ 39,056	\$ 40,086	\$ 41,116	\$ 42,146	\$ 421,151
Library	\$ 21,881	\$ 22,811	\$ 23,741	\$ 24,671	\$ 25,601	\$ 26,531	\$ 27,461	\$ 28,391	\$ 29,321	\$ 30,251	\$ 31,181	\$ 32,111	\$ 33,041	\$ 330,330
Flint Operating	\$ 40,883	\$ 41,813	\$ 42,743	\$ 43,673	\$ 44,603	\$ 45,533	\$ 46,463	\$ 47,393	\$ 48,323	\$ 49,253	\$ 50,183	\$ 51,113	\$ 52,043	\$ 510,481
Public Safety	\$ 42,205	\$ 43,135	\$ 44,065	\$ 44,995	\$ 45,925	\$ 46,855	\$ 47,785	\$ 48,715	\$ 49,645	\$ 50,575	\$ 51,505	\$ 52,435	\$ 53,365	\$ 533,066
Wild Fire	\$ 40,321	\$ 41,251	\$ 42,181	\$ 43,111	\$ 44,041	\$ 44,971	\$ 45,901	\$ 46,831	\$ 47,761	\$ 48,691	\$ 49,621	\$ 50,551	\$ 51,481	\$ 514,806
Genesee County Parks	\$ 4,026	\$ 4,116	\$ 4,206	\$ 4,296	\$ 4,386	\$ 4,476	\$ 4,566	\$ 4,656	\$ 4,746	\$ 4,836	\$ 4,926	\$ 5,016	\$ 5,106	\$ 50,986
Parks and Rec	\$ 7,774	\$ 7,864	\$ 7,954	\$ 8,044	\$ 8,134	\$ 8,224	\$ 8,314	\$ 8,404	\$ 8,494	\$ 8,584	\$ 8,674	\$ 8,764	\$ 8,854	\$ 88,514
Genesee Job	\$ 20,417	\$ 20,807	\$ 21,197	\$ 21,587	\$ 21,977	\$ 22,367	\$ 22,757	\$ 23,147	\$ 23,537	\$ 23,927	\$ 24,317	\$ 24,707	\$ 25,097	\$ 250,927
Genesee Job	\$ 6,441	\$ 6,571	\$ 6,701	\$ 6,831	\$ 6,961	\$ 7,091	\$ 7,221	\$ 7,351	\$ 7,481	\$ 7,611	\$ 7,741	\$ 7,871	\$ 8,001	\$ 80,001
Flint Training Fund	\$ 1,842	\$ 1,882	\$ 1,922	\$ 1,962	\$ 2,002	\$ 2,042	\$ 2,082	\$ 2,122	\$ 2,162	\$ 2,202	\$ 2,242	\$ 2,282	\$ 2,322	\$ 23,242
CS Multi Operating	\$ 10,741	\$ 10,881	\$ 11,021	\$ 11,161	\$ 11,301	\$ 11,441	\$ 11,581	\$ 11,721	\$ 11,861	\$ 12,001	\$ 12,141	\$ 12,281	\$ 12,421	\$ 124,241
<b>Local Total</b>	\$ 177,864	\$ 182,764	\$ 187,664	\$ 192,564	\$ 197,464	\$ 202,364	\$ 207,264	\$ 212,164	\$ 217,064	\$ 221,964	\$ 226,864	\$ 231,764	\$ 236,664	\$ 2,366,664
<b>State of Michigan</b>														
Flint School Dist	\$ 15,171	\$ 15,511	\$ 15,851	\$ 16,191	\$ 16,531	\$ 16,871	\$ 17,211	\$ 17,551	\$ 17,891	\$ 18,231	\$ 18,571	\$ 18,911	\$ 19,251	\$ 192,511
CS Multi Dist	\$ 4,106	\$ 4,246	\$ 4,386	\$ 4,526	\$ 4,666	\$ 4,806	\$ 4,946	\$ 5,086	\$ 5,226	\$ 5,366	\$ 5,506	\$ 5,646	\$ 5,786	\$ 57,816
Public Health Dist	\$ 9,510	\$ 9,750	\$ 10,000	\$ 10,250	\$ 10,500	\$ 10,750	\$ 11,000	\$ 11,250	\$ 11,500	\$ 11,750	\$ 12,000	\$ 12,250	\$ 12,500	\$ 125,000
<b>TOTAL MICHIGAN</b>	\$ 28,787	\$ 29,507	\$ 30,227	\$ 30,947	\$ 31,667	\$ 32,387	\$ 33,107	\$ 33,827	\$ 34,547	\$ 35,267	\$ 35,987	\$ 36,707	\$ 37,427	\$ 374,327
<b>Total Tax Increment Revenue (TIR) Available for Capture</b>	\$ 206,651	\$ 212,271	\$ 217,891	\$ 223,511	\$ 229,131	\$ 234,751	\$ 240,371	\$ 245,991	\$ 251,611	\$ 257,231	\$ 262,851	\$ 268,471	\$ 274,091	\$ 2,741,011

FINAL DRAFT FOR REVIEW AND APPROVAL

Tax Increment Revenue Capture Estimates  
 Former DuPont Facility Redevelopment  
 James P. Cole Blvd  
 Flint, Genesee County, Michigan  
 October 31, 2020

EXHIBIT A: TIF TABLE

	1. Municipal Facility Value (\$/sq. ft. x square feet)	2. Millage Rate	3. School Taxable Value	4. Estimated New Tax Incremental Revenue (\$/year)	5. Estimated New Tax Incremental Revenue (\$/year)	6. Estimated New Tax Incremental Revenue (\$/year)	7. Estimated New Tax Incremental Revenue (\$/year)	8. Estimated New Tax Incremental Revenue (\$/year)	9. Estimated New Tax Incremental Revenue (\$/year)
<b>School District</b>									
County District	6.0000	10.0000	22,216,294	222,162.94	\$	41,270.79	\$	615,587	
Flint	2.6800	4.0000	1,437,637	3,806,225.20	\$	400,627	\$	480,627	
Public Safety	4.0000	6.0000	1,437,637	5,745,748.80	\$	594,626	\$	715,626	
Water	9.1748	13.7612	1,437,637	20,787,322.56	\$	2,170,818	\$	2,600,818	
Genesee County Parks	8.2422	12.3633	1,437,637	19,760,436.34	\$	2,058,884	\$	2,488,884	
Police and Fire	6.0000	8.8000	1,437,637	10,547,316.76	\$	1,112,927	\$	1,342,927	
Genesee County	2.7273	4.0000	1,437,637	3,876,222.56	\$	402,137	\$	482,137	
Flint (including Flint)	3.0000	4.4000	1,437,637	5,256,041.24	\$	551,274	\$	661,274	
US Mail Operating	1.9500	2.8500	1,437,637	2,804,789.16	\$	292,504	\$	352,504	
<b>Local Total</b>	<b>41.8463</b>	<b>61.3863</b>	<b>14,376,370</b>	<b>207,873,225.60</b>	\$	<b>21,708,184</b>	\$	<b>26,008,184</b>	
<b>State-Capturable Millages</b>									
Flint School Debt	2.6700	3.9000	1,437,637	3,660,222.56	\$	383,793	\$	463,793	
US Mail Debt	2.7000	3.9500	1,437,637	3,708,222.56	\$	388,421	\$	468,421	
Public Library Debt	1.0000	1.4500	1,437,637	2,084,702.56	\$	218,994	\$	268,994	
<b>TOTAL MILLIS</b>	<b>5.4300</b>	<b>7.9000</b>	<b>14,376,370</b>	<b>203,926,133.28</b>	\$	<b>21,708,184</b>	\$	<b>26,008,184</b>	

Total Tax Increment Revenue (TIR) Available for Capture

2020/2021

FINAL DRAFT FOR REVIEW AND APPROVAL

Tax Increment Revenue Reimbursement Allocation Table  
Former DuPont Facility Redevelopment  
James P. Cole Blvd, Flint, Genesee County, Michigan  
October 31, 2020

Developer Maximum Reimbursement	Proposed Rate	School & Local Taxes	Local-Only Taxes	Total
Rate	16.70%	\$ 3,960,107	\$ 3,960,107	\$ 7,920,214
Local	12.20%	\$ 2,920,052	\$ -	\$ 2,920,052
TOTAL	28.90%	\$ 6,880,159	\$ 3,960,107	\$ 10,840,266
MSF	65%	\$ 4,472,103	\$ 2,574,070	\$ 7,046,173

EXHIBIT A: TIF TABLE

Estimated Capacity  
Administrative Fees \$ 373,411  
State Reimbursement \$ 20,287  
Local Reimbursement \$ 3,242,557

Estimated Total Years of Plan 17

	2021	2022	2023	2024	2025	2026	2027	2028	2029	2030	2031	2032	2033	2034	2035	2036	2037	2038	2039	2040	Total
Total State Incremental Revenue	\$ 110,134	\$ 112,446	\$ 114,760	\$ 117,074	\$ 119,388	\$ 121,702	\$ 124,016	\$ 126,330	\$ 128,644	\$ 130,958	\$ 133,272	\$ 135,586	\$ 137,900	\$ 140,214	\$ 142,528	\$ 144,842	\$ 147,156	\$ 149,470	\$ 151,784	\$ 154,098	\$ 1,600,107
State Reimbursement (15% of NET)	\$ 16,520	\$ 16,867	\$ 17,214	\$ 17,561	\$ 17,908	\$ 18,255	\$ 18,602	\$ 18,949	\$ 19,296	\$ 19,643	\$ 19,990	\$ 20,337	\$ 20,684	\$ 21,031	\$ 21,378	\$ 21,725	\$ 22,072	\$ 22,419	\$ 22,766	\$ 23,113	\$ 240,214
State TIF Available for Administration	\$ 93,614	\$ 95,579	\$ 97,546	\$ 99,513	\$ 101,480	\$ 103,447	\$ 105,414	\$ 107,381	\$ 109,348	\$ 111,315	\$ 113,282	\$ 115,249	\$ 117,216	\$ 119,183	\$ 121,150	\$ 123,117	\$ 125,084	\$ 127,051	\$ 129,018	\$ 130,985	\$ 1,359,893
Total Local Incremental Revenue	\$ 100,413	\$ 102,579	\$ 104,745	\$ 106,911	\$ 109,077	\$ 111,243	\$ 113,409	\$ 115,575	\$ 117,741	\$ 119,907	\$ 122,073	\$ 124,239	\$ 126,405	\$ 128,571	\$ 130,737	\$ 132,903	\$ 135,069	\$ 137,235	\$ 139,401	\$ 141,567	\$ 1,460,052
MSA Administration Fee (15% of Net State TIF)	\$ 13,928	\$ 14,288	\$ 14,648	\$ 15,008	\$ 15,368	\$ 15,728	\$ 16,088	\$ 16,448	\$ 16,808	\$ 17,168	\$ 17,528	\$ 17,888	\$ 18,248	\$ 18,608	\$ 18,968	\$ 19,328	\$ 19,688	\$ 20,048	\$ 20,408	\$ 20,768	\$ 216,000
Local TIF Available for Administration	\$ 86,485	\$ 88,291	\$ 90,097	\$ 91,903	\$ 93,709	\$ 95,515	\$ 97,321	\$ 99,127	\$ 100,933	\$ 102,739	\$ 104,545	\$ 106,351	\$ 108,157	\$ 109,963	\$ 111,769	\$ 113,575	\$ 115,381	\$ 117,187	\$ 118,993	\$ 120,799	\$ 1,244,052
Developer Maximum Reimbursement	\$ 1,000,000	\$ 1,000,000	\$ 1,000,000	\$ 1,000,000	\$ 1,000,000	\$ 1,000,000	\$ 1,000,000	\$ 1,000,000	\$ 1,000,000	\$ 1,000,000	\$ 1,000,000	\$ 1,000,000	\$ 1,000,000	\$ 1,000,000	\$ 1,000,000	\$ 1,000,000	\$ 1,000,000	\$ 1,000,000	\$ 1,000,000	\$ 1,000,000	\$ 1,000,000
Local-Only Taxes	\$ 3,960,107	\$ 3,960,107	\$ 3,960,107	\$ 3,960,107	\$ 3,960,107	\$ 3,960,107	\$ 3,960,107	\$ 3,960,107	\$ 3,960,107	\$ 3,960,107	\$ 3,960,107	\$ 3,960,107	\$ 3,960,107	\$ 3,960,107	\$ 3,960,107	\$ 3,960,107	\$ 3,960,107	\$ 3,960,107	\$ 3,960,107	\$ 3,960,107	\$ 3,960,107
Local Tax Reimbursement	\$ 2,920,052	\$ 2,920,052	\$ 2,920,052	\$ 2,920,052	\$ 2,920,052	\$ 2,920,052	\$ 2,920,052	\$ 2,920,052	\$ 2,920,052	\$ 2,920,052	\$ 2,920,052	\$ 2,920,052	\$ 2,920,052	\$ 2,920,052	\$ 2,920,052	\$ 2,920,052	\$ 2,920,052	\$ 2,920,052	\$ 2,920,052	\$ 2,920,052	\$ 2,920,052
Total Local TIF Available	\$ 6,880,159	\$ 6,880,159	\$ 6,880,159	\$ 6,880,159	\$ 6,880,159	\$ 6,880,159	\$ 6,880,159	\$ 6,880,159	\$ 6,880,159	\$ 6,880,159	\$ 6,880,159	\$ 6,880,159	\$ 6,880,159	\$ 6,880,159	\$ 6,880,159	\$ 6,880,159	\$ 6,880,159	\$ 6,880,159	\$ 6,880,159	\$ 6,880,159	\$ 6,880,159
Developer Maximum Reimbursement	\$ 3,960,107	\$ 3,960,107	\$ 3,960,107	\$ 3,960,107	\$ 3,960,107	\$ 3,960,107	\$ 3,960,107	\$ 3,960,107	\$ 3,960,107	\$ 3,960,107	\$ 3,960,107	\$ 3,960,107	\$ 3,960,107	\$ 3,960,107	\$ 3,960,107	\$ 3,960,107	\$ 3,960,107	\$ 3,960,107	\$ 3,960,107	\$ 3,960,107	\$ 3,960,107
Local Tax Reimbursement	\$ 2,920,052	\$ 2,920,052	\$ 2,920,052	\$ 2,920,052	\$ 2,920,052	\$ 2,920,052	\$ 2,920,052	\$ 2,920,052	\$ 2,920,052	\$ 2,920,052	\$ 2,920,052	\$ 2,920,052	\$ 2,920,052	\$ 2,920,052	\$ 2,920,052	\$ 2,920,052	\$ 2,920,052	\$ 2,920,052	\$ 2,920,052	\$ 2,920,052	\$ 2,920,052
Total Local TIF Available	\$ 6,880,159	\$ 6,880,159	\$ 6,880,159	\$ 6,880,159	\$ 6,880,159	\$ 6,880,159	\$ 6,880,159	\$ 6,880,159	\$ 6,880,159	\$ 6,880,159	\$ 6,880,159	\$ 6,880,159	\$ 6,880,159	\$ 6,880,159	\$ 6,880,159	\$ 6,880,159	\$ 6,880,159	\$ 6,880,159	\$ 6,880,159	\$ 6,880,159	\$ 6,880,159
Developer Maximum Reimbursement	\$ 3,960,107	\$ 3,960,107	\$ 3,960,107	\$ 3,960,107	\$ 3,960,107	\$ 3,960,107	\$ 3,960,107	\$ 3,960,107	\$ 3,960,107	\$ 3,960,107	\$ 3,960,107	\$ 3,960,107	\$ 3,960,107	\$ 3,960,107	\$ 3,960,107	\$ 3,960,107	\$ 3,960,107	\$ 3,960,107	\$ 3,960,107	\$ 3,960,107	\$ 3,960,107
Local Tax Reimbursement	\$ 2,920,052	\$ 2,920,052	\$ 2,920,052	\$ 2,920,052	\$ 2,920,052	\$ 2,920,052	\$ 2,920,052	\$ 2,920,052	\$ 2,920,052	\$ 2,920,052	\$ 2,920,052	\$ 2,920,052	\$ 2,920,052	\$ 2,920,052	\$ 2,920,052	\$ 2,920,052	\$ 2,920,052	\$ 2,920,052	\$ 2,920,052	\$ 2,920,052	\$ 2,920,052
Total Local TIF Available	\$ 6,880,159	\$ 6,880,159	\$ 6,880,159	\$ 6,880,159	\$ 6,880,159	\$ 6,880,159	\$ 6,880,159	\$ 6,880,159	\$ 6,880,159	\$ 6,880,159	\$ 6,880,159	\$ 6,880,159	\$ 6,880,159	\$ 6,880,159	\$ 6,880,159	\$ 6,880,159	\$ 6,880,159	\$ 6,880,159	\$ 6,880,159	\$ 6,880,159	\$ 6,880,159

LOCAL UNRECORDED REVENUE FUND  
Developer Maximum Reimbursement \$ 3,960,107  
Local Tax Reimbursement \$ 2,920,052  
Total Local TIF Available \$ 6,880,159  
Developer Maximum Reimbursement \$ 3,960,107  
Local Tax Reimbursement \$ 2,920,052  
Total Local TIF Available \$ 6,880,159

\* Up to the year of capture for OER (Developer) after regular income tax reimbursement. May be taken from OER or Local TIF only.

REMARKS:

TIFs administered per a 15% with a \$100,000 cap. This amount may be adjusted downward or upward based upon a plan's proportionate share of all tax increment revenue available and based upon maximum amounts that an authority can capture for administrative fees per PA 381.



**Tax Incremental Revenue Reimbursement Allocation Table**  
**Former DuPont Facility Redevelopment**  
**James P. Cole Blvd, Flint, Genesee County, Michigan**  
**October 31, 2020**

FINAL DRAFT FOR REVIEW AND APPROVAL

**COMMIT A: THE TABLE**

	18	19	20	21	22	23	24	25	26	27	28	29	30	TOTAL
	2018	2019	2020	2021	2022	2023	2024	2025	2026	2027	2028	2029	2030	TOTAL
Total State Incremental Revenue	\$ 130,818	\$ 132,736	\$ 131,685	\$ 134,608	\$ 137,534	\$ 140,460	\$ 143,386	\$ 146,312	\$ 149,238	\$ 152,164	\$ 155,090	\$ 158,016	\$ 160,942	\$ 1,641,891
Less: State Tax Credits	\$ 15,152	\$ 15,617	\$ 16,081	\$ 16,546	\$ 17,011	\$ 17,476	\$ 17,941	\$ 18,406	\$ 18,871	\$ 19,336	\$ 19,801	\$ 20,266	\$ 20,731	\$ 207,867
State Tax Available for Reimbursement	\$ 115,666	\$ 117,119	\$ 115,604	\$ 118,062	\$ 120,523	\$ 122,984	\$ 125,445	\$ 127,906	\$ 130,367	\$ 132,828	\$ 135,289	\$ 137,750	\$ 140,211	\$ 1,434,024
Total Local Incremental Revenue	\$ 225,849	\$ 227,868	\$ 226,817	\$ 232,487	\$ 239,361	\$ 246,235	\$ 253,109	\$ 260,983	\$ 268,857	\$ 276,731	\$ 284,605	\$ 292,479	\$ 300,353	\$ 3,054,487
Less: Administrative Fees (15%)	\$ 33,877	\$ 34,180	\$ 34,512	\$ 35,070	\$ 35,701	\$ 36,332	\$ 36,963	\$ 37,594	\$ 38,225	\$ 38,856	\$ 39,487	\$ 40,118	\$ 40,749	\$ 401,292
Local Tax Available for Reimbursement	\$ 191,972	\$ 193,688	\$ 192,305	\$ 197,417	\$ 203,660	\$ 209,903	\$ 216,146	\$ 222,389	\$ 228,632	\$ 234,875	\$ 241,118	\$ 247,361	\$ 253,604	\$ 2,653,195
Total Available for Reimbursement	\$ 307,638	\$ 310,807	\$ 307,909	\$ 315,479	\$ 324,183	\$ 332,887	\$ 341,591	\$ 350,295	\$ 358,999	\$ 367,703	\$ 376,407	\$ 385,111	\$ 393,815	\$ 3,975,219
Developer's Contribution	\$ 307,638	\$ 310,807	\$ 307,909	\$ 315,479	\$ 324,183	\$ 332,887	\$ 341,591	\$ 350,295	\$ 358,999	\$ 367,703	\$ 376,407	\$ 385,111	\$ 393,815	\$ 3,975,219
Local Government's Contribution	\$ -	\$ -	\$ -	\$ -	\$ -	\$ -	\$ -	\$ -	\$ -	\$ -	\$ -	\$ -	\$ -	\$ -
Total Developer's Contribution	\$ 307,638	\$ 310,807	\$ 307,909	\$ 315,479	\$ 324,183	\$ 332,887	\$ 341,591	\$ 350,295	\$ 358,999	\$ 367,703	\$ 376,407	\$ 385,111	\$ 393,815	\$ 3,975,219
Total Local Government's Contribution	\$ -	\$ -	\$ -	\$ -	\$ -	\$ -	\$ -	\$ -	\$ -	\$ -	\$ -	\$ -	\$ -	\$ -
Total Available for Reimbursement	\$ 307,638	\$ 310,807	\$ 307,909	\$ 315,479	\$ 324,183	\$ 332,887	\$ 341,591	\$ 350,295	\$ 358,999	\$ 367,703	\$ 376,407	\$ 385,111	\$ 393,815	\$ 3,975,219
Local Government's Contribution	\$ -	\$ -	\$ -	\$ -	\$ -	\$ -	\$ -	\$ -	\$ -	\$ -	\$ -	\$ -	\$ -	\$ -
Total Available for Reimbursement	\$ 307,638	\$ 310,807	\$ 307,909	\$ 315,479	\$ 324,183	\$ 332,887	\$ 341,591	\$ 350,295	\$ 358,999	\$ 367,703	\$ 376,407	\$ 385,111	\$ 393,815	\$ 3,975,219
Local Government's Contribution	\$ -	\$ -	\$ -	\$ -	\$ -	\$ -	\$ -	\$ -	\$ -	\$ -	\$ -	\$ -	\$ -	\$ -
Total Available for Reimbursement	\$ 307,638	\$ 310,807	\$ 307,909	\$ 315,479	\$ 324,183	\$ 332,887	\$ 341,591	\$ 350,295	\$ 358,999	\$ 367,703	\$ 376,407	\$ 385,111	\$ 393,815	\$ 3,975,219
Local Government's Contribution	\$ -	\$ -	\$ -	\$ -	\$ -	\$ -	\$ -	\$ -	\$ -	\$ -	\$ -	\$ -	\$ -	\$ -
Total Available for Reimbursement	\$ 307,638	\$ 310,807	\$ 307,909	\$ 315,479	\$ 324,183	\$ 332,887	\$ 341,591	\$ 350,295	\$ 358,999	\$ 367,703	\$ 376,407	\$ 385,111	\$ 393,815	\$ 3,975,219
Local Government's Contribution	\$ -	\$ -	\$ -	\$ -	\$ -	\$ -	\$ -	\$ -	\$ -	\$ -	\$ -	\$ -	\$ -	\$ -

Up to five years of capacity for LEAF deposits shall be  
 15% administrative fee to LEAF, with a \$100,000 cap. The  
 shall's proportional share of all tax increment revenue  
 for administrative fees per FA 362.

Exhibit A  
PROPOSED DUPONT INDUSTRIAL FACILITY  
Brownfield Redevelopment Plan

**ATTACHMENT G**

**Environmental Department Acknowledgement and Other Environmental  
Documents**



RICK SNYDER  
GOVERNOR

STATE OF MICHIGAN  
DEPARTMENT OF ENVIRONMENTAL QUALITY  
LANSING DISTRICT OFFICE



C. HEIDI GREYER  
DIRECTOR

September 17, 2018

**ACKNOWLEDGEMENT OF RECEIPT OF A BASELINE ENVIRONMENTAL  
ASSESSMENT**

**BEA ID:** B201802506LA

**Legal Entity:** James P Cole Venture LLC, 27 Forest Lane, South Barrington,  
Illinois 60010

**Property Address:** 1809 James P Cole Boulevard, Flint, Genesee County, Michigan

On September 13, 2018, the Michigan Department of Environmental Quality (MDEQ) received a Baseline Environmental Assessment (BEA) dated September 10, 2018, for the above legal entity and property. This letter is your acknowledgement that the MDEQ has received and recorded the BEA. The MDEQ maintains an administrative record of each BEA as received.

This BEA was submitted pursuant to Section 20126(1)(c) of Part 201, Environmental Remediation, and/or Section 21323a(1)(b) of Part 213, Leaking Underground Storage Tanks, of the Natural Resources and Environmental Protection Act, 1994 PA 451, as amended (NREPA). A BEA is submitted for the purpose of establishing an exemption to liability for a new owner or operator of property that has been demonstrated to be a facility or property as defined by Section 20101(1)(s) of Part 201, Environmental Remediation, and/or property as defined by Section 21303(d) of Part 213, Leaking Underground Storage Tanks, of the NREPA. Pursuant to Sections 20126(1)(c) and 21323a(1)(b), the conditions of this exemption require the legal entity to disclose the BEA to a subsequent purchaser or transferee of the property.

The BEA is only for the legal entity and property identified in the BEA and on the BEA Submittal Form. Each new legal entity that becomes the owner or operator of this facility must submit their own BEA.

The MDEQ is not making any findings about the adequacy of the submittal or whether the submitter is liable or is eligible to submit. The submitted BEA does not alter liability with regard to a subsequent release, threat of release, or exacerbation of existing conditions that is the responsibility of the legal entity submitting the BEA.

The legal entity, as the owner and/or operator of a facility or property, may have Due Care responsibilities under Section 20107a of Part 201, Environmental Remediation, and/or Section 21304c of Part 213, Leaking Underground Storage Tanks, of the NREPA.

The legal entity may also have responsibility under applicable state and federal laws, including, but not limited to, Part 201, Environmental Remediation; Part 111, Hazardous Waste Management; Part 211, Underground Storage Tank Regulations; Part 213, Leaking Underground Storage Tanks; Part 615, Supervisor of Wells, of the NREPA; and the Michigan Fire Prevention Code, 1941 PA 207, as amended.

Pursuant to Section 20112a(6) of Part 201, Environmental Remediation, the property(s) identified in the BEA will be placed on the inventory of facilities, which is updated daily and posted on the MDEQ's website: <https://secure1.state.mi.us/FacilitiesInventoryQueries>.

Authorized signature:

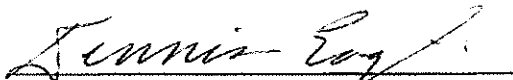

Dennis Eagle, District Supervisor  
Lansing District Office  
Remediation and Redevelopment Division  
Michigan Department of Environmental Quality  
525 West Allegan Street  
P.O. Box 30242  
Lansing, Michigan 48909  
517-614-8544  
[eagled@michigan.gov](mailto:eagled@michigan.gov)

Enclosure

cc: Environmental Consulting & Technology Inc.



MICHIGAN DEPARTMENT OF ENVIRONMENTAL QUALITY – REMEDIATION AND REDEVELOPMENT DIVISION, PO BOX 30426, LANSING, MICHIGAN 48909-7926, Phone 517-373-9837, Fax 517-373-2637

FOR DEQ USE ONLY  
BEA SUBMITTAL #  
PA201802500LA

**Baseline Environmental Assessment Submittal Form**

*This form is for submittal of a Baseline Environmental Assessment (BEA), as defined by Part 201, Environmental Remediation and Part 213, Leaking Underground Storage Tanks, of the Natural Resources and Environmental Protection Act, 1994 PA 451, as amended, for the purpose of establishing an exemption to liability pursuant to Section 20126(1)(c) and Section 21323a(1)(b) for a new owner or operator of property that is a facility as defined by Section 20101(1)(s) or Property as defined by Section 21303(d). The BEA report must be conducted either prior to or within 45 days after becoming the owner or operator, whichever is earliest. This form and the BEA report must be submitted prior to or within 6 months of becoming the owner or operator whichever is earliest. A separate BEA is required for each legal entity that is or will be a new owner or operator of the property. To maintain the exemption to liability, the owner and operator must also disclose the BEA to any subsequent purchaser or transferee before conveying interest in the property pursuant to Section 20126(1)(c) and Section 21323a(1)(b). An owner or operator of a facility or Property also has due care obligations under Section 20107a and Section 21304c with respect to any existing contamination to prevent unacceptable exposure; prevent exacerbation; take reasonable precautions; provide reasonable cooperation, assistance, and access to authorized persons taking response activities at the property; comply with land use restrictions associated with response activities; and not impede the effectiveness of response activities implemented at the property. Documentation of due care evaluations, all conducted response activities, and compliance with 7a or 4c need to be available to the MDEQ, but not submitted, within 8 months of becoming the owner or operator of a facility and/or Property.*

**Section A: Legal Entity Information**

Name of legal entity that does or will own or operate the property: <b>James P Cole Venture, LLC</b>  Address: <b>27 Forest Lane</b> City: <b>South Barrington</b> State: <b>IL</b> ZIP: <b>60010</b>  Contact Person (Name & Title): <b>Ms. Ramona Navitsky - Treasurer</b> Telephone: <b>(312) 543-1250</b> Email: <b>mona.navitsky@dearcapcre.com</b>	Contact for BEA questions if different from submitter: Name & Title: <b>Mr. John D'Addona - Principal Engineer</b>  Company: <b>Environmental Consulting &amp; Technology, Inc.</b>  Address: <b>2200 Commonwealth Blvd., Suite 300</b>  City: <b>Ann Arbor</b> State: <b>MI</b> ZIP: <b>48105</b>  Telephone: <b>(734) 769-3004</b> Email: <b>jdaddona@ectinc.com</b>
---	---

**Section B: Property Information**

Street Address of Property: <b>1809 James P Cole Blvd</b> City: <b>Flint</b> State: <b>MI</b> Zip: <b>48503</b> City/Village/Township: <b>City of Flint</b>  Property Tax ID (include all applicable IDs): <b>41-06-452-014 &amp; 41-06-452-015</b>  Address according to tax records, if different than above (include all applicable addresses):  City: _____ State: _____ Zip: _____  Status of submitter relative to the property (check all that apply): <table style="width:100%; border:none;"> <tr> <td style="text-align:center;">Former</td> <td style="text-align:center;">Current</td> <td style="text-align:center;">Prospective</td> </tr> <tr> <td>Owner <input type="checkbox"/></td> <td><input type="checkbox"/></td> <td><input checked="" type="checkbox"/></td> </tr> <tr> <td>Operator <input type="checkbox"/></td> <td><input type="checkbox"/></td> <td><input checked="" type="checkbox"/></td> </tr> </table>	Former	Current	Prospective	Owner <input type="checkbox"/>	<input type="checkbox"/>	<input checked="" type="checkbox"/>	Operator <input type="checkbox"/>	<input type="checkbox"/>	<input checked="" type="checkbox"/>	County: <b>Genesee</b>  Town: <b>7 North</b> Range: <b>7 East</b> Section: <b>6 and 7</b> Quarter: _____ Quarter-Quarter: _____  Decimal Degrees Latitude: <b>43.0324828</b> Decimal Degrees Longitude: <b>83.684671</b>  Reference point for latitude and longitude: Center of site <input checked="" type="checkbox"/> Main/front door <input type="checkbox"/> Front gate/main entrance <input type="checkbox"/> Other <input type="checkbox"/>  Collection method: Survey <input type="checkbox"/> GPS <input checked="" type="checkbox"/> Interpolation
Former	Current	Prospective								
Owner <input type="checkbox"/>	<input type="checkbox"/>	<input checked="" type="checkbox"/>								
Operator <input type="checkbox"/>	<input type="checkbox"/>	<input checked="" type="checkbox"/>								

**Section C: Source of contamination at the property (check all that are known to apply):**

Facility regulated pursuant to Part 201, other source, or source unknown Part 201 Site ID, if known: _____ <input type="checkbox"/>  Property - Leaking Underground Storage Tank regulated pursuant to Part 213 Part 211/213 Facility ID, if known: _____ <input type="checkbox"/>  Oil or gas production and development regulated pursuant to Part 615 or 625 <input type="checkbox"/> Licensed landfill regulated pursuant to Part 115 <input type="checkbox"/> Licensed hazardous waste treatment, storage, or disposal facility regulated pursuant to Part 111 <input type="checkbox"/>	<b>RECEIVED</b>  <b>SEP 13 2018</b>  <b>MDEQ - RRD</b> <b>LANSING DISTRICT OFFICE</b>
--	--

**Section D: Applicable Dates (provide date for all that are relevant):**

Date All Appropriate Inquiry (AAI) Report or Phase I Environmental Assessment Report completed:	MM/DD/YYYY 07/11/2018
Date Baseline Environmental Assessment Report conducted:	09/10/2018
Date submitter first became the owner:	09/14/2018

Date submitter first became the operator:	09/14/2018
Date submitter first became the operator (if prior to ownership):	N/A
Anticipated date of becoming the owner for prospective owners:	N/A
Anticipated date of becoming the operator for prospective operators:	N/A
If former owner or operator of this property, prior dates of being the owner or operator.	N/A

**Section E: Check the appropriate response to each of the following questions:**

	YES	NO
1 Is the property at which the BEA was conducted a "facility" as defined by Section 20101(1)(s) or a Property as defined by Section 21303(d)?	<input checked="" type="checkbox"/>	<input type="checkbox"/>
2 Was the All Appropriate Inquiry (AAI) completed in accordance with Section 20101(1)(f) and or 21302(1)(b)?	<input checked="" type="checkbox"/>	<input type="checkbox"/>
3 Was the BEA, including the sampling, conducted either prior to or within 45 days of the date of becoming the owner, operator, or of foreclosure, whichever is earliest?	<input checked="" type="checkbox"/>	<input type="checkbox"/>
4 Is this BEA being submitted to the department within 6 months of the submitter first becoming the owner or operator, or foreclosing?	<input checked="" type="checkbox"/>	<input type="checkbox"/>
5 Does the BEA provide sufficient rationale to demonstrate that the data is reliable and relevant to define conditions at the property at the time of purchase, occupancy, or foreclosure, even if the BEA relies on studies of data prepared by others or conducted for other purposes?	<input checked="" type="checkbox"/>	<input type="checkbox"/>
6 Does this BEA contain the legal description of the property addressed by the BEA?	<input checked="" type="checkbox"/>	<input type="checkbox"/>
7 Does this BEA contain the environmental analytical results, a scaled map showing the sample locations, and the basis for the determination that the property is a facility as defined by Section 20101(1)(s) or the basis for the determination that the property is a Property as defined by Section 21303(d)?	<input checked="" type="checkbox"/>	<input type="checkbox"/>

**Section F: Environmental Consultant Signature:**

*I certify to the best of my knowledge and belief, that this BEA and all related materials are true, accurate, and complete. I certify that the property is a facility as defined by Section 20101(1)(s) or a Property as defined by Section 21303(d) and have provided the sampling and analyses that support that determination. I certify that any exceptions to, or deletions from, the All Appropriate Inquiry Rule are described in Section 1 of the BEA report.*

Signature: John D'Addona, P.E. Date: September 10, 2018

Printed Name: **John D'Addona, P.E.**

Company: **Environmental Consulting & Technology, Inc.**

Mailing Address: **2200 Commonwealth, Suite 300** City: **Ann Arbor** State: **MI** Zip: **48105**

Telephone: **(734) 769-3004**

E-Mail: **jdaddona@ectinc.com**

**Section G: Legal Entity Signature:**

*With my signature below, I certify that to the best of my knowledge and belief, this BEA and all related materials are true, accurate, and complete.*

Signature: Ramona Navitsky Date: September 7, 2018

*(Person legally authorized to bind the legal entity)*

Printed Name: **Ms. Ramona Navitsky**

Title and Relationship of signatory to submitter: **Treasurer**

Address: **27 Forest Lane**

City: **South Barrington**

State: **IL**

Zip: **60010**

Telephone: **(312) 543-1250**

E-Mail: **mona.navitsky@dearcapcre.com**

Submit the BEA report and this form to the MDEQ District Office for the county in which the property is located. An office map is located at [www.michigan.gov/deqrrd](http://www.michigan.gov/deqrrd).



*2200 Commonwealth Blvd., Suite 300, Ann Arbor, Michigan 48105*

## **BASELINE ENVIRONMENTAL ASSESSMENT**

**Parcels 41-06-452-014 & 41-06-452-015  
JAMES P. COLE BOULEVARD  
FLINT, MICHIGAN 48503**

**For submission to:**  
Michigan Department of Environmental Quality  
Remediation and Redevelopment Division  
Lansing District Office  
525 West Allegan Street  
P.O. Box 30242  
Lansing, Michigan 48909

**September 10, 2018**

ECT No. 180509-0190

*Complex Challenges . . . PRACTICAL SOLUTIONS*

---

## Document Review

---

The dual signatory process is an integral part of Environmental Consulting & Technology, Inc.'s (ECT's) Document Review Policy No. 9.03. All ECT documents undergo technical/peer review prior to dispatching these documents to any outside entity.

This document has been authored and reviewed by the following employees:

Ryan Higuchi  
Author

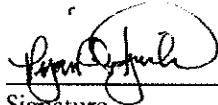
  
Signature

September 10, 2018  
Date

John D'Addona, P.E.  
Peer Review

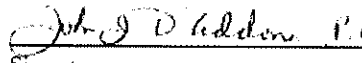
  
Signature

September 10, 2018  
Date



# Table of Contents

---

<u>Section</u>	<u>Page</u>
1.0 Introduction and Discussion	1-1
1.1 Owner/Operator Information	1-1
1.2 Intended Use of Property	1-1
1.3 Executive Summary of AAI	1-1
1.4 Exceptions or Deletions from AAI Rule	1-3
1.5 Discussion of Data Gaps	1-3
1.6 Previous Baseline Environmental Assessments	1-3
1.7 Discussion of Environmental Sampling	1-4
1.7.1 Soil Sampling	1-5
1.7.2 Groundwater Sampling	1-5
1.7.3 Location of Known Contamination	1-6
1.7.4 Basis for Concluding Facility Status	1-8
2.0 Property Information	2-9
2.1 Legal Description	2-9
2.2 Property Boundaries	2-10
2.3 Site Map	2-10
2.4 Subject Property Location	2-10
2.5 Spatial Data	2-10
3.0 Facility Status	3-11
3.1 Known Contamination	3-11
3.2 Laboratory Data	3-11
4.0 BEA Author	4-12
5.0 ASTM Phase I ESA and AAI Documentation	5-13
6.0 References	6-14

**TABLES**

- Table 1 – Soil Analytical Summary
- Table 2 – Groundwater Analytical Summary

**FIGURES**

- Figure 1 – Subject Property Location
- Figure 2 – Site and Surrounding Properties Map
- Figure 3 – Sample Location Map

**APPENDICES**

- Appendix A—Phase I Environmental Site Assessment, AKT Pecrless, July 11, 2018
- Appendix B—Soil Boring Logs
- Appendix C—Laboratory Testing Results
- Appendix D—Baseline Environmental Assessment, AMEC, February 2013  
Baseline Environmental Assessment, Applied Science, Inc.,  
September 2016

## List of Acronyms

AAI	All Appropriate Inquiry
AKT	AKT-Peerless
AMEC	AMEC Environment & Infrastructure, Inc.
AST	Aboveground Storage Tank
ASTM	American Society for Testing and Materials
BEA	Baseline Environmental Assessment
BGS	Below Ground Surface
CAS	Chemical Abstract Service Number
CERCLA	Comprehensive Environmental Response, Compensation, and Liability Act
CERCLIS	Comprehensive Environmental Response, Compensation, and Liability Information System
COC	Chain of Custody
CREC	Controlled Recognized Environmental Condition
DC	Direct Contact
ECT	Environmental Consulting & Technology, Inc.
EDR	Environmental Data Resources, Inc.
EP	Environmental Professional
EPA	Environmental Protection Agency
ESA	Environmental Site Assessment
FINDS	Facility Index System/Facility Registry System
GRCC	Generic Residential Cleanup Criteria
GSI	Groundwater Surface Water Interface
HREC	Historical Recognized Environmental Condition
JPCV	James P. Cole Ventures, LLC
MDEQ	Michigan Department of Environmental Quality
NonGen	Non-generator
NREPA	Natural Resources and Environmental Protection Act
LUST	Leaking Underground Storage Tank
PCB	Polychlorinated biphenyls
PNA	Polynuclear aromatics
PID	Photoionization Detector
PPM	Parts per Million
RCRA	Resource Conservation and Recovery Act
REC	Recognized Environmental Condition
SVIAI	Soil Volatilization to Indoor Air Inhalation
SVOC	Semi-volatile Organic Compounds
SWDBG	State-wide Default Background
SWF/LF	Solid Waste Facilities/Landfill
USCS	Unified Soil Classification System
USGS	United States Geological Survey
UST	Underground Storage Tank
VOC	Volatile Organic Compounds
WDS	Waste Data System

## 1.0 Introduction and Discussion

---

This Baseline Environmental Assessment (BEA), as defined by the Environmental Remediation, Part 201 of the Natural Resources and Environmental Protection Act (NREPA), 1994 PA 451, as amended, and the Part 201 Rules promulgated thereunder, has been completed by Environmental Consulting & Technology, Inc. (ECT) on behalf of James P. Cole Venture, LLC (JPCV), for the approximately 17.99-acre property comprised of two (2) parcels of 16.09 acres (Parcel A) located at 1809 James P. Cole Boulevard, and 1.90 acres (Parcel B) located at James P. Cole Boulevard in Flint, Michigan 48503 (herein referred to as the Subject Property). This BEA has been completed pursuant to Section 20126(1)(c) of Part 201 of NREPA PA 451 of 1994, as amended (Part 201).

In conducting this BEA, ECT has considered the results of a historical property use review and a physical reconnaissance performed in general conformance with the scope and limitation of American Society for Testing and Materials (ASTM) Practice E 1527-13. ECT has also obtained and reviewed data from sampling and analytical testing to adequately describe the environmental conditions that exist at the Subject Property at the time of the acquisition by the Submitter.

### 1.1 Owner/Operator Information

The purchaser of the Subject Property and Submitter of this BEA is James P. Cole Venture, LLC.

### 1.2 Intended Use of Property

The Submitter intends to redevelop the Subject Property consistent with local zoning and land-use ordinances. Operations on the Subject Property will not require the use of hazardous substances in a manner that would be considered a significant hazardous substance use as defined in Rule 901(o). This is the basis for being able to distinguish the existing contamination from any future release of a hazardous substance on the Subject Property.

### 1.3 Executive Summary of AAI

On July 11, 2018, AKT-Peerless (AKT), on behalf of JPCV, completed a Phase I ESA in general conformance with the scope and limitations of ASTM Practice E 1527-13 for the Subject Property. The Phase I ESA identified five (5) recognized environmental conditions (RECs) in connection with the Subject Property which are as follows:

**REC 1 -** *"The subject property operated for industrial purposes from 1901 until 1996, specifically as a varnish and spring manufacturer from 1901 until the early 1920s, and then as DuPont from the early 1920s until 1996. Operations on the subject property included the use and/or storage of heavy industrial equipment, various chemicals, various petroleum products, hazardous substances, and/or hazardous wastes.*

*Moreover, the subject property was identified on the Waste Data System (WDS) database, the Resource Conservation & Recovery Act - Corrective Action Facilities (RCRAC) database, the Resource Conservation and Recovery Act - Generator Facilities (RCRAGRO5) database, the Resource Conservation & Recovery Act Sites with Controls (RCRASC) database, the Resource Conservation & Recovery Act - Non-CORRACTS Treatment, Storage & Disposal Facilities (RCRAT)*

database, the Baseline Environmental Assessment (BEA) database, the Biennial Reporting System (BRS) database, the Enforcement and Compliance History Online (ECHO05) database, the Facility Registration System (FRSMI) database, the Institutional and Engineering Controls Registry (IEEC) database, the Inventory of Facilities (IF) database, Registered Underground Storage Tank (RUST), the Registered Aboveground Storage Tank (RAST) database, the Leaking Underground Storage Tank (LUST) database, and the Toxics Release Inventory (TRI) database.

According to the RUST database, seven USTs were removed from the ground. Additionally, MDEQ RRD file documentation confirmed a release (C-0226-89) of an unknown substance on June 5, 1989. The confirmed release was granted "closure" by the MDEQ on October 13, 1998. The results of subsurface investigations conducted between 1989 and 2015 identified soil and groundwater contamination at the subject property. Several compounds including benzene, ethylbenzene, 1,2,4-trimethylbenzene isomers, xylenes, benzo(g,h,i)perylene, fluoranthene, indo(1,2,3-cd)pyrene, arsenic, chromium, cobalt, and cyanide were identified in on-site soil and groundwater samples exceeding the current MDEQ Part 201 residential cleanup criteria (RCC).

Based on laboratory analytical results, the subject property meets the definition of a facility, as defined in Part 201 of the NREPA, Michigan Public Act (P.A) 451, 1994, as amended. A BEA was subsequently disclosed to the MDEQ based upon the facility designation. In AKT Peerless' opinion, the historical use of the subject property and the presence of known contamination at the subject property represent a REC.

Multiple subsurface investigations were conducted on the subject property between 1989 and 2015 to address previously identified environmental concerns. It is AKT Peerless' opinion, the recognized environmental concerns discussed above have been adequately evaluated and no further subsurface investigation activities are recommended at this time. However, as noted previously, the subject property meets the definition of a facility, as defined in Part 201 of the NREPA, Michigan P.A 451, 1994, as amended. Therefore, AKT Peerless recommends any future owner(s)/operator(s) prepare a BEA report and conduct a Section 20107(a) Documentation of Due Care Compliance (DDCC) Analysis prior to future use and occupancy."

**REC 2** - "The northern adjoining property (902 E Hamilton Avenue) historically operated for industrial purposes since at least 1914 until at least 1999. This adjoining property was identified on the Inventory of Facilities (IF) database and the P-ART 201 database. This adjoining property was also identified on the RUST database with 94 USTs, in which 90 have been removed and 4 are currently in use. This adjoining property was identified on the LUST database with 18 releases, of which 12 are currently listed as "open" by the MDEQ. In AKT Peerless' opinion, the known contamination related to the historical uses of the northern adjoining property and the 12 open releases represents a REC."

**REC 3** - "The southwestern adjoining property (1513 St John Street, historically 1517 St John Street) operated as an automotive repair shop since at least 1928 until at least 1967. This adjoining property was identified on the WDS database and the RUST database with one UST, which was removed on January 19, 1999. Additionally, MDEQ RRD file documentation confirmed a release (C-0047-99) of an unknown substance on January 19, 1999. The confirmed release was granted "closure" by the MDEQ on May 16, 1999. In AKT Peerless' opinion, the historical uses of the southwestern adjoining property and historical release represents a REC."

**REC 4** - "The western adjoining property (1620 Industrial Avenue) is currently being utilized for the storage of demolition debris. This adjoining property has historically operated for industrial purposes since at least 1902 until at least 1999. This adjoining property was identified on the IF database, the P-ART 201 database, and the BEA database. Additionally, MDEQ RRD file documentation confirmed a release (C-0146-85) of an unknown substance on June 2, 1987. The confirmed release remains "open" with the MDEQ. In AKT Peerless' opinion, the current use of the western adjoining property, the known contamination related to the historical uses of this adjoining property, and the open release represents a REC."

**REC 5** - "The western adjoining property (1002 E Hamilton Avenue) has historically operated for industrial purposes since at least 1902 until at least 1999. This adjoining property was identified on the IF database with a BEA. In AKT Peerless' opinion, that the known contamination related to the historical uses of this adjoining property represents a REC."

Based on these findings, AKT recommended further site investigation and/or assessment for RECs 2 through 5 in order to evaluate potential contaminant migration onto the Subject Property.

The Phase I ESA also identified a Controlled Recognized Condition (CREC) in connection to the Subject Property pertaining to the following:

**CREC 1** - *"According to information obtained from a review of Michigan Department of Environmental Quality, (MDEQ) file information, a restrictive covenant was set in place for two locations on Parcel A of the Subject Property dated May 29, 2009. The restrictive covenant includes a land use restriction that prohibits the use of the two areas of the subject property that are not in compliance with the limited or site-specific land use category; it also prohibits groundwater use for any purposes, except for wells and devices that are part of an MDEQ-approved response activity. With these considerations, contamination will remain on site at concentrations that exceeds the MDEQ, Part 201/213 (1994 P.A. 451) Residential Risk Based Screening Levels. Consequently, the subject property is a "facility" as that term as defined in Part 201."*

A copy of AKT's Phase I ESA is attached hereto as **Appendix A**.

The Submitter is unaware of any abandoned or discarded containers currently present on the Subject Property. Therefore, form EQP4476 is not required as part of this BEA.

## 1.4 Exceptions or Deletions from AAI Rule

The Phase I ESA included a review of current plat maps, historical plat maps, city directories, aerial photographs, topographic maps, property deeds, tax assessor's records, building permits, environmental reports, historical sources, and personal interviews conducted with individuals and public officials having knowledge of the Subject Property. A systematic review of environmental databases maintained by state and federal government agencies was also performed as required and defined by ASTM Practice E 1527-13. Accordingly, while ECT is unaware of any limitations or exceptions from the standard practice, it recognizes inherent limitations for Phase I ESAs in general, including but not limited to the elimination of uncertainty, non-exhaustive assessment and variable level of inquiry. Readers of this BEA are directed to Section 1.3 of AKT's Phase I ESA for an explanation of these limitations (**Appendix A**).

## 1.5 Discussion of Data Gaps

In accordance with ASTM Practice E 1527-13, the identification of data gaps, as well as comments on their significance on the ability to identify RECs for the Subject Property is required. As stated in Section 9.0 of the Phase I ESA, AKT identified the following deviations or "significant" data gaps, as defined by §312.10 of AAI final rule and §12.7 of ASTM E1527-13 for the Subject Property:

- *"Due to data failure, AKT Peerless was unable to determine the past development or use of the subject property prior to 1898 after review of reasonably ascertainable historical sources. AKT Peerless considers this to be a significant data gap (as defined by ASTM Practice E 1527) which may have impacted AKT Peerless' ability to identify RECs in connection with the subject property."*

## 1.6 Previous Baseline Environmental Assessments

ECT is aware of two (2) previous BEAs that were prepared for the Subject Property. A summary of the data collected in support of these BEAs are as follows:

#### **AMEC Environmental & Infrastructure – February 2013**

A BEA was prepared and filed by AMEC Environment & Infrastructure, Inc. (AMEC) on behalf of the Mullins Land Company, LLC in February 2013. The BEA was completed based on the identification of seven (7) RECs from a prior Phase I ESA dated January 2013 that was completed by AMEC. These RECs included:

- The historical use of the subject property for manufacturing of varnishes, paints, and adhesives,
- The historical environmental database listings,
- The presence of an operating groundwater treatment system designed to recover light non-aqueous phase liquid (LNAPI) and contaminated groundwater,
- The recorded deed restriction,
- The historical presence of a railroad west of the subject property,
- The historical presence of automobile component factories and bulk petroleum storage facilities on the western adjoining property, and
- The historical presence of automobile component factories and documented releases on the northern adjoining properties.

As noted by AMEC, DuPont conducted several remedial investigations at the Subject Property that included the advancement of over 150 soil borings, the excavation of approximately 20 test pits, over 40 groundwater monitoring well installations, and the collection of soil and groundwater samples for laboratory analysis. AMEC compared soil and groundwater results to the MDEQ Part 201 Residential Cleanup Criteria (RCC). Soil and groundwater exceedances of these criteria were primarily located in the vicinity of Building 6 and a former UST area, located at the southeast property boundary. Based on these historical analytical testing results, DuPont reportedly excavated and disposed of all contaminated soil above the saturated zone that exceeded the MDEQ's Part 201 industrial direct contact criteria. A groundwater treatment system was also installed around the exterior of Subject Building 6, and two land and resource use restrictions areas were filed for the Subject Property.

#### **Applied Science, Inc. – September 2016**

A BEA was prepared and filed by Applied Science, Inc. on behalf of C3 PH, LLC in September 2016. Applied Science noted that DuPont entered into a Voluntary Corrective Action agreement with MDEQ that included the excavation of soil impacted above the MDEQ non-residential direct contact cleanup criteria, as well as the operation of a groundwater treatment system designed to remove contaminated groundwater and free product. In 2015, DuPont requested a no further action status with regard to the free product recovery with respect to the absence of free product for a period of 12 consecutive months.

Contamination was still noted on the Subject Property in soil and groundwater above the MDEQ Part 201 Residential Cleanup Criteria (RCC) for VOCs, SVOCs, arsenic, chromium, cobalt, and cyanide, therefore Applied Science concluded that the Subject Property met the definition of a facility as defined in Part 201 of NREPA, Michigan Public Act 451, 1994, as amended.

## **1.7 Discussion of Environmental Sampling**

AKT's Phase I report identifies a recognized environmental condition pertaining to the Subject Property's prior uses which involved use and/or storage of heavy industrial equipment, various chemicals, various petroleum products, hazardous substances, and/or hazardous wastes. A number of investigations between 1989 and 2015 identified soil and groundwater contaminant concentrations that exceeded generic residential cleanup criteria thereby characterizing the Subject Property as a *facility* as defined in Part 201 of NREPA, Michigan Public Act 451, 1994, as amended. Based on the comprehensive sample results, no further subsurface sampling of known on-site contaminant areas were completed for this BEA.

As a result of the findings in the Phase I ESA, ECT performed a Phase II environmental site investigation on August 20, 2018, on behalf of the Submitter for the purpose of evaluating the potential contamination from offsite sources on the Subject Property prior to its acquisition. Specifically, the following evaluation activities were completed:

### 1.7.1 Soil Sampling

Direct push drilling services were performed by Fibertec Environmental Services, Inc. (Fibertec) using a track-mounted Geoprobe® Model 6620 drilling rig. The final depths of the borings were determined in the field based on observed subsurface soil conditions, the potential migration pathways associated with the RECs, and the depth to groundwater. Six (6) soil borings, designated as GP-1 through GP-6, were completed to depths of 15 feet below ground surface (bgs), except at boring GP-6 where the boring was advanced to a depth of 10 feet bgs. Soil characteristics at each boring were described and logged by a field geologist in general accordance with the Unified Soil Classification System (USCS) and screened for ionizable volatile organic compounds (VOCs) using a MiniRae 3000 photoionization detector (PID) equipped with a 10.6 electron volt (eV) lamp. The PID had a minimum detection limit of 0.1 parts per million (ppm) and was calibrated daily prior to usage. The locations of the soil borings are depicted on **Figure 3**.

Soil borings GP-1, GP-2, GP-5, and GP-6 were located in areas where the construction of new buildings is proposed. For each of these locations, one (1) discrete soil sample was collected for laboratory analytical testing. The soil samples were collected within ten feet below the ground surface based on elevated PID screening results. If there were negligible differences in PID screening results through the soil column, a sample was collected based on soil types or visual observations or at the bottom of the 10-foot interval. Soil descriptions, sample collection intervals, and PID readings are shown on the soil boring logs provided in **Appendix B**. Soil samples selected for laboratory analyses were placed in an ice-filled cooler for transportation to Fibertec's analytical laboratory. All four (4) of the soil samples were analyzed for VOCs, polynuclear aromatics (PNAs), and 10-MI metals as described below in Section 1.7.3. The soil sampling locations are shown on **Figure 3**.

### 1.7.2 Groundwater Sampling

Groundwater samples were collected to evaluate the potential for the migration of contamination from an off-site source onto the Subject Property. Shallow groundwater samples were collected from temporary monitoring wells TMW-1 through TMW-6, located at soil borings GP-1 through GP-6, respectively. Groundwater was observed in all six (6) soil borings within the maximum explored depth of 15 feet. Temporary monitoring wells were installed using one-inch disposable polyvinyl chloride (PVC) monitoring wells with 10-slot five-foot screens. The depths of the temporary monitoring wells ranged from 9 to 15 feet bgs, depending on the presence of water-bearing soils observed at the soil boring. Groundwater samples were collected from five of the six temporary monitoring wells. TMW-4, located at GP-4, had insufficient groundwater to produce a groundwater sample. The screened depths of the temporary monitoring wells are included on the soil boring logs provided in **Appendix B**.

Groundwater samples were also collected from existing monitoring wells. Shallow groundwater samples were collected from MW-23S, MW-24S, MW-25S, and MW-26S with depths ranging from 6.6 to 12 feet. Deep groundwater samples were collected from MW-23D, MW-24D, MW-25D, and MW-26D with depths ranging from 68 to 89 feet. Five (5) groundwater samples from temporary monitoring wells (TMW-1, TMW-2, TMW-3, TMW-5, and TMW-6) and three (3) groundwater samples from the existing, deep monitoring wells (MW-23D, MW-24D, and MW-26D) were submitted for analysis for VOCs, PNAs, and 10-MI metals as described below in Section 1.7.3. PCBs were additionally requested for analysis at TMW-1 and MW-24D. Groundwater samples collected for laboratory analyses were placed in an ice-filled cooler for transportation to Fibertec's analytical laboratory. Samples collected from MW-23S, MW-24S, MW-25S, and MW-26S were not submitted for laboratory testing due to the lack of visual and olfactory evidence of contamination. The temporary and existing monitoring well locations are included on **Figure 3**.



### 1.7.3 Location of Known Contamination

#### Soil

A table comparing the results of the soil analytical testing to the current Part 201 Generic Residential Cleanup Criteria (GRCC) is included in **Table 1**. The soil sampling locations are shown on **Figure 3**. The analytical laboratory testing reports are included in **Appendix C**. Based on observed soil conditions and a review of the analytical testing results, ECT concluded the following:

- No VOCs were detected in the four (4) soil samples. The samples were collected to evaluate shallow contamination.
- No PNAs were detected in the four soil samples. The samples were collected to evaluate for shallow contamination.
- Metals were detected above laboratory reporting limits in all soil samples (from soil borings GP-1 through GP-4). The samples were collected to evaluate for shallow contamination in the vicinity of proposed buildings. A concentration of arsenic exceeds the state-wide default background (SWDBG), drinking water protection, groundwater surface water interface (GSI) protection, and residential direct contact. Concentrations of total chromium and selenium exceeds the SWDBG and the GSI protection. The concentration of mercury exceeds the GSI protection criterion, but not the SWDBG. Concentrations of barium, cadmium, copper, lead, silver, and zinc did not exceed their respective SWDBG or criteria. Concentrations of metals that exceed the residential criteria limit are discussed below.
  - Arsenic was detected in every sample at concentrations ranging from 1,400 to 9,900 µg/kg. The concentration of arsenic at GP-2 (3-5') exceeds the SWDBG value (5,800 µg/kg), the DW protection (4,600 µg/kg), the GSI (4,600 µg/kg) protection, and the residential direct contact (7,600 µg/kg) cleanup criteria. Under the Part 201 rules, background values for metals may be substituted for GRCC if the background concentrations are higher than the cleanup criteria. The arsenic concentration is above the SWDBG value, but it is below region-specific background values as presented in the Michigan Department of Environmental Quality (MDEQ) *Michigan Background Soil Survey 2005 (Updated 2015)*. MDEQ has begun accepting these regional soil background values based on the empirical average regional background concentration plus two standard deviations. Therefore, the acceptable background value for arsenic in clay soils within the Erie Glacial Lobe is 31,400 µg/kg. Substituting this value for GRCC results in arsenic concentrations not exceeding GRCC.
  - Chromium was detected in all soil samples at concentrations ranging from 4,000 to 27,000 µg/kg. The concentration of chromium collected from GP-1 (3-5') exceeds the SWDBG (18,000 µg/kg) and GSI protection (3,300 µg/kg) criterion. Due to a higher acute toxicity for hexavalent chromium (Cr(VI)) compared to the more commonly occurring trivalent chromium Cr(III), the Part 201 GRCC for chromium are based on the risks associated with Cr(VI). No Part 201 GRCC are established for Cr(III), but there is a SWDBG level for Cr(III) that is set at 18,000 µg/kg. The laboratory analyses performed for the soil samples represents a total chromium concentration, and does not differentiate between Cr(III) and Cr(VI). Unless additional analyses are performed to specifically test for Cr(VI), the conservative approach is to compare the reported concentrations to the Part 201 Cr(VI) GRCC and the Cr(III) background values.
  - Selenium was detected in two (2) soil samples at concentrations ranging from 240 to 630 µg/kg. The concentration of selenium collected from GP-2 (3-5') exceeds the SWDBG (410 µg/kg) and the GSI protection (400 µg/kg) cleanup criteria. The concentrations of arsenic, chromium, and selenium at GP-1 and GP-2 exceed their respective residential criteria.

### **Groundwater**

A table comparing the results of the groundwater analytical testing to the current Part 201 Generic Residential Cleanup Criteria (GRCC) is included in **Table 2**. The soil sampling locations are shown on **Figure 3**.

The analytical laboratory testing reports are included in **Appendix C**. Based on observed groundwater conditions and a review of the analytical testing results, ECT concluded the following:

- Several VOCs were detected in four groundwater samples: TMW-1, TMW-2, TMW-3, and TMW-5. The samples were collected to evaluate for potential contaminant migration onto the subject property. Benzene was detected in two groundwater samples (TMW-1 and TMW-5) at concentrations ranging from 1.2 to 180 µg/L. The concentrations of benzene at TMW-1 exceed the drinking water protection (5.0 µg/L) and GSI protection (12 µg/L) criteria. Isopropylbenzene was detected in one groundwater sample, TMW-1, at a concentration of 32 µg/L. The concentration of isopropylbenzene exceeds the GSI protection (28 µg/L) criterion. Naphthalene (also discussed under PNAs) was detected in one groundwater sample at a concentration of 39 µg/L. The concentration of naphthalene collected from TMW-1 exceeds the GSI protection (11 µg/L) criterion. Trichloroethene was detected in one groundwater samples at a concentration of 5.3 µg/L. The concentration of trichloroethene collected from TMW-3 exceeds the drinking water protection (5.0 µg/L) criterion. Xylenes were detected in one groundwater sample at a concentration of 60 µg/L. The concentration of xylenes collected from TMW-1 exceeds the GSI protection (41 µg/L) criterion. The concentrations of benzene, isopropylbenzene, naphthalene, trichloroethene, and xylenes in two groundwater samples exceed their respective GRCC. Acetone, sec-butylbenzene, ethylbenzene, n-propylbenzene, toluene, trichlorofluoromethane, 1,2,4-trimethylbenzene (TMB), and 1,3,5-TMB were detected, but the concentrations were below their respective cleanup criteria.
- PNAs were detected in one groundwater sample: TMW-1. Samples were collected to evaluate for potential contaminant migration onto the subject property. Naphthalene (also discussed under VOCs) was detected in one groundwater sample at a concentration of 39 µg/L. The concentration of naphthalene collected from TMW-1 exceeds the GSI protection (11 µg/L) criterion. The concentration of naphthalene in one groundwater sample exceeds the respective residential cleanup criteria. There were no other detections of PNAs.
- Metals were detected above laboratory reporting limits in all groundwater samples, except TMW-1. The samples were collected to evaluate for potential contaminant migration onto the subject property. Concentrations of arsenic, cadmium, and lead exceed the drinking water and GSI criteria. Concentrations of copper exceed the GSI criterion. Concentrations of metals that exceed the residential criteria limit are discussed below.
  - Arsenic was detected in two groundwater samples (TMW-2 and TMW-5) at concentrations ranging from 18 to 25 µg/L. The concentrations exceed the DW (10 µg/L) and the GSI (10 µg/L) criteria.
  - Cadmium was detected in two groundwater samples (MW-23D and MW-26D) at concentrations ranging from 11 to 51 µg/L. The concentrations exceed the DW (5.0 µg/L) and the GSI (2.5 µg/L) criteria.
  - Copper was detected in eight groundwater samples at concentrations ranging from 5.0 to 32 µg/L. The concentrations of copper collected from TMW-2 and TMW-3 exceed the GSI (13 µg/L) criteria.
  - Lead was detected in three groundwater samples at concentrations ranging from 3.0 to 20 µg/L. The concentrations of lead collected from TMW-2 and TMW-3 exceed the DW (4.0 µg/L) and the GSI (14 µg/L) criteria.
  - The concentrations of arsenic, cadmium, copper, and lead exceed their respective residential criteria.

- PCBs were not detected in the two groundwater samples (TMW-1 and MW-24D), which were collected to evaluate for potential contaminant migration onto the Subject Property.

In determining the sample locations and analytical testing parameters described herein, ECT relied upon its best judgment of the hazardous substances most likely to be present with respect to the prior uses of the adjacent properties. Readers should note that the presence of all possible contaminants has neither been confirmed as a part of this assessment, nor is such confirmation a required element of this BEA.

#### **1.7.4 Basis for Concluding Facility Status**

A comparison of analytical data obtained as a result of ECT's August 2018 sampling of areas of the Subject Property potentially affected by the migration of contaminants by off-site sources indicates the presence of VOCs, SVOCs and Michigan 10 Metals within the groundwater, and Michigan 10 Metals at concentrations exceeding levels exceeding the corresponding GRCC established for residential uses under the NREPA, 1994 PA 451, as amended. In addition, contamination remains on the Subject Property in both soil and groundwater above the GRCC for VOCs, SVOCs, arsenic, chromium, cobalt, and cyanide as detailed in the BEA report that was prepared by Applied Science, Inc. in September 2016. Accordingly, the Subject Property described herein meets the definition of a "facility" under Part 201 of the NREPA.

## 2.0 Property Information

### 2.1 Legal Description

The Subject Property is located on the southwest corner of East Hamilton Avenue and James P. Cole Boulevard, north of East Wood Street in the City of Flint. Parcel A is located at 1809 James P. Cole Boulevard while Parcel B has no address number on James P. Cole Boulevard, Sections 6 and 7, Township 7 North, and Range 7 East of the Flint North Quadrangle Map, in Flint, Genesee County, Michigan 48503. The Parcel ID (Tax ID) numbers for the Subject Property are:

Parcel A – (Parcel ID: 41-06-452-014)

THAT PART OF BLKS 29, 30, 31, 32, 33 AND 34 OF OAK PARK SUBDIVISION OF PART OF SECS 1 & 2 OF SMITH'S RESERVATION AND PT OF VACATED ST JOHN ST AND OTHER VACATED STREETS AND PT OF LOTS 1 THRU 15, 19 AND 24 THRU 29 AND INCL ALL OF LOTS 16 THRU 18 AND 20 THRU 23 OF PLAT OF FLANDERS & HOURANS SUBDIVISION AND PT OF THE OLD RR ROW AND OTHER LANDS DESC AS: COM AT THE SW COR OF LOT 25 OF SD PLAT OF FLANDERS & HOURANS SUBDIVISION; TH N 24 DEG 13' 00" E ALG THE ELY ROW LINE OF ST JOHN ST, 211.50 FT; TH N 65 DEG 47' 00" W, 2.35 FT; TH N 64 DEG 31' 55" W, 158.28 FT; TH S 40 DEG 14' 11" E, 1.25 FT; TH N 72 DEG 44' 20" W, 19.17 FT; TH N 17 DEG 08' 12" E, 154.66 FT; TH N 20 DEG 09' 39" E, 288.13 FT; TH N 19 DEG 17' 08" E, 35.22 FT TO POB OF THIS PARCEL OF LAND; TH CONT N 19 DEG 17' 08" E, 101.73 FT; TH N 22 DEG 04' 49" E, 50.04 FT; TH N 23 DEG 58' 29" E, 150.06 FT; TH N 20 DEG 22' 22" E, 110.76 FT; TH N 18 DEG 10' 21" E, 240.78 FT; TH ALG THE ARC OF A CURVE TO THE RIGHT WITH RADIUS OF 1128.83 FT, A DIST OF 144.58 FT, THE LONG CHORD BEARING N 21 DEG 50' 20" E, 144.48 FT; TH N 65 DEG 35' 31" W, 18.63 FT; TH N 14 DEG 02' 16" E, 175.59 FT; TH N 15 DEG 44' 18" E, 271.61 FT; TH N 78 DEG 57' 09" W, 23.05 FT; TH N 11 DEG 47' 00" E, 98.38 FT; TH N 67 DEG 01' 34" W, 0.61 FT; TH N 12 DEG 12' 29" E, 165.28 FT TO A FOUND PT ON THE SLY LINE OF HAMILTON AVE; TH ALG SD HAMILTON AVE AS MONUMENTED, S 89 DEG 06' 53" E, 62.00 FT; TH S 89 DEG 47' 46" E, 33.97 FT TO THE PC OF A NON-TANGENT CURVE TO THE RIGHT, WITH RADIUS OF 597.53 FT; TH ALG THE ARC OF SD CURVE A DIST OF 60.67 FT, THE LONG CHORD BEING S 74 DEG 59' 40" E, 60.64 FT TO THE PC OF A COMPOUND NON-TANGENT CURVE TO THE RIGHT WITH RADIUS OF 45 FT; TH ALG THE ARC OF SD CURVE A DIST OF 31.86 FT, THE LONG CHORD BEING S 51 DEG 48' 10" E, 31.20 FT TO THE PC OF A COMPOUND NON-TANGENT CURVE TO THE RIGHT WITH RADIUS OF 587.53 FT; TH ALG THE ARC OF SD CURVE A DIST OF 75.12 FT, THE LONG CHORD BEING S 64 DEG 34' 42" E 75.07 FT TO THE PT OF SD CURVE; TH S 61 DEG 53' 52" E, 5.55 FT TO THE PC OF A CURVE TO THE RIGHT WITH RADIUS OF 94.30 FT; TH ALG THE ARC OF SD CURVE ENTERING THE WLY ROW LINE OF JAMES P COLE BLVD, A DIST OF 104.95 FT, THE LONG CHORD BEING S 30 DEG 02' 03" E, 99.62 FT TO THE PT OF SD CURVE; TH S 02 DEG 02' 06" W 98.42 FT; TH S 71 DEG 22' 00" E, 1.45 FT; TH S 02 DEG 02' 06" W, 300.76 FT TO THE PC OF A CURVE TO THE RIGHT WITH RADIUS OF 1412.54 FT; TH ALG THE ARC OF SD CURVE A DIST OF 736.52 FT, THE LONG CHORD BEING S 16 DEG 58' 15" W, 728.21 FT TO THE PT OF SD CURVE; TH S 31 DEG 54' 21" W, 302.86 FT TO THE PC OF A CURVE TO THE LEFT, WITH RADIUS OF 1183.35 FT; TH ALG THE ARC OF SD CURVE A DIST OF 563.24 FT, THE LONG CHORD BEING S 18 DEG 16' 15" W, 557.94 FT; TH S 04 DEG 38' 00" W, 197.79 FT TO THE PC OF A CURVE TO THE RIGHT WITH RADIUS OF 15.21 FT; TH ALG THE ARC OF SD CURVE A DIST OF 29.05 FT, THE LONG CHORD BEING S 59 DEG 21' 47" W, 24.83 FT TO THE PT OF SD CURVE; TH N 20 DEG 13' 00" E, 10.01 FT; TH N 66 DEG 59' 02" W, 206.45 FT TO A PT ON A CURVE TO THE RIGHT WITH RADIUS OF 24.68

FT; TH ALG THE ARC OF SD CURVE A DIST OF 18.13 FT, THE LONG CHORD BEING N 03 DEG 10' 06" E, 17.73 FT TO THE PT OF SD CURVE; TH N 24 DEG 13' 00" E, 184.72 FT; TH N 17 DEG 35' 25" E, 447.25 FT; TH N 23 DEG 47' 39" E, 32.57 FT TO A BLDG CORNER; TH N 65 DEG 52' 07" W, ALG A BLDG WALL LINE EXT, 169.12 FT TO THE POB. CONT 15.79 ACRES. SPLIT

Parcel B – (Parcel ID: 41-06-452-015)

THAT PART OF VACATED ST JOHN ST AND OTHER VACATED STREETS, PT OF THE OLD RR ROW AND OTHER LANDS DESC AS: COM AT THE SW COR OF LOT 25 OF PLAT OF FLANDERS & HOURANS SUBDIVISION; TH N 24 DEG 13' 00" E, ALG THE ELY ROW LINE OF ST JOHN ST, 211.50 FT TO THE POB; TH N 65 DEG 47' 00" W, 2.35 FT; TH N 64 DEG 31' 55" W, 158.28 FT; TH S 40 DEG 14' 11" E, 1.25 FT; TH N 72 DEG 44' 20" W, 19.17 FT; TH N 17 DEG 08' 12" E, 154.66 FT; TH N 20 DEG 09' 39" E, 288.13 FT; TH N 19 DEG 17' 08" E, 35.22 FT; TH ALG A BLDG WALL LINE EXT S 65 DEG 52' 07" E, 169.12 FT TO A BLDG CORNER; TH S 23 DEG 47' 39" W, 32.57 FT TO A BLDG CORNER; TH S 17 DEG 35' 25" W, 447.25 FT TO THE POB. CONT 1.90 ACRES. SPLIT ON 12/06/2005 FROM 41-06-452-013; 2003 PARCEL DIVISION OF 11-06-452-011-9

Site photographs of the Subject Property and the surrounding area are presented in Appendix C of AKT's Phase I ESA (**Appendix A**).

## **2.2**      Property Boundaries

The location of the Subject Property is shown on **Figure 1**, Subject Property Location Map and the general layout of the Subject Property is shown on **Figure 2**, Site and Surrounding Properties Map.

## **2.3**      Site Map

A scaled site map, showing sample locations, depths is provided as **Figure 3**.

## **2.4**      Subject Property Location

The Subject Property is comprised of two (2) parcels of land, comprising approximately 17.99-acres (Parcel A 16.09 acres and Parcel B 1.90 acres), and is located on the southwest corner of East Hamilton Avenue and James P. Cole Boulevard, north of East Wood Street in the City of Flint, Michigan, and has the following common address:

1809 James P. Cole Boulevard  
Flint (Genesee County), Michigan 48503

## **2.5**      Spatial Data

The Subject Property is located in Sections 6 and 7, Township 7 North, and Range 7 East of the Flint North Quadrangle Map, in Flint, Genesee County, Michigan. A geographic reference point for the Subject Property (Latitude [North]: 43.0324828 - 43° 1' 56.9382", Longitude [West]: 83.684671 - 83° 41' 4.815") was determined by Geosearch as part of the radial search activities and database review performed in support of AKT's Phase I ESA.

## 3.0 Facility Status

### 3.1 Known Contamination

Listings of the contaminants identified at the Subject Property by ECT in excess of the corresponding analytical reporting limits are provided together with the corresponding Chemical Abstract Service Numbers (CAS #) in **Table 3** below.

**Table 3. Contaminants of Concern**

Contaminants of Concern	CAS Number	Criteria Exceeded
Benzene (groundwater)	71432	DW, NRDW, GSI
Isopropylbenzene (groundwater)	98828	GSI
Naphthalene (groundwater)	91203	GSI
Trichloroethene (groundwater)	79016	DW, NRDW
Xylenes (groundwater)	1330207	GSI
Arsenic (groundwater and soil)	7440382	DW, NRDW, GSI, DC
Cadmium (groundwater)	7440439	DW, NRDW, GSI
Chromium (soil)	18540299	GSI
Copper (groundwater)	7440508	GSI
Lead (groundwater)	7439921	DW, NRDW, GSI
Selenium (soil)	7782492	GSI

DW: Drinking Water Protection, NRDW: Non-Residential Drinking Water, DC: Direct Contact, GSI: Groundwater Surface Water Interface

The listing of these contaminants is in addition to the contaminants previously documented in prior BEAs that were prepared by others for the Subject Property. See **Appendices D and E** for copies of these reports.

### 3.2 Laboratory Data

Copies of the analytical laboratory reports and chain-of-custody (COC) documentation for the samples collected by ECT on August 20, 2018 are included in **Appendix C**.

## 4.0 BEA Author

---

The primary author of this BEA was Ryan P. Higuchi, whose contact information is provided as follows:

Ryan Higuchi  
Senior Associate Scientist III  
Environmental Consulting & Technology, Inc.  
2200 Commonwealth Boulevard, Suite 300  
Ann Arbor, Michigan 48105  
[rhiguchi@ectinc.com](mailto:rhiguchi@ectinc.com)  
Tel. (734) 769-3004

BEA Review and Interpreter of this BEA was John D'Addona, P.E. who is a qualified Environmental Professional (EP) with over 30 years of experience in the environmental industry. His experiences include the management and review of hundreds of Phase I and II ESAs, BEAs, and Due Care Plans. His contact information is as follows:

John D'Addona, P.E.  
Principal Engineer  
Environmental Consulting & Technology, Inc.  
2200 Commonwealth Boulevard, Suite 300  
Ann Arbor, Michigan 48105  
[jdaddona@ectinc.com](mailto:jdaddona@ectinc.com)  
Tel. (734) 769-3004

## 5.0 ASTM Phase I ESA and AAI Documentation

---

A Phase I ESA, completed by AKT, is included as **Appendix A**. The Phase I ESA was completed in general accordance with ASTM Practice E 1527-13. The purpose of ASTM Practice E 1527-13 is to define good commercial and customary practice in the United States of America for conducting an environmental site assessment of commercial real estate properties with respect to the range of contaminants within the scope of the Comprehensive Environmental Response, Compensation and Liability Act (CERCLA; 42 U.S.C. §9601) and petroleum products. The objective of Phase I ESAs is to provide all appropriate inquiries into the previous ownership and uses of the property consistent with good commercial and customary practice as defined at 42 U.S.C. §9601(35)(B) to permit a user to satisfy one of the requirements to qualify for the innocent landowner, contiguous property owner, or bona fide prospective purchaser limitations on CERCLA liability (a.k.a., landowner liability protections). The Phase II ESA investigation was completed in general accordance with ASTM Practice E1903-11, the Standard Practice for Environmental Site Assessments: Phase II Environmental Site Assessment Process.

This BEA has been completed pursuant to Section 20126(I)(c) of Part 201 of the Natural Resources and Environmental Protection Act (NREPA) PA 451 of 1994, as amended (Part 201). In the preparation of this BEA, ECT considered hazardous substances as defined by Section 20101(1)(y) and/or regulated substances as defined by Section 21303(g). This BEA follows the suggested format for the "Contents of BEA Report," presented in EQP 4012 (02/2015).



## **6.0      References**

---

Part 201 of the Natural Resources and Environmental Protection Act, Public Act 451 of 1994, as amended.

ASTM E 1527-13, Standard Practice for Environmental Site Assessments: Phase I Environmental Site Assessment Process.

ASTM Practice E1903-11, Standard Practice for Environmental Site Assessments: Phase II Environmental Site Assessment Process.

Phase I Environmental Site Assessment, Parcels 41-06-452-014 and 41-06-452-015, City of Flint, Michigan prepared by AKT-Peerless, and dated July 11, 2018.

Baseline Environmental Assessment, Former DuPont Automotive Works Site 1555 James P. Cole Boulevard, Flint, Genesee County, Michigan prepared by AMEC Environment and Infrastructure, Inc. and dated January 4, 2013.

Baseline Environmental Assessment, 1555 James P. Cole Boulevard, Flint, Genesee County, Michigan prepared by Antea Group and dated December 7, 2016.

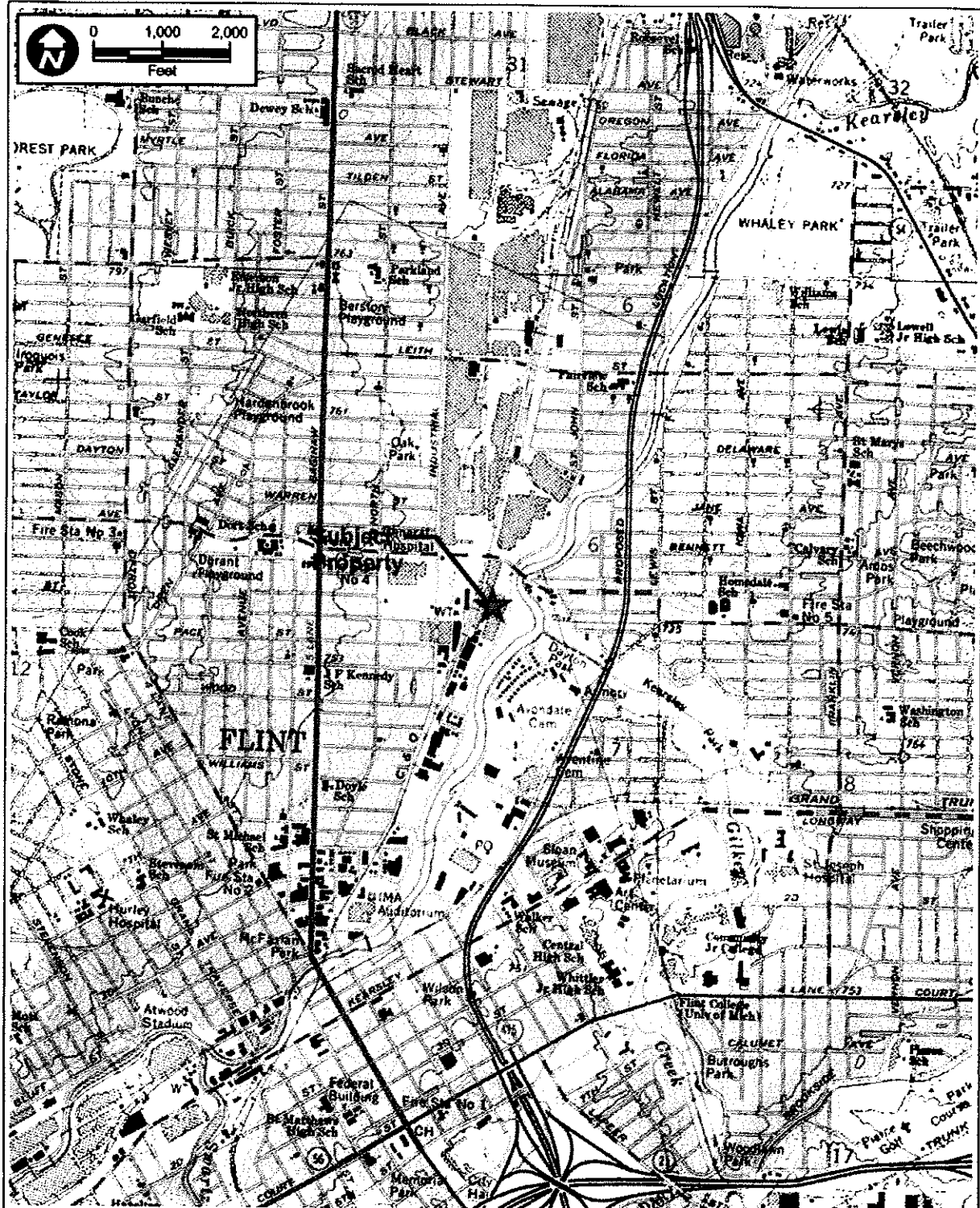

**FIGURE 1.**  
**SITE LOCATION MAP**  
 PARCEL IDs: 41-06-452-014 & 41-06-452-015  
 FLINT, MI. 48503

Sources: ECT, 2016.

**ECT** Environmental  
 Consulting &  
 Technology, Inc.

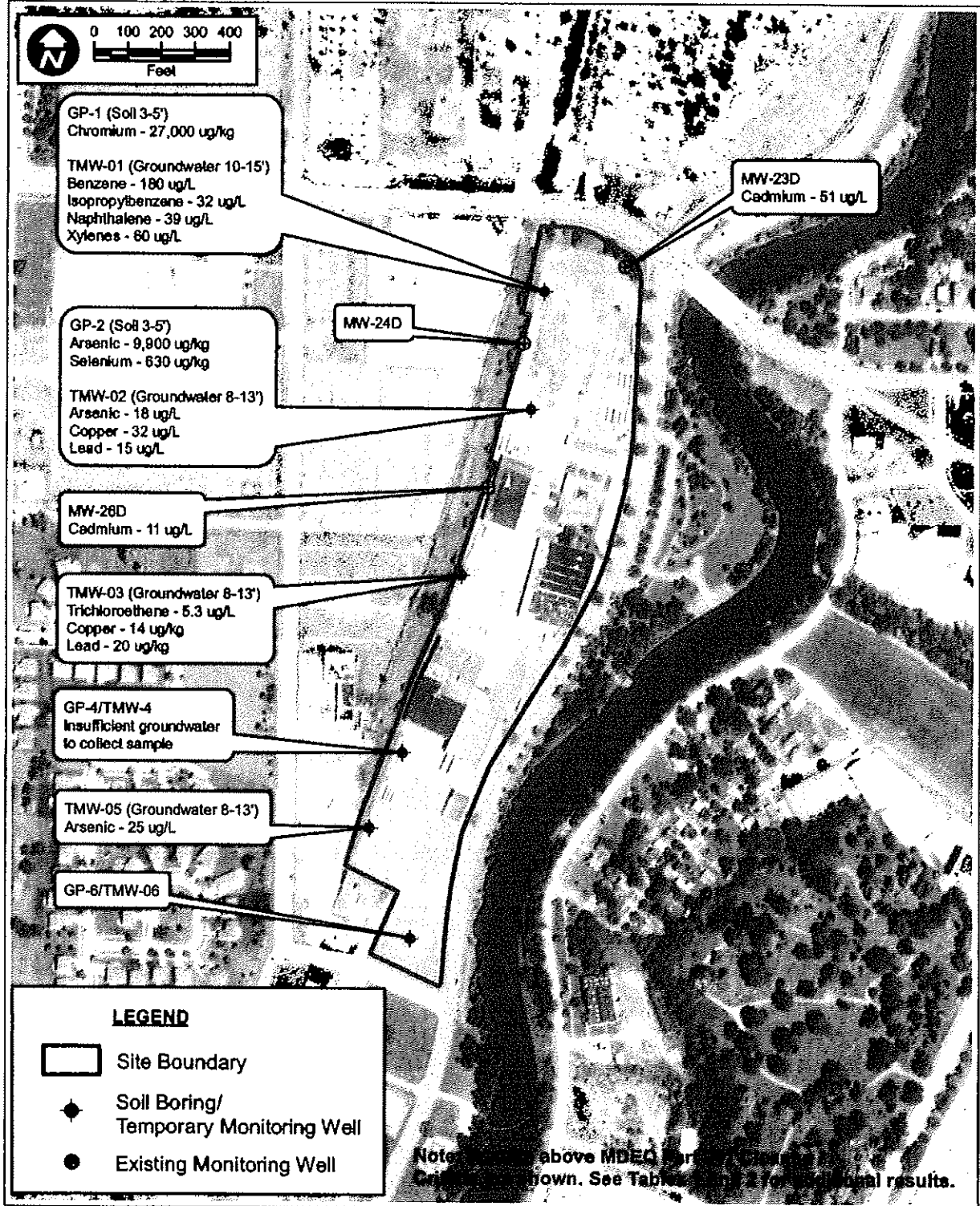

**FIGURE 3.**  
**SAMPLE LOCATION MAP**  
PARCEL IDs: 41-06-452-014 & 41-06-452-015  
FLINT, MI, 48503

Sources: ECT, 2018.

**ECT** Environmental Consulting & Technology, Inc.

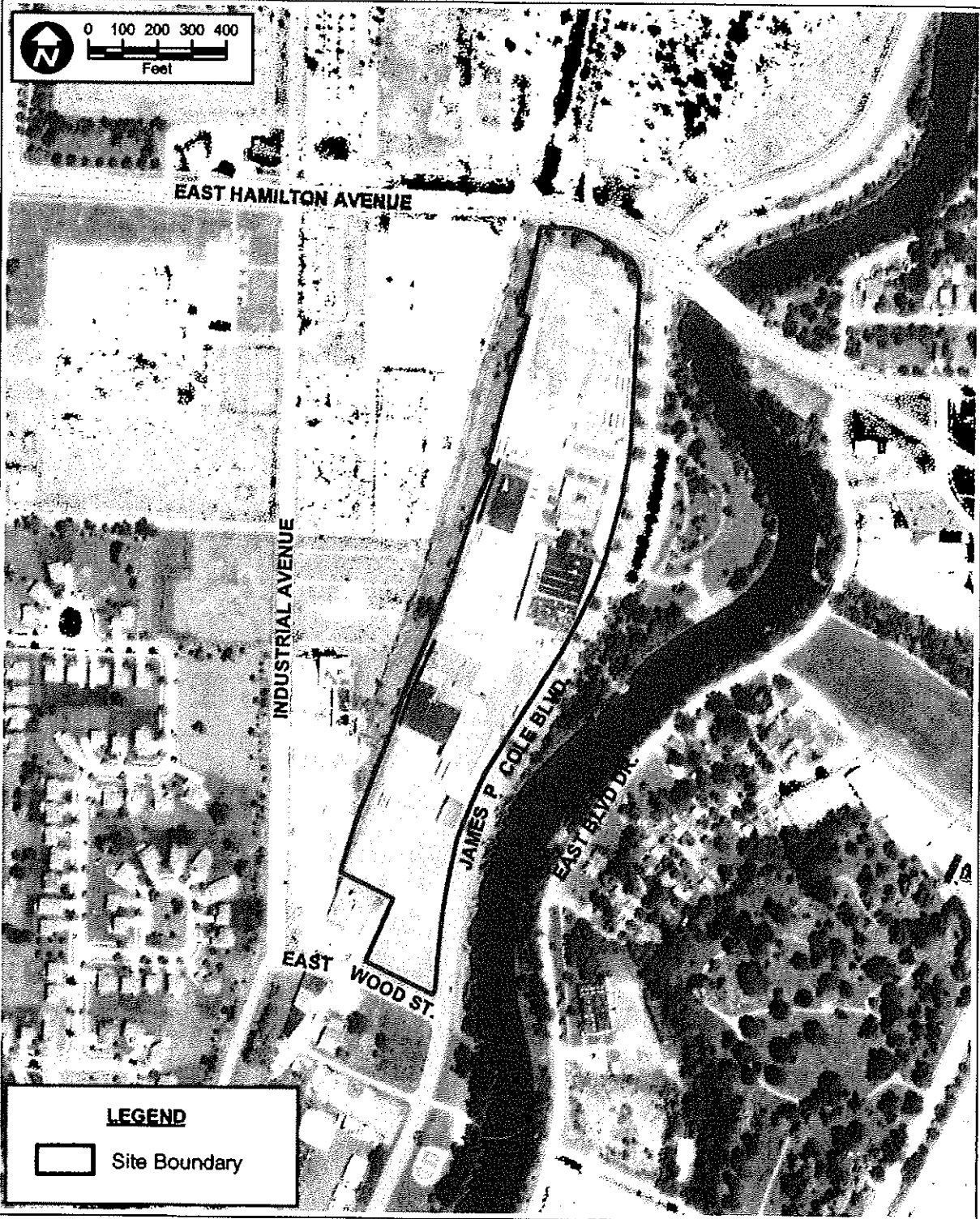

**FIGURE 2.**  
**SITE AND SURROUNDING PROPERTIES MAP**  
PARCEL IDs: 41-06-452-014 & 41-06-452-015  
FLINT, MI. 48503

Source: ECT, 2018.

**ECT** Environmental  
Consulting &  
Technology, Inc.

**Table 1. Soil Analytical Summary**  
Former Dupont Facility

Matrix: Soil  
Cleanup Criteria Residential  
Page 1 of 1

Chemical Abstract Service #	VOCs, ug/kg - Method 8260	Part 201 Cleanup Criteria (December 2013)										Sample Location				
		Residential Criteria					Nonresidential					Sample Location				
		Statewide Default Background	Drinking Water Protection	Groundwater Surface Water Interface	Soil Volatilization to Indoor Air	Infinite Source Volatile Soil Inhalation	Direct Contact	Soil Saturation Concentration Screening Levels	Direct Contact	GP-1 (3-5) 8/20/18	GP-2 (3-5) 8/20/18	GP-5 (6-10) 8/20/18	GP-6 (3-5) 8/20/18			
71432	Benzene	NA	100	240	1,600	13,000	160,000	400,000	400,000	nd	nd	nd	nd	nd	nd	nd
104518	n-Butylbenzene	NA	1,600	ID	ID	ID	2,500,000	10,000,000	8,000,000	nd	nd	nd	nd	nd	nd	nd
135968	sec-Butylbenzene	NA	1,600	ID	ID	ID	2,500,000	10,000,000	8,000,000	nd	nd	nd	nd	nd	nd	nd
107062	1,2-Dichloroethane	NA	100	120	2,100	6,200	91,000	1,200,000	420,000	nd	nd	nd	nd	nd	nd	nd
156552	cis-1,2-Dichloroethene	NA	1,400	12,000	22,000	180,000	640,000	640,000	640,000	nd	nd	nd	nd	nd	nd	nd
156805	trans-1,2-Dichloroethene	NA	2,000	9,400	23,000	280,000	1,400,000	1,400,000	1,400,000	nd	nd	nd	nd	nd	nd	nd
100414	Ethylbenzene	NA	1,500	360	87,000	720,000	140,000	140,000	140,000	nd	nd	nd	nd	nd	nd	nd
127184	Tetrachloroethene	NA	100	220	11,000	170,000	88,000	88,000	88,000	nd	nd	nd	nd	nd	nd	nd
108883	Toluene	NA	16,000	5,400	250,000	2,800,000	250,000	250,000	250,000	nd	nd	nd	nd	nd	nd	nd
71556	1,1,1-Trichloroethane	NA	4,000	1,800	250,000	3,800,000	460,000	460,000	460,000	nd	nd	nd	nd	nd	nd	nd
79016	Trichloroethene	NA	100	580	1,000	11,000	NA	NA	500,000	nd	nd	nd	nd	nd	nd	nd
526738	1,2,3-Trimethylbenzene	NA	NA	NA	NA	NA	NA	NA	NA	nd	nd	nd	nd	nd	nd	nd
95635	1,2,4-Trimethylbenzene	NA	2,100	570	110,000	21,000,000	110,000	110,000	110,000	nd	nd	nd	nd	nd	nd	nd
106678	1,3,5-Trimethylbenzene	NA	1,800	1,100	94,000	16,000,000	94,000	94,000	94,000	nd	nd	nd	nd	nd	nd	nd
75014	Vinyl chloride	NA	40	40	270	4,200	3,800	480,000	34,000	nd	nd	nd	nd	nd	nd	nd
1330207	Xylenes	NA	40	820	150,000	48,000,000	150,000	150,000	150,000	nd	nd	nd	nd	nd	nd	nd
Varies	other VOCs		5,600							nd	nd	nd	nd	nd	nd	nd
83328	Acenaphthene	NA	300,000	8,700	190,000,000	81,000,000	41,000,000	NA	NA	nd	nd	nd	nd	nd	nd	nd
208568	Acenaphthylene	NA	5,900	ID	1,600,000	2,200,000	1,600,000	NA	NA	nd	nd	nd	nd	nd	nd	nd
120127	Anthracene	NA	41,000	ID	1,000,000,000	1,400,000,000	230,000,000	NA	NA	nd	nd	nd	nd	nd	nd	nd
56553	Benzo(a)anthracene	NA	NLL	NLL	NLV	NLV	20,000	NA	80,000	nd	nd	nd	nd	nd	nd	nd
50328	Benzo(b)pyrene	NA	NLL	NLL	NLV	NLV	2,000	NA	8,000	nd	nd	nd	nd	nd	nd	nd
205952	Benzo(f)fluoranthene	NA	NLL	NLL	ID	ID	20,000	NA	80,000	nd	nd	nd	nd	nd	nd	nd
191242	Benzo(g,h)perylene	NA	NLL	NLL	NLV	NLV	2,500,000	NA	7,000,000	nd	nd	nd	nd	nd	nd	nd
207089	Benzo(k)fluoranthene	NA	NLL	NLL	NLV	NLV	200,000	NA	600,000	nd	nd	nd	nd	nd	nd	nd
218019	Chrysene	NA	NLL	NLL	ID	ID	2,000,000	NA	8,000,000	nd	nd	nd	nd	nd	nd	nd
53703	Dibenz(a,h)anthracene	NA	NLL	NLL	NLV	NLV	2,000	NA	8,000	nd	nd	nd	nd	nd	nd	nd
206440	Fluoranthene	NA	730,000	5,500	1,000,000,000	740,000,000	46,000,000	NA	130,000,000	nd	nd	nd	nd	nd	nd	nd
86737	Fluorene	NA	390,000	5,300	580,000,000	130,000,000	27,000,000	NA	87,000,000	nd	nd	nd	nd	nd	nd	nd
193395	Indeno(1,2,3-cd)pyrene	NA	NLL	NLL	NLV	NLV	20,000	NA	80,000	nd	nd	nd	nd	nd	nd	nd
91576	2-Methylnaphthalene	NA	57,000	4,200	2,700,000	1,500,000	810,000	NA	26,000,000	nd	nd	nd	nd	nd	nd	nd
85018	Phenanthrene	NA	56,000	2,100	2,800,000	160,000	1,600,000	NA	5,200,000	nd	nd	nd	nd	nd	nd	nd
129000	Pyrene	NA	480,000	ID	1,000,000,000	650,000,000	29,000,000	NA	84,000,000	nd	nd	nd	nd	nd	nd	nd
7440382	Metals, ug/kg - Method 8020, 7471	5,800	4,600	4,600	NLV	NLV	7,600	NA	37,000	3,200	9,900	1,900	1,400			
7440383	Arsenic	75,000	1,300,000	440,000	NLV	NLV	37,000,000	NA	130,000,000	12,000	64,000	4,100	8,200			
7440439	Cadmium	1,200	6,000	3,000	NLV	NLV	550,000	NA	2,100,000	nd	240	4,000	5,300			
7440508	Chromium (Total)	18,000	30,000	3,300	NLV	NLV	2,500,000	NA	9,200,000	27,000	14,000	4,000	3,100			
7439921	Copper	32,000	5,600,000	75,000	NLV	NLV	20,000,000	NA	73,000,000	4,000	16,000	3,500	2,000			
7439921	Lead	21,000	700,000	2,500,000	NLV	NLV	400,000	NA	900,000	3,400	11,000	2,000	2,000			
7782492	Mercury	130	1,700	50	48,000	52,000	160,000	NA	580,000	nd	82	240	nd			
7440224	Selenium	410	4,000	400	NLV	NLV	2,600,000	NA	9,600,000	nd	630	240	nd			
7440666	Silver	1,000	4,500	100	NLV	NLV	2,500,000	NA	9,000,000	nd	nd	nd	nd			
7440666	Zinc	47,000	2,400,000	170,000	NLV	NLV	170,000,000	NA	630,000,000	16,000	44,000	14,300	19,000			

Note  
ID = insufficient data to develop criterion  
na = not analyzed  
nd = not detected  
NLL = not likely to leach  
NLV = not likely to volatilize

Assumptions  
hardness estimate for receiving waters = 150 mg/L  
protective for surface water that is used as a drinking water source

**Table 2. Groundwater Analytical Summary**

Former Dupont Facility

Matrix: Groundwater

Cleanup Criteria: Residential

Page 1 of 1

Chemical Abstract Service #	Chemical Name	Part 201 Cleanup Criteria (December 2013)						Sample Location									
		Residential Criteria			Groundwater Contact	Sample Location											
		Drinking Water Protection	Domestic Water	Nonresidential Groundwater Surface Water Interface		Indoor Air Inhalation	TMW-1 (10-15) 8/20/18	TMW-2 (9-13) 8/20/18	TMW-3 (9-14) 8/20/18	TMW-5 (9-13) 8/20/18	TMW-6 (4-9) 8/20/18	MW-23D 8/20/18	MW-24D 8/20/18	MW-26D 8/20/18			
VOC, ug/L - Method 8260		730	2,100	1,700	31,000,000	79	nd	nd	nd	nd	nd	nd	nd	nd	nd	nd	nd
Acetone	67641	5.0	5.0	12	11,000	189	nd	nd	nd	nd	nd	nd	nd	nd	nd	nd	nd
Benzene	71432	80	230	ID	5,900	1.8	nd	nd	nd	nd	nd	nd	nd	nd	nd	nd	nd
n-Butylbenzene	104516	80	230	ID	ID	4.8	nd	nd	nd	nd	nd	nd	nd	nd	nd	nd	nd
sec-Butylbenzene	135986	80	230	ID	ID	4.8	nd	nd	nd	nd	nd	nd	nd	nd	nd	nd	nd
1,2-Dichloroethane	107062	5.0	5.0	6.0	9,600	nd	nd	nd	nd	nd	nd	nd	nd	nd	nd	nd	nd
cis-1,2-Dichloroethane	156552	70	620	620	200,000	nd	nd	nd	nd	nd	nd	nd	nd	nd	nd	nd	nd
trans-1,2-Dichloroethane	156550	100	100	470	85,000	nd	nd	nd	nd	nd	nd	nd	nd	nd	nd	nd	nd
Ethylbenzene	100414	74	74	74	110,000	5.6	nd	nd	nd	nd	nd	nd	nd	nd	nd	nd	nd
Isopropylbenzene	98828	800	2,300	28	56,000	32	nd	nd	nd	nd	nd	nd	nd	nd	nd	nd	nd
n-Propylbenzene	103851	520	1,500	11	31,000	39	nd	nd	nd	nd	nd	nd	nd	nd	nd	nd	nd
Naphthalene	107184	80	230	ID	ID	26	nd	nd	nd	nd	nd	nd	nd	nd	nd	nd	nd
Tetrachloroethene	108883	790	790	11	25,000	25	nd	nd	nd	nd	nd	nd	nd	nd	nd	nd	nd
Toluene	71556	200	200	88	530,000	nd	nd	nd	nd	nd	nd	nd	nd	nd	nd	nd	nd
1,1,1-Trichloroethane	79016	5.0	5.0	29	660,000	nd	nd	nd	nd	nd	nd	nd	nd	nd	nd	nd	nd
Trichloroethene	75684	2,600	7,300	NA	1,100,000	5.3	nd	nd	nd	nd	nd	nd	nd	nd	nd	nd	nd
Trichlorobromomethane	626738	NA	NA	NA	NA	5.6	nd	nd	nd	nd	nd	nd	nd	nd	nd	nd	nd
1,2,4-Trimethylbenzene	95636	63	63	17	56,000	9.1	nd	nd	nd	nd	nd	nd	nd	nd	nd	nd	nd
1,3,5-Trimethylbenzene	108678	72	72	45	61,000	3.0	nd	nd	nd	nd	nd	nd	nd	nd	nd	nd	nd
Vinyl chloride	75014	2.0	2.0	1.0	1,100	60	nd	nd	nd	nd	nd	nd	nd	nd	nd	nd	nd
Xylenes	1330207	280	280	44	180,000	nd	nd	nd	nd	nd	nd	nd	nd	nd	nd	nd	nd
Other VOCs	Values					nd	nd	nd	nd	nd	nd	nd	nd	nd	nd	nd	nd
PNA, ug/L - Method 8276		1,300	3,800	38	4,200	nd	nd	nd	nd	nd	nd	nd	nd	nd	nd	nd	nd
Acetanaphthene	81329	52	150	ID	3,900	nd	nd	nd	nd	nd	nd	nd	nd	nd	nd	nd	nd
Acenaphthylene	208958	45	45	ID	43	nd	nd	nd	nd	nd	nd	nd	nd	nd	nd	nd	nd
Anthracene	120127	2.1	6.5	ID	NLV	nd	nd	nd	nd	nd	nd	nd	nd	nd	nd	nd	nd
Benzo[a]anthracene	56553	5.0	5.0	ID	NLV	nd	nd	nd	nd	nd	nd	nd	nd	nd	nd	nd	nd
Benzo[b]fluoranthene	208982	1.5	1.5	ID	ID	nd	nd	nd	nd	nd	nd	nd	nd	nd	nd	nd	nd
Benzo[k]fluoranthene	197242	1.0	1.0	ID	NLV	nd	nd	nd	nd	nd	nd	nd	nd	nd	nd	nd	nd
Benzo[a]fluoranthene	207069	1.0	1.0	NA	NLV	nd	nd	nd	nd	nd	nd	nd	nd	nd	nd	nd	nd
Chrysene	218019	1.6	1.6	ID	ID	nd	nd	nd	nd	nd	nd	nd	nd	nd	nd	nd	nd
Dibenz[a,h]anthracene	53703	2.0	2.0	ID	NLV	nd	nd	nd	nd	nd	nd	nd	nd	nd	nd	nd	nd
Fluoranthene	206440	210	210	1.6	210	nd	nd	nd	nd	nd	nd	nd	nd	nd	nd	nd	nd
Fluorene	96737	980	2,000	12	2,000	nd	nd	nd	nd	nd	nd	nd	nd	nd	nd	nd	nd
Indeno(1,2,3-cd)pyrene	193395	2.0	750	19	NLV	nd	nd	nd	nd	nd	nd	nd	nd	nd	nd	nd	nd
2-Methylnaphthalene	91576	260	1,500	11	31,000	39	nd	nd	nd	nd	nd	nd	nd	nd	nd	nd	nd
Naphthalene	91203	520	1,500	11	31,000	nd	nd	nd	nd	nd	nd	nd	nd	nd	nd	nd	nd
Phenanthrene	85018	52	150	2.0	1,000	nd	nd	nd	nd	nd	nd	nd	nd	nd	nd	nd	nd
Pyrene	129500	140	140	ID	140	nd	nd	nd	nd	nd	nd	nd	nd	nd	nd	nd	nd
Metals, ug/L - Method 6020, 7470		10	10	10	NLV	nd	nd	nd	nd	nd	nd	nd	nd	nd	nd	nd	nd
Arsenic	7440382	2,000	2,000.0	670	14,000,000	nd	nd	nd	nd	nd	nd	nd	nd	nd	nd	nd	nd
Barium	7440393	5.0	5.0	2.5	190,000	nd	nd	nd	nd	nd	nd	nd	nd	nd	nd	nd	nd
Cadmium	7440439	100	100	13	460,000	nd	nd	nd	nd	nd	nd	nd	nd	nd	nd	nd	nd
Chromium (Total)	18540299	1,000	1,000.0	13	7,400,000	nd	nd	nd	nd	nd	nd	nd	nd	nd	nd	nd	nd
Copper	7440508	4.0	4.0	14	ID	nd	nd	nd	nd	nd	nd	nd	nd	nd	nd	nd	nd
Lead	7439921	2.0	2.0	0.0013	56	nd	nd	nd	nd	nd	nd	nd	nd	nd	nd	nd	nd
Mercury	Values	50	50	5.0	NLV	nd	nd	nd	nd	nd	nd	nd	nd	nd	nd	nd	nd
Selenium	7782492	34	98	0.20	NLV	nd	nd	nd	nd	nd	nd	nd	nd	nd	nd	nd	nd
Silver	7440224	2,400	5,000	170	110,000,000	nd	nd	nd	nd	nd	nd	nd	nd	nd	nd	nd	nd
Zinc	7440666	0.50	0.50	0.20	45	nd	nd	nd	nd	nd	nd	nd	nd	nd	nd	nd	nd
PCBs, ug/L - Method 6020, 7471		0.50	0.50	0.20	45	nd	nd	nd	nd	nd	nd	nd	nd	nd	nd	nd	nd
polychlorinated biphenyls (PCBs)	1336363					nd	nd	nd	nd	nd	nd	nd	nd	nd	nd	nd	nd

Notes:  
 ID = insufficient data to develop criterion  
 NA = not available  
 nd = not detected  
 NLV = not likely to volatilize

Assumptions:  
 hardness estimate for receiving waters = 150 mg/L  
 protective for surface water that is used as a drinking water source

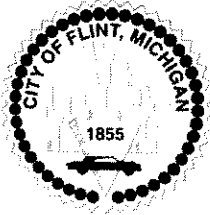

RESOLUTION NO.: 210252

PRESENTED: JUN - 6 2021

ADOPTED: \_\_\_\_\_

PROPOSAL# 18-007

BY THE CITY ADMINISTRATOR:

**RESOLUTION TO BOYD’S LAWN AND LANDSCAPING FOR  
MOWING OF PARKS, TRAILS, CEMETERIES, CENTERS, AND TRIANGLES**

WHEREAS, the Department of Planning and Development (Planning) is requires mowing services for parks, trails, cemeteries, centers, and triangles. Planning recommended the purchase of mowing services for 2018-2022 to Boyd’s Lawn and Landscaping, and is requesting the fourth year (change order #3) of mowing through June 30, 2022 in the amount of \$154,500.

Account Number	Account Name	Amount
208-752.102-801.000	Professional Services	\$154,500.00
	<b>FY2022 GRAND TOTAL</b>	<b>\$154,500.00</b>

IT IS RESOLVED, that the appropriate City Officials are authorized to do all things necessary to enter into the fourth year of the contract with Boyd’s Lawn and Landscaping to provide mowing services for parks, trails, cemeteries, centers, and triangles for FY2022, pending the adoption of the budget, for the amount of \$154,500.

APPROVED AS TO FORM:

Angela Wheeler  
Angela Wheeler (May 25, 2021 13:12 EDT)

Angela Wheeler, Chief Legal Officer

APPROVED AS TO FINANCE:

Shelbi Frayer  
shelbi frayer (May 26, 2021 09:07 EDT)

Shelbi Frayer, Chief Financial Officer

FOR THE CITY OF FLINT:

Clyde D Edwards  
CLYDE D EDWARDS (May 27, 2021 13:16 EDT)

Clyde Edwards, City Administrator

APPROVED BY CITY COUNCIL:

\_\_\_\_\_  
Kate Fields, City Council President

APPROVED AS TO PURCHASING:

Jennifer Ryan  
Jennifer Ryan (May 25, 2021 12:15 EDT)

Jenn Ryan, Deputy Finance Director



# CITY OF FLINT

## RESOLUTION STAFF REVIEW FORM

TODAY'S DATE: 03/29/2021

BID/PROPOSAL#

AGENDA ITEM TITLE: Change Order #3 for extension of the contract with Boyd's Lawn &

Landscaping for mowing of park property from July 1 2021 to June 30, 2022.

**PREPARED BY**

Mary Jarvis, Planning and Development

VENDOR NAME: Boyd's Lawn & Landscaping

**BACKGROUND/SUMMARY OF PROPOSED ACTION:**

The Department of Planning & Development is requesting to enter the forth phase of mowing parkland from July 1 2021 to June 30, 2022 in the amount of \$154,500.00.

FINANCIAL IMPLICATIONS: \$154,500 from the Parks and Recreation Fund Professional Service account.

BUDGETED EXPENDITURE? YES  NO  IF NO, PLEASE EXPLAIN:

Dept.	Name of Account	Account Number	Grant Code	Amount
Parks	Parks and Recreation Fund Professional Service account	208-752.102-801.000	N/A	\$154,500.00
		<b>FY21/22 GRAND TOTAL</b>		<b>\$154,500.00</b>

PRE-ENCUMBERED? YES  NO  REQUISITION NO: 210004281

ACCOUNTING APPROVAL: Mary Jarvis Date: 03/29/2020

FINANCE APPROVAL: \_\_\_\_\_ Date: \_\_\_\_\_





## CITY OF FLINT

---

**WILL YOUR DEPARTMENT NEED A CONTRACT?** YES  NO

*(If yes, please indicate how many years for the contract)* YEARS

**WHEN APPLICABLE, IF MORE THAN ONE (1) YEAR, PLEASE ESTIMATE TOTAL AMOUNT FOR EACH BUDGET YEAR: (This will depend on the term of the bid proposal)**

**BUDGET YEAR 1**

**BUDGET YEAR 2**

**BUDGET YEAR 3**

**OTHER IMPLICATIONS (i.e., collective bargaining):** None

**STAFF RECOMMENDATION: (PLEASE SELECT):**  **APPROVED**  **NOT APPROVED**

**DEPARTMENT HEAD SIGNATURE:**

---

*Suzanne Wilcox, Planning & Development Director*



RESOLUTION NO.: 200255

PRESENTED: JUN 22 2020

ADOPTED: 6-24-2020

**CHANGE ORDER #2: RESOLUTION APPROVING EXTENSION OF CONTRACT WITH BOYD'S LAWN AND LANDSCAPING FOR MOWING OF PARKS, TRAILS, CEMETERIES, CENTERS AND TRIANGLES**

**BY THE MAYOR:**

WHEREAS, On February 14, 2018, the City of Flint entered into a contract with Boyd's Lawn and Landscaping, 5103 W. Coldwater Rd., Flint, Michigan (resolution #180054) for the mowing of parks, trails, cemeteries, centers, and triangles for the first phase of a five year period (2018-2022) in the amount of \$120,600.00 as requested by Planning & Development; and

WHEREAS, The Department of Planning & Development is requesting the third year of mowing through June 30, 2021 in the amount of \$154,500.00. Funding for said services will come from the following account: 208-752.102-801.000 (Park/Recreation Fund); and

IT IS RESOLVED that appropriate City Officials are authorized to do all things necessary to enter into change order #2 to the contract with Boyd's Lawn & Landscaping for the third year of mowing parks, trails, cemeteries, centers, and triangles through June 30, 2021 in the amount not to exceed \$154,500.00 and an aggregate amount of \$534,852.00.

**APPROVED AS TO FINANCE:**

Amanda Trujillo  
Amanda Trujillo  
Deputy Finance Director

**APPROVED AS TO FORM:**

Angela Wheeler  
Angela Wheeler  
Chief Legal Officer

**ADMINISTRATION:**

Sheldon Neeley  
Sheldon Neeley  
Mayor

**CITY COUNCIL:**

Monica Galloway  
Monica Galloway  
City Council President

*[Handwritten signature]*



CITY OF FLINT

RESOLUTION STAFF REVIEW FORM

TODAY'S DATE: 06/11/2020

BID/PROPOSAL#: N/A

AGENDA ITEM TITLE: CHANGE ORDER #2: RESOLUTION APPROVING EXTENSION OF CONTRACT WITH BOYD'S LAWN AND LANDSCAPING FOR MOWING OF PARKS, TRAILS, CEMETERIES, CENTERS AND TRIANGLES

PREPARED BY: Alissa Paquette, Planning

VENDOR NAME: Boyd's Lawn and Landscaping

BACKGROUND/SUMMARY OF PROPOSED ACTION:

On February 14, 2018, the Proper City Officials were authorized to enter into a contract with Boyd's Lawn and Landscaping, 5103 W. Coldwater Rd., Flint, Michigan (resolution #180054) for the mowing of parks, trails, cemeteries, centers, and triangles for the first phase of a five-year period (2018-2022) in the amount of \$120,600.00 as requested by Planning & Development. This contract period was April 2018 to November 2018.

On March 25, 2019, the Department of Planning & Development was authorized to enter into the second year of mowing through June 30, 2020 in the amount of \$259,752.00. The proper City Officials, upon City Council's approval, were authorized to enter into change order #1 of the contract with Boyd's Lawn & Landscaping for the second year of services from April 2019 through June 30, 2020 for an aggregate amount of \$380,352.00.

The Department of Planning & Development is requesting to enter the third phase of mowing for July 1, 2020 through June 30, 2021 in the amount of \$154,500.00.

FINANCIAL IMPLICATIONS: This delivers no impact to the City's General Fund accounts.

BUDGETED EXPENDITURE? YES [X] NO [ ] IF NO, PLEASE EXPLAIN:

Table with 5 columns: Dept., Name of Account, Account Number, Grant Code, Amount. Row 1: DPD, Park/Recreation Fund, 208-752.102-801.000, N/A, \$154,500.00. Row 2: FY19/20 GRAND TOTAL, \$154,500.00

PRE-ENCUMBERED? YES [ ] NO [X] REQUISITION NO: 200003363 Funds cannot be encumbered until the FY2021 budget is uploaded.

ACCOUNTING APPROVAL: Mary Jarvis Date: 06/12/2020



# CITY OF FLINT

---

**WILL YOUR DEPARTMENT NEED A CONTRACT?** YES  NO   
(If yes, please indicate how many years for the contract) \_\_\_\_\_ YEARS

**WHEN APPLICABLE, IF MORE THAN ONE (1) YEAR, PLEASE ESTIMATE TOTAL AMOUNT FOR EACH BUDGET YEAR:** (This will depend on the term of the bid proposal)

BUDGET YEAR 1

BUDGET YEAR 2

BUDGET YEAR 3

**OTHER IMPLICATIONS (i.e., collective bargaining):**

**STAFF RECOMMENDATION:** (PLEASE SELECT):  **APPROVED**  **NOT APPROVED**

**DEPARTMENT HEAD SIGNATURE:** *Stephanie Williams* Director, Department of Planning and Dev.  
(PLEASE TYPE NAME, TITLE)

**DPD**

**18-007**

# **CITY OF FLINT MICHIGAN**



**Boyd's Lawn & Landscaping  
FY 2017-18  
Parks Mowing & Trimming Services  
\$120,600.00**

# **CONTRACTS**

190103

(Purchasing #18000027)

SUBMISSION NO.:

PRESENTED: 3-21-19

ADOPTED: 3-25-2019

BY THE CITY ADMINISTRATOR:

**RESOLUTION TO BOYD'S LAWN & LANDSCAPING FOR MOWING OF PARKS, TRAILS, CEMETERIES, CENTERS AND TRIANGLES**

**RESOLUTION**

On February 14, 2018, the Proper City Officials were authorized to enter into a contract with Boyd's Lawn & Landscaping, 5103 W. Coldwater Rd., Flint, Michigan (resolution #180054) for the mowing of parks, trails, cemeteries, centers and triangles for the first year of a five year period in the amount of \$120,600.00 as requested by Planning & Development; and

The Department of Planning & Development has requested the second year of mowing through June 30, 2020 in the amount of \$259,732.00. Funding for said services will come from the following account: 208-752.102-801.000; and

IT IS RESOLVED, that the Proper City Officials, upon City Council's approval, are hereby authorized to enter into change order #1 to the contract with Boyd's Lawn & Landscaping for the second year of mowing parks, trails, cemeteries, centers and triangles through June 30, 2020 in the amount not to exceed \$259,732.00 and an aggregate amount of \$380,352.00. (Park/Recreation Fund) \$86,574.00 FY19, \$173,148.00 pending adoption of the FY20 budget

APPROVED PURCHASING DEPT

  
Bryan B. Bond  
Interim Purchasing Manager

APPROVED AS TO FINANCE:

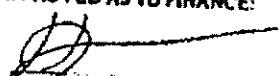
  
Hughey Newsome  
Chief Financial Officer

APPROVED AS TO FORM

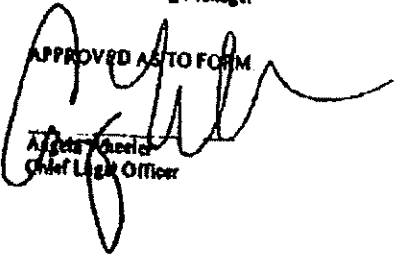
  
A. J. Gabel  
Chief Legal Officer

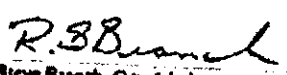
  
Steve Branch, City Administrator

  
Herbert J. Winfrey, President  
City Council

**CHANGE ORDER**

SUBMISSION NO.: 190103

ADOPTED DATE: 3-25-2019

NAME OF PROJECT: Park Mowing and Trimming Services 19-6083

CONTRACTOR: Boyd's Lawn and Landscaping

The following changes are hereby made to the contract document:

The Department of Planning & Development was authorized by the Flint City Council on March 25<sup>th</sup> to enter into the second year of a five year contract with Boyd's Lawn and Landscaping for mowing of parks, trails, cemeteries, centers, and triangles in the amount not to exceed \$259,752.00 with a revised aggregate amount of \$380,352.00. This contract will cover mowing and trimming services until June 30<sup>th</sup>, 2020 and includes additional properties. Resolution #190103 is attached as is a Notice to Enter into Contract from the City's Purchasing Manager.

**CHANGE TO CONTRACT PRICE**

ORIGINAL CONTRACT AMOUNT: \$ \$120,600.00

CURRENT CONTRACT AMOUNT ADJUSTED BY PREVIOUS CHANGE ORDERS: \$ 0.00

THE CONTRACT AMOUNT DUE TO THIS CHANGE ORDER WILL BE INCREASED BY: \$ 259,752.00

THE NEW CONTRACT AMOUNT DUE TO THIS CHANGE ORDER WILL BE: \$ 380,352.00

CONTRACT TIME CHANGE -

ACCEPTED: CONTRACTOR

FIRM: Boyd's Lawn and Landscaping

BY: Jan Boyd

TITLE: Owner

ADDRESS: 5103 W Caldwell Rd Flint MI

APPROVED AS TO FORM:

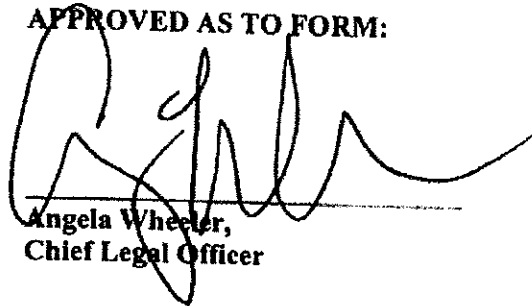
  
Angela Wheeler,  
Chief Legal Officer

BY:

THE CITY OF FLINT  
A MUNICIPAL CORPORATION

  
Dr/ Karen W. Weaver,  
Mayor



# CITY OF FLINT

## Department of Purchases & Supplies

Dr. Karen Weaver  
Mayor

Joyce A. McClane  
Purchasing Manager

April 11, 2019

**TO:** Suzanne Wilcox, Director  
Planning & Development

**FROM:** Joyce A. McClane *JAM*  
Purchasing Manager

**SUBJECT:** NOTICE TO ENTER INTO A CONTRACT – BOYD'S LAWN & LANDSCAPING

Please be advised that the abovementioned vendor has been approved by City Council on March 25, 2019 for change order #1 to the contract for the second year of a three year mowing of parks, trails, cemeteries, centers and triangles in an amount not to exceed \$259,752.00 and a revised aggregate amount of \$380,352.00. You are now authorized to enter into a contract with Boyd's Lawn & Landscaping.

If you have any questions, please feel free to give me a call.

Attachment



**CITY OF FLINT CONTRACT WITH  
Boyd's Lawn and Landscaping**

The purpose of this agreement is to enter into a contract to provide equipment and mowing & trimming services for parks, traffic triangles, and traffic medians (hereinafter "Services") for the City of Flint (hereinafter "City") and Boyd's Lawn and Landscaping. (hereinafter "Contractor").

**Applicable Law:** This contract shall be governed by and interpreted according to the laws of the State of Michigan pertaining to contracts made and to be performed in this state.

**Arbitration:** Contractor agrees that for all claims, disputes, and other matters arising out of or relating to this agreement, Contractor must request the City's consent to arbitrate within 30 days from the date the Contractor knows or should have known the facts giving rise to the claim, dispute or question.

(a) Notice of a request for arbitration must be submitted in writing by certified mail or personal service upon the City Attorney.

(b) Within 60 days from the date a request for arbitration is received by the City, the City shall inform Contractor whether it agrees to arbitrate. If the City does not consent, Contractor may proceed with an action in a court of competent jurisdiction within the State of Michigan. If the City does consent, then within 30 days of the consent each party shall submit to the other the name of one person to serve as an arbitrator. The two arbitrators together shall then select a third person, the three together shall then serve as a panel in all proceedings. Any unanimous decision of the three arbitrators shall be a final binding decision. The City's failure to respond to a timely, conforming request for arbitration is deemed consent to arbitration.

(c) The costs of the arbitration shall be split and borne equally between the parties and such costs are not subject to shifting by the arbitrator.

(d) Contractor's failure to comply with any portion (including timeliness) of this provision shall be deemed a permanent waiver and forfeiture of the claim, dispute, or question.

(e) These provisions shall survive the termination or expiration of this agreement.

**City Income Tax Withholding:** Contractor and any subcontractor engaged in this contract shall withhold from each payment to his employees the City income tax on all of their compensation subject to tax, after giving effect to exemptions, as follows:

(a) Residents of the City:

At a rate equal to 1% of all compensation paid to the employee who is a resident of the City of Flint.

(b) Non-residents:

At a rate equal to ½ % of the compensation paid to the employee for work done or services performed in the City of Flint.

These taxes shall be held in trust and paid over to the City of Flint in accordance with City ordinances and State law. Any failure to do so shall constitute a substantial and material breach of this contract.

**Compensation:** The City shall pay for requested services as have been set forth herein, a total contract price not to exceed \$120,600.00 upon submission of proper invoices, releases, affidavits, and the like. Contractor recognizes that the City does not guarantee it will require any set amount of services. Contractor's services will be utilized as needed and as determined solely by the City of Flint. Contractor expressly recognizes that it has no right to payment of any amount exceeding \$120,600.00. Contractor agrees that oral agreements by City officials to pay a greater amount are not binding.

1. Contractor shall submit itemized invoices on a monthly basis for all services provided under this Agreement identifying:

(a) The date of service

(b) The name of person providing the service and a general description of the service provided

(c) The unit rate and the total amount due. Invoices shall be submitted to by e-mail to: accountspayable@cityofflint.com and Amoore@cityofflint.com (City of Flint, Planner II)

It is solely within the discretion of the City as to whether Contractor has provided a proper invoice. The City may require additional information or waive requirements as it sees fit. The City will notify the Contractor of any errors or lack of sufficient documentation within 14 days of receipt of the invoice.

**Contract Documents:** The invitation for bids, instructions to bidders, proposal, affidavit, addenda (if any), statement of bidder's qualifications (when required), general conditions, special conditions, performance bond, labor and material payment bond, insurance certificates, technical specifications, and drawings, together with this agreement, form the contract, and they are as fully a part of the contract as if attached hereto or repeated herein.

**Disclaimer of Contractual Relationship With Subcontractors:** Nothing contained in the Contract Documents shall create any contractual relationship between the City and any Subcontractor or Sub-subcontractor.

**Effective Date:** This contract shall be effective upon the date that it is executed by all parties and presented to the City of Flint Clerk.

**Certification, Licensing, Debarment, Suspension and Other Responsibilities:** Contractor warrants and certifies that Contractor and/or any of its principals are properly certified and licensed to perform the duties required by this contract in accord with laws, rules,

and regulations, and is not presently debarred, suspended, proposed for debarment or declared ineligible for the award of any Federal contracts by any Federal agency. Contractor may not continue to or be compensated for any work performed during any time period where the debarment, suspension or ineligibility described above exists or may arise in the course of Contractor contractual relationship with the City. Failure to comply with this section constitutes a material breach of this Contract. Should it be determined that contractor performed work under this contract while in non-compliance with this provision, Contractor agrees to reimburse the City for any costs that the City must repay to any and all entities.

**Force Majeure:** Neither party shall be responsible for damages or delays caused by Force Majeure or other events beyond the control of the other party and which could not reasonably have been anticipated or prevented. For purposes of this Agreement, Force Majeure includes, but is not limited to, adverse weather conditions, floods, epidemics, war, riot, strikes, lockouts, and other industrial disturbances; unknown site conditions, accidents, sabotage, fire, and acts of God. Should Force Majeure occur, the parties shall mutually agree on the terms and conditions upon which the services may continue.

**Good Standing:** Contractor must remain current and not be in default of any obligations due the City of Flint, including the payment of taxes, fines, penalties, licenses, or other monies due the City of Flint. Violations of this clause shall constitute a substantial and material breach of this contract. Such breach shall constitute good cause for the termination of this contract should the City of Flint decide to terminate on such basis.

**Hold Harmless and Indemnification:** To the fullest extent permitted by law, Contractor agrees to defend, pay on behalf of, indemnify, and hold harmless the City, its elected and appointed officials, employees, volunteers and others working on behalf of the City, against any and all claims, demands, suits, or losses, including all costs connected therewith, and for any and all damages which may be asserted, claimed, or recovered against or from the City, its elected and appointed officials, employees, volunteers or others working on behalf of the City, arising out of this Agreement, including but not limited to those by reason of personal injury, including bodily injury or death and/or property damage, including loss of use thereof, including those which may arise as a result of Contractor's acts, omissions, faults, and negligence or that of any of his employees, agents, and representatives. Should the Contractor fail to indemnify the City in the above-mentioned circumstances, the City may deduct the cost that it incurs from amounts owing under the Agreement without prior notice. These provisions shall survive the termination on expiration of this agreement.

**Independent Contractor:** No provision of this contract shall be construed as creating an employer-employee relationship. It is hereby expressly understood and agreed that Contractor is an "independent contractor" as that phrase has been defined and interpreted by the courts of the State of Michigan and, as such, Contractor is not entitled to any benefits not otherwise specified herein.

**Insurance/Worker's Compensation:** Contractor shall not commence work under this contract until he has procured and provided evidence of the insurance required under this

section. All coverage shall be obtained from insurance companies licensed and authorized to do business in the State of Michigan unless otherwise approved by the City's Risk Manager. Policies shall be reviewed by the City's Risk Manager for completeness and limits of coverage. All coverage shall be with insurance carriers acceptable to the City of Flint. Contractor shall maintain the following insurance coverage for the duration of the contract.

(a) Commercial General Liability coverage of not less than one million dollars (\$1,000,000) combined single limit with the City of Flint, and including all elected and appointed officials, all employees and volunteers, all boards, commissions and/or authorities and their board members, employees and volunteers, named as "Additional Insureds." This coverage shall be written on an ISO occurrence basis form and shall include: Bodily Injury, Personal Injury, Property Damage, Contractual Liability, Products and Completed Operations, Independent Contractors; Broad Form Commercial General Liability Endorsement, (XCU) Exclusions deleted and a per contract aggregate coverage. This coverage shall be primary to the Additional Insureds, and not contributing with any other insurance or similar protection available to the Additional Insureds, whether said other available coverage be primary, contributing, or excess.

(b) Workers Compensation Insurance in accordance with Michigan statutory requirements, including Employers Liability coverage.

(c) Commercial Automobile Insurance in the amount of not less than \$1,000,000 combined single limit per accident with the City of Flint, and including all elected and appointed officials, all employees and volunteers, all boards, commissions and/or authorities and their board members, employees and volunteers, named as "Additional Insureds." This coverage shall be written on ISO business auto forms covering Automobile Liability, code "any auto."

(d) Professional Liability - Errors and Omissions. All projects involving the use of Architects, civil engineers, landscape design specialists, and other professional services must provide the City of Flint with evidence of Professional Liability coverage in an amount not less than one million dollars (\$1,000,000). Evidence of this coverage must be provided for a minimum of three years after project completion. Any deductibles or self-insured retention must be declared to and approved by the City. In addition, the total dollar value of all claims paid out on the policy shall be declared. At the option of the City, either the insurer shall reduce or eliminate such deductibles or self-insured retention with respect to the City, its officials, employees, agents and volunteers; or Contractor shall procure a bond guaranteeing payment of losses and related investigation, claim, administration, and defense expenses.

Contractor shall furnish the City with two certificates of insurance for all coverage requested with original endorsements for those policies requiring the Additional Insureds. All certificates of insurance must provide the City of Flint with not less than 30 days advance written notice in the event of cancellation, non-payment of premium, non-renewal, or any material change in policy coverage. In addition, the wording "Endeavor to" and "but failure to mail such notice shall impose no obligation or liability of any kind

upon the company, its agents or representatives" must be removed from the standard ACORD cancellation statement. These certificates must identify the City of Flint, Risk Management Division, as the "Certificate Holder." Contractor must provide, upon request, certified copies of all insurance policies. If any of the above policies are due to expire during the term of this contract, Contractor shall deliver renewal certificates and copies of the new policies to the City of Flint at least ten days prior to the expiration date. Contractor shall ensure that all subcontractors utilized obtain and maintain all insurance coverage required by this provision.

**Laws and Ordinances:** Contractor shall obey and abide by all of the laws, rules and regulations of the Federal Government, State of Michigan, Genesee County and the City of Flint, applicable to the performance of this agreement, including, but not limited to, labor laws, and laws regulating or applying to public improvements.

**Modifications:** Any modifications to this contract must be in writing and signed by the parties or the authorized employee, officer, board or council representative of the parties authorized to make such contractual modifications under State law and local ordinances.

**No Third-Party Beneficiary:** No contractor, subcontractor, mechanic, materialman, laborer, vendor, or other person dealing with the principal Contractor shall be, nor shall any of them be deemed to be, third-party beneficiaries of this contract, but each such person shall be deemed to have agreed (a) that they shall look to the principal Contractor as their sole source of recovery if not paid, and (b) except as otherwise agreed to by the principal Contractor and any such person in writing, they may not enter any claim or bring any such action against the City under any circumstances. Except as provided by law, or as otherwise agreed to in writing between the City and such person, each such person shall be deemed to have waived in writing all rights to seek redress from the City under any circumstances whatsoever.

**Non-Assignability:** Contractor shall not assign or transfer any interest in this contract without the prior written consent of the City provided, however, that claims for money due or to become due to Contractor from the City under this contract may be assigned to a bank, trust company, or other financial institution without such approval. Notice of any such assignment or transfer shall be furnished promptly to the City.

**Non-Disclosure/Confidentiality:** Contractor agrees that the documents identified herein as the contract documents are confidential information intended for the sole use of the City and that Contractor will not disclose any such information, or in any other way make such documents public, without the express written approval of the City or the order of the court of appropriate jurisdiction or as required by the laws of the State of Michigan.

**Non-Discrimination:** Contractor shall not discriminate against any employee or applicant for employment with respect to hiring or tenure; terms, conditions, or privileges of employment; or any matter directly or indirectly related to employment, because of race, color, creed, religion, ancestry, national origin, age, sex, height, weight, disability or other physical impairment, marital status, or status with respect to public assistance.

**Notices:** Notices to the City of Flint shall be deemed sufficient if in writing and mailed,

postage prepaid, addressed to Adam Moore, Planner II, City of Flint, 1101 S. Saginaw Street, Room B17, Flint, Michigan 48502 and Inez Brown, City Clerk, City of Flint, 1101 S. Saginaw Street, Flint, Michigan 48502, or to such other address as may be designated in writing by the City from time to time. Notices to Contractor shall be deemed sufficient if in writing and mailed, postage prepaid, addressed to 5103 W. Coldwater Rd. Flint, MI 48504, or to such other address as may be designated in writing by Contractor from time to time.

**R-12 Prevailing Wages:** Contractor is aware of City of Flint Resolution #R-12 dated April 8, 1991, which is hereby incorporated by reference, and agrees to abide by all of the applicable covenants and requirements set forth in said resolution.

**Records Property of City:** All documents, information, reports and the like prepared or generated by Contractor as a result of this contract shall become the sole property of the City of Flint.

**Scope of Services:** Contractor shall provide all of the materials, equipment, supplies, tools, superintendence and other accessories and services necessary to complete the project in accordance with the proposals submitted opened on February 2, 2018.

Work will be conducted between the spring and fall of 2018 and may be subject for individual annual renewal in 2019, 2020, 2021, and 2022. It is the City's intention that parks, cemeteries, trails, medians, and traffic triangles will be mowed bi-weekly at least 14 times a year with 6 optional mows used at the City's discretion, however, no minimum amount of work is guaranteed. City Hall and fire stations will be mowed weekly, or at the City's discretion. Work done around fire stations and City Hall will be managed by the Department of Public Works

**Location of Services: Parks**

<b>ZONE 1 (Northwest)</b>		<b>Single Cut</b>		<b>Double Cut</b>
Bassett Park	\$	450.00	\$	900.00
McClellan Park	\$	20.00	\$	40.00
Clara Hilborn Park	\$	140.00	\$	280.00
Fleming Park	\$	40.00	\$	80.00
Hasselbring Park	\$	450.00	\$	900.00
Iroquois Park	\$	120.00	\$	240.00
Martin Park	\$	50.00	\$	100.00
Sarvis Park	\$	150.00	\$	300.00
Wilkins Park	\$	20.00	\$	40.00
<b>ZONE 1 (Northwest) Total</b>	<b>\$</b>	<b>1,440.00</b>	<b>\$</b>	<b>2,880.00</b>
<b>ZONE 2 (West)</b>				
Cronin Derby Downs	\$	140.00	\$	280.00
Dort Park	\$	40.00	\$	80.00
Dougherty Park	\$	10.00	\$	20.00
Durant Park	\$	40.00	\$	80.00
Eldorado Vista Park	\$	80.00	\$	160.00
Genesee Valley Trail Margins	\$	20.00	\$	40.00

Gerholz Park	\$	30.00	\$	60.00
Hardenbrook Park	\$	50.00	\$	100.00
Mann Hall Park	\$	20.00	\$	40.00
McCailum Park	\$	15.00	\$	30.00
Metawanenee Park	\$	15.00	\$	30.00
Oak Park	\$	120.00	\$	240.00
Ramona Park	\$	15.00	\$	30.00
Sarginson Park	\$	60.00	\$	120.00
<b>ZONE 2 (West) Total</b>	\$	<b>655.00</b>	\$	<b>1,310.00</b>
<b>ZONE 3 (East)</b>				
Bundy Park	\$	15.00	\$	30.00
Amos Park	\$	7.50	\$	15.00
Avondale Cemetery	\$	225.00	\$	450.00
Cook Park	\$	225.00	\$	450.00
Delaware Park	\$	7.50	\$	15.00
Kearsley Park	\$	450.00	\$	900.00
Longway Park	\$	400.00	\$	800.00
Polk Park	\$	7.50	\$	15.00
Rollingwood	\$	125.00	\$	250.00
Whaley Park	\$	450.00	\$	900.00
<b>ZONE 3 (East) Total</b>	\$	<b>1,912.50</b>	\$	<b>3,825.00</b>
<b>ZONE 4 (Southeast)</b>				
Aldrich Park	\$	35.00	\$	70.00
Atherton Park	\$	135.00	\$	270.00
Burroughs Park	\$	150.00	\$	300.00
Farnumwood Park	\$	150.00	\$	300.00
Pierce Park	\$	30.00	\$	60.00
Windiate Park	\$	140.00	\$	280.00
Woodlawn Park	\$	75.00	\$	150.00
<b>ZONE 4 (Southeast) Total</b>	\$	<b>715.00</b>	\$	<b>1,430.00</b>
<b>ZONE 6 (Municipal Buildings)</b>				
City Hall & Fire Station #1	\$	100.00	\$	200.00
Fire Station #3	\$	15.00	\$	30.00
Fire Station #5	\$	5.00	\$	10.00
Fire Station #8	\$	15.00	\$	30.00
Fire Station #6	\$	5.00	\$	10.00
<b>ZONE 6 (Municipal Buildings) Total</b>	\$	<b>140.00</b>	\$	<b>280.00</b>

**ZONE 8 ( Street Triangles)**

12th/Grand Traverse	\$	5.00	\$	10.00
8th & 9th Corners and Triangles	\$	5.00	\$	10.00
Atherton Triangle	\$	2.50	\$	5.00
Beech/Wellington/Church	\$	2.50	\$	5.00
Beecher Triangle	\$	5.00	\$	10.00
Broadway Blvd	\$	40.00	\$	80.00
Burr Blvd	\$	20.00	\$	40.00
Cadillac Triangle	\$	2.50	\$	5.00
Chavez/Kearsley Park Triangle	\$	2.50	\$	5.00
Chester Simmons Triangle	\$	35.00	\$	70.00
Chevrolet Medians	\$	70.00	\$	140.00
Chevrolet Blvd	\$	70.00	\$	140.00
Chicago Triangles	\$	5.00	\$	10.00
	\$	2.50	\$	5.00
	\$	2.50	\$	5.00
Civic Park Triangles	\$	5.00	\$	10.00
	\$	5.00	\$	10.00
Colorado Triangle	\$	2.50	\$	5.00
Commonwealth Triangles	\$	25.00	\$	50.00
	\$	5.00	\$	10.00
	\$	5.00	\$	10.00
Davison/Lewis Triangle	\$	5.00	\$	10.00
Dayton Blvd	\$	40.00	\$	80.00
Dayton Triangles	\$	5.00	\$	10.00
Dort/Leith	\$	20.00	\$	40.00
Dupont Blvd	\$	40.00	\$	80.00
E. Court & 5th, Lapper & 5th Triangles	\$	40.00	\$	80.00
East Lawn Triangles	\$	5.00	\$	10.00
Fenton/Atherton Triangle	\$	2.50	\$	5.00
Forest Hill Blvd	\$	40.00	\$	80.00
Grand Traverse Triangle	\$	20.00	\$	40.00
Hamilton Blvd	\$	60.00	\$	120.00
Hamilton Triangle	\$	40.00	\$	80.00
Hammerburg Triangle	\$	2.50	\$	5.00
James P Cole Blvd	\$	100.00	\$	200.00
James P Cole Triangle	\$	2.50	\$	5.00
Kearsley Park Triangle	\$	2.50	\$	5.00
Linsey Blvd	\$	10.00	\$	20.00
Lippincott Blvd	\$	40.00	\$	80.00
Longway Blvd and Triangles	\$	80.00	\$	160.00
	\$	2.50	\$	5.00
	\$	2.50	\$	5.00
Mackin/Dupont Triangle	\$	2.50	\$	5.00



Mott Park Triangles	\$	5.00	\$	10.00
	\$	2.50	\$	5.00
	\$	2.50	\$	5.00
North Street Medians	\$	20.00	\$	40.00
North/South Chavez	\$	20.00	\$	40.00
	\$	20.00	\$	40.00
Ogema Triangle	\$	2.50	\$	5.00
Paterson Medians	\$	20.00	\$	40.00
Perry Street Triangles	\$	20.00	\$	40.00
	\$	5.00	\$	10.00
Ramsey Triangle	\$	2.50	\$	5.00
Riverside Triangle	\$	40.00	\$	80.00
S. Saginaw Median	\$	10.00	\$	20.00
Saginaw/University	\$	2.50	\$	5.00
Saginaw/Atherton Triangle	\$	2.50	\$	5.00
Stevenson/5th Triangle	\$	5.00	\$	10.00
Triangle on Greenway and Welch	\$	10.00	\$	20.00
Victoria Triangle	\$	2.50	\$	5.00
Wyoming Triangle	\$	2.50	\$	5.00
Welch Medians	\$	10.00	\$	20.00
<b>ZONE 8 ( Street Triangles)</b>				
<b>Total</b>	<b>\$</b>	<b>1,085.00</b>	<b>\$</b>	<b>2,170.00</b>

The City of Flint reserves the right to remove assigned properties with 30 days prior notice.

**Severability:** In the event that any provision contained herein shall be determined by a court or administrative tribunal to be contrary to a provision of state or federal law or to be unenforceable for any reason, then, to the extent necessary and possible to render the remainder of this Agreement enforceable, such provision may be modified or severed by such court or administrative tribunal so as to, as nearly as possible, carry out the intention of the parties hereto, considering the purpose of the entire Agreement in relation to such provision. The invalidation of one or more terms of this contract shall not affect the validity of the remaining terms.

**Standards of Performance:** Contractor agrees to exercise independent judgment and to perform its duties under this contract in accordance with sound professional practices. The City is relying upon the professional reputation, experience, certification, and ability of Contractor. Contractor agrees that all of the obligations required by him under this Contract shall be performed by him or by others employed by him and working under his direction and control. The continued effectiveness of this contract during its term or any renewal term shall be contingent upon Contractor maintaining his certification in accordance with the requirements of State law.

Work shall be conducted with the utmost professionalism and care and shall include:

- Routine lawn mowing, trimming and edging are required to maintain a manicured, uniform, dense stand of turf during the entire mowing season. **Mowing blades shall be set between 2.5 and 3 inches.**
- All turf areas shall be completely mowed and left without clippings or rolled grass after each scheduled cut.
- All mowing shall be done with clean, freshly sharpened and properly adjusted rotary mulching/recycling or reel type mowing equipment.
- All play equipment, trees, buildings, fencing, light poles, downed limbs, pavilions and other obstacles shall be weed whipped and trimmed after each scheduled cut.
- Sidewalks, walkways, parking lots, and curb lines shall be trimmed/edged after each scheduled cut. All trimmings on parking lots, sidewalks, walkways, basketball/tennis courts, curb lines or other hard surfaces shall be eliminated by whatever means are available to the Contractor and at no expense to the City. Clippings shall not be blown into the street.
- Mowing direction shall be varied with each mowing to change the patterns of wear and cut. Mow no closer than 4" to trees or park equipment or other obstacles. Trimming shall be completed around trees, etc. so as to avoid damage.
- **If grass clippings left by the mowing lay on top of the grass and become unsightly the clippings shall be eliminated by whatever means are available to the Contractor and at no expense to the City. Clippings shall not be blown into the streets.**
- Normal, everyday litter shall be removed prior to mowing. The City of Flint shall be contacted immediately if large quantities of illegal dumped debris are present.
- Clippings and related mowing and maintenance waste from all walks, grounds cover beds, parking lots and drives, etc. shall be removed from the site before mowing is considered complete and before the Contractor leaves the job site. Contractor is responsible for proper, legal disposal of waste.
- Under no circumstances are areas with saturated soils to be mowed that will result in destruction of turf or the soil profile by mowing equipment. In the event of wet conditions, which prevent full service on the property, the City of Flint is to be notified.
- **Unless explicitly instructed in writing, wet areas, low-lying areas, heavily wooded areas, or areas of rough terrain are to be trimmed.**
- The City of Flint may make temporary signage available for the contractor to mark areas that are "too wet to mow" to provide communication to residents.

**Evaluation:**

Each contractor will be evaluated on a monthly basis to ensure proper performance of their work. Appendix A contains a sample of the evaluation standards for each property.

Contractor's performance will be reviewed every month to evaluate their performance based on standards in the RFP and contract. A total of 10 points are available for each property based on the criteria below. Scores of 0 to 5 will result in Unsatisfactory rating, 6 to 7 Needs Improvement, and 8 or above Satisfactory.

All property scores will be averaged into one monthly score, which will determine if the contractor's performance is Unsatisfactory, Needs Improvement, or Satisfactory.

A monthly average of Unsatisfactory twice over the season or Needs Improvement 5 times over the season will result in a formal Notice of Complaint by the City of Flint. Contractors will have 30 days to remedy the poor performance that resulted in Notice of Complaint. Failure to do so may be used as cause to terminate the contract with the vendor.

Property scores of Unsatisfactory for any one single property 3 times in one season will also result a formal Notice of Complaint by the City of Flint. Failure to remedy the poor performance at that property may be used as cause to terminate the contract with the vendor.

**Frequency of Mowing/Scheduling:**

Mowing will be conducted at the discretion of the City of Flint.

- Contractor shall be assigned properties to be maintained by the City of Flint.
- Mowing, trimming, edging and clipping removal shall occur approximately every 14 days or as scheduled by the City of Flint. Please see above for general standards of service.
- It is the City's intention to cut the grass at least 14 times between March and December. Up to 6 individual, optional cuts or special event cuts are available to be used if requested in writing by the City.
- Contractor may request an additional cut, double cut, or special event cut, however, that work is to be completed with expressed written verification and approval of the City of Flint.
- Contractor will provide the City of Flint a weekly schedule as to which day of the week each property shall be mowed. The City of Flint shall be alerted by e-mail if weather delays the mowing, or changes to the schedule are requested.
- It is the City will mow each property 14 times per a season. No additional mowing shall occur on a property unless special event mows are requested by the City of Flint and/or double cuts are requested by the vendor. Please see below for information on double cuts or special event requests.
- It is the City's intention that parks will be cut at least 6 to 8 times prior to June 30<sup>th</sup>, 2018, though work is weather dependent and to be done at the City's desecration.
- It is the City's intention that parks will be cut 8 to 12 times after June 30<sup>th</sup>, 2018, though work is weather dependent and to be done at the City's desecration.
- While the City does not guarantee any minimum amount of work, the Contract expresses acknowledges that payment is not to exceed any amount above \$120,600.00.
- If the City experiences periods of extreme rain, heat or drought, a City representative will notify selected contractor to authorize the frequency of mowing.

**Special Events:**

At times the City of Flint may contact the contractor to perform a one time off schedule mow for a special event. Requests from the City will be made with at least five days prior to the special event. Special event cuts (also known as optional cuts) are to be billed to the City at the single cut rate.

**Double Cuts:**

At times the contractor may feel as though multiple cuts are necessary to meet contract standards due to high grass conditions. In this event the contractor may request a double cut. Double cuts shall only be conducted with expressed written/e-mailed consent of the City of Flint. Contractors may provide a double cut mowing price in their proposals.

**Communication:**

Contractors are required to contact assigned City of Flint representative by e-mail by noon every Monday on a weekly basis to provide an update on mowing completed the week before and an estimated schedule of work to be conducted over the next week. Any changes from the previous week's schedule should be noted and any problems or interruptions with service should be noted. Monthly evaluations from the City of Flint will be emailed to contractor's assigned representatives by the 1<sup>st</sup> of every month after work has begun.

**Notice to Proceed:**

No work shall commence without the expressed consent of the City of Flint. Each contractor is requested to attend a pre-service meeting to discuss services to be provided.

**Subcontracting:** No subcontract work, if permitted by the City, shall be started prior to the written approval of the subcontractor by the City. The City reserves the right to accept or reject any subcontractor.

**Termination:** This contract may be terminated by either party hereto by submitting a notice of termination to the other party. Such notice shall be in writing and shall be effective 30 days from the date it is submitted unless otherwise agreed to by the parties hereto. Contractor, upon receiving such notice and prorated payment upon termination of this contract shall give to the City all pertinent records, data, and information created up to the date of termination to which the City, under the terms of this contract, is entitled.

**Time of Performance:** Contractor's services shall commence immediately upon receipt of the notice to proceed and shall be carried out forthwith and without reasonable delay.

**Union Compliance:** Contractor agrees to comply with all regulations and requirements of any national or local union(s) that may have jurisdiction over any of the materials, facilities, services, or personnel to be furnished by the City. However, this provision does not apply if its application would violate Public Act 98 of 2011.

**Waiver:** Failure of the City to insist upon strict compliance with any of the terms, covenants, or conditions of this Agreement shall not be deemed a waiver of any term, covenant, or condition. Any waiver or relinquishment of any right or power hereunder at any one or more times shall not be deemed a waiver or relinquishment of that right or power at any other time.

**Whole Agreement:** This written agreement and the documents cited herein embody the entire agreement between the parties. Any additions, deletions or modifications hereto must be in writing and signed by both parties.

**List of Appendixes:**

**Appendix A: Mowing Evaluation**

**Appendix B: Contractor Bid Submission**

{Signature Page Follows}

IN WITNESS WHEREOF, the parties have executed this contract this March 27, 2018.

of (D)

CONTRACTOR:  
[Signature]  
Print Name: Jason Bagel  
Its Owner

WITNESS(ES):  
Mohamed Ali  
Print Name: (D)

CITY OF FLINT, a Michigan Municipal Corp.

[Signature]  
Dr. Karen Weaver, Mayor

APPROVED AS TO FORM:  
[Signature]  
Angela Wheeler, Chief Legal Officer

APPENDIX A: CITY OF FLINT MOWING MONTHLY PERFORMANCE EVALUATION

Contractor: \_\_\_\_\_ Rating: Unsatisfactory Needs Improvement  
Satisfactory

Property: \_\_\_\_\_ Date Scheduled for Service: \_\_\_\_\_ Date Evaluated: \_\_\_\_\_

**Monthly Mowing Performance Evaluation:**

Contractor's performance will be reviewed every month to evaluate their performance based on standards in the RFP and contract. A total of 10 points are available for each property based on the criteria below. Scores of 0 to 5 will result in an Unsatisfactory rating, 6 to 7 means Needs Improvement, and 8 or above is Satisfactory.

All property scores will be averaged into one monthly score, which will determine if the contractor's performance is Unsatisfactory, Needs Improvement, or Satisfactory.

A monthly average of Unsatisfactory twice over the season or Needs Improvement 5 times over the season will result in a formal Notice of Complaint by the City of Flint. Contractors will have 30 days to remedy the poor performance. Failure to do so may be used as cause to terminate the contract with the vendor.

Property scores of Unsatisfactory for any one single property 3 times in one season will also result a formal Notice of Complaint by the City of Flint. Failure to remedy the poor performance at that property may be used as cause to terminate the contract with the vendor.

**Evaluation Criteria:**

- All turf grass areas mowed evenly per schedule and contract standards (3 points)
- Communication of weekly schedules and monthly invoicing completed as required (1)
- All turf areas are free of heavy clippings or rolled grass (1)
- All fence lines, trees, equipment, buildings, picnic areas or other obstructions trimmed/edged (1)
- All inaccessible areas by mower must be trimmed with no high grass present (1)
- All parking lots, sidewalks, walkways, basketball/tennis courts, curb lines or other hard surfaces trimmed/edged (1)
- All clippings or debris removed from streets, sidewalks, courts or other hard surfaces (1)
- No wheel ruts, turf scrapping, damage to trees or equipment noticed (1)

**Notes:**

Evaluator: \_\_\_\_\_ Further action necessary? \_\_\_\_\_

Boyd's Lawn and Landscaping

5103 W Coldwater Rd.

Flint, MI

810-479-5616

Boyd's Lawn and Landscaping is a veteran owned individual small business and has been in business since 2011.

We have done business with the City of Flint DPW for weed abatement since 2011, and cut the city's parks for the past two years and have over 10 years of experience cutting the parks while working with J&M tree service as the foreman, GTJ Consulting performing work on properties for Fannie Mae.

We have cut the parks for the City of Flint for the last 2 years  
We have been cutting weed abatement for the City of Flint since 2011

I personally have been performing this type of work for 26 years and have been cutting and trimming the parks since 2003, while working in other capacities before starting this company.

We fully understand the grass cutting criteria set forth in this contract and have the ability to perform them in a timely and efficient manner.

We own 7 Zero turn mowers and are able to cut up to 150 acres of grass each day, totaling 750 acres in a 5 day window.

61" Scag Turf Tiger II  
2- 60" Exmark Zero Turn  
2- 60" Toro Zero turns  
52" Scag Tiger Cat  
52" Kubota

Chris Jens GTJ Consulting, 586-293 8200  
Mike Patterson Guardian Asset Management 908-313-2696  
Betty Wideman City of Flint DPW, 810-766-7343

Thank you for allowing us to provide you with the best service possible.

Jason Boyd

Owner



# CERTIFICATE OF LIABILITY INSURANCE

DATE (MM/DD/YYYY)  
10/22/2017

THIS CERTIFICATE IS ISSUED AS A MATTER OF INFORMATION ONLY AND CONFERS NO RIGHTS UPON THE CERTIFICATE HOLDER. THIS CERTIFICATE DOES NOT AFFIRMATIVELY OR NEGATIVELY AMEND, EXTEND OR ALTER THE COVERAGE AFFORDED BY THE POLICIES BELOW. THIS CERTIFICATE OF INSURANCE DOES NOT CONSTITUTE A CONTRACT BETWEEN THE ISSUING INSURER(S), AUTHORIZED REPRESENTATIVE OR PRODUCER, AND THE CERTIFICATE HOLDER.

IMPORTANT: If the certificate holder is an ADDITIONAL INSURED, the policy(ies) must be endorsed. If SUBROGATION IS WAIVED, subject to the terms and conditions of the policy, certain policies may require an endorsement. A statement on this certificate does not confer rights to the certificate holder in lieu of such endorsement(s).

	Producer Insureon (WIN Insurance Holdings LLC.) 1101 Central Express South, Suite 250 Allen, TX 75013	CONTACT NAME: PHONE: FAX: E-MAIL: ADDRESS:	E00-668-1984 (877) 826-9087
	INSURER(S) ENDORSING COVERAGE		NAIC # 19879
INSURED Boyd's lawn and landscaping 1093 Corydon dr Mount Morris, MI 48858		INSURER A: Security National Insurance Company INSURER B: INSURER C: INSURER D: INSURER E: INSURER F:	

COVERAGES: CERTIFICATE NUMBER: REVISION NUMBER:

THIS IS TO CERTIFY THAT THE POLICIES OF INSURANCE LISTED BELOW HAVE BEEN ISSUED TO THE INSURED NAMED ABOVE FOR THE POLICY PERIOD INDICATED. NOTWITHSTANDING ANY REQUIREMENT, TERM OR CONDITION OF ANY CONTRACT OR OTHER DOCUMENT WITH RESPECT TO WHICH THIS CERTIFICATE MAY BE ISSUED OR MAY PERTAIN, THE INSURANCE AFFORDED BY THE POLICIES DESCRIBED HEREIN IS SUBJECT TO ALL THE TERMS, EXCLUSIONS AND CONDITIONS OF SUCH POLICIES. LIMITS SHOWN MAY HAVE BEEN REDUCED BY PAID CLAIMS.

DESCR LTR	TYPE OF INSURANCE	ADDITIONAL COV	POLICY NUMBER	POLICY EFF (MM/DD/YYYY)	POLICY EXP (MM/DD/YYYY)	LIMITS
A	<input checked="" type="checkbox"/> COMMERCIAL GENERAL LIABILITY <input type="checkbox"/> CLAIMS MADE <input checked="" type="checkbox"/> OCCUR GEN'L AGGREGATE LIMIT APPLIES PER <input checked="" type="checkbox"/> POLICY <input type="checkbox"/> PROJ. <input type="checkbox"/> LOC <input type="checkbox"/> OTHER	Yes	NA105914503	10/22/2017	10/22/2018	EACH OCCURRENCE \$ 1,000,000 DAMAGE TO RENTED PREMISES (EA OCCURRENCE) \$ 100,000 MED EXP (MTY, NON PERSON) \$ 5,000 PERSONAL & ADV BILIURY \$ 1,000,000 GENERAL AGGREGATE \$ 2,000,000 PRODUCTS - COMP/OP AGG \$ 2,000,000
	AUTOMOBILE LIABILITY <input type="checkbox"/> ANY AUTO <input type="checkbox"/> SCHEDULED AUTOS <input type="checkbox"/> ALL OWNED AUTOS <input type="checkbox"/> NONOWNED AUTOS <input type="checkbox"/> HIRED AUTOS					OCCURRED SOURCE LIMIT (EA ACCIDENT) \$ BODILY BILIURY (Per person) \$ BODILY BILIURY (Per accident) \$ PROPERTY DAMAGE (Per accident) \$
	UMBRELLA LIAB <input type="checkbox"/> OCCUR EXCESS LIAB <input type="checkbox"/> CLAIMS MADE					EACH OCCURRENCE \$ AGGREGATE \$
	WORKERS COMPENSATION AND EMPLOYERS LIABILITY ANY PROFESSIONAL PARTNERSHIP/EXECUTIVE OFFICER/DIRECTOR EXCLUSION? (Mandatory in MI) If yes, describe and DESCRIPTION OF OPERATIONS below					E.L. EACH ACCIDENT \$ E.L. DISEASE - EA EMPLOYEE \$ E.L. DISEASE - POLICY LIMIT \$

DESCRIPTION OF OPERATIONS / LOCATIONS / VEHICLES (ACORD 101, Additional Rater/Info Schedule, may be checked if more space is required)  
 The City of Flint and including all elected and appointed officials, all employees and volunteers, all boards, commissions and/or authorities and their board members, employees and volunteers, are named as Additional Insured as their interests may appear in regards to general liability and automobile liability

CERTIFICATE HOLDER City of Flint 1101 S. Saginaw St., 3rd Floor Flint, MI 48502	CANCELLATION SHOULD ANY OF THE ABOVE DESCRIBED POLICIES BE CANCELLED BEFORE THE EXPIRATION DATE THEREOF, NOTICE WILL BE DELIVERED IN ACCORDANCE WITH THE POLICY PROVISIONS. AUTHORIZED REPRESENTATIVE _____
--	--





RESOLUTION NO.: 210253

PRESENTED: JUN - 6 2021

ADOPTED: \_\_\_\_\_

BID # 19-008

BY THE CITY ADMINISTRATOR:

**RESOLUTION TO AIS CONSTRUCTION EQUIPMENT FOR VOGELE PAVER AND HAMM ROLLER**

WHEREAS, the Street Maintenance division recommended purchase of a Vogele Paver and a Hamm Roller from the lowest bidder AIS Construction Equipment, 5655 Pontiac Trail, New Hudson, MI as part of a cost to lease agreement through the Houston-Galveston Area Council national contract #SM10-16 for an annual amount not to exceed \$125,266.56 for FY2019 to FY2022, and an additional \$11,201.00 in FY2022 if the City purchases the equipment at the end of the lease.

Account Number	Account Name	Amount
202-449.201-977.000	Equipment (paver)	\$49,060.30
203-449.201-977.000	Equipment (paver)	49,060.29
202-449.201-977.000	Equipment (roller)	13,572.98
203-449.201-977.000	Equipment (roller)	13,572.97
	<b>FY2021 GRAND TOTAL</b>	<b>\$125,266.54</b>

IT IS RESOLVED, that the appropriate City Officials are authorized to do all things necessary to enter into the third year of the contract with AIS Construction Equipment to lease a Vogele Paver and Hamm Roller for FY2021 for the amount of \$125,266.54.

APPROVED AS TO FORM:

Angela Wheeler  
Angela Wheeler (May 26, 2021 14:01 EDT)  
**Angela Wheeler, Chief Legal Officer**

APPROVED AS TO FINANCE:

Shelbi Frayer  
shelbi frayer (May 27, 2021 15:07 EDT)  
**Shelbi Frayer, Chief Financial Officer**

FOR THE CITY OF FLINT:

Clyde D Edwards  
CLYDE D EDWARDS (May 28, 2021 11:44 EDT)  
**Clyde Edwards, City Administrator**

APPROVED BY CITY COUNCIL:

\_\_\_\_\_  
**Kate Fields, City Council President**

APPROVED AS TO PURCHASING:

Jennifer Ryan  
Jennifer Ryan (May 26, 2021 13:25 EDT)  
**Jenn Ryan, Deputy Finance Director**



CITY OF FLINT

STAFF REVIEW FORM

TODAY'S DATE: June 2, 2021

BID/PROPOSAL# 19-008

AGENDA ITEM TITLE: Lease agreement for a paver and roller

PREPARED BY Kathryn Neumann for Michael Brown, Director of Public Works

VENDOR NAME: AIS Construction Equipment/Deere Credit

BACKGROUND/SUMMARY OF PROPOSED ACTION:

On May 28, 2019, Flint City Council authorized the Department of Purchases & Supplies to issue a purchase order to lease to own a new paver and roller for the Street Maintenance Division. This is year three and FY22 will be year four. The City intends to buy the equipment at the end of the lease.

FINANCIAL IMPLICATIONS: There is money in the accounts listed below

BUDGETED EXPENDITURE? YES [X] NO [ ] IF NO, PLEASE EXPLAIN:

Table with 5 columns: Dept., Name of Account, Account Number, Grant Code, Amount. Rows include Major Street Fund, Local Street Fund, and FY21 GRAND TOTAL.

PRE-ENCUMBERED? YES [X] NO [ ] REQUISITION NO: 210004601, 210004598

ACCOUNTING APPROVAL: Kirstie Troup Date: 6/2/21

WILL YOUR DEPARTMENT NEED A CONTRACT? YES [ ] NO [X] (If yes, please indicate how many years for the contract)

OTHER IMPLICATIONS (i.e., collective bargaining): None

STAFF RECOMMENDATION: (PLEASE SELECT): [X] APPROVED [ ] NOT APPROVED

DEPARTMENT HEAD SIGNATURE: [Signature] (Michael J. Brown, Director of Public Works)

190191

(Bid #19000008)

SUBMISSION NO.: \_\_\_\_\_

PRESENTED: 5-22-19

ADOPTED: 5-28-2019

**RESOLUTION TO AIS CONSTRUCTION EQUIPMENT FOR THE PURCHASE OF A  
VOGELE PAVER AND A HAMM ROLLER**

BY THE CITY ADMINISTRATOR:

**RESOLUTION**

The Street Maintenance Division is requesting the issuance of a purchase order to purchase a Vogele Paver and a Hamm Roller; and

AIS Construction Equipment, 5655 Pontiac Trail, New Hudson, MI was the lowest vendor to submit a price and has submitted a cost to lease to purchase said equipment through the Houston-Galveston Area Council national contract #SM10-16. Funding for said services will come from the following accounts: 202-449.201-977.000 (\$62,633.28), 203-449.201-977.000 (\$62,633.28); and

IT IS RESOLVED, that the Department of Purchases and Supplies, upon City Council's approval, is hereby authorized to issue a purchase order to AIS Construction Equipment for the lease/purchase of a Vogele Paver and a Hamm Roller in an annual amount not to exceed \$125,266.56 and an aggregate amount of \$626,332.80. If the City decides to purchase said equipment at the end of the lease, the additional purchase cost will be \$11,201.00 for a total purchase of \$637,533.80. (Local Street Fund, Major Street Fund) \$125,266.56 FY19, \$125,266.56 FY20, \$125,266.56 FY21, \$125,266.56 FY22. If final purchase is made, an additional \$11,201.00 will be in FY22.

APPROVED PURCHASING DEPT.:

  
Joyce McClane  
Purchasing Manager

APPROVED AS TO FINANCE

  
James A. Lewis  
Deputy Finance Director

APPROVED AS TO FORM

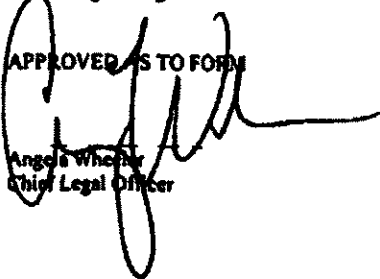
  
Angela Wheeler  
Chief Legal Officer

  
Steve Branch, City Administrator

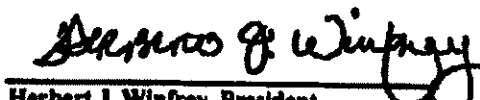
  
Herbert J. Winfrey, President  
City Council



RESOLUTION NO.: 210255

PRESENTED: JUN - 6 2021

ADOPTED: \_\_\_\_\_

BY THE CITY ADMINISTRATOR:

**RESOLUTION TO LASERCOM LLC FOR ADDITIONAL MAILING SERVICES**

WHEREAS, the Customer Service Center (CSC) uses Lasercom for mailing services, including printing, sorting, and mailing of water bills, water shutoff notices, and property taxes. The CSC recommends to extend the contract with Lasercom to cover postage for additional mailing of City property tax bills.

Account Number	Account Name	Amount
101-253.200-902.000	Supplies	\$24,500.000
	<b>FY2021 GRAND TOTAL</b>	<b>\$24,500.00</b>

IT IS RESOLVED, that the appropriate City Officials are authorized to do all things necessary to enter into change order #1 to the contract with Lasercom LLC to provide additional postage for the mailing of City property tax bills for FY2021 for the amount of \$24,500.00 and a contract total amount of \$173,590.00 under the same terms and conditions.

APPROVED AS TO FORM:

*Angela Wheeler*  
Angela Wheeler (May 24, 2021 16:12 EDT)  
**Angela Wheeler, Chief Legal Officer**

APPROVED AS TO FINANCE:

*shelbi frayer*  
shelbi frayer (May 25, 2021 15:42 EDT)  
**Shelbi Frayer, Chief Financial Officer**

FOR THE CITY OF FLINT:

*CLYDE D EDWARDS*  
CLYDE D EDWARDS (May 28, 2021 11:41 EDT)  
**Clyde Edwards, City Administrator**

APPROVED BY CITY COUNCIL:

\_\_\_\_\_  
**Kate Fields, City Council President**

APPROVED AS TO PURCHASING:

*Jennifer Ryan*  
Jennifer Ryan (May 24, 2021 14:46 EDT)  
**Jenn Ryan, Deputy Finance Director**



# CITY OF FLINT

## RESOLUTION STAFF REVIEW FORM

**TODAY'S DATE:** 5/14/2021

**BID/PROPOSAL#**

**AGENDA ITEM TITLE:** LASERCOM

**PREPARED BY:** Patrice Ellison, Admin Clerk, Finance/Customer Service Center  
*(Please type name and Department)*

**VENDOR NAME:** LASERCOM

**BACKGROUND/SUMMARY OF PROPOSED ACTION:**

The purpose of this resolution is to get approval for Lasercom, LLC to pay for postage for additional mailing of City of Flint property tax bills.

**FINANCIAL IMPLICATIONS:** \$24,500.00

**BUDGETED EXPENDITURE?** YES  NO  **IF NO, PLEASE EXPLAIN:**

Dept.	Name of Account	Account Number	Grant Code	Amount
FIN/ CSC	Customer Services- Treasury Operation - Postage	101-253.200.902.000		\$24,500.00

**PRE-ENCUMBERED?** YES  NO  **REQUISITION NO:** 210004550



# CITY OF FLINT

ACCOUNTING APPROVAL: \_\_\_\_\_ Date: \_\_\_\_\_

WILL YOUR DEPARTMENT NEED A CONTRACT? YES  NO   
*(If yes, please indicate how many years for the contract* YEARS

WHEN APPLICABLE, IF MORE THAN ONE (1) YEAR, PLEASE ESTIMATE TOTAL AMOUNT FOR EACH BUDGET YEAR: *(This will depend on the term of the bid proposal)*

BUDGET YEAR 1

BUDGET YEAR 2

BUDGET YEAR 3

OTHER IMPLICATIONS *(i.e., collective bargaining)*: None

STAFF RECOMMENDATION: *(PLEASE SELECT)*:  APPROVED  NOT APPROVED

DEPARTMENT HEAD SIGNATURE: *Amanda Trujillo*  
*(AMANDA TRUJILLO, CITY OF FLINT TREASURER)*

190416

(Proposal #20000516)

RESOLUTION NO. \_\_\_\_\_

PRESENTED: 10-9-19

ADOPTED: 10-14-2019

BY THE CITY ADMINISTRATOR:

**RESOLUTION TO LASERCOM, LLC FOR PRINTING, SORTING, MAILING OF WATER BILLS/SHUT OFF NOTICES AND PROPERTY TAX BILLS**

**RESOLUTION**

The Department of Purchases & Supplies has solicited proposals for Printing, Sorting, Mailing of Water Bills/Shut Off Notices and Property Tax Bills; and

Lasercom LLC, 2230 Elliot, Troy, Michigan was the responsive bidder from six solicitations for said requirements. This is to provide labor and equipment for sorting mailing of water bills shut off notices, property tax bills and postage as needed for three (3) fiscal years (2020 thru 2022) Funding for said services will come from the following accounts: 101-253.202-900.000 (\$15,765.00); 101-253.203-900.000 (\$15,765.00); 101-253.202-729.000 (\$50,000.00); 101-253.203-729.000 (\$50,000.00); 101-253.200-900.000 (\$10,000.00); 101-253.200-729.000 (\$7,560.00);and

IT IS RESOLVED, that the Proper City Officials, upon City Councils approval, are hereby authorized to issue a purchase order and enter into a contract with Lasercom LLC for printing, sorting, mailing of water bills shut off notices, property tax and postage as needed for a three (3) year (2020 thru 2022) an aggregate amount for each year of \$149,090.00.

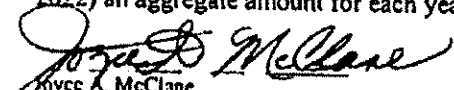
  
Joyce A. McClane  
Purchasing Manager

  
Tamar A. Lewis  
Deputy Finance Director

APPROVED AS TO FORM:  
  
Angela Wheeler  
Chief Legal Officer

  
Steve Branch, City Administrator

  
Herbert J. Winfrey, Council President



CITY OF FLINT

RESOLUTION STAFF REVIEW FORM

TODAY'S DATE: 6/5/2020

BID/PROPOSAL# 20-516

AGENDA ITEM TITLE: LASERCOM

PREPARED BY PATRICE ELLISON, ADMIN CLERK, FINANCE/CUSTOMER SERVICE CENTER
(Please type name and Department)

VENDOR NAME: LASERCOM

BACKGROUND/SUMMARY OF PROPOSED ACTION:

THE PURPOSE OF THIS RESOLUTION IS TO GET APPROVAL FOR LASERCOM, LLC TO PROVIDE LABOR AND EQUIPMENT FOR MONTHLY PRINTING, SORTING AND MAILING OF WATER BILLS/SHUTOFF NOTICES AND PROPERTY TAX BILLS FOR 3 FISCAL YEARS, 2020-2022, POSTAGE AS NEEDED.

FINANCIAL IMPLICATIONS: 117,270.00

BUDGETED EXPENDITURE? YES [X] NO [ ] IF NO, PLEASE EXPLAIN:

Table with 5 columns: Dept., Name of Account, Account Number, Grant Code, Amount. It lists various account numbers and amounts for printing and postage services.





# CITY OF FLINT

	Treasury Operation – Printing & Publication	101-253.200-900.000		7,560.00
	Treasury Operation - Postage	101-253.200.729.000		Postage as needed
	<b>FY 2021</b>			<b>\$39,090.00</b>
FIN/ CSC	Water Collection Printing & Publishing	101-253.202-900.000		15,765.00
	Sewer Collection Printing & Publishing	101-253.203-900.000		15,765.00
	Water Collection - Postage	101-253.202-729.000		Postage as needed
	Sewer Collection - Postage	101-253.203-729.000		Postage as needed
	Treasury Operation – Printing & Publication	101-253.200-900.000		7,560.00
	Treasury Operation - Postage	101-253.200.729.000		Postage as needed
	<b>FY 2022</b>			<b>\$39,090.00</b>
		<b>FY20/22 GRAND TOTAL</b>		

PRE-ENCUMBERED? YES  NO  REQUISITION NO: 20-0003314

ACCOUNTING APPROVAL: \_\_\_\_\_ Date: \_\_\_\_\_

WILL YOUR DEPARTMENT NEED A CONTRACT? YES  NO

(If yes, please indicate how many years for the contract) 3 YEARS

WHEN APPLICABLE, IF MORE THAN ONE (1) YEAR, PLEASE ESTIMATE TOTAL AMOUNT FOR EACH BUDGET YEAR: (This will depend on the term of the bid proposal)

BUDGET YEAR 1 \$149,090.00

BUDGET YEAR 2 \$39,090.00, postage as needed

BUDGET YEAR 3 \$39,090.00, postage as needed

OTHER IMPLICATIONS (i.e., collective bargaining): None

STAFF RECOMMENDATION: (PLEASE SELECT):  APPROVED  NOT APPROVED



# CITY OF FLINT

---

DEPARTMENT HEAD SIGNATURE:

*Amanda Trujillo*

(AMANDA TRUJILLO, CITY OF FLINT TREASURER)

### BID ANALYSIS FORM

Interested vendors are to complete this document and submit as part of their bid packet.

#### Section A – Tax Bills

Item #	Description	Year 1 Award date – 6/30/20 (A)	Year 2 07/01/20-06/30/21 (B)	Year 3 07/01/21-06/30/22 (C)	Total – 3 Year (A + B + C)
1	Summer Property Tax Bill – Furnish as requested for the period through 6/30/16 the printing, sorting, and mailing of tax bill to include 4-part coupon, 1 for payment in full, and 1 for each installment with due dates of 7/31, 10/31, and 2/28, as outlined in specification of this bid. One mailing only that is received by citizens by 7/1 of each year. Vendor is to price for approximately 40,000 bills.	5400.00	5400.00	5400.00	16,200.00
2	Winter Property Tax Bill – Furnish as requested for the period through 6/30/20 the printing, sorting, and mailing of 2-part tax bill that is to be received by citizens by 12/1 with a bill reflecting a due date of 2/14. One mailing of approximately 40,000 bills.	4400.00	4400.00	4400.00	13,200.00
3	Grand Total – Item 1 + Item 2				29,400.00

#### Section B – Water Bills and Shutoff Notices

Item #	Description	Year 1 Award date – 6/30/20 (A)	Year 2 07/01/20-06/30/21 (B)	Year 3 07/01/21-06/30/22 (C)	Total – 3 Year (A + B + C)
1	Water Bills – Furnish as requested for the period through 6/30/16 printing, sorting, and mailing of water bill as outlined in specification of this bid. Approximately 40,000 bills sent out each month over 9 cycles. Vendor is to provide pricing to perform work on a monthly basis.	260.00 /mth. 31200	260.00 /mth. 31200	260.00 /mth. 31200	780.00 /mth. 93600

2	Shutoff Notices – Furnish as requested for the period through 6/30/20 printing, sorting, and mailing of shutoff notices on a weekly basis. Vendor is to provide pricing to perform work on a monthly basis based on sending out 500-2000 notices a week.	630.00 /mth. 7500	630.00 /mth. 7500	630.00 /mth. 7500	1890.00 /mth 22680 116280
3	Grand Total – Item 1 + Item 2				9690.00

**BID ANALYSIS FORM**

**Section 2.0**

Description	*(A) Cost to Print Valuation Change Notices (Approx. 47,000)	*(B) Cost to Print Personal Property Statements & Form 5076 Approx. 2,200	Total (A + B)
Year 1	3995.00	374.00	4369.00
Year 2	3995.00	374.00	4369.00
Year 3	3995.00	374.00	4369.00
			Total (1+2+3) 13,107.00

Quantities are not guaranteed. Vendors may propose and submit alternate or recommended variations of requirements that might afford cost savings to the City of Flint. If vendor elects to submit an alternative, it is suggested that vendor complete the bid analysis form and submit alternative on a separate form. Vendor must detail information concerning the alternate and send samples.

Quantities are not guaranteed. Vendors may propose and submit alternate or recommended variations of requirements that might afford cost savings to the City of Flint. If vendor elects to submit an alternative, it is suggested that vendor complete the bid analysis form and submit alternative on a separate form. Vendor must detail information concerning the alternate and send samples.

**THIS PAGE MUST BE COMPLETED AND INCLUDED WITH SUBMITTAL:**

The undersigned hereby certifies, on behalf of the respondent named in this Certification (the "Respondent"), that the information provided in this offer submitted to the City of Flint is accurate and complete, and that I am duly authorized to submit same. I hereby certify that the Respondent has reviewed all documents and requirements included in this offer and accept its terms and conditions.

Cash Discounts will be computed from the date of receipt of invoice. Prices firm unless stated otherwise by bidder. Delivery can be made in <sup>15</sup> ~~30~~ days ARO (after receipt of order).

Payment Terms: 1/30 Delivery Dest.: TBD Fed. ID #: \_\_\_\_\_  
(All Freight Terms are considered F.O.B., Prepaid unless otherwise noted by seller)

COMPANY NAME Lasercor LLC  
(Respondent):  
(Printed) David Grudzinski  
ADDRESS : 2230 Elliot  
CITY/STATE/ZIP : Troy MI 48083  
PHONE : 248-585-7800 FAX: \_\_\_\_\_  
EMAIL : dave@lasercorllc.com  
PRINT NAME : David Grudzinski  
(Authorized Representative)  
SIGNED : David Grudzinski DATE: 5-23-19  
(Authorized Representative)

Please submit original documents plus one copy.

New vendors are required to complete and submit an IRS W-9 Form and Vendor ACH Form with the City of Flint. Link is available at <https://www.cityofflint.com/finance/accounts-payable-department/>

Bid results may be viewed next business day online at <https://www.cityofflint.com/finance/purchasing/results/> under "bid results".



PROPOSAL# 21000608

RESOLUTION NO.: 210256

PRESENTED: JUN - 6 2021

ADOPTED: \_\_\_\_\_

BY THE CITY ADMINISTRATOR:

**RESOLUTION TO RNA FACILITIES MANAGEMENT FOR JANITORIAL SERVICES**

WHEREAS, the Facilities division solicited for janitorial services for City buildings. The Facilities division recommends the lowest qualified bidder RNA Facilities Management in the amount of \$176,000 for FY2022, \$180,000 for FY2023, and \$186,000 for FY2024, totaling \$542,000. The differences between RNA Facilities Management’s annual proposed costs and the amounts requested represent the floor stripping and waxing services and emergency janitorial services.

Account Number	Account Name	Amount
101-753.200-801.000	Professional Services	\$138,560.00
202-449.201-801.000	Professional Services	18,720.00
590-540.100-801.000	Professional Services	9,360.00
591-540.100-801.000	Professional Services	9,360.00
	<b>FY2022 GRAND TOTAL</b>	<b>\$176,000.00</b>

IT IS RESOLVED, that the appropriate City Officials are authorized to do all things necessary to enter into a contract with RNA Facilities Management to provide janitorial services for FY2022, pending budget adoption, for the amount of \$176,000.00.

APPROVED AS TO FORM:

Angela Wheeler  
Angela Wheeler (May 27, 2021 17:55 EDT)  
Angela Wheeler, Chief Legal Officer

APPROVED AS TO FINANCE:

Shelbi Frayer  
shelbi Frayer (May 28, 2021 12:28 EDT)  
Shelbi Frayer, Chief Financial Officer

FOR THE CITY OF FLINT:

Clyde Edwards  
Clyde D Edwards (May 28, 2021 14:23 EDT)  
Clyde Edwards, City Administrator

APPROVED BY CITY COUNCIL:

\_\_\_\_\_  
Kate Fields, City Council President

APPROVED AS TO PURCHASING:

Jennifer Ryan  
Jennifer Ryan (May 27, 2021 15:49 EDT)  
Jenn Ryan, Deputy Finance Director



CITY OF FLINT

STAFF REVIEW FORM

TODAY'S DATE: May 27, 2021

BID/PROPOSAL# 21-608

AGENDA ITEM TITLE: Janitorial services

PREPARED BY: Kathryn Neumann for Jennifer Ryan, Deputy Finance Director

VENDOR NAME: RNA Facilities Management

BACKGROUND/SUMMARY OF PROPOSED ACTION:

Janitorial services were contracted out around 2012. The current contract expires June 30, 2021 and sealed proposals were solicited. Fourteen bids were received and a janitorial services committee reviewed the bids. Some vendors did not meet the bid specifications; others did not attend the mandatory pre-bid meeting. The committee interviewed the three lowest bidders that met the criteria and picked the lowest responsive bidder, RNA Facilities Management. RNA is a national company and they were the low bidder for the first year, and then the yearly cost went up by 3% for the following two years. They also included chemicals in their bid response (no other vendor did so), which will reduce the amount the Maintenance Division spends on janitorial supplies. Last year, the Maintenance Division spent approximately \$4,386 buying chemicals, which makes up the difference in price for the second year between RNA and the next lowest bidder (CITI Building Services).

FINANCIAL IMPLICATIONS: There is money in the accounts listed below

BUDGETED EXPENDITURE? YES [X] NO [ ] IF NO, PLEASE EXPLAIN:

Table with 5 columns: Dept., Name of Account, Account Number, Grant Code, Amount. Rows include General Fund, Major Street Fund, Sewer Fund, Water Fund, and a total row for FY21 GRAND TOTAL.

PRE-ENCUMBERED? YES [X] NO [ ] REQUISITION NO: 210004389, 210004176

ACCOUNTING APPROVAL: \_\_\_\_\_ Date: \_\_\_\_\_

WILL YOUR DEPARTMENT NEED A CONTRACT? YES [X] NO [ ]

(If yes, please indicate how many years for the contract) 3 YEARS





## CITY OF FLINT

---

**OTHER IMPLICATIONS (i.e., collective bargaining):** None

**STAFF RECOMMENDATION: (PLEASE SELECT):**  **APPROVED**  **NOT APPROVED**

**DEPARTMENT HEAD SIGNATURE:** lee osborne  
lee osborne (May 27, 2021 16:40 EDT)

*(Lee Osborne, Facilities Maintenance Supervisor)*

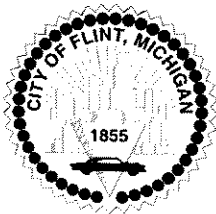

# CITY OF FLINT

## Department of Public Works & Utilities

**Sheldon A. Neeley**  
Mayor

**Michael J. Brown**  
Director

May 26, 2021

**TO:** Jennifer Ryan  
Deputy Finance Director

**FROM:** Lee Osborne  
Facilities Maintenance Supervisor

**SUBJECT:** RECOMMENDATION FOR JANITORIAL SERVICES, PROPOSAL 21-608

A committee was formed for the janitorial services bids and we met three times to review the bids. The committee narrowed the fourteen bids received down to the three low bidders that met the criteria and then met in person with each of the companies. RNA Facilities Management was the lowest responsive bidder and I am recommending a three year contract in the amount not to exceed \$176,000 for year 1, \$180,000 for year 2 and \$186,000 for year three, for a three year aggregate of \$542,000.00. The extra money added each year will be for floor stripping and waxing (which is not included) and any emergencies that arise in which janitors will be needed (such as a flood in the Police Dept.).

If you have any questions or concerns, feel free to give me a call at 810 691-6786.

SEALED PROPOSALS RECEIVED IN THE PURCHASING DEPARTMENT

ON MAY 5, 2021

PROPOSAL #21000608

<b>RNA FACILITIES MGMT*</b> 717 W. Ellsworth Rd. Ann Arbor, MI	<b>CITI BUILDING SERVICES</b> 1307 E. Allen Dr. Troy, MI	<b>EG WORKFORCE SOLUTIONS</b> 4625 Beckley Rd. Battle Creek, MI	<b>MASTER MAINTENANCE</b> 2701 I-94 Service Dr. Ypsilanti, MI	<b>A &amp; J JANITORIAL SERVICES</b> 1401 Sunnyside Ave. Flint, MI
\$ 172,368.00 Year 1	\$ 174,720.00 Year 1	\$ 185,932.00 Year 1	\$ 253,812.00 Year 1	\$ 287,160.00 Year 1
\$ 177,539.04 Year 2	\$ 174,720.00 Year 2	\$ 185,932.00 Year 2	\$ 253,812.00 Year 2	\$ 287,160.00 Year 2
\$ 182,865.21 Year 3	\$ 174,720.00 Year 3	\$ 185,932.00 Year 3	\$ 253,812.00 Year 3	\$ 287,160.00 Year 3
Local Preference \$ 184,433.76				

<b>CSM SERVICES</b> 3536 Highland Dr. Hudsonville, MI	<b>LOCKETT ENTERPRISES</b> 607 E. 2 <sup>ND</sup> Ave. Flint, MI	<b>PROFESSIONAL BLDG. SERVICES</b> 119 S. Main St. Frankenmuth, MI	<b>LGC GLOBAL</b> 7310 Woodward Ave. Detroit, MI	<b>MI MERCHANTS</b> PO BOX 91 Mt. Morris, MI
\$ 291,777.72 Year 1	\$ 295,848.00 Year 1	\$ 154,992.00 Year 1	\$ 158,991.12 Year 1	\$ 201,816.00
\$ 291,777.72 Year 2	\$ 295,848.00 Year 2	Did not meet bid specs	Did not meet bid specs	Did not meet bid specs
\$ 291,777.72 Year 3	\$ 295,848.00 Year 3			

<b>GREAT LAKES FACILITY MGMT.</b> 1428 W. Court St. Flint, MI	<b>JUS' US COMMERCIAL CLEANING</b> 500 Fiske Dr. Detroit, MI	<b>CLEAN NET OF GREATER MI</b> 30665 Northwestern Hwy Farmington Hills, MI	<b>MI BUILDING CLEANING</b> No address on paperwork	
\$ 171,924.00 Year 1	Did not attend the mandatory pre-bid meeting	Did not attend the mandatory pre-bid meeting	Did not attend the mandatory pre-bid meeting	
Did not meet bid specs				

\* Price included all chemicals, which none of the other companies included that cost. Last year Maintenance spent \$4,386 buying chemicals and that was during a pandemic with many departments working from home. This will save the City of Flint money on the yearly janitorial supplies purchase order.

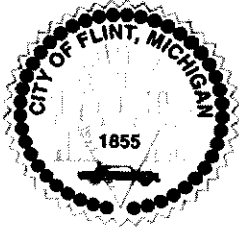

**City of Flint**  
**Department of Finance**  
**Division of Purchases & Supplies**

---

Sheldon A. Neeley

May 10, 2021

**TO:** Lee Osborne  
**FROM:** Joyce A. McClane  
Purchasing Manager  
**SUBJECT:** SEALED BIDS

Attached are fourteen (14) bids that were received for **PROPOSAL #21000608 – JANITORIAL SERVICES – 3 YEARS WITH OPTION TO EXTEND 2 YEARS**. Enclosed are copies for your file. **Bid Due Date: 5/5/21. Enclosed is a spreadsheet.**

Your staff review and recommendation form is needed as soon as possible. **Please use the new fillable form.** This form is to be used for your staff review.

A staff review must be completed for **ALL Bids/Proposals**. Please let me know if you need a copy of the fillable form.

**Please note:** If your project is being funded by any grants issued by the federal government, you must go to:  
<https://www.dol.gov/ofccp/regs/compliance/preaward/debarlst.htm> to ensure that the selected vendor has not been debarred.

**PLEASE NOTE:**

Results may be viewed next business day online **EXCEPT** when a bid is under review. The bidders/public will only see the names of the bidders that submitted a bid, not their cost. This will protect the bidders cost in case there is a re-bid.

**If you have any questions, please feel free to give me a call or send an email.**

  
Signature

cc: Shelbi Frayer



# City of Flint

## Department of Finance

### Division of Purchases & Supplies

---

Sheldon A. Neeley

Today's Date:

Please complete the following form if you decide to rebid:

**Proposal #**

**DETAILED REASON FOR WANTING TO REBID:**

---

**Authorized Signature and Title:**

**Date Signed**

.....  
**PURCHASING USE ONLY**

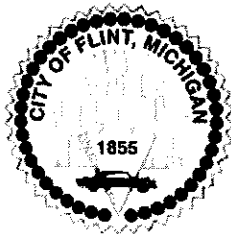

**SEALED PROPOSALS RECEIVED IN THE DIVISION OF PURCHASES & SUPPLIES**  
**For Janitorial Services – 3 Years with Option to Extend 2 Years**  
**PROPOSAL# 21000608**  
 Approximate Annual Quantities – Not Guaranteed  
 Furnish as requested for the period 7/1/21 – 6/30/24

**Bidder# 1: A & J Janitorial Services**  
**1401 Sunnyside Ave., Flint, MI 48503**

Name of Facility	Address of Facility	Specification Reference No. (as listed above)	Daily (M-F)		Monthly	
			# F/T (employees – man hrs.)	# P/T (employees) – man hrs.	# F/T – man hrs.	# P/T – man hrs.
City Hall Campus (Main Campus, North & South Building and Fire Adm.)	1101 S. Saginaw St., Flint, MI (floor plans attached)	A1	# F/T 2 Man hrs. 16	# P/T _____ Man hrs. _____	# F/T 2 Man hrs. 320	# P/T _____ Man hrs. _____
12 <sup>th</sup> St. Garage Facility – 6 hrs./day	702 W. 12 <sup>th</sup> St. Flint, MI	A2	# P/T 1 Man hrs. 6		# P/T 1 Man hrs. 120	
Water Service Center – 4 hrs./day	3301 E. Court St. Flint, MI		# P/T 1 Man hrs. 4		# P/T 1 Man hrs. 8	
Cleaning of the City Hall Dome	1101 S. Saginaw St. Flint, MI		# P/T 2 Man hrs. 16		# P/T 2 Man hrs. 80	
Cleaning of the Police Dept. equipment room (once a week)			# P/T 2 Man hrs. 16		# P/T 2 Man hrs. 240	

**Total Monthly Cost (Based upon 30-days, all daily, weekly and monthly) \$ 8,760**

**A SPECIAL NOTE FROM THE PURCHASING DIVISION**

*Bid results posted are before evaluation team review and award recommendation.*

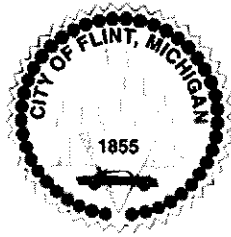

The following additional pricing breakdown is requested to insure clarity and fair comparison in all submitted proposals.

1. Per hour price for additional labor on a non-emergency basis.                   \$     15 /man hr.
2. Per hour price for additional labor on an emergency basis.                   \$     30 /man hr.
3. Per hour price for working on a holiday (Police Dept. only)                   \$    22.50 /man hr.
4. Please indicate if job will be staffed with full-time or part-time people, number of each employee designation and total man hours to be performed by those staffing levels (daily and weekly) by facility.
5. Please indicate total number of hours to be used to clean each facility.
6. Please indicate wages to be paid to janitorial staff.

**A SPECIAL NOTE FROM THE PURCHASING DIVISION**

*Bid results posted are before evaluation team review and award recommendation.*



**Bidder# 2: Professional Building Services, LLC**  
**119 S. Main St., Frankenmuth, MI 48734**

Name of Facility	Address of Facility	Specification Reference No. (as listed above)	Daily (M-F)		Monthly	
			# F/T (employees – man hrs.)	# P/T (employees) – man hrs.	# F/T – man hrs.	# P/T – man hrs.
City Hall Campus (Main Campus, North & South Building and Fire Adm.)	1101 S. Saginaw St., Flint, MI (floor plans attached)	A1	# F/T 8 Man hrs. 1	# P/T 18 Man hrs. 3	# F/T 1	Man hrs. 173 # P/T 3 Man hrs. 390
12 <sup>th</sup> St. Garage Facility – 6 hrs./day	702 W. 12 <sup>th</sup> St. Flint, MI	A2	# P/T 1.5 Man hrs. 1		# P/T 1	Man hrs. 30
Water Service Center – 4 hrs./day	3301 E. Court St. Flint, MI		# P/T 1.5 Man hrs. 1		# P/T 1	Man hrs. 30
Cleaning of the City Hall Dome	1101 S. Saginaw St. Flint, MI		# P/T 2 Man hrs. 1		# P/T 1	Man hrs. As Needed
Cleaning of the Police Dept. equipment room (once a week)			# P/T 1 Man hrs. 1		# P/T 1	Man hrs. 16

**Total Monthly Cost (Based upon 30-days, all daily, weekly and monthly) \$ 12,916 per month**

The following additional pricing breakdown is requested to insure clarity and fair comparison in all submitted proposals.

1. Per hour price for additional labor on a non-emergency basis. \$ 23 /man hr.
2. Per hour price for additional labor on an emergency basis. \$ 30 /man hr.
3. Per hour price for working on a holiday (Police Dept. only) \$ 40 /man hr.
4. Please indicate if job will be staffed with full-time or part-time people, number of each employee designation and total man hours to be performed by those staffing levels (daily and weekly) by facility. **See Attached Sheet**
5. Please indicate total number of hours to be used to clean each facility. **See Attached Sheet**
6. Please indicate wages to be paid to janitorial staff. **\$12 - \$15 per hour**

**A SPECIAL NOTE FROM THE PURCHASING DIVISION**

*Bid results posted are before evaluation team review and award recommendation.*



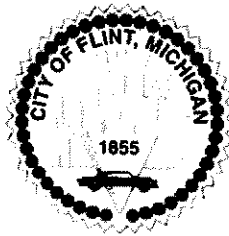

**Bidder# 3: LGC Global Energy FM, LLC**  
**7310 Woodward Ave., Suite 500, Detroit, MI 48202**

Name of Facility	Address of Facility	Specification Reference No. (as listed above)	Daily (M-F)		Monthly	
			# F/T (employees – man hrs.)	# P/T (employees) – man hrs.	# F/T – man hrs.	# P/T – man hrs.
City Hall Campus (Main Campus, North & South Building and Fire Adm.)	1101 S. Saginaw St., Flint, MI  (floor plans attached)	A1	# F/T 8 Man hrs.	# P/T 1 Man hrs.	# F/T 172 Man hrs.	# P/T 22 Man hrs.
12 <sup>th</sup> St. Garage Facility – 6 hrs./day	702 W. 12 <sup>th</sup> St. Flint, MI	A2	# P/T 4 Man hrs.		# P/T 87 Man hrs.	
Water Service Center – 4 hrs./day	3301 E. Court St. Flint, MI		# P/T 4 Man hrs.		# P/T 87 Man hrs.	
Cleaning of the City Hall Dome	1101 S. Saginaw St. Flint, MI		# P/T 1 Man hrs.		# P/T 22 Man hrs.	
Cleaning of the Police Dept. equipment room (once a week)			# P/T 6 Man hrs.		# P/T 130 Man hrs.	

**Total Monthly Cost (Based upon 30-days, all daily, weekly and monthly) \$ 13,249.26**

The following additional pricing breakdown is requested to insure clarity and fair comparison in all submitted proposals.

1. Per hour price for additional labor on a non-emergency basis. \$ 16.85 /man hr.
2. Per hour price for additional labor on an emergency basis. \$ 25.28 /man hr.
3. Per hour price for working on a holiday (Police Dept. only) \$ 25.28 /man hr.
4. Please indicate if job will be staffed with full-time or part-time people, number of each employee designation and total man hours to be performed by those staffing levels (daily and weekly) by facility. **Please refer to staffing plan.**
5. Please indicate total number of hours to be used to clean each facility. **Please refer to staffing plan.**
6. Please indicate wages to be paid to janitorial staff. **Janitor – Starting wage \$11.00/HR plus benefits (benefits are offered to both Full-time and part-time employees. Supervisor – Starting wage \$15.00/HR plus benefits.**

**A SPECIAL NOTE FROM THE PURCHASING DIVISION**

*Bid results posted are before evaluation team review and award recommendation.*

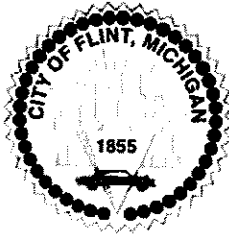

**Bidder# 4: Great Lakes Facility Management**  
**1428 W. Court Street, Flint, MI 48503**

Name of Facility	Address of Facility	Specification Reference No. (as listed above)	Daily (M-F)		Monthly	
			# F/T (employees – man hrs.)	# P/T (employees) – man hrs.	# F/T – man hrs.	# P/T – man hrs.
City Hall Campus (Main Campus, North & South Building and Fire Adm.)	1101 S. Saginaw St., Flint, MI (floor plans attached)	A1	# F/T 16 Man hrs.	# P/T 3 Man hrs.	# F/T 2 Full-time EE's Man hrs. 320	# P/T 1 P/T EE Man hrs. 60
12 <sup>th</sup> St. Garage Facility – 6 hrs./day	702 W. 12 <sup>th</sup> St. Flint, MI	A2	# P/T 5 Man hrs. 4 hours cleaning, 1 hour supervising		# P/T 2 P/T EE's Man hrs. 100	
Water Service Center – 4 hrs./day	3301 E. Court St. Flint, MI		# P/T 5 Man hrs. 4 hours cleaning, 1 hour supervising		# P/T 2 P/T EE's Man hrs. 100	
Cleaning of the City Hall Dome	1101 S. Saginaw St. Flint, MI		# P/T As Needed Man hrs.		# P/T 1 Man hrs. As Needed	
Cleaning of the Police Dept. equipment room (once a week)			# P/T 8 Man hrs.		# P/T 2 Man hrs. 160	

**Total Monthly Cost (Based upon 30-days, all daily, weekly and monthly) \$ 14,327.00**

The following additional pricing breakdown is requested to insure clarity and fair comparison in all submitted proposals.

1. Per hour price for additional labor on a non-emergency basis. \$ 16.00 /man hr.
2. Per hour price for additional labor on an emergency basis. \$ 20.00 /man hr.
3. Per hour price for working on a holiday (Police Dept. only) \$ 20.00 /man hr.
4. Please indicate if job will be staffed with full-time or part-time people, number of each employee designation and total man hours to be performed by those staffing levels (daily and weekly) by facility.
5. Please indicate total number of hours to be used to clean each facility.
6. Please indicate wages to be paid to janitorial staff.

**A SPECIAL NOTE FROM THE PURCHASING DIVISION**

*Bid results posted are before evaluation team review and award recommendation.*



Great Lakes FM would staff this project with 1-Full-time Working Supervisor and 4-Full-Time Custodians.

\*The Working Supervisor's starting pay would be \$14.00 per hour

\*The Custodians starting pay would be \$12.00 per hour

1. City Hall Campus – 19 Daily Manhours (2 F/T Custodians (16 hours) & 1 Working Supervisor (3 hours).
2. Police Dept. – 9 Daily Manhours (1 Custodian (6 hours) & 1 Working Supervisor (3 hours).
3. Water Service Ctr. – 4 Daily Manhours (1 dcustodian (4 hours) & 1 Working Supervisor (1 hour).
4. Garage – 4 Daily Manhours (1 Custodian (4 hours) & 1 Working Supervisor (1).

**A SPECIAL NOTE FROM THE PURCHASING DIVISION**

*Bid results posted are before evaluation team review and award recommendation.*



**Bidder# 5: RNA Facilities Management**  
**717 W. Ellsworth Rd., Ann Arbor, MI 48108**

Name of Facility	Address of Facility	Specification Reference No. (as listed above)	Daily (M-F)		Monthly	
			# F/T (employees – man hrs.)	# P/T (employees) – man hrs.	# F/T – man hrs.	# P/T – man hrs.
City Hall Campus (Main Campus, North & South Building and Fire Adm.)	1101 S. Saginaw St., Flint, MI (floor plans attached)	A1	# F/T 3 Man hrs. 24 # P/T 2 Man hrs. 10		# F/T 3 Man hrs. 528 # P/T 2 Man hrs. 90	
12 <sup>th</sup> St. Garage Facility – 6 hrs./day	702 W. 12 <sup>th</sup> St. Flint, MI	A2	# P/T 1 Man hrs. 4		# P/T 1 Man hrs. 88	
Water Service Center – 4 hrs./day	3301 E. Court St. Flint, MI		# P/T 1 Man hrs. 4		# P/T 1 Man hrs. 88	
Cleaning of the City Hall Dome	1101 S. Saginaw St. Flint, MI		# P/T 1 Man hrs. 4		# P/T 1 Man hrs. T.B.D.	
Cleaning of the Police Dept. equipment room (once a week)			# P/T 1 Man hrs. 1		# P/T 1 Man hrs. 4	

**Total Monthly Cost (Based upon 30-days, all daily, weekly and monthly) \$ 14,364.00**

The following additional pricing breakdown is requested to insure clarity and fair comparison in all submitted proposals.

1. Per hour price for additional labor on a non-emergency basis. \$ 18.00 /man hr.
2. Per hour price for additional labor on an emergency basis. \$ 25.00 /man hr.
3. Per hour price for working on a holiday (Police Dept. only) \$ 27.00 /man hr.
4. Please indicate if job will be staffed with full-time or part-time people, number of each employee designation and total man hours to be performed by those staffing levels (daily and weekly) by facility. **Both (see analysis on previous page)**
5. Please indicate total number of hours to be used to clean each facility. **Total: 798 hours/month**
6. Please indicate wages to be paid to janitorial staff. **\$18.00/hr.**

**A SPECIAL NOTE FROM THE PURCHASING DIVISION**

*Bid results posted are before evaluation team review and award recommendation.*

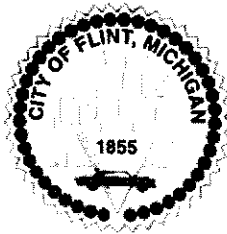

**Bidder# 6: Jus' Us Commercial Cleaning, LLC**  
**500 Fiske Dr., Detroit, MI 48214**

Name of Facility	Address of Facility	Specification Reference No. (as listed above)	Daily (M-F)		Monthly	
			# F/T (employees – man hrs.)	# P/T (employees) – man hrs.	# F/T – man hrs.	# P/T – man hrs.
City Hall Campus (Main Campus, North & South Building and Fire Adm.)	1101 S. Saginaw St., Flint, MI  (floor plans attached)	A1	# F/T 60 Man hrs.	# P/T 40 Man hrs.	# F/T 240 Man hrs.	# P/T 160 Man hrs.
12 <sup>th</sup> St. Garage Facility – 6 hrs./day	702 W. 12 <sup>th</sup> St. Flint, MI	A2		# P/T 60 Man hrs.		# P/T 2 Man hrs. 240
Water Service Center – 4 hrs./day	3301 E. Court St. Flint, MI			# P/T 40 Man hrs.		# P/T 2 Man hrs. 160
Cleaning of the City Hall Dome	1101 S. Saginaw St. Flint, MI			# P/T 40 Man hrs.		# P/T 2 Man hrs. 160
Cleaning of the Police Dept. equipment room (once a week)				# P/T 60 Man hrs.		# P/T 2 Man hrs. 240

**Total Monthly Cost (Based upon 30-days, all daily, weekly and monthly) \$ 14,458.00**

The following additional pricing breakdown is requested to insure clarity and fair comparison in all submitted proposals.

Per hour price for additional labor on a non-emergency basis.	\$	17.00 /man hr.
Per hour price for additional labor on an emergency basis.	\$	18.50 /man hr.
Per hour price for working on a holiday (Police Dept. only)	\$	25.50 /man hr.

**A SPECIAL NOTE FROM THE PURCHASING DIVISION**

*Bid results posted are before evaluation team review and award recommendation.*

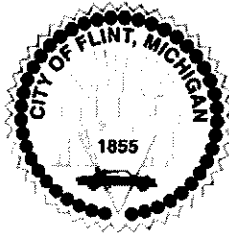

**Bidder# 7: CITI Building Services, Inc.**  
**1307-E Allen Dr., Troy, MI 48083**

Name of Facility	Address of Facility	Specification Reference No. (as listed above)	Daily (M-F)		Monthly	
			# F/T (employees – man hrs.)	# P/T (employees) – man hrs.	# F/T – man hrs.	# P/T – man hrs.
City Hall Campus (Main Campus, North & South Building and Fire Adm.)	1101 S. Saginaw St., Flint, MI (floor plans attached)	A1	# F/T 3 Man hrs. 24 # P/T 2 Man hrs. 8		# F/T 3 Man hrs. 520 # P/T 2 Man hrs. 174	
12 <sup>th</sup> St. Garage Facility – 6 hrs./day	702 W. 12 <sup>th</sup> St. Flint, MI	A2	# P/T 1 Man hrs. 4		# P/T 1 Man hrs. 87	
Water Service Center – 4 hrs./day	3301 E. Court St. Flint, MI		# P/T 1 Man hrs. 4		# P/T 1 Man hrs. 87	
Cleaning of the City Hall Dome	1101 S. Saginaw St. Flint, MI		# P/T 1 Man hrs. 1.5		# P/T 1 Man hrs. 32	
Cleaning of the Police Dept. equipment room (once a week)			# P/T 1 Man hrs. .5		# P/T 1 Man hrs. 2	

**Total Monthly Cost (Based upon 30-days, all daily, weekly and monthly) \$ 14,560.00**

The following additional pricing breakdown is requested to insure clarity and fair comparison in all submitted proposals.

1. Per hour price for additional labor on a non-emergency basis. \$ 16/24 OT /man hr.
2. Per hour price for additional labor on an emergency basis. \$ 32 /man hr.
3. Per hour price for working on a holiday (Police Dept. only) \$ 32 /man hr.
4. Please indicate if job will be staffed with full-time or part-time people, number of each employee designation and total man hours to be performed by those staffing levels (daily and weekly) by facility. **See page 37**
5. Please indicate total number of hours to be used to clean each facility. **See page 37 Pricing Page**
6. Please indicate wages to be paid to janitorial staff. **Starting wage is \$12 per hour**

**A SPECIAL NOTE FROM THE PURCHASING DIVISION**

*Bid results posted are before evaluation team review and award recommendation.*



**Bidder# 8: Michigan Building Cleaning and Maintenance**

Name of Facility	Address of Facility	Specification Reference No. (as listed above)	Daily (M-F)		Monthly	
			# F/T (employees – man hrs.)	# P/T (employees) – man hrs.	# F/T – man hrs.	# P/T – man hrs.
City Hall Campus (Main Campus, North & South Building and Fire Adm.)	1101 S. Saginaw St., Flint, MI  (floor plans attached)	A1	# F/T 12 Man hrs.	# P/T 10 Man hrs.	# F/T 240 Man hrs.	# P/T 200 Man hrs.
12 <sup>th</sup> St. Garage Facility – 6 hrs./day	702 W. 12 <sup>th</sup> St. Flint, MI	A2	# P/T 6 Man hrs.		# P/T 120 Man hrs.	
Water Service Center – 4 hrs./day	3301 E. Court St. Flint, MI		# P/T 4 Man hrs.		# P/T 80 Man hrs.	
Cleaning of the City Hall Dome	1101 S. Saginaw St. Flint, MI		# P/T 2 Man hrs.		# P/T 40 Man hrs.	
Cleaning of the Police Dept. equipment room (once a week)			# P/T 1 Man hrs.		# P/T 4 Man hrs.	

**Total Monthly Cost (Based upon 30-days, all daily, weekly and monthly) \$ 16,675.00**

The following additional pricing breakdown is requested to insure clarity and fair comparison in all submitted proposals.

1. Per hour price for additional labor on a non-emergency basis. \$ 25 /man hr.
2. Per hour price for additional labor on an emergency basis. \$ 45 /man hr.
3. Per hour price for working on a holiday (Police Dept. only) \$ 25 /man hr.
4. Please indicate if job will be staffed with full-time or part-time people, number of each employee designation and total man hours to be performed by those staffing levels (daily and weekly) by facility.
5. Please indicate total number of hours to be used to clean each facility.
6. Please indicate wages to be paid to janitorial staff.

**A SPECIAL NOTE FROM THE PURCHASING DIVISION**

*Bid results posted are before evaluation team review and award recommendation.*



**Bidder# 9: Michigan Merchant's  
P.O. Box 91, Mt. Morris, MI 48458**

Name of Facility	Address of Facility	Specification Reference No. (as listed above)	Daily (M-F)		Monthly	
			# F/T (employees – man hrs.)	# P/T (employees) – man hrs.	# F/T – man hrs.	# P/T – man hrs.
City Hall Campus (Main Campus, North & South Building and Fire Adm.)	1101 S. Saginaw St., Flint, MI  (floor plans attached)	A1	# F/T Man hrs.	# P/T 185 Man hrs. 7	# F/T Man hrs.	# P/T 740 Man hrs.
12 <sup>th</sup> St. Garage Facility – 6 hrs./day	702 W. 12 <sup>th</sup> St. Flint, MI	A2	# P/T 4 Man hrs. 20		# P/T 80 Man hrs.	
Water Service Center – 4 hrs./day	3301 E. Court St. Flint, MI		# P/T 20 Man hrs.		# P/T 80 Man hrs.	
Cleaning of the City Hall Dome	1101 S. Saginaw St. Flint, MI		# P/T Man hrs.		# P/T Man hrs.	
Cleaning of the Police Dept. equipment room (once a week)			# P/T 1 Man hrs.		# P/T 4 Man hrs.	

**Total Monthly Cost (Based upon 30-days, all daily, weekly and monthly) \$ 16,818.00**

The following additional pricing breakdown is requested to insure clarity and fair comparison in all submitted proposals.

- Per hour price for additional labor on a non-emergency basis.                                 \$        **17.50**        /man hr.
- Per hour price for additional labor on an emergency basis.   \$        **22.40**        /man hr.
- Per hour price for working on a holiday (Police Dept. only)   \$        **22.40**        /man hr.
- Please indicate if job will be staffed with full-time or part-time people, number of each employee designation and total man hours to be performed by those staffing levels (daily and weekly) by facility.
- Please indicate total number of hours to be used to clean each facility.
- Please indicate wages to be paid to janitorial staff.

**A SPECIAL NOTE FROM THE PURCHASING DIVISION**

*Bid results posted are before evaluation team review and award recommendation.*





**Bidder# 10: Master Maintenance Corporation  
2701 Interstate 94 Service Drive, Ypsilanti, MI 48198**

Name of Facility	Address of Facility	Specification Reference No. (as listed above)	Daily (M-F)		Monthly
			# F/T (employees – man hrs.)	# P/T (employees) – man hrs.	# F/T – man hrs.
City Hall Campus (Main Campus, North & South Building and Fire Adm.)	1101 S. Saginaw St., Flint, MI  (floor plans attached)	A1	# F/T *40 Man hrs.	# P/T Man hrs.	# F/T Man hrs. 860 # P/T Man hrs.
12 <sup>th</sup> St. Garage Facility – 6 hrs./day	702 W. 12 <sup>th</sup> St. Flint, MI	A2	# P/T *4 Man hrs.	*Daily Hours	# P/T Man hrs. 86
Water Service Center – 4 hrs./day	3301 E. Court St. Flint, MI		# P/T *4 Man hrs.	*Daily Hours	# P/T Man hrs. 86
Cleaning of the City Hall Dome	1101 S. Saginaw St. Flint, MI		# P/T 2 Man hrs.		# P/T Man hrs. 43
Cleaning of the Police Dept. equipment room (once a week)			# P/T 3 Man hrs.		# P/T Man hrs. 13

**Total Monthly Cost (Based upon 30-days, all daily, weekly and monthly) \$ 21,151.00**

The following additional pricing breakdown is requested to insure clarity and fair comparison in all submitted proposals.

- 1. Per hour price for additional labor on a non-emergency basis. \$ 25.00 /man hr.
- 2. Per hour price for additional labor on an emergency basis. \$ 40.00 /man hr.
- 3. Per hour price for working on a holiday (Police Dept. only) \$ 50.00 /man hr.

4. Please indicate if job will be staffed with full-time or part-time people, number of each employee designation and total man hours to be performed by those staffing levels (daily and weekly) by facility. (SEE COST ANALYSIS CHART)

5. Please indicate total number of hours to be used to clean each facility. (SEE COST ANALYSIS CHART)

6. Please indicate wages to be paid to janitorial staff. **\$13/HOUR FOR LEAD, \$12/HOUR CLEANER**

**A SPECIAL NOTE FROM THE PURCHASING DIVISION**

*Bid results posted are before evaluation team review and award recommendation.*



**Bidder# 10: Master Maintenance Corporation**  
**2701 Interstate 94 Service Drive, Ypsilanti, MI 48198**

**ALTERNATIVE BID PRICING**

Name of Facility	Address of Facility	Specification Reference No. (as listed above)	Daily (M-F)	Monthly
			#F/T (employees – man hrs.) # P/T (employees) – man hrs.	# F/T – man hrs. #P/T – man hrs.
City Hall Campus (Main Campus, North & South Building and Fire Adm.)	1101 S. Saginaw St., Flint, MI (floor plans attached)	A1	# F/T *32 Man hrs. # P/T Man hrs. *Daily Hours	# F/T Man hrs. 688 # P/T Man hrs.
12 <sup>th</sup> St. Garage Facility – 6 hrs./day	702 W. 12 <sup>th</sup> St. Flint, MI	A2	# P/T *4 Man hrs. *Daily Hours	# P/T Man hrs. 86
Water Service Center – 4 hrs./day	3301 E. Court St. Flint, MI		# P/T *4 Man hrs. *Daily Hours	# P/T Man hrs. 86
Cleaning of the City Hall Dome	1101 S. Saginaw St. Flint, MI		# P/T 2 Man hrs.	# P/T Man hrs. 43
Cleaning of the Police Dept. equipment room (once a week)			# P/T 3 Man hrs.	# P/T Man hrs. 13

**Total Monthly Cost (Based upon 30-days, all daily, weekly and monthly) \$ 17,956.00**

**A SPECIAL NOTE FROM THE PURCHASING DIVISION**

*Bid results posted are before evaluation team review and award recommendation.*

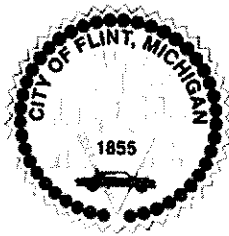

**Bidder# 11: CSM NewCo, LLC  
3536 Highland Drive, Hudsonville, MI 49548**

Name of Facility	Address of Facility	Specification Reference No. (as listed above)	Daily (M-F)		Monthly	
			# F/T (employees – man hrs.)	# P/T (employees) – man hrs.	# F/T – man hrs.	# P/T – man hrs.
City Hall Campus (Main Campus, North & South Building and Fire Adm.)	1101 S. Saginaw St., Flint, MI  (floor plans attached)	A1	# F/T 5     Man hrs. 40	# P/T     Man hrs.	# F/T 5 Man hrs. 800	# P/T Man hrs.
12 <sup>th</sup> St. Garage Facility – 6 hrs./day	702 W. 12 <sup>th</sup> St. Flint, MI	A2	# P/T 1     Man hrs. 4		# P/T 1 Man hrs. 86	
Water Service Center – 4 hrs./day	3301 E. Court St. Flint, MI		# P/T 1     Man hrs. 4		# P/T 1 Man hrs. 86	
Cleaning of the City Hall Dome	1101 S. Saginaw St. Flint, MI		# P/T 1     Man hrs. 1		# P/T 1 Man hrs. 30	
Cleaning of the Police Dept. equipment room (once a week)			# P/T 1     Man hrs. 2		# P/T 1 Man hrs. 8	

**Total Monthly Cost (Based upon 30-days, all daily, weekly and monthly) \$ 24,314.81**

**No specialty services included in proposal.**

The following additional pricing breakdown is requested to insure clarity and fair comparison in all submitted proposals.

- Per hour price for additional labor on a non-emergency basis. \$ 20.00 /man hr.
- Per hour price for additional labor on an emergency basis. \$ 30.00 /man hr.
- Per hour price for working on a holiday (Police Dept. only) \$ 35.00 /man hr.
- Please indicate if job will be staffed with full-time or part-time people, number of each employee designation and total man hours to be performed by those staffing levels (daily and weekly) by facility. **See attached staffing chart.**
- Please indicate total number of hours to be used to clean each facility. **See attached staffing chart.**
- Please indicate wages to be paid to janitorial staff. **See attached staffing chart.**

**A SPECIAL NOTE FROM THE PURCHASING DIVISION**

*Bid results posted are before evaluation team review and award recommendation.*



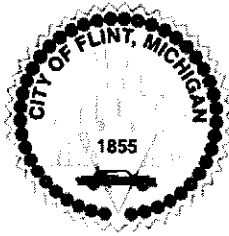

**Bidder# 13: Employment Group, Inc. DBA EG Workforce Solutions**  
**4651 W. Dickman Rd., Battle Creek, MI 49037**

EG's pricing proposal is included in the cost analysis chart below. Our proposed pricing includes a 3% yearly increase on cost (detailed in Total Proposed Pricing Chart below).

Name of Facility	Address of Facility	Specification Reference No. (as listed above)	Daily (M-F)		Monthly	
			# F/T (employees – man hrs.)	# P/T (employees) – man hrs.	# F/T – man hrs.	# P/T – man hrs.
City Hall Campus (Main Campus, North & South Building and Fire Adm.)	1101 S. Saginaw St., Flint, MI (floor plans attached)	A1	# F/T 3 Man hrs. 24	# P/T 0 Man hrs. 0	# F/T 3 Man hrs. 520	# P/T 0 Man hrs. 0
12 <sup>th</sup> St. Garage Facility – 6 hrs./day	702 W. 12 <sup>th</sup> St. Flint, MI	A2	# P/T 1 Man hrs. 4		# P/T 1 Man hrs. 86.7	
Water Service Center – 4 hrs./day	3301 E. Court St. Flint, MI		# P/T 1 Man hrs. 4		# P/T 1 Man hrs. 86.7	
Cleaning of the City Hall Dome	1101 S. Saginaw St. Flint, MI		# P/T 0 Man hrs. 0	City Hall staff to cover	# P/T 1 Man hrs. 6.67	
Cleaning of the Police Dept. equipment room (once a week)			# P/T 0 Man hrs. 0	City Hall staff to cover	# P/T 1 Man hrs. 6.67	

The following additional pricing breakdown is requested to insure clarity and fair comparison in all submitted proposals.

1. Per hour price for additional labor on a non-emergency basis. \$ **24.57** /man hr.
2. Per hour price for additional labor on an emergency basis. \$ **24.57** /man hr.
3. Per hour price for working on a holiday (Police Dept. only) \$ **45.00** /man hr.
4. Please indicate if job will be staffed with full-time or part-time people, number of each employee designation and total man hours to be performed by those staffing levels (daily and weekly) by facility. **Please refer to chart below #6.**
5. Please indicate total number of hours to be used to clean each facility. **Please refer to chart below #6.**
6. Please indicate wages to be paid to janitorial staff. **Custodian hourly pay rate will be \$12.50/hour and the Supervisor hourly pay rate is \$18.00/hour.**

**A SPECIAL NOTE FROM THE PURCHASING DIVISION**

*Bid results posted are before evaluation team review and award recommendation.*



**Bidder# 13: Employment Group, Inc. DBA EG Workforce Solutions  
4651 W. Dickman Rd., Battle Creek, MI 49037**

<b>Facility Name</b>	<b>Total Yearly Hours Worked</b>	<b>Cost for Services (Year 1)</b>	<b>Cost for Services (Year 2)</b>	<b>Cost for Services (Year 3)</b>
<b>City Hall</b>	6240	\$137,590.35	\$141,249.52	\$145,018.46
<b>12<sup>th</sup> St. Garage</b>	1040	\$22,311.95	\$22,905.33	\$23,516.51
<b>Water Service Center</b>	1040	\$22,311.95	\$22,905.33	\$23,516.51
<b>City Hall Dome</b>	80	\$1,859.33	\$1,908.78	\$1,959.71
<b>Police Department</b>	80	\$1,859.33	\$1,908.78	\$1,959.71
<b>Total</b>	<b>8480</b>	<b>\$185,932.91</b>	<b>\$190,877.73</b>	<b>\$195,970.90</b>

**A SPECIAL NOTE FROM THE PURCHASING DIVISION**

*Bid results posted are before evaluation team review and award recommendation.*

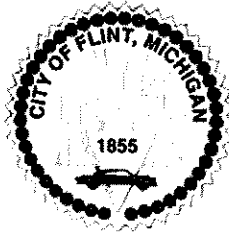

**Bidder# 14: CleanNet of Greater Michigan  
30665 Northwestern Hwy., Farmington Hills, MI 48334**

Name of Facility	Address of Facility	Specification Reference No. (as listed above)	Daily (M-F)		Monthly
			# F/T (employees – man hrs.)	# P/T (employees) – man hrs.	# F/T – man hrs.
City Hall Campus (Main Campus, North & South Building and Fire Adm.)	1101 S. Saginaw St., Flint, MI  (floor plans attached)	A1	# F/T 3     Man hrs. 24	# F/T 3	# F/T 3
			# P/T 1     Man hrs. 4	# P/T 1	Man hrs. 519.6
12 <sup>th</sup> St. Garage Facility – 6 hrs./day	702 W. 12 <sup>th</sup> St. Flint, MI	A2	# P/T 1     Man hrs. 4	# P/T 1	# P/T 1
					Man hrs. 86.6
Water Service Center – 4 hrs./day	3301 E. Court St. Flint, MI		# P/T 1     Man hrs. 4	# P/T 1	# P/T 1
					Man hrs. 86.6
Cleaning of the City Hall Dome	1101 S. Saginaw St. Flint, MI		# P/T 1     Man hrs. 1.5	# P/T 1	# P/T 1
					Man hrs.
Cleaning of the Police Dept. equipment room (once a week)			# P/T 1     Man hrs. .5	# P/T 1	# P/T 1
					Man hrs. 2.165

**Total Monthly Cost (Based upon 30-days, all daily, weekly and monthly)                    \$ 178,196.82**

The following additional pricing breakdown is requested to insure clarity and fair comparison in all submitted proposals.

1. Per hour price for additional labor on a non-emergency basis.                    \$        19        /man hr.
2. Per hour price for additional labor on an emergency basis.                    \$        25        /man hr.
3. Per hour price for working on a holiday (Police Dept. only)                    \$        25        /man hr.
4. Please indicate if job will be staffed with full-time or part-time people, number of each employee designation and total man hours to be performed by those staffing levels (daily and weekly) by facility.
5. Please indicate total number of hours to be used to clean each facility. **781.565**
6. Please indicate wages to be paid to janitorial staff. **\$10 – \$12/per hour**

**A SPECIAL NOTE FROM THE PURCHASING DIVISION**

*Bid results posted are before evaluation team review and award recommendation.*

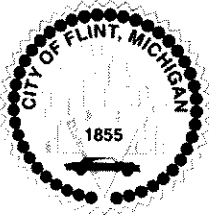

RESOLUTION NO.: 210257

PRESENTED: JUN - 6 2021

ADOPTED: \_\_\_\_\_

BY THE CITY ADMINISTRATOR:

**RESOLUTION TO MCNAUGHTON-MCKAY ELECTRIC FOR ADDITIONAL ELECTRICAL SERVICES**

WHEREAS, Water Service Center (WSC) requires electrical poles (3) to complete Phase 3 of the WSC electrical upgrades. WSC recommends that the existing contract PO 20-2793 with McNaughton-McKay Electric be extended to include these additional electrical poles.

Account Number	Account Name	Amount
590-540.208-752.000	Supplies	\$9,844.28
591-540.202-752.000	Supplies	\$9,844.29
	<b>FY2021 GRAND TOTAL</b>	<b>\$19,688.57</b>

IT IS RESOLVED, that the appropriate City Officials are authorized to do all things necessary to enter into change order #1 to the contract with McNaughton-McKay Electric to provide electrical poles for FY2021 for the amount of \$19,688.57 and a contract total amount of \$81,888.57 under the same terms and conditions.

APPROVED AS TO FORM:

Angela Wheeler  
Angela Wheeler (May 24, 2021 09:17 EDT)  
Angela Wheeler, Chief Legal Officer

APPROVED AS TO FINANCE:

Shelbi Frayer  
Shelbi Frayer (May 24, 2021 11:23 EDT)  
Shelbi Frayer, Chief Financial Officer

FOR THE CITY OF FLINT:

Clyde D. Edwards  
Clyde D. Edwards (May 24, 2021 14:25 EDT)  
Clyde Edwards, City Administrator

APPROVED BY CITY COUNCIL:

\_\_\_\_\_  
Kate Fields, City Council President

APPROVED AS TO PURCHASING:

Jennifer Ryan  
Jennifer Ryan (May 21, 2021 16:26 EDT)  
Jenn Ryan, Deputy Finance Director





**CITY OF FLINT**

**RESOLUTION STAFF REVIEW FORM**

**TODAY'S DATE:** 5/19/21

**BID/PROPOSAL#**

**AGENDA ITEM TITLE:** Purchase of 3 electrical poles

**PREPARED BY:** Cheri Priest, Utilities - Water Service Center

**VENDOR NAME:** McNaughton-McKay Electric

**BACKGROUND/SUMMARY OF PROPOSED ACTION:**

The WSC requests that funds be merged into our existing PO#20-2793 for the purchase of 3 electrical poles which are needed to complete phase 3 of the WSC electrical upgrades. See attached paperwork.

**FINANCIAL IMPLICATIONS:** None

**BUDGETED EXPENDITURE?** YES  NO  IF NO, PLEASE EXPLAIN:

Dept.	Name of Account	Account Number	Grant Code	Amount
2496	Supplies	590-540.208-752.000	N/A	9,844.28
2493	Supplies	591-540.202-752.000	N/A	9,844.29
		<b>FY20/21 GRAND TOTAL</b>		<b>19,688.57</b>

**PRE-ENCUMBERED?** YES  NO  **REQUISITION NO:** 21-00004543

**ACCOUNTING APPROVAL:** \_\_\_\_\_ **Date:** \_\_\_\_\_



## CITY OF FLINT

---

WILL YOUR DEPARTMENT NEED A CONTRACT? YES  NO

WHEN APPLICABLE, IF MORE THAN ONE (1) YEAR, PLEASE ESTIMATE TOTAL AMOUNT FOR EACH BUDGET YEAR: *(This will depend on the term of the bid proposal)*

BUDGET YEAR 1

BUDGET YEAR 2

BUDGET YEAR 3

OTHER IMPLICATIONS *(i.e., collective bargaining)*:

STAFF RECOMMENDATION: *(PLEASE SELECT)*:  APPROVED  NOT APPROVED

DEPARTMENT HEAD SIGNATURE: \_\_\_\_\_

*(Michael J. Brown, DPW Director)*

**McNaughton McKay Electric**  
**1011 E. 5th Avenue Flint, MI 48503**



**McNAUGHTON-McKAY**  
**ELECTRIC COMPANY**  
 YOUR ELECTRICAL CONNECTION



Tim Donlan  
 City of Flint WPC  
 Flint, MI

March 31, 2021

Subject: WSC Phase III Storage Lot

Qty	Part Number	Description	Price (ea.)	Extended
2	Pole with 3 fixtures		\$ 6,717.14	\$ 13,434.29
	RFL5-360L-265-5K7-W-UNV-K/DBT	Flood, 120-277V	\$ -	\$ -
	BHH-3120-PT20-DBT	bull horn	\$ -	\$ -
	THSP30-6.25-7-BRZ-2-BC	30' hinged pole	\$ -	\$ -
	ATB1-17-BRZ	transformer base	\$ -	\$ -
			\$ -	\$ -
1	Pole with 2 fixtures		\$ 6,254.29	\$ 6,254.29
	RFL5-360L-265-5K7-W-UNV-K/DBT	Flood, 120-277V	\$ -	\$ -
	BHH-2180-PT20-DBT	bull horn	\$ -	\$ -
	THSP30-6.25-7-BRZ-2-BC	30' hinged pole	\$ -	\$ -
	ATB1-17-BRZ	transformer base	\$ -	\$ -
			\$ -	\$ -
		<b>Total</b>	\$ -	\$ 19,688.57
			\$ -	\$ -
			\$ -	\$ -
			\$ -	\$ -
			\$ -	\$ -
			\$ -	\$ -

*\*Does not include tax*

This quotation expires in 30 days

All voltages, colors, mounting, tenons, photo cells, etc. to be field verified by installing contractor.

Shipping is not included.

Thank you for the opportunity.

Prepared by: Duc Nguyen  
 Account Manager  
 810.424.5065  
 1011 E. 5th Ave  
 Flint, MI 48503

<https://www.mc-mc.com/terms>

# RATIO Flood

MEDIUM AND LARGE

## ADDITIONAL INFORMATION

### SHIPPING INFORMATION

Catalog Number	G.W (kg)/CTN	Carton Dimensions		
		Length Inch (cm)	Width Inch (cm)	Height Inch (cm)
RFL4	15lbs (6.8kg)	20.75 (52.7)	15.125 (38.4)	6.9375 (17.6)
RFL5	19lbs (8.6kg)	25 (63.5)	15.125 (38.4)	6.9375 (17.6)

### ACCESSORIES

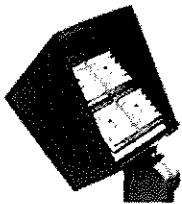

Visor

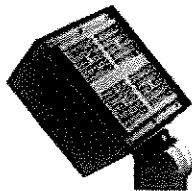

Louver

All product and company names, logos and product identifiers are trademarks™ or registered trademarks® of Hubbell Lighting, Inc. or their respective owners. Use of them does not necessarily imply any affiliation with or endorsement by such respective owners.

DATE: \_\_\_\_\_ LOCATION: \_\_\_\_\_  
 TYPE: \_\_\_\_\_ PROJECT: \_\_\_\_\_  
 CATALOG #: \_\_\_\_\_

# RATIO Flood

MEDIUM AND LARGE

## PROJECTED LUMEN MAINTENANCE

Ambient Temperature	Operating Hours					Calculated L70 (Hours)
	0	25,000	50,000	TM-21-11 60,000 <sup>1</sup>	100,000	
25°C / 77°F	1.00	0.96	0.94	0.91	0.83	> 191,000
40°C / 104°F	0.99	0.95	0.93	0.93	0.81	> 173,000

## LUMINAIRE AMBIENT TEMPERATURE FACTOR (LATF)

Ambient Temperature		Lumen Multiplier
0° C	32° F	1.03
10° C	50° F	1.01
20° C	68° F	1.00
25° C	77° F	1.00
30° C	86° F	0.99
40° C	104° F	0.98
50° C	122° F	0.97

Use these factors to determine relative lumen output for average ambient temperatures from 0–50°C (32–122°F)

## DIMENSIONS

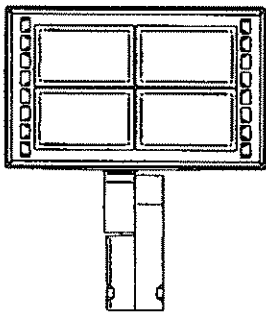

RFL4

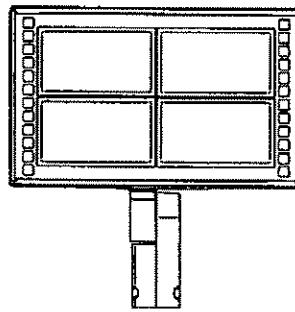

RFL5

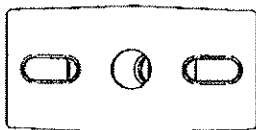

Trunnion Mount

DATE: \_\_\_\_\_ LOCATION: \_\_\_\_\_  
 TYPE: \_\_\_\_\_ PROJECT: \_\_\_\_\_  
 CATALOG #: \_\_\_\_\_

# RATIO Flood

MEDIUM AND LARGE

## CONTROLS

### NX Distributed Intelligence™ Lighting Controls:

Supports both indoor and outdoor applications in a variety of deployment options- wired, wireless, hybrid  
 Integrates with and enables a wide array of luminaires including those with SpectraSync Color Tuning Technology.



NX Integrated Controls Reference								
NX Option	Sensor	Networkable	Scheduling	Occupancy	Daylight Harvesting	0-10V Dimming	On/off Control	Bluetooth® App Programming
<b>NX Standalone</b>								
<u>NXSP14F</u>	NXSMP-LMO	No	Yes	Yes	Yes	Yes	Yes	Yes
<u>NXSP30F</u>	NXSMP-HMO	No	Yes	Yes	Yes	Yes	Yes	Yes
<b>NX Networked – Wired</b>								
<u>NXSPW14F</u>	NXSMP-LMO	Yes	Yes	Yes	Yes	Yes	Yes	Yes, Bluetooth App
<u>NXSPW30F</u>	NXSMP-HMO	Yes	Yes	Yes	Yes	Yes	Yes	Yes, Bluetooth App
<u>NXWE</u>	N/A	Yes	Yes	No	No	Yes	Yes	No. See footnote

## ELECTRICAL DATA

# LEADS	Nominal Wattage	Input Voltage	Oper. Current (Amps)	System Power (W)
RFL4	95	120	0.78	93.5
		208	0.45	
		240	0.39	
		277	0.34	
	120	120	1.00	120.2
		208	0.58	
		240	0.50	
		277	0.43	
RFL5	130	120	1.11	132.6
		208	0.58	
		240	0.50	
		277	0.43	
	190	120	1.59	191
		208	0.92	
		240	0.80	
		277	0.69	
	265	120	2.10	252
		208	1.21	
		240	1.05	
		277	0.91	

To enable scheduling and for use with NX wall control preset stations please refer to Hubbell Control Solutions NX SpectraSync technical sheet.

# RATIO Flood

MEDIUM AND LARGE

# RATIO

## FEATURES

- Medium and Large LED flood with a variety of NEMA distributions for lighting applications such as area safety/security, accent, flag pole columns, or signs
- Part of the Ratio Flood series, this luminaire was designed in cohesion with the site-area products to provide a sleek and timeless look
- Features a dense optical array, providing reduced pixelation and increased visual comfort without compromising performance
- Applications include safety/security, accent, flag pole, columns and signs

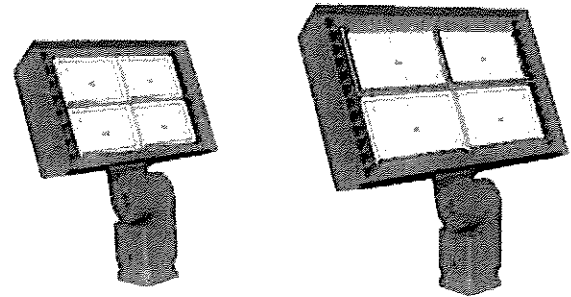

RFL4

RFL5

### RELATED PRODUCTS

- ⊘ [RATIO Family](#)
⊘ [RFL1](#)
⊘ [RFL2](#)
⊘ [RFL3](#)

## CONTROL TECHNOLOGY



DLC # P37G5D48 - TYPE A - RFL5

DLC # PV1G06M0 - TYPE F - RFL4

## SPECIFICATIONS

### CONSTRUCTION

- Corrosion resistant, rugged die-cast aluminum housing with powder coat paint finish
- High impact UV stabilized acrylic outer lens protects LEDs and allows for cleaning and debris removal
- Internal venting fins create optimal heat dissipation and allow all water to drain from the face of the luminaire
- Visor, louver and vandal Lens options
- Easy maintenance access to electrical components with removal of four screws from back of fixture housing
- Lens hardware is internal to the fixture allowing for uniform pressure on the gasket for an optimal water tight seal

### OPTICS

- 176 or 360 midpower LEDs
- Stock Versions 4000K and 5000K CCT
- Variety of NEMA distributions: N (3x3), M (4x4), and W (6x6) Stock version W de (6x6) only
- Entire optical aperture illuminates to create a larger luminous surface area resulting in a low glare appearance without sacrificing optical performance

### CONTROLS

- Photo control, occupancy sensor and wireless available for complete on/off dimming control

### CONTROLS (CONTINUED)

- 7-pin ANSI C136 41-2013 photocontrol receptacle option available for twist lock photocontrols or wireless control modules (control accessories sold separately)
- 0-10V dimming leads available for use with control devices (provided by others), must specify lead length
- 0-10V dimming driver standard, continuous dimming option to have leads pulled out for easy connection
- SiteSync™ wireless control system is available via 7-pin and can be ordered separately. See ordering information and details at [www.hubbell-lighting.com](http://www.hubbell-lighting.com)

### INSTALLATION

- Interchangeable knuckle and trunnion mounting options
- Knuckle arm fitter option available for 2-1/4" OD tenon 180 degrees of adjustability (with no options) 4 degree adjustable increments
- Trunnion option available for surface and crossarm mounting using (1) 3/4" or (2) 1/2" size through bolts

### ELECTRICAL

- 120-480V operation, 50/60Hz
- Driver IP66 and RoHS compliant driver
- Ambient operating temperature -40°C to 40°C (295W configuration rated for 25°C)

### ELECTRICAL (CONTINUED)

- 7-pin module can limit backwards rotation of the luminaire
- Drivers have 90% power factor and less than 20% THD
- LED drivers have output power over-voltage over-current protection and short circuit protection with auto recovery
- 10kA surge protector optional

### CERTIFICATIONS

- Fixture is IP66 rated
- Listed to UL1598 for use in wet locations
- DLC® (DesignLights Consortium) Qualified, with some Premium Qualified configurations. Please refer to the DLC website for specific product qualifications at [www.designlights.org](http://www.designlights.org)

### WARRANTY

- 5 year limited warranty
- See [HLI Standard Warranty](#) for additional information

KEY DATA	
Lumen Range	12,000-30,000
Wattage Range	124-266
Efficacy Range (LPW)	116-125
Reported Life (Hours)	L70>191,000
Weights lbs. (kg)	16.0-25.7 (7.2-11.66)

DATE LOCATION  
 TYPE PROJECT  
 CATALOG #

# RATIO Flood

MEDIUM AND LARGE

## STOCK ORDERING INFORMATION

Catalog Number	Mounting	Distribution	Wattage	Voltage	CCT	Lumens	LPW	Weight lbs. (KG)	Finish
RFL4-120-5K-K	Knuckle	Wide	124	120-277V	5000K	14746	122	16.0 (7.26)	Bronze
RFL4-120-4K-K	Knuckle	Wide	124	120-277V	4000K	15119	125	16.0 (7.26)	Bronze
RFL4-120-5K-T	Trunnon	Wide	124	120-277V	5000K	14746	122	16.0 (7.26)	Bronze
RFL4-120-4K-T	Trunnon	Wide	124	120-277V	4000K	15119	125	16.0 (7.26)	Bronze
RFL5-265-5K-K	Knuckle	Wide	266	120-277V	5000K	29362	116	25.7 (11.66)	Bronze
RFL5-265-4K-K	Knuckle	Wide	266	120-277V	4000K	30106	119	25.7 (11.66)	Bronze
RFL5-265-5K-T	Trunnon	Wide	266	120-277V	5000K	29362	116	25.7 (11.66)	Bronze
RFL5-265-4K-T	Trunnon	Wide	266	120-277V	4000K	30106	119	25.7 (11.66)	Bronze
RFL-TRN-XX <sup>1</sup>	Trunnon Accessory Kit								

<sup>1</sup> Specify finish color to match fixture

## ORDERING GUIDE

CATALOG #  Example: RFL4-176L-95-3K7-M-UNV-K-GYS

Model	Ratio Flood Size	# LEDs - Watts	CCT: CRI	Distribution	Voltage	Mounting
RFL4	Ratio Flood Size 4	176L-95 176 LEDs-12000lm	3K7 3000K, 70 CRI	N Narrow, 2x2	UNV Universal 120-277	K Knuckle
RFL5	Ratio Flood Size 5	176L-120 176 LEDs-15000lm	4K7 4000K, 70 CRI	M Medium Flood, 4x4	120 120V	T Trunnon
		360L-130 360 LEDs-18000lm	5K7 5000K, 70 CRI	W Wide Flood, 6x6	208 208V	
		360L-190 360 LEDs-25000lm			240 240V	
		360L-265 360 LEDs-30000lm			277 277V	
					347 347V	
					480 480V	

Color	Control Options	Options
GYS Light gray smooth	PC Button style photocontrol	SP Surge Protector
DB Dark bronze textured	CD Continuous dimmable	F Fusing
BL Black textured		
GT Graphite textured		
PS Platinum silver smooth		
WH White textured		
CC Custom color		

### Control Options

- NX Standalone**
- NXSP14F<sup>1</sup> NX, PIR, BT Occ. Sensor, Daylight Harvesting, up to 14' mounting height
  - NXSP30F<sup>1</sup> NX, PIR, BT Occ. Sensor, Daylight Harvesting, 14-30' mounting height

- NX Networked - Wireless**
- NXSPWMF<sup>1,2</sup> NX Wireless, PIR, BT, Occupancy Sensor, Daylight Harvesting, up to 12' mounting height
  - NXSPW30F<sup>1,2</sup> NX Wireless, PIR, BT, Occupancy Sensor, Daylight Harvesting, 14-30' mounting height
  - NXWE<sup>1</sup> NX Wireless Enabled

- Third-Party Control Options**
- SCP-F<sup>1,2</sup> Programmable occupancy sensor
  - 7PR<sup>1,3</sup> 7-Pin twist lock receptacle
  - 7PR-SC<sup>1,3</sup> 7-Pin receptacle with shoring cap
  - 7PR-MD-F<sup>1,3</sup> Low voltage sensor for 7PR
  - 7PR-TL<sup>1,3</sup> 7-Pin PCR with photo control

1 Option available with knuckle mounting  
 2 Available with knuckle option only  
 3 Limits backwards rotation based on module height



# RATIO Flood

MEDIUM AND LARGE

## ACCESSORIES AND REPLACEMENT PARTS (ORDERED SEPARATELY)

	Catalog Number	Description
<input type="checkbox"/>	RFL4-TV-XX'	Top Visor - RFL4
<input type="checkbox"/>	RFL4-FL-XX'	Louver - RFL4
<input type="checkbox"/>	RFL5-TV-XX'	Top Visor - RFL5
<input type="checkbox"/>	RFL5-FL-XX'	Louver - RFL5

1 Specify finish color to match fixture e.g. CB - Bronze

## HUBBELL CONTROL SOLUTIONS ACCESSORIES

	Catalog Number	Description	HCS System
<input type="checkbox"/>	NXOFM-1R1D-UNV	On-fixture Module (7-pin), On / Off / Dim, Daylight Sensor with HubbNET Radio and Bluetooth® Radio, 120-480VAC	NX Distributed Intelligence™
<input type="checkbox"/>	WIR-RME-L	On-fixture Module (7-pin or 5-pin), On / Off / Dim, Daylight Sensor with wiSCAPE Radio, 110-480VAC	wiSCAPE® Lighting Control

## CONTROL ACCESSORIES

	Catalog Number	Description
<input type="checkbox"/>	SW7PR	SiteSync™ on fixture module via 7PR
<input type="checkbox"/>	SWUSB	SiteSync™ Software on USB
<input type="checkbox"/>	SWTAB	SiteSync™ Windows Tablet
<input type="checkbox"/>	SWBRG	SiteSync™ Wireless Bridge Node
<input type="checkbox"/>	SWFC	SiteSync™ Field Commission Serv
<input type="checkbox"/>	SCPREMOTE	Order at least one per project location to program and control
<input type="checkbox"/>	WIR-RME-L	wiSCAPE™ external control node, use with 7PR
<input type="checkbox"/>	NXOFM-1R1D-UNV	NX external control node, use with 7PR

## PERFORMANCE DATA

Series	Nominal Watts	Dist. Type	NEMA	Field Angle H X V	5K (5000K nominal, 70 CRI)			4K (4000K nominal, 70 CRI)			3K (3000K nominal, 70 CRI)		
					Lumens	LPW <sup>1</sup>	Max Beam Candlepower	Lumens	LPW <sup>1</sup>	Max Beam Candlepower	Lumens	LPW <sup>1</sup>	Max Beam Candlepower
RFL4	95	N	2 x 2	20 x 20	12594	135	213259	12913	140	218652	12510	136	211825
		M	4 x 4	57 x 57	11894	128	28457	12196	131	29177	11816	127	82866
		W	6 x 6	105 x 105	12355	132	7037	12668	135	7215	12272	131	6990
	120	N	2 x 2	20 x 20	15031	127	254521	15411	130	260957	14931	126	252810
		M	4 x 4	57 x 57	14196	119	33912	14555	122	34770	14102	118	33684
		W	6 x 6	105 x 105	14746	122	8399	15119	125	8611	14647	121	8343
RFL5	130	N	2 x 2	20 x 20	19019	145	322063	19501	149	330208	18892	144	319898
		M	4 x 4	57 x 57	17963	136	44645	18419	140	45774	17843	135	44345
		W	6 x 6	105 x 105	18658	140	10628	19131	144	10897	18534	139	10557
	150	N	2 x 2	20 x 20	25278	134	428052	25918	139	438877	25110	133	425174
		M	4 x 4	57 x 57	23875	126	58831	24478	129	60319	23714	125	58436
		W	6 x 6	105 x 105	24799	129	14126	25427	133	14483	24634	128	14031
	265	N	2 x 2	20 x 20	29930	120	30685	30688	123	519638	29730	120	503414
		M	4 x 4	57 x 57	28268	113	68911	28983	119	70654	28078	112	68448
		W	6 x 6	105 x 105	29362	116	30106	30106	119	17148	29167	115	16612

<sup>1</sup> Lumen values are from photometric tests performed in accordance with IESNA LM-79-03. Data is considered to be representative of the configurations shown. Actual performance may differ as a result of end-user environment and application.



# RATIO Flood

MEDIUM AND LARGE

## CONTROLS

### NX Distributed Intelligence™ Lighting Controls:

Supports both indoor and outdoor applications in a variety of deployment options- wired, wireless, hybrid  
 Integrates with and enables a wide array of luminaires including those with SpectraSync Color Tuning Technology.



NX Integrated Controls Reference								
NX Option	Sensor	Networkable	Scheduling	Occupancy	Daylight Harvesting	0-10V Dimming	On/off Control	Bluetooth® App Programming
<b>NX Standalone</b>								
NXSP14F	NXSMP-LMO	No	Yes	Yes	Yes	Yes	Yes	Yes
NXSP30F	NXSMP-HMO	No	Yes	Yes	Yes	Yes	Yes	Yes
<b>NX Networked – Wired</b>								
NXSPW14F	NXSMP-LMO	Yes	Yes	Yes	Yes	Yes	Yes	Yes, Bluetooth App
NXSPW30F	NXSMP-HMO	Yes	Yes	Yes	Yes	Yes	Yes	Yes, Bluetooth App
NXWE	N/A	Yes	Yes	No	No	Yes	Yes	No. See footnote

## ELECTRICAL DATA

# LEADS	Nominal Wattage	Input Voltage	Oper. Current (Amps)	System Power (W)
RFL4	95	120	0.78	93.5
		208	0.45	
		240	0.39	
		277	0.34	
	120	120	1.00	120.2
		208	0.58	
		240	0.50	
		277	0.43	
RFL5	130	120	1.11	132.6
		208	0.58	
		240	0.50	
		277	0.43	
	190	120	1.59	191
		208	0.92	
		240	0.80	
		277	0.69	
	265	120	2.10	252
		208	1.21	
		240	1.05	
		277	0.91	

To enable scheduling and for use with NX wall control preset set or's please refer to Hubbell Control Solutions NX SpectraSync technical sheet

# RATIO Flood

MEDIUM AND LARGE

## PROJECTED LUMEN MAINTENANCE

Ambient Temperature	Operating Hours					Calculated L70 (Hours)
	0	25,000	50,000	TM-21-11 60,000*	100,000	
25°C / 77°F	1.00	0.96	0.94	0.91	0.83	> 191,000
40°C / 104°F	0.99	0.95	0.93	0.93	0.81	> 173,000

## LUMINAIRE AMBIENT TEMPERATURE FACTOR (LATF)

Ambient Temperature		Lumen Multiplier
0° C	32° F	1.03
10° C	50° F	1.01
20° C	68° F	1.00
25° C	77° F	1.00
30° C	86° F	0.99
40° C	104° F	0.98
50° C	122° F	0.97

Use these factors to determine relative lumen output for average ambient temperatures from 0-50°C (32-122°F).

## DIMENSIONS

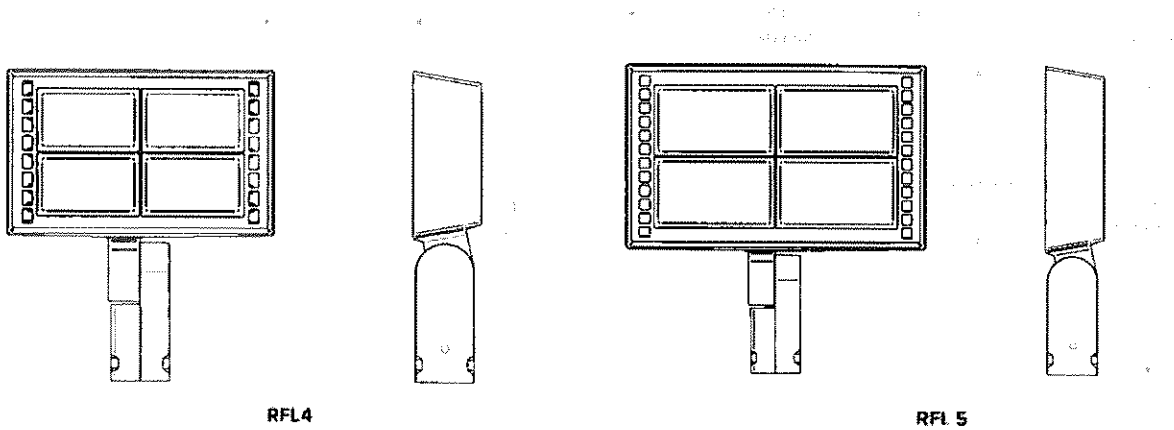

RFL4

RFL5

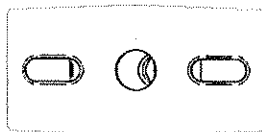

Trunnion Mount

DATE \_\_\_\_\_ LOCATION \_\_\_\_\_  
 TYPE \_\_\_\_\_ PROJECT \_\_\_\_\_  
 CATALOG # \_\_\_\_\_

# RATIO Flood

MEDIUM AND LARGE

## ADDITIONAL INFORMATION

### SHIPPING INFORMATION

Catalog Number	G.W (kg)/CTN	Carton Dimensions		
		Length Inch (cm)	Width Inch (cm)	Height Inch (cm)
RFL4	15lbs (6.8kg)	20.75 (52.7)	15.125 (38.4)	6.9375 (17.6)
RFL5	19lbs (8.6kg)	25 (63.5)	15.125 (38.4)	6.9375 (17.6)

### ACCESSORIES

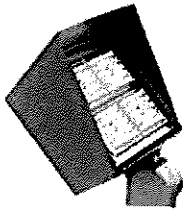

Visor

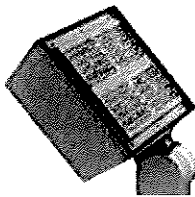

Louver

All product and company names, logos and product identifiers are trademarks \* or reg. stated trademarks of Hubbell Lighting, Inc. or their respective owners. Use of them does not necessarily imply any affiliation with or endorsement by such respective owners.

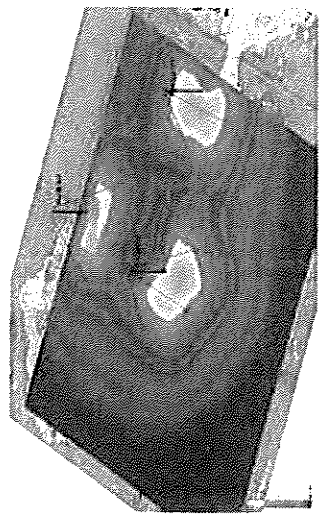
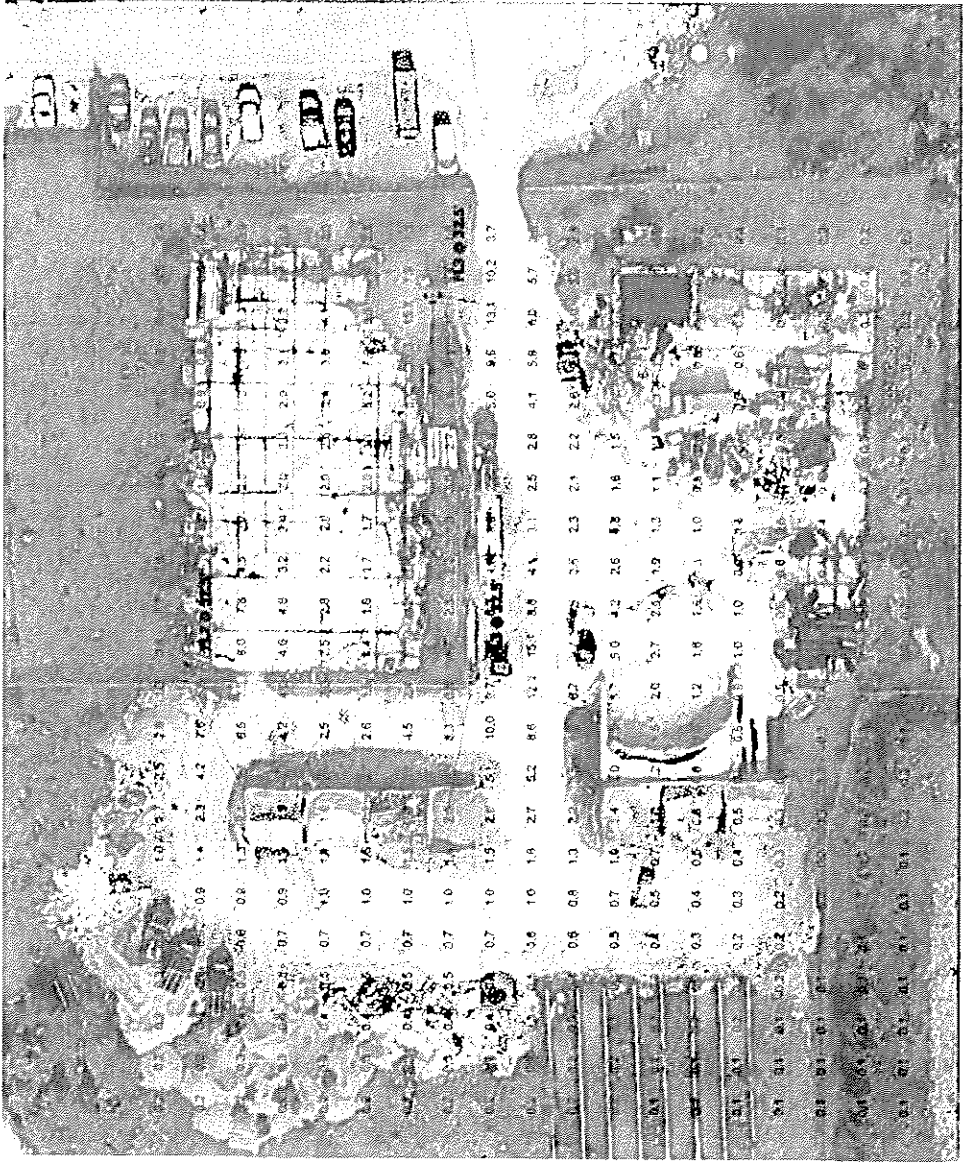

Statistics					
Description	Symbol	Avg	Max	Min	Max/Min
Calc Zone 45	4	1.58	1.52	0.10	15.20

Notes			
1	All Police Stations are to be 30' Square Street Light w/ Transformer Base		
2	Luminaires Mounted @ 32.5' AFS		

All Police Stations are to be 30' Square Street Light w/ Transformer Base  
Luminaires Mounted @ 32.5' AFS



THSP

## Square Tapered Steel Hinged Poles

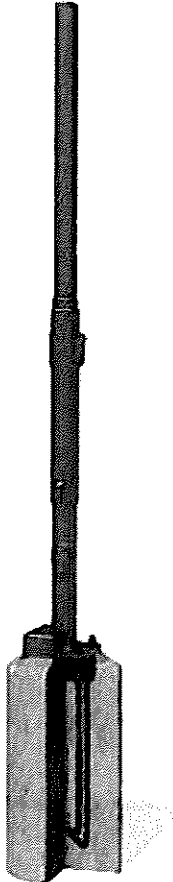

### Pole Shaft

The pole shaft is two section design, each section being fabricated from standard 7 gauge (0.1793") steel. The pole shaft material is a weldable grade hot rolled commercial quality carbon steel with a guaranteed minimum yield strength of 55,000 psi after fabrication. Each section is one-piece construction with a full length longitudinal weld and is square in cross-section having a uniform taper of 0.10 in./in. of diameter change per foot of length.

### Base Plate

The anchor base is fabricated from a structural quality hot rolled carbon steel plate that meets or exceeds a minimum yield strength of 36,000 psi. The anchor base telescopes the pole shaft and is circumferentially welded top and bottom. All welds are performed in accordance with the American Welding Society specification AWS D1.1, latest edition.

**Bolt Circle:** 12.50 (in.) **Dimension :** 11.88 (in.) **Thickness:** 1.00 (in.) **Conduit Opening:** 5 (in.)  
Consult KW representative for non-standard dimensions.

### Anchor Bolts

Anchor bolts are fabricated from commercial quality hot rolled carbon steel bar that meets or exceeds a minimum yield strength of 55,000 psi. Four properly sized anchor bolts, each with two regular hex nuts and washers, are furnished and shipped with all poles unless otherwise specified. Anchor bolts shall have the threaded end galvanized a minimum of 8 inches in accordance with ASTM A153. Fully galvanized anchor bolts are available upon request.

### Handhole

An oval reinforced gasketed handhole, having a nominal 4" x 6.5" inside opening, located at 1' - 6" above the base, is standard on all poles. A grounding provision is located inside the handhole ring.

### Finish

**Standard** - The exterior surface is cleaned with an alkaline rinse to remove surface contaminants and shot blasted to specifications as published by the Steel Structures Painting Council Standards SSPC-SP10 (near white). The exterior surface is chemically pretreated with an iron phosphate conversion coating then rinsed with ambient fresh water containing special surfactants and sealers forming a dry tight micro-crystalline coating. A polyester thermosetting powder coating applied to the surface of the substrate to a minimum of 3 mils is standard on all color finishes. The internal surface including the powder coated area at the base end is coated with **AKASOL**, a thermoplastic hydrocarbon resin system specially formulated for application over untreated steel surfaces, to a thickness of 3 mils. The internal coating shall contain special corrosion inhibitors and is capable of passing 1000 hours of salt spray exposure (ASTM B117).

Series: **THSP** - Square Tapered Steel Hinged Poles  
Nominal Height: **30'** Base Diameter: **6.25"** Gauge: **7**  
Finish: **BRZ** - Standard - Bronze  
Mounting Designation: **2** - 2 3/8" x 4" TENON  
Options: **BC** - Base Cover

Height (ft.)	Pole Shaft (in.) x (in.) x (ft.)	Gauge	Handhole Size (in.)	Anchor Bolt (in.) x (in.) x (in.)	Bolt Circle (in.)	80 MPH (ft.)	90 MPH (ft.)	100 MPH (ft.)	Ship WT. (lbs.)	Hinge Point 'H' (ft.)	'H' <sup>2</sup> (ft.)
30	6.25 x 3.2 x 30	7	4 x 6.5	1.00 x 3/8 x 4	12.5	32.7	24	18	528	15	3.42
<b>THSP30-6.25-7-BRZ-2-BC</b>											

[Print This Page](#)    [Main Menu](#)



## Terms and Conditions of Sale

### TERMS

Net 30 days from the date of Company's invoice unless otherwise specified. A 1 1/2% per month late charge will be added to accounts past due.

### PRICES

Published prices are subject to change without notice. Possession of price sheets in no way obligates Company to sell to the Purchaser possessing such price sheet. All orders are subject to final approval and acceptance by the Company. Once accepted and approved, orders will be billed at prices currently in effect at the time of invoicing, or at prices quoted by the

## Breakaway Bases

**ATB1-17**

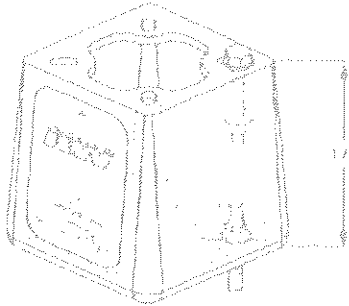

**ATB2-17**

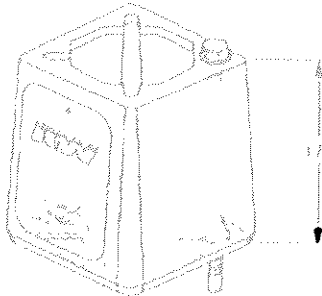

**ATB3-17**

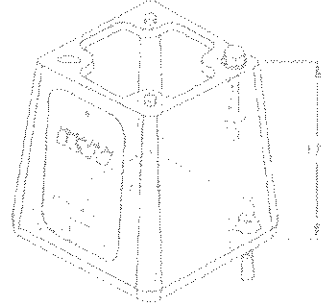

### Top View

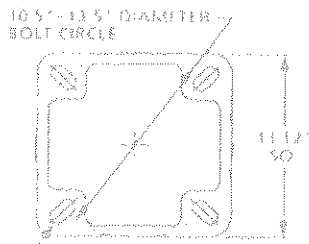

(4) SLOTTED HOLES FOR 1.0\"/>

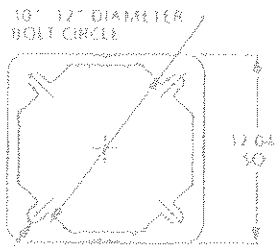

(4) SLOTTED HOLES FOR 1.0\"/>

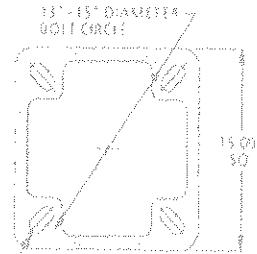

(4) SLOTTED HOLES FOR 1.25\"/>

### Bottom View

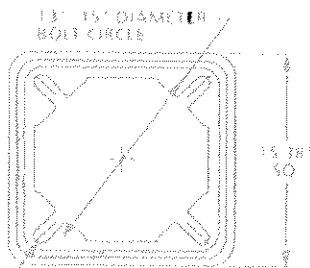

(4) SLOTTED HOLES FOR 1.0\"/>

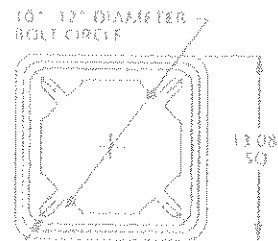

(4) SLOTTED HOLES FOR 1.0\"/>

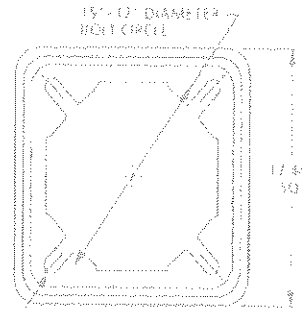

(4) SLOTTED HOLES FOR 1.25\"/>

**Note: For existing A.B. with B.C. (10-1/2" - 12-15/16"), consult factory for modified transformer-base.**



CITY OF FLINT

RESOLUTION STAFF REVIEW FORM

TODAY'S DATE: August 21, 2020

BID/PROPOSAL# 21000551

AGENDA ITEM TITLE: Electrical parts

PREPARED BY Kathryn Neumann for Robert Bincsik, Director of Public Works

VENDOR NAME: McNaughton McKay Electric

BACKGROUND/SUMMARY OF PROPOSED ACTION:

The Traffic Engineering Division, Maintenance Division and Water Service Center are requesting a purchase order for electrical parts on an as needed basis.

FINANCIAL IMPLICATIONS: There is money in the accounts listed below.

BUDGETED EXPENDITURE? YES [X] NO [ ] IF NO, PLEASE EXPLAIN:

Table with 5 columns: Dept., Name of Account, Account Number, Grant Code, Amount. Rows include Major Street Fund, General Fund, Sewer Fund, Water Fund, and a total row for FY21 GRAND TOTAL.

PRE-ENCUMBERED? YES [X] NO [ ] REQUISITION NO: 20003218, 20003244, 20003277

ACCOUNTING APPROVAL: Kirstie Troup Date: 8/21/20

WILL YOUR DEPARTMENT NEED A CONTRACT? YES [ ] NO [X] (If yes, please indicate how many years for the contract) YEARS

OTHER IMPLICATIONS (i.e., collective bargaining):

STAFF RECOMMENDATION: (PLEASE SELECT): [X] APPROVED [ ] NOT APPROVED

DEPARTMENT HEAD SIGNATURE: Robert Bincsik (Robert Bincsik, Director of Public Works)



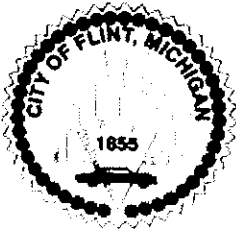

**City of Flint**  
**Department of Finance**  
**Division of Purchases & Supplies**

---

Sheldon A. Neeley

August 19, 2020

**TO:** Jeanette Best  
Krystal Wallace  
John Florshinger  
(WPC)

**FROM:** Joyce A. McClane  
Purchasing Manager 

**SUBJECT:** SEALED BIDS (REBID)

Attached is one (1) bid that was received for **PROPOSAL #21000551 – ELECTRICAL PARTS**. Enclosed are copies for your file. **Bid Due Date: 8/11/20. Enclosed is a spreadsheet.**

Your staff review and recommendation form is needed as soon as possible. **Please use the new fillable form.** This form is to be used for your staff review.

A staff review must be completed for **ALL Bids/Proposals**. Please let me know if you need a copy of the fillable form.

This project has been identified that multiple departments use this item. Please get with those departments to determine the total usage and the amount that needs to go to Council for approval. **This proposal is good for 3 years.**

**Please note:** If your project is being funded by any grants issued by the federal government, you must go to:  
<https://www.dol.gov/ofccp/regs/compliance/preaward/debarlst.htm> to ensure that the selected vendor has not been debarred.

**PLEASE NOTE:**

Results may be viewed next business day online **EXCEPT** when a bid is under review. The bidders/public will only see the names of the bidders that submitted a bid, not their cost. This will protect the bidders cost in case there is a re-bid.

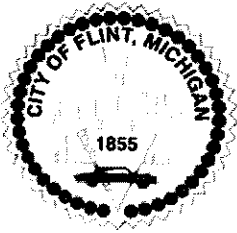

Sheldon A. Neeley

# City of Flint

## Department of Finance

### Division of Purchases & Supplies

---

Today's Date:

Please complete the following form if you decide to rebid:

**Proposal #**

**DETAILED REASON FOR WANTING TO REBID:**

**Authorized Signature and Title:**

**Date Signed**

.....  
**PURCHASING USE ONLY**



SEALED PROPOSALS RECEIVED IN THE DIVISION OF PURCHASES & SUPPLIES  
For (3) YRS – SUPPLY OF ELECTRICAL PARTS  
PROPOSAL #2100551

Approximate Annual Quantities – Not Guaranteed  
Furnish as requested for the period 7/1/20 – 6/30/23

<i>Vendor</i>	<i>1<sup>st</sup> Year</i>	<i>2<sup>nd</sup> Year</i>	<i>3<sup>rd</sup> Year</i>
McNaughton-McKay Electric Company, Flint, MI	\$12,094.21	\$12,094.21	\$12,094.21

**LEAVE BLANK INTENTIONALLY**

## P21000551 – (3) YRS – ELECTRICAL PARTS

**THE FOLLOWING PAGES MUST BE COMPLETED AND INCLUDED WITH SUBMITTAL IN THE FOLLOWING ORDER.**

### **Purchasing Checklist:**

- Cover Sheet
- Complete Proposal Submittal
- Qualifications & License
- List of References
- Certification Regarding Debarment, Suspension, and Other Responsibility Matters
- Proposed Timeline to Complete Work
- All Supporting Documentation - CERTIFICATE OF INSURANCE
- City of Flint, Michigan Affidavit

***Electronic copy MUST be received by Tuesday, August 11, 2020 by 3:00 PM and emailed to PURCHASINGBIDS@CITYOFFLINT.COM.***

***A mailed Hardcopy (UNBOUND) with the original signature MUST be received by Tuesday, August 11, 2020 by 4:30 PM (EST)***

**Mailing Instructions: The City of Flint - Division of Purchases and Supplies  
1101 S. Saginaw Street, Room 203  
Flint, MI 48502**

***Both copies (electronic and mailed copies) must be received to qualify for award recommendation.***

**PROPOSAL #21000551  
ELECTRICAL PARTS SPECIFICATION  
(3) YR BID JULY 1, 2020 THRU JUNE 30, 2023  
City of Flint Water Pollution Control Facilities**

**All proposals will be evaluated on the following criteria:**

1. Failure to use this bid form shall result in bid disqualification.
2. Failure to bid on all items shall result in an "incomplete bid" determination.
3. List value-added considerations on a separate sheet of paper.

**Terms:** NET 30                      **Dest:** FOB                      **Fed. ID#:** 38-0812640

**Firm Name:** MCNAUGHTON - MCKAY ELECTRIC

**Address:** 1011 E. FIFTH AVE

**City/State/Zip** FLINT MI 48503

**Phone:** 8102385611    **Fax:** 8107674126    **Email:** nguyend@mc-mc.com

**Signed:**                       **Date:** 8/10/20

**PROPOSAL #21000551 – ELECTRICAL PARTS**  
**Certification Regarding**  
**Debarment, Suspension, and Other Responsibility Matters**

**BID#:** \_\_\_\_\_

The prospective participant certifies, to the best of its knowledge and belief, that it, its principals, and that of their subcontractor and/ or sub-subcontractors and their principals:

- 1) Are not presently or proposed to be debarred or suspended, declared ineligible, or voluntarily excluded from federal, state, or local (hereinafter "public") transactions;
- 2) Have not within a three-year period preceding this Agreement been convicted of or had a civil judgment rendered against them for
  - i. Fraud or commission of a criminal offense in connection with obtaining, attempting to obtain, or performing a public transaction or contract under a public transaction,
  - ii. Violation of federal or state antitrust laws, or
  - iii. Embezzlement, theft, forgery, bribery, falsification or destruction of records, making false statements or receiving stolen property;
- 3) Have not within the preceding three years had a public transaction terminated for cause or default; and
- 4) Are not presently indicted for or otherwise criminally or civilly charged by a public entity with commission of any of the offenses enumerated under the above.

I understand that a false statement on this certification may be grounds for the rejection of this proposal or the termination of the award

\_\_\_\_\_  
**Name and Title of Authorized Representative**

\_\_\_\_\_  
**Name of Participant Agency or Firm**

\_\_\_\_\_  
**Signature of Authorized Representative**

\_\_\_\_\_  
**Date**

I am unable to certify to the above statement. Attached is my explanation.

**PROPOSAL #21000551 – ELECTRICAL PARTS  
LIST OF REFERENCES: (3) SIMILAR SCOPE OF WORK FROM THE LAST 5 YEARS**

Providing the following contact information enables the City of Flint to contact those accounts as references.

**Reference #1:**

Company/Municipality: \_\_\_\_\_

Contact Person: \_\_\_\_\_ Title: \_\_\_\_\_

Address: \_\_\_\_\_

City: \_\_\_\_\_ State: \_\_\_\_\_ Zip: \_\_\_\_\_

Telephone: \_\_\_\_\_ Fax: \_\_\_\_\_

Email: \_\_\_\_\_

Type of Project: \_\_\_\_\_

Project Timeline (Dates): \_\_\_\_\_ Budget: \_\_\_\_\_

**Reference #2:**

Company/Municipality: \_\_\_\_\_

Contact Person: \_\_\_\_\_ Title: \_\_\_\_\_

Address: \_\_\_\_\_

City: \_\_\_\_\_ State: \_\_\_\_\_ Zip: \_\_\_\_\_

Telephone: \_\_\_\_\_ Fax: \_\_\_\_\_

Email: \_\_\_\_\_

Type of Project: \_\_\_\_\_

Project Timeline (Dates): \_\_\_\_\_ Budget: \_\_\_\_\_



**PROPOSAL #21000551 – ELECTRICAL PARTS**

**Reference #3:**

**Company/Municipality:** \_\_\_\_\_

**Contact Person:** \_\_\_\_\_ **Title:** \_\_\_\_\_

**Address:** \_\_\_\_\_

**City:** \_\_\_\_\_ **State:** \_\_\_\_\_ **Zip:** \_\_\_\_\_

**Telephone:** \_\_\_\_\_ **Fax:** \_\_\_\_\_

**Email:** \_\_\_\_\_

**Type of Project:** \_\_\_\_\_

**Project Timeline (Dates):** \_\_\_\_\_ **Budget:** \_\_\_\_\_

CITY OF FLINT, MICHIGAN AFFIDAVIT

AFFIDAVIT FOR INDIVIDUAL

STATE OF \_\_\_\_\_

S.S.

COUNTY OF \_\_\_\_\_

\_\_\_\_\_ being duly sworn, deposes and says that they are the person making the above bid; and that said bid is genuine and not sham or collusive, and is not made in the interest of or on behalf of any person not therein named, and that they have not directly or indirectly induced or solicited any bidder to put in a sham bid; that they have not directly or indirectly induced or solicited any other person or corporation to refrain from bidding, and that they have not in any manner sought by collusion to secure themselves any advantage over other bidders.

Subscribed and sworn to before me at \_\_\_\_\_, in said County and State, this \_\_\_\_\_ day of \_\_\_\_\_, A.D. 20 \_\_\_\_\_

\*Notary Public, \_\_\_\_\_ County, \_\_\_\_\_

My Commission expires \_\_\_\_\_, 20 \_\_\_\_\_

FOR CORPORATION

STATE OF MI

S.S.

COUNTY OF Wayne

[Signature] 8/10/20

Duc Nguyen being duly sworn, deposes and says that she/he/they

is Asst. Manager of McNaughton-McKay Electric

(Official Title)

(Name of Corporation)

a corporation duly organized and doing business under the laws of the State of MI the corporation making the within and foregoing bid; that they executed said bid in behalf of said corporation by authority of its Board of Directors; that said bid is genuine and not sham or collusive and is not made in the interests of or on behalf of any person not herein named, and that they have not and said bidder has not directly or indirectly induced or solicited any other person or corporation to refrain from bidding; that they have not and said bidder has not in any manner sought by collusion to secure to themselves or to said corporation an advantage over other bidders.

Subscribed and sworn to before me at Canton, in said County and State, this 10 day of August, A.D. 20 20

\*Notary Public, Rupinder Kaur Chawla County, Wayne

My Commission expires 01/23, 2025

RUPINDER KAUR CHAWLA  
NOTARY PUBLIC - STATE OF MICHIGAN  
COUNTY OF WAYNE  
My Commission Expires January 23, 2025  
Act.ing in the County of Wayne

**FOR PARTNERSHIP**

STATE OF \_\_\_\_\_

S.S.

COUNTY OF \_\_\_\_\_

\_\_\_\_\_ being duly sworn, deposes and says that they are a member of the firm of \_\_\_\_\_, a co-partnership, making the above bid; that they are duly authorized to make said bid on behalf of said co-partnership; that said bid is genuine and not sham or collusive, and is not made in the interest of or on behalf of any person not therein named, and that they have and said bidder has not directly or indirectly induced or solicited any other person or corporation to refrain from bidding, and that they have not and said bidder has not in any manner sought by collusion to secure to themselves or to said bidder any advantage over other bidders.

Subscribed and sworn to before me at \_\_\_\_\_, in said County and State,

this \_\_\_\_\_ day of \_\_\_\_\_, A.D. 20 \_\_\_\_\_,

\_\_\_\_\_  
\*Notary Public, \_\_\_\_\_ County, \_\_\_\_\_

My Commission expires \_\_\_\_\_, 20 \_\_\_\_\_

**FOR AGENT**

STATE OF \_\_\_\_\_

S.S.

COUNTY OF \_\_\_\_\_

\_\_\_\_\_ being duly sworn, deposes and says that they executed the within and foregoing bid in behalf of \_\_\_\_\_ the bidder therein named, they having been theretofore lawfully authorized, as the agent of said bidder, so to do; that said bid is genuine and not sham or collusive and not made in the interests of or on behalf of any person not therein named, and that they have not and said bidder has not directly or indirectly induced or solicited any bidder to put in a sham bid; that they have not and said bidder has not directly or indirectly induced or solicited any other person or corporation to refrain from bidding, and that they have not and said bidder has not in any manner sought by collusion to secure to themselves or to said bidder any advantage over other bidders.

Subscribed and sworn to before me at \_\_\_\_\_, in said County and State,

this \_\_\_\_\_ day of \_\_\_\_\_, A.D. 20 \_\_\_\_\_,

\_\_\_\_\_  
\*Notary Public, \_\_\_\_\_ County, \_\_\_\_\_

My Commission expires \_\_\_\_\_, 20 \_\_\_\_\_

*NOTE: If executed outside of the State of Michigan, certificate by the Clerk of the Court of Record, authenticating the Notary's Signature and authority should be attached.*

### CITY OF FLINT REQUEST FOR BID

UPON MUTUAL AGREEMENT BETWEEN THE CITY OF FLINT AND THE SELECTED VENDOR  
 NEW PURCHASE ORDERS WILL BE ISSUED THE BEGINNING OF EACH FISCAL YEAR  
 FURNISH AS REQUESTED WITHIN 48 HOURS NOTICE, BEGINNING 07/01/20 AND ENDING  
 08/30/23.

NO SUBSTITUTIONS FOR ANY ITEM WITH THE MANUFACTURER OF 'SQUARE D'.

DESCRIPTION	MANUFACTURER	1st year	2nd year	3rd year
<b>ASSEMBLY</b>				
193ECPM3 A-B 8085A OVERLOAD MOUNTING	ALLEN-BRADLEY	17.07	17.07	17.07
<b>BALLAST</b>				
GEM296-1S-120-IP - 2-90T12SL 120V	GENERAL ELEC LIGHTING	20.00	20.00	20.00
GE-432-MAX-NULTRA - STD PWR 4LP DUAL VOLT	GENERAL ELEC LIGHTING	15.02	15.02	15.02
GE-232-MAX-NULTRA - STD PWR 2LP DUAL VLT	GENERAL ELEC LIGHTING	11.50	11.50	11.50
GE-232-MAX-LAULTRA - LW PWR 2LMP DUAL VLT	GENERAL ELEC LIGHTING	11.50	11.50	11.50
GE-432-MAX-LAULTRA - LW PWR 4LMP DUAL VLT	GENERAL ELEC LIGHTING	15.02	15.02	15.02
ICF2S26H1LDK ELE BAL (2) 26W CFL (4-PIN)	ADVANCE TRANSFORMER CO	25.00	25.00	25.00
71A5792001D MH BAL 250W M138/M153 QUAD KIT	ADVANCE TRANSFORMER CO	25.00	25.00	25.00
71A5390001D MH BAL 100W M80/140 QUAD KIT	ADVANCE TRANSFORMER CO	25.00	25.00	25.00
RC2S051PM MAG BALLAST (2) F72T12/HO 120V	ADVANCE TRANSFORMER CO	118.85	118.85	118.85
<b>BASE</b>				
QON3B CIRCUIT BREAKER OEM MOUNTING BASE	SQUARE D	1.00	1.00	1.00
700HN125 A-B 8-PIN RELAY	ALLEN-BRADLEY	4.11	4.11	4.11
<b>BATTERY</b>				
RBC8 REPLACEMENT BATT CARTRIDGE	AMERICAN POWER CONV	3.25	3.25	3.25
529 6V ALK PHOTO BATT	ENERGIZER BATT, INC	1.70	1.70	1.70
ALK 9V INDUSTRIAL INDIVIDUAL	RAYOVAC	2.63	2.63	2.63
ALK AA INDUSTRIAL INDIVIDUAL	RAYOVAC	.40	.40	.40
ALK AAA INDUSTRIAL INDIVIDUAL	RAYOVAC	.41	.41	.41
ALK C INDUSTRIAL INDIVIDUAL	RAYOVAC	1.33	1.33	1.33

DESCRIPTION	MANUFACTURER	1st year	2nd year	3rd year
<b>ALK D INDUSTRIAL INDIVIDUAL</b>	RAYOVAC			
928 6V SCREW TRM HD LANTERN BATT	RAYOVAC	1.8	1.8	1.8
KECR2032-1 LITH KYLS ENT BAT CRD 1PK	RAYOVAC	.40	.90	.10
301K 6V LANTERN KRPTN BLB W/BATT8	RAYOVAC	.41	.11	.41
RV1V-HD SPRING TOP BARRICADE	RAYOVAC	1.5	1.5	1.5
		1.54	1.51	1.4
<b>BLOCK</b>				
586AB 1NO/1NC AUX CONTACT	ALLEN-BRADLEY			
193EIMD A-B OVERLOAD RELAY MOUNTING	ALLEN-BRADLEY			
<b>BOARD</b>				
1336L8 A-B 1336-L8 LOGIC	ALLEN-BRADLEY			
<b>BOLT</b>				
8868 5/8X18 DBL ARMING BOLT	HUBBELL POWER SYSTEMS			
<b>BOX</b>				
TP7010 1G WP BOX W/3 1/2 HUBS	CROUSE HINDS			
TP403 4SQ 2-1/8D BOX	CROUSE HINDS			
TP7082 1G WP BOX W/3 1IN HUB	CROUSE HINDS		14	4
TP7018 1G WP BOX W/3 3/4 HUBS	CROUSE HINDS			4
TP288 4 OCT 2-1/8D BOX	CROUSE HINDS			
TP7088 2G WP BOX W/3 1/2 HUB	CROUSE HINDS	8.7	8.81	8.1
HBL2048V RACEWAY 1-G DEV BOX HBL2000 SERIES IV	HUBBELL WIRING DEVICES			
BB201W P+S BOX 20/30A 3/4 ANG ALU	HUBBELL WIRING DEVICES	21.8		11
JB11W-A 1-PIECE JUNCTION BOX	PANDUIT CORP			7.1
54151-1/2 4 OCTAGON BOX SSTL 15.8CU 1/2-KO	THOMAS & BETTS CORP			1
E-14-4 3-1/2X2-3/32-1G SW BXNM14CUOLDWORK	THOMAS & BETTS CORP			
V5747 1G SHALLOW SWARCPT BOX	WIREMOLD CO			
<b>BREAKER</b>				
HOM120 MINI CIRCUIT BREAKER 120/240V 20A	SQUARE D			
QOB150 MINI CIRCUIT BREAKER 120/240V 50A	SQUARE D			

DESCRIPTION	MANUFACTURER	1st year	2nd year	3rd year
QOB130 MINI CIRCUIT BREAKER 120V 30A	SQUARE D	17,500	17,500	17,500
QOB120 MINI CIRCUIT BREAKER 120/240V 20A	SQUARE D	17,500	17,500	17,500
QO120 MINI CIRCUIT BREAKER 120/240V 20A	SQUARE D	7,250	7,250	7,250
QON3B CIRCUIT BREAKER OEM MNTNG BASE	SQUARE D	11,000	11,000	11,000
<b>BULB</b>				
75WT ROUGH SERVICE, RUBBER COATED	? SYLVANIA	1,200	1,200	1,200
LM2A001 AA MINI MAG	? GE	6,500	6,500	6,500
<b>CABLE</b>				
88760 1-PR SHIELDED, PLENUM-RATED	BELDEN	1,600	1,600	1,600
8780 1-PR SHIELDED	BELDEN	1,300	1,300	1,300
<b>CAP</b>				
B1-250JR B1 YELLOW B-CAP 250PC	IDEAL IND	12,972	12,972	12,972
E895G 1-1/4 PVC METER OFFSET	THOMAS & BETTS CORP	13,300	13,300	13,300
E998G-CAR 1-1/4 SVC ENTRANCE CAP	THOMAS & BETTS CORP	2,500	2,500	2,500
SE-CAP-1/2 SERVICE ENTRANCE CAP	?	2,500	2,500	2,500
SE-CAP-1-1/4 SERVICE ENTRANCE CAP	?	2,500	2,500	2,500
<b>CHANNEL</b>				
B228H-10FT-GRN SLOT CHANNEL	COOPER B-LINE SYSTEMS	1,800	1,800	1,800
B228HGRN10 SLOT CHANNEL	COOPER B-LINE SYSTEMS	17,000	17,000	17,000
<b>CLAMP</b>				
B2009 ZN (3/4 GRD) PLTD COND CLAMP	COOPER B-LINE SYSTEMS	7,300	7,300	7,300
B2009-3/4-PLTD COND CLAMP	COOPER B-LINE SYSTEMS	2,000	2,000	2,000
B2010-1-PLTD COND CLAMP	COOPER B-LINE SYSTEMS	12,000	12,000	12,000
RAC75HD 3/4 90D GALV CLAMP	CROUSE HINDS	2,000	2,000	2,000
RAC100HD 1IN 90D GALV CLAMP	CROUSE HINDS	2,000	2,000	2,000
E877GC 1-1/4 2H PVC COND CLAMP	THOMAS & BETTS CORP	2,000	2,000	2,000
CLAMP-PVC-1/2 CONDUIT CLAMP	?	1,000	1,000	1,000
CLAMP-PVC-1-1/4 CONDUIT CLAMP	?	1,000	1,000	1,000

DESCRIPTION	MANUFACTURER	1st year	2nd year	3rd year
<b>CLAMPBACK</b>				
CB2 3/4 MALL CLAMPBACK	CROUSE HINDS			
<b>COIL</b>				
CD236 A-B FOR SIZE 3 STARTER	ALLEN-BRADLEY			
CC236 A-B FOR SIZE 2 STARTER	ALLEN-BRADLEY		3	
CB236 A-B FOR SIZE 1 STARTER	ALLEN-BRADLEY			
<b>CONDUIT</b>				
15007-100 3/4 LT FLEX PVC	THOMAS & BETTS CORP			
1/2-EMT STEEL THINWALL COND	?			
PVC-3 SCH 40 10FT	?			1 1 1 1
PVC-2-1/2 SCH 40 COND 10FT	?			1
1/2 ALUM RIGID CONDUIT	?	1	1 1	1 0 1
PVC-1-1/4 SCH 40 COND 10FT	?			
PVC-2 SCH 40 COND 10FT	?			
3/4-EMT STEEL THINWALL COND	?			1
2-GALV RIGID CONDUIT	?	2	1 1	
1-1/2 GALV RIGID CONDUIT	?			
PVC-1 SCH 40 COND 10FT	?			
PVC-3/4 SCH 40 COND 10FT	?			
1-ALUM RIGID CONDUIT	?	1 1 1 1	1 1 1	1
3/4-ALUM RIGID CONDUIT	?	1		
<b>CONDULET</b>				
C25 3/4 ALUM C COND BODY	CROUSE HINDS			
T25 3/4 ALUM T COND BODY	CROUSE HINDS		1	
LR25-CGN 3/4 RGD LR COND BODY CVR&GSK ALM	CROUSE HINDS			
LB25 3/4 ALUM LB COND BODY	CROUSE HINDS	1		
LB15 1/2 ALUM LB COND BODY	CROUSE HINDS			1
T15 1/2 ALUM T COND BODY	CROUSE HINDS	1		1
E987G-CAR 1-1/4 C PVC BODY	THOMAS & BETTS CORP	1 2	1 1	
LB2-1/2 COND BODY TYPE LB	?			
C-1-1/4 COND BODY TYPE C	?			

DESCRIPTION	MANUFACTURER	1st year	2nd year	3rd year
<b>CONNECTOR</b>				
O/B+JUG SPRING CONNECTOR ORANGE/BLUE	3M IND TAPE DIV	13.00	13.00	13.00
T/Y+JUG SPRING CONNECTOR TANYELLOW	3M IND TAPE DIV	12.00	12.00	12.00
O/B-BULK-PLUS SPRING CONN ORANGE/BLUE	3M IND TAPE DIV	10.25	10.25	10.25
30-273 SIZE 73B ORG WIRE CONN	IDEAL IND	20.52	20.52	20.52
30-652 SIZE 452 RED WIRE CONN	IDEAL IND	20.52	20.52	20.52
30-073 SIZE 73B ORG WIRE CONN	IDEAL IND	10.25	10.25	10.25
30-072 SIZE 72B BLU WIRE CONN	IDEAL IND	8.57	8.57	8.57
30-074 SIZE 74B YEL WIRE CONN	IDEAL IND	11.62	11.62	11.62
30-078 SIZE 78B RED WIRE CONN	IDEAL IND	18.02	18.02	18.02
30-661 SIZE 451 YEL WIRE CONN	IDEAL IND	23.68	23.68	23.68
BSN10-L NYLON-INS BUTT SPLICE	PANDUIT CORP	29.01	29.01	29.01
BSN14-C NYLON-INS BUTT SPLICE	PANDUIT CORP	28.77	28.77	28.77
BSN18-C NYLON-INS BUTT SPLICE	PANDUIT CORP	28.77	28.77	28.77
BSV10X-L VINYL-INS BUTT SPLICE	PANDUIT CORP	50.51	50.51	50.51
BSV14X-C VINYL-INS BUTT SPLICE	PANDUIT CORP	28.77	28.77	28.77
BSV18X-CY VINYL BUTT SPLICE	PANDUIT CORP	21.04	21.04	21.04
C205-0211 CONNECTOR	?	5.35	5.35	5.35
<b>CONTACTOR</b>				
89298X6 CONTACTOR+STARTER AUX CONT	SQUARE D	97.02	97.02	97.02
<b>COUPLING</b>				
480 1/2 STL S/SCR EMT	CROUSE HINDS	.57	.57	.57
191 3/4 MALL 3PC COND CPLG	CROUSE HINDS	.73	.73	.73
193 1-1/4 MALL 3PC COND CPLG	CROUSE HINDS	1.03	1.03	1.03
COUP-2 SCH40	?	.41	.41	.41
COUP-3 SCH40	?	1.18	1.18	1.18
3/4-ALUM-COND COUPLING	?	.70	.70	.70
50980D A-B SIZE 1	ALLEN-BRADLEY	620.00	620.00	620.00
50980D A-B SIZE 2	ALLEN-BRADLEY	620.00	620.00	620.00
<b>COVER</b>				
TP7240 1G WP GFI DEVICE COVER	CROUSE HINDS	.65	.65	.65



DESCRIPTION	MANUFACTURER	1st year	2nd year	3rd year
DS100G SNGL GN BLANK CST ALUM W/GASKET	CROUSE HINDS	11.50	11.50	11.50
TP472 4SQ FLAT BLANK COVER	CROUSE HINDS	11.00	11.00	11.00
TP808 BLANK UTILITY COVER	CROUSE HINDS	11.00	11.00	11.00
TP7199 1G WP DPLX RCPT COVER	CROUSE HINDS	11.04	11.04	11.04
TP7207 1G WP DPLX RCPT COVER	CROUSE HINDS	11.03	11.03	11.03
TP7202 1G WP SGL RCPT COVER	CROUSE HINDS	11.04	11.04	11.04
TP7218 1G WP SGL RCPT COVER	CROUSE HINDS	11.03	11.03	11.03
250 3/4 ALUM COND BODY COVER	CROUSE HINDS	11.07	11.07	11.07
TP7252 2G WP GFI DEVICE COVER	CROUSE HINDS	11.03	11.03	11.03
SS8 WALLPLATE 1-G DUP SS	HUBBELL WIRING DEVICES	11.00	11.00	11.00
SS1 WALLPLATE 1-G SWITCH SS	HUBBELL WIRING DEVICES	11.00	11.00	11.00
SS8 WALLPLATE 1-G DUP SS	HUBBELL WIRING DEVICES	11.00	11.00	11.00
11699 BLANK COVER 1/2IN	MULBERRY METAL PROD	11.07	11.07	11.07
11700 BLANK COVER 3/4"	MULBERRY METAL PROD	11.07	11.07	11.07
WDGF100-C 2 GANG DUPLEX GFI	THOMAS & BETTS CORP	11.00	11.00	11.00
<b>FLASHLIGHT</b>				
M2A01H MINI-MAG WITH HOLSTER	?	11.00	11.00	11.00
<b>FIXTURE</b>				
RCL-80E 80W INDUCTION ROUND CANOPY	MHT	11.00	11.00	11.00
RCK40E INDUCTION	MHT	11.00	11.00	11.00
<b>FUSE</b>				
OMM-B-44/100 FUSE	COOPER BUSSMANN, INC	11.00	11.00	11.00
FRN-R-25 FUSETRON DUAL-ELEMENT CLASS RK5	COOPER BUSSMANN, INC	11.00	11.00	11.00
FR5-R-1/4 FUSETRON DUAL ELEMENT CLASS R	COOPER BUSSMANN, INC	11.00	11.00	11.00
FNQ-R-1 CLASS CC TIME DELAY	COOPER BUSSMANN, INC	11.00	11.00	11.00
NON-3 BUSS ONE TIME FUSE	COOPER BUSSMANN, INC	11.00	11.00	11.00
GMA-100MA BUSS SMALL DIMENSION FUSE	COOPER BUSSMANN, INC	11.00	11.00	11.00
170M5810 SQ BDY SEMI-COND FUSE	COOPER BUSSMANN, INC	11.00	11.00	11.00
ATRO2 FERRAZ ATRO2, 2A	GOULD	11.00	11.00	11.00
ATRO1 FERRAZ ATRO1, 1A	GOULD	11.00	11.00	11.00
ATRO3 1/2 FERRAZ ATRO3-1/2, 3-1/2A	GOULD	11.00	11.00	11.00

DESCRIPTION	MANUFACTURER	1st year	2nd year	3rd year
ATRO5 FERRAZ ATRO5, 5A	GOULD	2,50	2,50	2,50
FNM1 BUSSMAN	BUSSMAN	8,50	8,50	8,50
KTKR10 BUSSMAN	BUSSMAN	15,00	15,00	15,00
GMA-1A BUSS SMALL DIMENSION FUSE	COOPER BUSSMANN, INC	1,00	1,00	1,00
FR5-R7 FUSETRON DUAL ELEMENT CLASS R	COOPER BUSSMANN, INC	15,00	15,00	15,00
FRN-R60 FUSETRON DUAL ELEMENT CLASS RK5	COOPER BUSSMANN, INC	10,00	10,00	10,00
GDE-1107	?	2,00	2,00	2,00
70-065-065.5 SIBA FUSE 5 AMP 500VOLT	?	2,25	2,25	2,25
<b>GASKET</b>				
11721 3/4 COND BODY GASKET	MULBERRY METAL PROD	.73	.73	.73
11720 1/2 COND BODY GASKET	MULBERRY METAL PROD	.57	.57	.57
<b>LAMP</b>				
F48T12/CW 48IN SLIMLINE CW LAMP	GENERAL ELEC LIGHTING	3,50	3,50	3,50
F32T8/SP41/ECO FLOURESCENT LAMP	GENERAL ELEC LIGHTING	2,25	2,25	2,25
F85T12/CW/WM15PK 85IN SLIM LAMP	GENERAL ELEC LIGHTING	4,01	4,01	4,01
MVR250UJ MULTI-VAPOR E28 CLEAR LAMP	GENERAL ELEC LIGHTING	10,95	10,95	10,95
MVR175UJ MULTI-VAPOR E28 CLEAR LAMP	GENERAL ELEC LIGHTING	8,89	8,89	8,89
100A48PK120 A19 MED IP LAMP	GENERAL ELEC LIGHTING	3,20	3,20	3,20
F85T12/CW/HO/WM15PK LAMP	GENERAL ELEC LIGHTING	3,75	3,75	3,75
F95T12/CW/WM/ECO FLOURESCENT LAMP	GENERAL ELEC LIGHTING	2,75	2,75	2,75
FLE26HT3/28Z7 COMPACT FLOURESCENT LAMP	GENERAL ELEC LIGHTING	4,11	4,11	4,11
R34CW/RS/WM/ECO	GENERAL ELEC LIGHTING	2,80	2,80	2,80
RF24T12/CW/HO 24IN HI-OUT WHITE LAMP	GENERAL ELEC LIGHTING	13,20	13,20	13,20
F35CWAJ/BAWM	GENERAL ELEC LIGHTING	2,40	2,40	2,40
F260BX/841/ECO4P COMPACT FLOUR ECO LAMP	GENERAL ELEC LIGHTING	4,53	4,53	4,53
MVR100UJ/MED MH LAMP	GENERAL ELEC LIGHTING	14,00	14,00	14,00
Q500T3JCL120 QTZ LAMP	GENERAL ELEC LIGHTING	2,21	2,21	2,21
MVR400UJ MULTI-VAPOR E37 LAMP	GENERAL ELEC LIGHTING	2,01	2,01	2,01
MVR70UJ/MED MH LAMP	GENERAL ELEC LIGHTING	10,35	10,35	10,35
F260BT4/SPX41 FLOURESCENT LAMP	GENERAL ELEC LIGHTING	4,03	4,03	4,03
F32T8/SPX41/ECO FLOURESCENT LAMP	GENERAL ELEC LIGHTING	3,15	3,15	3,15
F24T12/CW/HO 24IN HI-OUT WHITE LAMP	GENERAL ELEC LIGHTING	2,90	2,90	2,90
100A/S-120V-24PK120 CAND LAMP	GENERAL ELEC LIGHTING	1,10	1,10	1,10

DESCRIPTION	MANUFACTURER	1st year	2nd year	3rd year
75A/67WM120 67W WATT-MISER LAMP	GENERAL ELEC LIGHTING	1.15	1.15	1.15
100AW/LL24PK120 41280 A-LINE INCANDESCENT	GENERAL ELEC LIGHTING	1.12	1.12	1.12
FLE28Q8X/A/627 FLOURESCENT LAMP	GENERAL ELEC LIGHTING	1.12	1.12	1.12
F13D8X23T4/SPX35 D8L BIAX LAMP	GENERAL ELEC LIGHTING	1.12	1.12	1.12
65R30/FL/M-8PK120 FLOOD LAMP	GENERAL ELEC LIGHTING	1.12	1.12	1.12
F96T/SP41 FLOURESCENT LAMP	GENERAL ELEC LIGHTING	1.12	1.12	1.12
F17T/SP41/ECO FLOURESCENT LAMP	GENERAL ELEC LIGHTING	1.12	1.12	1.12
F34CW/RSMW/ECO	GENERAL ELEC LIGHTING	1.12	1.12	1.12
F48T12/CW/HO 48IN HI-OUT WHITE LAMP	GENERAL ELEC LIGHTING	1.12	1.12	1.12
LU250 HPS LUCALOX 250W LAMP	GENERAL ELEC LIGHTING	1.12	1.12	1.12
765UNIT T3-1/4 MINI BAY 6.3 LAMP	GENERAL ELEC LIGHTING	1.12	1.12	1.12
6S8TRAY120 S8 CAND CLEAR LAMP	GENERAL ELEC LIGHTING	1.12	1.12	1.12
F28DBXT4SPX41/4P FLOURESCENT LAMP	GENERAL ELEC LIGHTING	1.12	1.12	1.12
F32T8/SP35/ECO FLOURESCENT LAMP	GENERAL ELEC LIGHTING	1.12	1.12	1.12
1950LP25/T5130 TRAFFIC SIGNAL LAMP	GENERAL ELEC LIGHTING	1.12	1.12	1.12
69A21/T5130 A21 MED LAMP	GENERAL ELEC LIGHTING	1.12	1.12	1.12
69A21/T8120 A21 MED LAMP	GENERAL ELEC LIGHTING	1.12	1.12	1.12
LU150/55 HPS LUCALOX 2000 LAMP	GENERAL ELEC LIGHTING	1.12	1.12	1.12
FLE20HT3/2/XL CFL LAMP 20W X-LONG LIFE	GENERAL ELEC LIGHTING	1.12	1.12	1.12
F35T12/D/HO 36IN HO DAYLIGHT LAMP	GENERAL ELEC LIGHTING	1.12	1.12	1.12
QF500 500W QTZ FLOOD W/LP	RAB ELEC MFG CO INC	1.12	1.12	1.12
MP250W/BU/UNV3/PS 64658	VENTURE LIGHTING	1.12	1.12	1.12
MS175/BU/PS 68475	VENTURE LIGHTING	1.12	1.12	1.12
MH100W/PS 27266	VENTURE LIGHTING	1.12	1.12	1.12
WP40E INDUCTION WALL-PAK 40W	MHT	1.12	1.12	1.12
WP80E INDUCTION WALL-PAK 80W	MHT	1.12	1.12	1.12
RCL40E INDUCTION ROUND CANOPY 40W	MHT	1.12	1.12	1.12
<b>LIGHT</b>				
800HQT10G A-B LED PILOT, GREEN, 120V	ALLEN-BRADLEY	1.12	1.12	1.12
<b>LOCKNUT</b>				
1-1/4 STEEL LOCKNUT	CROUSE HINDS			1.12
3IN STEEL LOCKNUT	CROUSE HINDS			1.12
1IN STEEL LOCKNUT	CROUSE HINDS			1.12

DESCRIPTION	MANUFACTURER	1st year	2nd year	3rd year
1-1/2 STEEL LOCKNUT	CROUSE HINDS	1.70	1.70	1.70
PSL-1A JAW LOCKNUT	PANOUT CORP	1.25	1.25	1.25
<b>MODULE</b>				
100DNY41R 120V DSA	ALLEN-BRADLEY	350.20	350.20	350.20
100DNY42R 24V DSA	ALLEN-BRADLEY	350.20	350.20	350.20
<b>OVERLOAD</b>				
592EC2CC A-B E3+ 5-25A	ALLEN-BRADLEY	875.80	875.80	875.80
582EC2BC E3+ 3-15A	ALLEN-BRADLEY	875.80	875.80	875.80
582EC2DC 8-45A	ALLEN-BRADLEY	875.80	875.80	875.80
<b>PHOTO CONTROL</b>				
K4123C 208-277 V 50/60 HZ 3100-4100 WATT	INTERMATIC INC	15.03	15.03	15.03
LC4521C 120V 50/60 HZ 1000WATT INTIN LOCKING	INTERMATIC INC	2.10	2.10	2.10
K4121C 120V 50/60HZ 1800WATT INTIN STEM MOU	INTERMATIC INC	9.82	9.82	9.82
K4221C 120V50/60 HZ 1800WATT INTIN SWIVEL M	INTERMATIC INC	10.51	10.51	10.51
3000 120V 1500W SPST FLUSH MOUNTING	TORK, INC	25.87	25.87	25.87
2101 120V 2000W SPST CONDUIT COUJNT DIE CAST	TORK, INC	25.87	25.87	25.87
5001S 105-130V 1200W DELAYED RESPONSE	TORK, INC	19.01	19.01	19.01
<b>PLUG</b>				
HBL214158 H/LOCK PLUG 3P4W 30A 600V	HUBBELL WIRING DEVICES	105.61	105.61	105.61
HBL5085VY VALISE PLUG 15A 125V 5-15P YL	HUBBELL WIRING DEVICES	5.03	5.03	5.03
HBL5269C PLUG 15A 125V 5-15P 0/W	HUBBELL WIRING DEVICES	11.73	11.73	11.73
HBL2311SW LKG WT 3/SHRD 20A 125V L5-20P	HUBBELL WIRING DEVICES	50.50	50.50	50.50
94215405 A-B DEVICENET	ALLEN-BRADLEY	1500.20	1500.20	1500.20
<b>PUSH BUTTON</b>				
ZB4BH02 FLUSH PUSH ON/PUSH OFF NON-ILLUM BLACK	SQUARE D	13.75	13.75	13.75
ZB4BZ105 BLK ASSM	SQUARE D	5.07	5.07	5.07
XAPG19201 PUSHBUTTON ENCLOSURE 30MM XAP +OPTIONS	SQUARE D	3.11	3.11	3.11

DESCRIPTION	MANUFACTURER	1st year	2nd year	3rd year
<b>RECEPTACLE</b>				
CT5382I PLT SCR ASSMT	HUBBELL WIRING DEVICES	218	218	218
CR5362 DUP RCPT CONST GRD 20A125V 5-20R BR	HUBBELL WIRING DEVICES	4	4	4
CR20I DUP RCPT COMM GRD 20A 125V 5-20R IV	HUBBELL WIRING DEVICES	4	4	4
HBL2315 LKG PLG-INLT 20A 125V L5-20P WH	HUBBELL WIRING DEVICES		7	
GFR5352A GFCI RCPT COMM GRD20A 125V5-20R	HUBBELL WIRING DEVICES			
GFR5352A GFCI RCPT COMM GRF20A 125V5-20R	HUBBELL WIRING DEVICES			
HBL5286C PLUG 15A 125V 5-15P B/W	HUBBELL WIRING DEVICES		1	1
CR5382W DUP RCPT CONST GRD 20A125V 5-20R	HUBBELL WIRING DEVICES			
GFR5352L 20A 125V COMM GFCI BRWN LED	HUBBELL WIRING DEVICES			
HBL20405 W/PROOF COVER FOR HBL20403/20443	HUBBELL WIRING DEVICES	15	1	
7401008 STR MALE DCG .37-50 1/2 W/MESH	HUBBELL WIRING DEVICES	U		U
CR5382I STD PWR 4LP DUAL VLT BLST	HUBBELL WIRING DEVICES	75		
49686-I TAP	LEVITON MANU			
<b>RELAY</b>				
8501KP12V20 RELAY 240VAC 10AMP TYPE K PLUS OPTIONS	SQUARE D	200	200	200
8501KP12P14V20 RELAY 240VAC 10AMP TYPE K PLUS OPTIONS	SQUARE D	200	200	200
8501DPD12P14V53 RELAY 240VAC 10AMP TYPE K PLUS OPTIONS	SQUARE D	200	200	200
8501KP12V14 RELAY 240VAC 10AMP TYPE K PLUS OPTIONS	SQUARE D	200	200	200
8501NR51 RELAY SOCKET 600VAC 10A TYPE K PLUS OPTIONS	SQUARE D	200	200	200
8501NR61 RELAY SOCKET 600VAC 5A TYPE K PLUS OPTIONS	SQUARE D	200	200	200
8501NR51B RELAY SOCKET 600VAC 10A TYPE K PLUS OPTIONS	SQUARE D	200	200	200
700CF400D 4NO INDUSTRIAL CONTROL	ALLEN-BRADLEY			
700HA32A2434 A-B GEN PURP. 24VDC, DPDT	ALLEN-BRADLEY		4	
700HA32A134 A-B GEN PURP. 120VAC, DPDT	ALLEN-BRADLEY		5	

DESCRIPTION	MANUFACTURER	1st year	2nd year	3rd year
<b>SEAL</b>				
AS075 3/4 OT KO SEAL	HOFFMAN ENG	10.82	10.82	10.82
AS100 1IN OT KO SEAL	HOFFMAN ENG	17.77	17.77	17.77
AS150 1-1/2 OT KO SEAL	HOFFMAN ENG	16.125	16.125	16.125
AS200 2IN OT KO SEAL	HOFFMAN ENG	17.86	17.86	17.86
AS300 3IN OT KO SEAL	HOFFMAN ENG	25.10	25.10	25.10
<b>STRAP</b>				
200 1/2 1H STL EMT STRAP	CROUSE HINDS	7.60	7.60	7.60
498-3 1/2 RGD 2 HOLE STRAP	CROUSE HINDS	16.51	16.51	16.51
498-4 3/4 RGD 2 HOLE STRAP	CROUSE HINDS	16.76	16.76	16.76
511 3/4 1H MALL CONO STRAP	CROUSE HINDS	3.01	3.01	3.01
B2008SS4 1/2" RIGID STAINLESS STEEL STRUT	B-LINE	1.50	1.50	1.50
B2008SS4 1/4" RIGID STAINLESS STEEL STRUT	B-LINE	4.24	4.24	4.24
B2010SS4 1" RIGID STAINLESS STEEL STRUT	B-LINE	5.08	5.08	5.08
<b>STRUT</b>				
B228H120884 B-LINE STAINLESS STEEL	B-LINE	186.94	186.94	186.94
<b>SWEEP</b>				
ELL-80-3 8CH40	?	13.64	13.64	13.64
ELL-80-2 8CH40	?	16.77	16.77	16.77
ELL-45-3 8CH40	?	15.84	15.84	15.84
ELL-80-1 8CH40	?	11.77	11.77	11.77
<b>SWITCH</b>				
C81222 DP TOG CONST GRD 20A 120/277V BR	HUBBELL WIRING DEVICES	9.15	9.15	9.15
C51221I SP TOG CONST GRD 20A 120/277V IV	HUBBELL WIRING DEVICES	7.51	7.51	7.51
C51201 SP TOG SPC GRADE 20A 120/277V IV	HUBBELL WIRING DEVICES	1.90	1.90	1.90
C51221W SP TOG CONST GRD 20A 120/277V WH	HUBBELL WIRING DEVICES	2.20	2.20	2.20
H8L1221 SP TOG IND GRD 20A 120/277V BR	HUBBELL WIRING DEVICES	2.53	2.53	2.53
H8L1222 DP TOG IND GRD 20A 120/277V BR	HUBBELL WIRING DEVICES	2.60	2.60	2.60
A800HJR2 A-B 800H 3-POS SELECTOR	ALLEN-BRADLEY	60.92	60.92	60.92

DESCRIPTION	MANUFACTURER	1st year	2nd year	3rd year
<b>SUPPRESSOR</b>				
592KD4 A-B K04 SURGE	ALLEN BRADLEY	47,000	47,000	47,000
<b>TAPE</b>				
33-SUPER-3/4X66FT VINYL TAPE	3M IND TAPE DIV	1,200	1,200	1,200
130C-3/4X30FT LINERLESS RUBBER TAPE	3M IND TAPE DIV	1,200	1,200	1,200
66-SUPER-3/4X66FT TAPE	3M IND TAPE DIV	1,200	1,200	1,200
1700-3/4X66FT-1 5 CORE TAPE	3M IND TAPE DIV	4	4	8
68T 3/4X80FT VINYL TAPE	3M IND TAPE DIV	4	4	4
2200-6-1/2X4-12 VINYL MASTIC TAPE	3M IND TAPE DIV	4	4	4
ITS-20R0 TAK-TAPE 20FT ROLL	PANDUIT CORP	54	54	54
<b>TERMINAL</b>				
PV14-6F-C FORK TERM NAL	PANDUIT CORP	100	100	100
DV14-250MB-C DISCONNECT	PANDUIT CORP	100	100	100
DV18-250MB-CY DISCONNECT	PANDUIT CORP	100	100	100
DNFR14-250FIB-C DISCONNECT	PANDUIT CORP	100	100	100
DV10-250-L DISCONNECT	PANDUIT CORP	100	100	100
PV18-6F-CY TERM FORK VINYL INS	PANDUIT CORP	100	100	100
PN10-14F-L FORK TERMINAL	PANDUIT CORP	100	100	100
PV14-P47-C TERMINAL	PANDUIT CORP	100	100	100
PV14-6F-C FORK TERMINAL	PANDUIT CORP	100	100	100
DV14-250B-C DISCONNECT	PANDUIT CORP	100	100	100
DV18-250B-CY DISCONNECT FEMALE VINYL	PANDUIT CORP	100	100	100
PN10-14R-L RING TERMINAL	PANDUIT CORP	100	100	100
DV18-250B-C FEM DISCONNECT BULK-PK	PANDUIT CORP	100	100	100
RB14-6F 16-14 INS SPADE	THOMAS & BETTS CORP	100	100	100
RA18-6F 22-18 INS SPADE	THOMAS & BETTS CORP	100	100	100
RA18-10F INS NYL FORK TERM 22-18 #10 RED	THOMAS & BETTS CORP	100	100	100
3044571 UT 4-QUATTRO	PHOENIX	100	100	100
3044102 UT 4	PHOENIX	100	100	100
<b>TIMER</b>				
SLA-460-AFE	AUTOMATIC TIMING & CNTRL	65,77	65,77	65,77

DESCRIPTION	MANUFACTURER	1st year	2nd year	3rd year
ST01C 7 DAY PROG DIG WALL SWITCH TIMER	INTERMATIC INC	25.24	25.24	25.24
WP1030MC CLAM PACK 2 GANG OR 1 GANG 3-1/8"	INTERMATIC INC	20.00	20.00	20.00
ET104C NEMA 1-120-277V 50/60 HZ DPST	INTERMATIC INC	105.11	105.11	105.11
T101 NEMA 1-125 V SPST	INTERMATIC INC	48.71	48.71	48.71
3000 120V 1500W SPST FLUSH MOUNTING	TORK, INC	23.82	23.82	23.82
<b>TRANSFORMER</b>				
1497C8ASXON A-B 130VA CONTROL	ALLEN-BRADLEY	66.95	66.95	66.95
<b>UNIT</b>				
1201HA2 A-B LCD DRIVE PROGRAMMER	ALLEN-BRADLEY	51.22	51.22	51.22
5803593 PLC-RSC-120UC/21/SO48 CONTACT	PHOENIX	5.70	5.70	5.70
2880319 PLC-BSC-120UC/21/SO48 BASE	PHOENIX	8.10	8.10	8.10
2981118 REL-MR-600C-21 RELAY	PHOENIX	15.23	15.23	15.23
<b>WIRE</b>				
SOOW-10-4-BLK-250CN 90DEG C 600V	?	1.01	1.01	1.01
THHN-8-STR-BLK-5000R 19 STRND 600V 90DEG CU	?	1.22	1.22	1.22
THHN-3-STR-BLK-5000R 19 STRND 600V 90DEG CU	?	1.40	1.40	1.40
THHN-6-STR-GRN-500S 19STR 600V 90DE CU	?	22.63	22.63	22.63
THHN-12-STR-BLK-500S 19STR 600V 90DE CU	?	104.96	104.96	104.96
THHN-12-STR-WHT-500S 19STR 600V 90DE CU	?	104.96	104.96	104.96
THHN-12-STR-GRN-500S 19STR 600V 90DE CU	?	104.96	104.96	104.96
TFFN-18-STR-RED-500S 28STR 600V 90DE CU	?	29.88	29.88	29.88
THHN-12-STR-RED-500S 19STR 600V 90DE CU	?	104.96	104.96	104.96
THHN-8-STR-GRN-500S 19STR 600V 90DE CU	?	132.46	132.46	132.46
THHN-8-STR-BLK-5000R 19 STR 600V 90DE CU	?	132.46	132.46	132.46
THHN-10-STR-BLK-500S 19 STR 600V 90DE CU	?	150.35	150.35	150.35
THHN-10-STR-RED-500S 19 STR 600V 90DE CU	?	150.35	150.35	150.35
THHN-10-STR-GRN-500S 19 STR 600V 90DE CU	?	150.35	150.35	150.35
TFFN-18STR-WHT-500S 28 STR 600V 90DE CU	?	60.20	60.20	60.20
TFFN-18-STR-YEL-500S 28 STR 600V 90DE CU	?	60.20	60.20	60.20
TFFN-18-STR-GRY-500S 28 STR 600V 90DE CU	?	60.20	60.20	60.20
TFFN-18-STR-BLU-500S 28 STR 600V 90DE CU	?	60.20	60.20	60.20



DESCRIPTION	MANUFACTURER	1st year	2nd year	3rd year
TFFN-16-STR-RED-500S 26 STR 600V 90DE CU	?	10,200	10,200	10,200
TFFN-16-STR-ORN-500S 26 STR 600V 90DE CU	?	10,200	10,200	10,200
THHN-14-STR-BLK-500S 19 STR 600V 90DE CU	?	7,041	7,041	7,041
THHN-14-STR-WHT-500S 19 STR 600V 90DE CU	?	7,041	7,041	7,041
THHN-14-STR-GRN-500S 19 STR 600V 90DE CU	?	7,041	7,041	7,041
THHN-12-SOL-BLU-2500R SOLID COND 600V 90DE	?	116,374	116,374	116,374
BARE-CU-SD-6-75TR-315S	?	13,200	13,200	13,200
20-4-TRAFFIC CABLE (601340)	?	15,011	15,011	15,011
2C16FS-CMP-NA-RFA-BED 6300FE 8771000	BELDEN	1,200	1,200	1,200
4C16FS-CMP-NA-RFA-BED 6302FE 877U1000	BELDEN	1,200	1,200	1,200
RG6-NP-60-PA-FN-R-BED 9116 0101000	BELDEN	1,170	1,170	1,170
IMSA14-12/20-1-STR3500R 601200 0105000	BELDEN	1,200	1,200	1,200
IMSA 14-7/26-1-STR-5K-BED	BELDEN	1,200	1,200	1,200
IMSA 14-7/26-1	HOUSTON WIRE & CABLE	1,200	1,200	1,200
IMSA 20-1 14GA 9 COND STRD	HOUSTON WIRE & CABLE	1,170	1,170	1,170
IMSA 20-1 STRAND 12GA3COND	HOUSTON WIRE & CABLE	1,170	1,170	1,170
IMSA 20-1 STRAND 6 GA 2 COND	HOUSTON WIRE & CABLE	1,170	1,170	1,170
IMSA 20-1 STRAND 14GA 7 COND	HOUSTON WIRE & CABLE	1,170	1,170	1,170
IMSA 20-1 14/16 STR	HOUSTON WIRE & CABLE	1,170	1,170	1,170
14-07-STRM SA20-1	HOUSTON WIRE & CABLE	1,170	1,170	1,170
IM2011477	OMNI CABLE CORP	1,170	1,170	1,170
IMSA 20-1 14GA/12G STRANDED	OMNI CABLE CORP	1,170	1,170	1,170
IMSA 20-1 12/3 STR	OMNI CABLE CORP	1,170	1,170	1,170
IM2010802	OMNI CABLE CORP	1,170	1,170	1,170
5EBSWF-4P24-R-5K-ESS 04-003-54	SUPERIOR ESSEX COMM	1,170	1,170	1,170
3P2P24-GY-P-ESS-PP 18-041-38	SUPERIOR ESSEX COMM	1,170	1,170	1,170
<b>WIRE CONNECTOR</b>				
0VB+JUG SPRING CONN ORANGE/BLUE (JUG)	3M IND TAPE D V	1,170	1,170	1,170
17Y+JUG SPRING CONN TAN/YELLOW (JUG)	3M IND TAPE D V	1,170	1,170	1,170
30-852 SIZE 452 RED WIRE CONN	3M IND TAPE DIV	1,170	1,170	1,170
30-851 SIZE 451 YELLOW WIRE CONN	3M IND TAPE DIV	1,170	1,170	1,170
30-273 SIZE 738 ORANGE WIRE CONN	3M IND TAPE DIV	1,170	1,170	1,170
30-074 SIZE 748 YELLOW WIRE CONN	3M IND TAPE DIV	1,170	1,170	1,170
30-454 SIZE 454 BLUE WIRE CONN	3M IND TAPE DIV	1,170	1,170	1,170

DESCRIPTION	MANUFACTURER	1st year	2nd year	3rd year
B1-250JR B1 YELLOW 8-CAP	3M IND TAPE DIV / 100	11.91	11.91	11.91
30-073 SIZE 73B ORANGE WIRE CONN	3M IND TAPE DIV / 100	9.20	9.20	9.20
30-072 SIZE 72B BLUE WIRE CONN	3M IND TAPE DIV / 100	9.20	9.20	9.20
30-076 SIZE 76B RED WIRE CONN	3M IND TAPE DIV / 100	17.05	17.05	17.05

VENDOR TO COMPLETE THIS SECTION - TOTAL PER YEAR ----->

\$ 12,094.2 | \$ 12,094.21 | \$ 12,094.21



RESOLUTION NO.: 210258  
 PRESENTED: JUN - 6 2021  
 ADOPTED: \_\_\_\_\_

PROPOSAL# 20-514

BY THE CITY ADMINISTRATOR:

**RESOLUTION TO ACE-SAGINAW PAVING CO. FOR ADDITIONAL ASPHALT PAVING MATERIALS**

WHEREAS, the Water and Sewer divisions use CP6 cold patching materials for temporary repairs to the water and sewer systems. These divisions recommend to extend the contract with Ace Saginaw Asphalt for additional asphalt paving materials.

Account Number	Account Name	Amount
590-540.208-782.000	Asphalt - Outside	\$6,150.00
591-540.202-782.000	Asphalt - Outside	850.00
591-540.202-752.000	Supplies	4,000.00
	<b>FY2021 GRAND TOTAL</b>	<b>\$11,000.00</b>

IT IS RESOLVED, that the appropriate City Officials are authorized to do all things necessary to extend the contract with Ace Saginaw Asphalt to provide additional asphalt paving materials for FY2021 for the amount of \$11,000.00 and a contract total amount of \$793,188.00 under the same terms and conditions.

APPROVED AS TO FORM:

Angela Wheeler  
Angela Wheeler (May 25, 2021 17:34 EDT)  
 Angela Wheeler, Chief Legal Officer

APPROVED AS TO FINANCE:

Shelbi Frayer  
shelbi frayer (May 26, 2021 09:04 EDT)  
 Shelbi Frayer, Chief Financial Officer

FOR THE CITY OF FLINT:

CLYDE D EDWARDS  
CLYDE D EDWARDS (May 27, 2021 13:33 EDT)  
 Clyde Edwards, City Administrator

APPROVED BY CITY COUNCIL:

\_\_\_\_\_  
 Kate Fields, City Council President

APPROVED AS TO PURCHASING:

Jennifer Ryan  
Jennifer Ryan (May 23, 2021 15:26 EDT)  
 Jenn Ryan, Deputy Finance Director



CITY OF FLINT

RESOLUTION STAFF REVIEW FORM

TODAY'S DATE: 04/21/21

BID/PROPOSAL#

AGENDA ITEM TITLE: Cold Patch

PREPARED BY Bonnie Duncan, Utilities

VENDOR NAME: Ace Saginaw Asphalt

BACKGROUND/SUMMARY OF PROPOSED ACTION:

Additional supply of CP6 cold patching materials for temporary repair of sewer and water repairs needed to finish out year

FINANCIAL IMPLICATIONS: None

BUDGETED EXPENDITURE? YESX  NO  IF NO, PLEASE EXPLAIN:

Table with 5 columns: Dept., Name of Account, Account Number, Grant Code, Amount. Rows include 2496 Asphalt-Outside (6,150.00), 2493 Asphalt-Outside (850.00), 2493 Supplies (4,000.00), and a total row for FY20/21 GRAND TOTAL (11,000.00).

PRE-ENCUMBERED? YES  NO  REQUISITION NO: 21-0004546

ACCOUNTING APPROVAL: \_\_\_\_\_ Date: \_\_\_\_\_



## CITY OF FLINT

**WILL YOUR DEPARTMENT NEED A CONTRACT?** YES  NO   
*(If yes, please indicate how many years for the contract)* YEARS

**WHEN APPLICABLE, IF MORE THAN ONE (1) YEAR, PLEASE ESTIMATE TOTAL AMOUNT FOR EACH BUDGET YEAR: (This will depend on the term of the bid proposal)**

**BUDGET YEAR 1**

**BUDGET YEAR 2**

**BUDGET YEAR 3**

**OTHER IMPLICATIONS (i.e., collective bargaining):**

**STAFF RECOMMENDATION: (PLEASE SELECT):**  **APPROVED**  **NOT APPROVED**

**DEPARTMENT HEAD SIGNATURE:**

*Paul Simpson*

Paul Simpson, Water Distribution Supervisor

CITY OF FLINT



PROPOSAL#21000514

RESOLUTION NO: **200375**  
PRESENTED: **SEP 14 2020**  
ADOPTED: **SEP 14 2020**

BY THE CITY ADMINISTRATOR:

**RESOLUTION TO ACE SAGINAW PAVING COMPANY FOR ASPHALT PAVING MATERIALS**

On June 10, 2019, the Proper City Officials approved to issue a purchase order to Ace Saginaw Asphalt, 115 S. Averill Ave., Flint, Michigan 48506, for Asphalt Paving Materials (Resolution #190221) in the amount of \$424,400.00 for the first of a two-year proposal.

Ace Saginaw Paving was the responsive bidder out of four solicitations. On July 21, 2020, an emergency purchase order (#20-002593) was issued in the amount of \$74,000.00 for asphalt paving materials to repair hazardous conditions in the roadway.

The Department of Public Work has requested the second year of asphalt paving materials through June 30, 2021 in the amount of \$283,788.00.

Funding for said services are available in the budget for FY21 (07.01/20 - 06.30.21):

Account Number	Account Name	Amount
202-449.201-782.000	Asphalt - Major	\$ 95,000.00
203-449.201-782.000	Asphalt - Locals	\$142,500.00
202-449.203-782.000	Asphalt - Major Winter	\$ 13,400.00
203-449.203-782.000	Asphalt - Local Winter	\$ 12,155.00
202-449.211-782.000	Asphalt - Water Major	\$ 8,829.00
203-449.211-782.000	Asphalt - Water Locals	\$ 11,904.00
<b>FY21 (07/01/20 - 06/30/21) Total</b>		<b>\$ 283,788.00</b>

IT IS RESOLVED, that the Proper City Officials, are hereby authorized to do all things necessary to enter into a contract with Ace Saginaw Asphalt for Asphalt Paving Materials for FY21 (07/01/20 - 06/30/21) in the amount of \$283,788.00 and for an aggregate total of \$782,188.00.

APPROVED AS TO FORM:

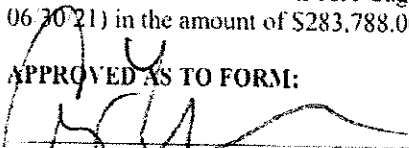
  
Angela Wheeler, Chief Legal Officer

FOR THE CITY OF FLINT:

  
Clyde Edwards, City Administrator

APPROVED AS TO FINANCE:

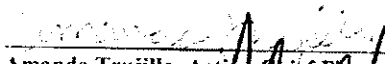
  
Amanda Trujillo, Acting Chief Financial Officer

APPROVED BY CITY COUNCIL:

  
Monica Galloway, City Council President

APPROVED AS TO PURCHASING:

  
Joyce A. McClane, Purchasing Manager



CITY OF FLINT

RESOLUTION STAFF REVIEW FORM

TODAY'S DATE: 08/26/20 (NEW SR ADDED WITH NEW TOTALS)

BID/PROPOSAL#

AGENDA ITEM TITLE: Ace Saginaw Paving Co. - Asphalt Material for FY21

PREPARED BY Betty Wideman - Transportation Street Maintenance (Please type name and Department)

VENDOR NAME: Ace Saginaw Paving Co

BACKGROUND/SUMMARY OF PROPOSED ACTION:

For asphalt material to repair hazardous conditions in the roadway, i.e. potholes, road cuts, water cuts

FINANCIAL IMPLICATIONS: None

BUDGETED EXPENDITURE? YES [X] NO [ ] IF NO, PLEASE EXPLAIN:

Table with 5 columns: Dept., Name of Account, Account Number, Grant Code, Amount. Rows include Streets Asphalt with various account numbers and amounts, ending with a total of \$283,788.00.

PRE-ENCUMBERED? YES [X] NO [ ] REQUISITION NO: 200003446 (Budgeted)

ACCOUNTING APPROVAL: \_\_\_\_\_ Date: \_\_\_\_\_

190221

(Proposal No. 20000514)

SUBMISSION NO.: \_\_\_\_\_

PRESENTED: 6-10-2019

ADOPTED: 6-10-2019

BY THE CITY ADMINISTRATOR:

**RESOLUTION TO ACE-SAGINAW PAVING CO. FOR ASPHALT PAVING MATERIALS**

**RESOLUTION**

The Department of Purchases and Supplies has solicited a proposal for asphalt paving materials as requested by various departments; and

Ace-Saginaw Paving Co., 115 S Averill Ave., Flint, MI was the sole bidder from four solicitations for said requirements. The funding for this request will come from the following account numbers: 202-449.201-782.000 (\$55,000.00), 202-449.203-782.000 (\$16,500.00), 202-449.211-782.000 (\$11,400.00), 203-449.201-782.000 (\$255,000.00), 203-449.203-782.000 (\$10,500.00), 203-449.211-782.000 (\$16,000.00), 590-540.208-782.000 (\$25,000.00), 591-540.202-782.000 (\$35,000.00); and

IT IS RESOLVED, Department of Purchases and Supplies is to issue purchase orders to Ace-Saginaw Paving Co for asphalt paving materials in an amount not to exceed \$424,400.00. (Major Street Fund, Local Street Fund, Sewer Fund, Water Fund) pending adoption of the FY20 budget

APPROVED PURCHASING DEPT.:

  
Joyca A. McClane  
Purchasing Manager

APPROVED AS TO FINANCE

  
Tamar A. Lewis  
Deputy Finance Director

APPROVED AS TO FORM

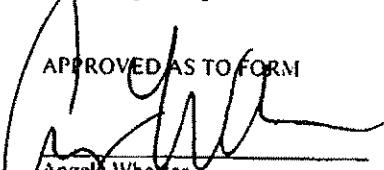
  
Angela Wheeler  
Chief Legal Officer

  
Steve Branch, City Administrator

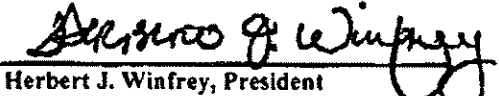
  
Herbert J. Winfrey, President  
City Council



## RESOLUTION STAFF REVIEW

**DATE:** May 23, 2019

**Agenda Item Title:** Purchase of asphalt materials from Ace Asphalt for paving and patching of city streets.

**Prepared By:** Betty Wideman

**Background/Summary of Proposed Action:** The purchase of asphalt materials for FY20 is necessary to begin paving, continue pothole patching and permanently repairing water cuts.

**Financial Implications:** None

**Budgeted Expenditure?** Yes  No  Please explain if no:

Account No.: 202-449.201-782.000 - \$55,000; 202-449.203-782.000 - \$16,500;  
202-449.211-782.000 - \$11,400; 203-449.201-782.000 - \$255,000; 203-449.203-  
782.000 - \$10,500; and 203-449.211-782.000 - \$16,000  
590-540,208-782,000, 591-540,202-782,000

**Pre-encumbered?** Yes  No  Requisition # 19-0001727, 19-1580 *mm*

**Other Implications (i.e., collective bargaining):**

Without this purchase order the Street Maintenance Division will not be able continue patching, paving or permanently repair water cuts for FY20.

**Staff Recommendation:** Recommend Approval

Staff Person: Betty J. Wideman  
Betty Wideman



SEALED PROPOSALS RECEIVED IN THE DIVISION OF PURCHASES & SUPPLIES  
 For Asphalt Paving Materials  
 PROPOSAL #21000514

Company: **Ace Saginaw Paving Co. – Flint, Michigan**

Approximate Annual Quantities – Not Guaranteed  
 Furnish as requested for the period 7/1/20 – 6/30/22

Item #	Description	Unit Price	Extended Total
1	2,000 Tons - 1100T, 20AA - New	\$ 63.25 /ton	\$126,500.00
2	4,000 Tons - High Stability Top, 20AA - New	\$ 65.00 /ton	\$260,000.00
3	200 Gallons – New LTBC-2 Trackless tack	\$ 5.20 /ton	\$1,040.00
4	2,000 Tons - Cold Milling Asphalt	\$ 8.00 /ton	\$16,000.00
5	16,600 Tons - Credit for Stripped Material returned for recycling	\$ N/A /ton	\$ N/A
6	Standard Performance Cold Patch	\$ N/A /ton	\$ N/A
7	Permanent High Performance Cold patch (meeting or exceeding the attached specifications)	\$ 118.00 /ton	\$ N/A
<p>"Permanent High Performance Cold Patch with a Performance Guarantee". Proposed material must provide a written guarantee to adhere permanently to the repaired street area for the life of the repair or actual volumes used will be replaced at no charge. Written copy of said guarantee must be provided with proposal response. Cold patch material must allow for immediate traffic use after application without any mixing, heating, or tracking required. Proposed material must be guaranteed to adhere to concrete, steel and asphalt under all types of weather conditions. Material must remain pliable at temperatures from -15 F to +105 F.</p>			
<b>Daily rent rate for equipment only:</b>			
8	Rental per day/hour large 8 to 12 ton roller		\$121.00
9	Rental per day/hour 46.5 ton flowboy with operator		\$150.00
10	Rate per day/hour paver with operator		\$210.00
11	Rental per day/hour double train to dump in with operator		\$146.00
<b>TOTALS</b>			\$ N/A

Only the specifier has the responsibility and judgment for determining whether a proposed substitution is an "or equal or exceeding" specification. Mfg., model #, and supporting documentation of specifications for alternates must be provided.





## CITY OF FLINT

---

**WILL YOUR DEPARTMENT NEED A CONTRACT?** YES  NO   
*(If yes, please indicate how many years for the contract)* YEARS

**WHEN APPLICABLE, IF MORE THAN ONE (1) YEAR, PLEASE ESTIMATE TOTAL AMOUNT FOR EACH BUDGET YEAR: (This will depend on the term of the bid proposal)**

**BUDGET YEAR 1**

**BUDGET YEAR 2**

**BUDGET YEAR 3**

**OTHER IMPLICATIONS (i.e., collective bargaining):**

**STAFF RECOMMENDATION: (PLEASE SELECT):** X  APPROVED  NOT APPROVED

**DEPARTMENT HEAD SIGNATURE:** Robert Bincsik  
Robert Bincsik, Director of Public Works



RESOLUTION NO.: 210259

PRESENTED: JUN - 6 2021

ADOPTED: \_\_\_\_\_

BID # 20-002

BY THE CITY ADMINISTRATOR:

**RESOLUTION TO ALDRIDGE TRUCKING INC. FOR ADDITIONAL FILL SAND**

WHEREAS, the Water Service Center (WCS) uses fill sand and stone for their repair and maintenance work. WCS recommends to extend the contract with Aldridge Trucking for additional fill sand.

Account Number	Account Name	Amount
590-540.202-752.000	Supplies	\$4,000.00
591-540.208-752.000	Supplies	6,000.00
	<b>FY2021 GRAND TOTAL</b>	<b>\$10,000.00</b>

IT IS RESOLVED, that the appropriate City Officials are authorized to do all things necessary to extend the contract with Aldridge Trucking to provide additional filled sand for FY2021 for the amount of \$10,000.00 and a contract total amount of \$108,000.00 under the same terms and conditions.

**APPROVED AS TO FORM:**

Angela Wheeler  
Angela Wheeler (May 25, 2021 17:33 EDT)  
**Angela Wheeler, Chief Legal Officer**

**APPROVED AS TO FINANCE:**

Shelbi Frayer  
shelbi frayer (May 26, 2021 08:59 EDT)  
**Shelbi Frayer, Chief Financial Officer**

**FOR THE CITY OF FLINT:**

Clyde D Edwards  
CLYDE D EDWARDS (May 27, 2021 13:34 EDT)  
**Clyde Edwards, City Administrator**

**APPROVED BY CITY COUNCIL:**

\_\_\_\_\_  
**Kate Fields, City Council President**

**APPROVED AS TO PURCHASING:**

Jennifer Ryan  
Jennifer Ryan (May 28, 2021 15:50 EDT)  
**Jenn Ryan, Deputy Finance Director**





## CITY OF FLINT

---

**WILL YOUR DEPARTMENT NEED A CONTRACT? YES NO X**  
*(If yes, please indicate how many years for the contract)*

**WHEN APPLICABLE, IF MORE THAN ONE (1) YEAR, PLEASE ESTIMATE TOTAL AMOUNT FOR EACH BUDGET YEAR: (This will depend on the term of the bid proposal)**

**BUDGET YEAR 1**

**BUDGET YEAR 2**

**BUDGET YEAR 3**

**OTHER IMPLICATIONS (i.e., collective bargaining):**

**STAFF RECOMMENDATION: (PLEASE SELECT): X APPROVED  NOT APPROVED**

**DEPARTMENT HEAD SIGNATURE:**

*Paul Simpson*

---

Paul Simpson, Water Distribution Supervisor

CITY OF FLINT



BID #20000002

RESOLUTION NO: 200300.1

PRESENTED: AUG 10 2020

ADOPTED: 8-17-2020

BY THE CITY ADMINISTRATOR:

**RESOLUTION TO ALDRIDGE TRUCKING, INC FOR LIMESTONE, FILL SAND & TOPSOIL**

The Division of Purchases & Supplies solicited proposals for Limestone, Fill Sand and Topsoil as requested by the Department of Public Works Department.

Four (4) proposals were submitted. Aldridge Trucking, Inc., 5135 N. Gale Rd., Davison, Michigan 48423, was the responsive bidder.

Funding for said services are available in the budget for FY21 (07/01/20 - 06/30/21):

Account Number	Account Name	Amount
590-550.202-775.000	Fill Sand, Topsoil & Limestone (Aggregates)	\$10,000.00
591-540.202-726.000	Fill Sand & Stone	\$33,000.00
590-540.208-726.000	Fill Sand & Stone	\$22,000.00
203-449.201-726.000	Topsoil	\$ 5,000.00
203-449.201-726.000	23A Limestone	\$21,000.00
203-449.201-726.000	Fill Sand	\$ 3,500.00
202-449.203-726.000	3CS Sand	\$ 3,500.00
FY21 (07/01/20 - 06/30/21) Total		\$ 98,000.00

IT IS RESOLVED, that the proper City Officials are authorized to approve the issuance of a purchase order to Aldridge Trucking, Inc. for Limestone, Fill Sand, and Topsoil in the amount not to exceed \$98,000.00 for FY21 (07/01/20 - 06/30/21) and pending FY22 budget for the amount of \$98,000.00.

APPROVED AS TO FORM:

Angela Wheeler, Chief Legal Officer

APPROVED AS TO FINANCE:

Amanda Trujillo, Acting Chief Financial Officer

FOR THE CITY OF FLINT:

Clyde Edwards, City Administrator

APPROVED BY CITY COUNCIL:

Monica Galloway, City Council President

APPROVED AS TO PURCHASING:

Joyce M. McClane  
Purchasing Manager





# CITY OF FLINT

## DEPARTMENT OF PUBLIC WORKS

Dr. Karen W. Weaver  
Mayor

Robert Bincsik, Director  
Public Works & Utilities

June 17, 2019

**TO:** Joyce A. McClane  
Purchasing Manager

**FROM:** Robert Bincsik, Director  
Public Works & Utilities

RB

**SUBJECT:** RECOMMENDATION – AGGREGATES, BID #20-002.

I have carefully reviewed the bids received for aggregates. I am recommending a split award – 6AA, 23A limestone be awarded to Stoneco of Michigan in the amount of \$35,000 per year and all other aggregates be awarded to Aldridge Trucking in the amount not to exceed \$45,000 per year.

Please use requisition #190002193 to Stoneco of Michigan in the amount of \$35,000 per year. Please use requisition #190001593 to Aldridge Trucking in the amount of \$45,000 per year.

If you have any questions or concerns, feel free to give me a call at ext. 2801.

/krn

## RESOLUTION STAFF REVIEW

---

**DATE:** June 17, 2019

**Agenda Item Title:** Stoneco of Michigan

**Prepared By:** Kathryn Neumann for Robert Bincsik

**Background/Summary of Proposed Action:**

The City of Flint Water Service Center requests that a purchase order be issued to Stoneco of Michigan for 6AA, 23A and crushed concrete less than 1", which are used in countless applications from backfill, road restoration, landscaping to new construction applications.

**Financial Implications:** Funding is available in the accounts listed below.

**Budgeted Expenditure?** Yes  No  Please explain if no:

**Account No.:** 590-540.208-726.000 (\$14,000), 591-540.202-726.000 (\$21,000)

**Pre-encumbered?** Yes  No  Requisition # 190002193

**Other Implications (i.e., collective bargaining):** None

**Staff Recommendation:** Recommend Approval

**Staff Person:**   
Robert Bincsik, Director of Public Works

## RESOLUTION STAFF REVIEW

---

**DATE:** June 17, 2019

**Agenda Item Title:** Aldridge Trucking

**Prepared By:** Kathryn Neumann for Robert Bincsik

**Background/Summary of Proposed Action:**

The City of Flint Water Service Center requests that a purchase order be issued to Aldridge Trucking for sand and planting soil, which are used in countless applications from backfill, road restoration, landscaping to new construction applications.

**Financial Implications:** Funding is available in the accounts listed below.

**Budgeted Expenditure?** Yes  No  Please explain if no:

**Account No.:** 590-540.208-726.000 (\$18,000), 591-540.202-726.000 (\$27,000)

**Pre-encumbered?** Yes  No  Requisition # 190001593

**Other Implications (i.e., collective bargaining):** None

**Staff Recommendation:** Recommend Approval

**Staff Person:** Robert Bincsik  
Robert Bincsik, Director of Public Works



SEALED PROPOSALS RECEIVED IN THE DIVISION OF PURCHASES & SUPPLIES  
**For AGGREGATES (2 Years)**  
 PROPOSAL #20000002

Approximate Annual Quantities – Not Guaranteed  
 Furnish as requested for the period 7/1/19 – 6/30/21

***Bidder #1 – StoneCo of Michigan, Monroe, MI***

DESCRIPTION	UOM	QTY	UNIT COST Year 1	EXT COST Year 1	UNIT COST Year 2	EXT COST Year 2
Sand, fill (class II)	TN	10,000	No Bid	No Bid	No Bid	No Bid
Soil, planting	YD	3,500	No Bid	No Bid	No Bid	No Bid
Soil, top	YD	2,000	No Bid	No Bid	No Bid	No Bid
Stone, 6AA	YD	5,000	\$25.70	\$128,500	\$26.75	\$133,750
Stone, 6A natural	YD	300	No Bid	No Bid	No Bid	No Bid
Sand, mason	YD	1,000	No Bid	No Bid	No Bid	No Bid
Sand, 2NS	YD	500	No Bid	No Bid	No Bid	No Bid
Sand, 3CS	YD	300	No Bid	No Bid	No Bid	No Bid
23A Limestone	YD	100	\$21.05	\$ 2,105	\$21.90	\$ 2,190
Concrete, crushed (under 1" in size)	YD	1,000	\$16.25	\$ 16,250	\$16.85	\$ 16,850

**GRAND TOTAL \$299,645.00**

**Year 1: \$146,855.00**

**Year 2: \$152,790.00**



**Bidder #2 – Aldridge Trucking Co., Inc., Davison, MI**

<b>DESCRIPTION</b>	<b>UOM</b>	<b>QTY</b>	<b>UNIT COST Year 1</b>	<b>EXT COST Year 1</b>	<b>UNIT COST Year 2</b>	<b>EXT COST Year 2</b>
Sand, fill (class II)	TN	10,000	\$ 7.00	\$ 70,000	\$ 7.50	\$ 75,000
Soil, planting	YD	3,500	\$13.50	\$ 47,250	\$14.00	\$ 49,000
Soil, top	YD	2,000	\$13.50	\$ 27,000	\$14.00	\$ 28,000
Stone, 6AA	YD	5,000	\$30.00	\$150,000	\$32.00	\$160,000
Stone, 6A natural	YD	300	\$23.00	\$ 6,900	\$25.00	\$ 7,500
Sand, mason	YD	1,000	\$16.00	\$ 16,000	\$17.00	\$ 17,000
Sand, 2NS	YD	500	\$15.00	\$ 7,500	\$16.00	\$ 8,000
Sand, 3CS	YD	300	\$15.00	\$ 4,500	\$16.00	\$ 4,800
23A Limestone	YD	100	\$25.00	\$ 2,500	\$26.50	\$ 2,650
Concrete, crushed (under 1" in size)	YD	1,000	\$18.50	\$ 18,500	\$19.50	\$ 19,500

**GRAND TOTAL \$721,600.00**

**Year 1: \$350,150.00**

**Year 2: \$371,450.00**



**Bidder #3 – Fuoss Gravel Company, Owosso, MI**

DESCRIPTION	UOM	QTY	UNIT COST Year 1	EXT COST Year 1	UNIT COST Year 2	EXT COST Year 2
Sand, fill (class II)	TN	10,000	-	-	-	-
Soil, planting	YD	3,500	-	-	-	-
Soil, top	YD	2,000	\$18.00	\$36,000	\$18.00	\$36,000
Stone, 6AA	YD	5,000	-	-	-	-
Stone, 6A natural	YD	300	-	-	-	-
Sand, mason	YD	1,000	\$15.00	\$15,000	\$15.00	\$15,000
Sand, 2NS	YD	500	-	-	-	-
Sand, 3CS	YD	300	-	-	-	-
23A Limestone	YD	100	-	-	-	-
Concrete, crushed (under 1" in size)	YD	1,000	-	-	-	-

**GRAND TOTAL \$102,000.00**

**Year 1: \$ 51,000.00**

**Year 2: \$ 51,000.00**



**Bidder #4 – Pierce and Pitt Trucking, Inc., Imlay City, MI**

<b>DESCRIPTION</b>	<b>UOM</b>	<b>QTY</b>	<b>UNIT COST Year 1</b>	<b>EXT COST Year 1</b>	<b>UNIT COST Year 2</b>	<b>EXT COST Year 2</b>
Sand, fill (class II)	TN	10,000	\$ 8.65	\$ 86,500	\$ 9.00	\$ 90,000
Soil, planting	YD	3,500	\$13.75	\$ 48,125	\$14.00	\$ 49,000
Soil, top	YD	2,000	\$13.75	\$ 27,500	\$14.00	\$ 28,000
Stone, 6AA	YD	5,000	\$28.00	\$140,000	\$29.75	\$148,750
Stone, 6A natural	YD	300	\$21.00	\$ 6,300	\$22.00	\$ 6,600
Sand, mason	YD	1,000	\$16.50	\$ 16,500	\$17.50	\$ 17,500
Sand, 2NS	YD	500	\$15.25	\$ 7,625	\$15.25	\$ 7,625
Sand, 3CS	YD	300	\$15.25	\$ 4,575	\$15.25	\$ 4,575
23A Limestone	YD	100	\$25.00	\$ 2,500	\$26.25	\$ 2,625
Concrete, crushed (under 1" in size)	YD	1,000	\$20.00	\$ 20,000	\$21.00	\$ 21,000

**GRAND TOTAL \$735,300.00**

**Year 1: \$359,625.00**

**Year 2: \$375,675.00**



**CITY OF FLINT**

**RESOLUTION STAFF REVIEW FORM**

**TODAY'S DATE:** 07/13/2020

**BID/PROPOSAL#** 20000002

**AGENDA ITEM TITLE:** WPC Aggregates

**PREPARED BY** Krystal Wallace

**VENDOR NAME:** Aldridge Trucking

**BACKGROUND/SUMMARY OF PROPOSED ACTION:**

WPC uses aggregate for various applications such as backfilling, road restorations, landscaping, new construction, and related projects. This purchase order allows WPC to complete some preventative maintenance tasks as well as maintain the grounds at the wastewater treatment facilities.

I recommend that the lowest qualified bidder, Aldridge Trucking, Inc., be awarded the bid in the amount of \$10,000.00. WPC spent \$13,000.00 for aggregates with Aldridge Trucking for FY 2020 and is requesting approval for a FY 21 purchase order in the amount of \$10,000.00.

Please issue a purchase order in the FY2021 budgeted amount of \$10,000.00, using funds from account 590-550.202-775.000.

**FINANCIAL IMPLICATIONS:** None

**BUDGETED EXPENDITURE?** YES  NO  IF NO, PLEASE EXPLAIN:

Dept.	Name of Account	Account Number	Grant Code	Amount
DPW-WPC	Repair/Maint Supplies	590-550.202-775.000		\$10,000.00
		<b>FY20/21 GRAND TOTAL</b>		<b>\$10,000.00</b>
	<b>TWO YEAR TOTAL (Includes FY 2020 expenses)</b>			<b>\$23,000.00</b>

**PRE-ENCUMBERED?** YES  NO  **REQUISITION NO:** 200002965

**ACCOUNTING APPROVAL:** \_\_\_\_\_ **Date:** \_\_\_\_\_

**WILL YOUR DEPARTMENT NEED A CONTRACT?** YES  NO





## CITY OF FLINT

*(If yes, please indicate how many years for the contract)* 2 YEARS

**WHEN APPLICABLE, IF MORE THAN ONE (1) YEAR, PLEASE ESTIMATE TOTAL AMOUNT FOR EACH BUDGET YEAR: (This will depend on the term of the bid proposal)**

**BUDGET YEAR 1** \$13,000.00 spent FY2020

**BUDGET YEAR 2** \$10,000.00 for FY2021

**BUDGET YEAR 3**

**OTHER IMPLICATIONS (i.e., collective bargaining):** None.

**STAFF RECOMMENDATION: (PLEASE SELECT):**  **APPROVED**  **NOT APPROVED**

**DEPARTMENT HEAD SIGNATURE:**

  
(Jeanette Best, WPC Manager)





## CITY OF FLINT

---

**WILL YOUR DEPARTMENT NEED A CONTRACT?** YES  NO   
*(If yes, please indicate how many years for the contract)* YEARS

**WHEN APPLICABLE, IF MORE THAN ONE (1) YEAR, PLEASE ESTIMATE TOTAL AMOUNT FOR EACH BUDGET YEAR: (This will depend on the term of the bid proposal)**

**BUDGET YEAR 1**

**BUDGET YEAR 2**

**BUDGET YEAR 3**

**OTHER IMPLICATIONS (i.e., collective bargaining):**

**STAFF RECOMMENDATION: (PLEASE SELECT):** X  **APPROVED**  **NOT APPROVED**

**DEPARTMENT HEAD SIGNATURE:** Robert Bincsik  
Robert Bincsik, Director of Public Works



CITY OF FLINT

RESOLUTION STAFF REVIEW FORM

TODAY'S DATE: 07/08/2020

BID/PROPOSAL#

AGENDA ITEM TITLE: Aggregates – Topsoil, Fill sand, 23A Limestone and 3CS sand

PREPARED BY Betty Wideman
(Please type name and Department)

VENDOR NAME: Aldridge Trucking

BACKGROUND/SUMMARY OF PROPOSED ACTION:

Aggregates for road repairs, yard repairs, sidewalks and other construction activities

FINANCIAL IMPLICATIONS: None

BUDGETED EXPENDITURE? YES [X] NO [ ] IF NO, PLEASE EXPLAIN:

Table with 5 columns: Dept., Name of Account, Account Number, Grant Code, Amount. Rows include Streets, Supplies - Topsoil, Supplies - 23A Limestone, Supplies - Fill Sand, Supplies - 3CS sand, and a total row for FY21 GRAND TOTAL \$33,000.00.

PRE-ENCUMBERED? YES [X] NO [ ] REQUISITION NO: 200003563, 3564, 3565, and 3566

ACCOUNTING APPROVAL: \_\_\_\_\_ Date: \_\_\_\_\_



## CITY OF FLINT

---

**WILL YOUR DEPARTMENT NEED A CONTRACT?** YES  NO   
*(If yes, please indicate how many years for the contract)* YEARS

**WHEN APPLICABLE, IF MORE THAN ONE (1) YEAR, PLEASE ESTIMATE TOTAL AMOUNT FOR EACH BUDGET YEAR: (This will depend on the term of the bid proposal)**

**BUDGET YEAR 1**

**BUDGET YEAR 2**

**BUDGET YEAR 3**

**OTHER IMPLICATIONS (I.e., collective bargaining):** None

**STAFF RECOMMENDATION: (PLEASE SELECT):**  **APPROVED**  **NOT APPROVED**

**DEPARTMENT HEAD SIGNATURE:** \_\_\_\_\_ Betty Wideman, Transportation Operations Manager (John Daly is aware of this request)

(

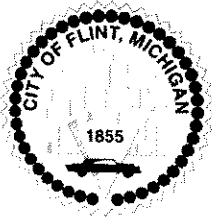

RESOLUTION NO.: 210260  
 PRESENTED: JUN - 6 2021  
 ADOPTED: \_\_\_\_\_

BY THE CITY ADMINISTRATOR:

**RESOLUTION TO PVS NOLWOOD CHEMICAL INC FOR LIQUID FERROUS**

WHEREAS, the Water Pollution Control (WPC) facility operates a Phosphate removal process as mandated by the National Pollution Discharge Elimination System (NPDES) permit. Aqueous Ferrous Chloride is used to remove Phosphate in the effluent discharge to the Flint River. WPC recommended the purchase of liquid ferrous for FY2021 and FY2022 to the only responsive bidder PVS Nolwood Chemical Inc at \$0.59/lb for an annual total of \$120,000.

Account Number	Account Name	Amount
590-550.100-753.000	Treatment Chemicals	\$120,000.000
	<b>FY2022 GRAND TOTAL</b>	<b>\$120,000.00</b>

IT IS RESOLVED, that the appropriate City Officials are authorized to do all things necessary to enter into the second year of the contract with PVS Nolwood Chemical Inc to provide liquid ferrous for FY2022, pending the adoption of the budget, for the amount of \$120,000.00.

**APPROVED AS TO FORM:**

Angela Wheeler  
Angela Wheeler (May 24, 2021 16:33 EDT)  
**Angela Wheeler, Chief Legal Officer**

**APPROVED AS TO FINANCE:**

Shelbi Frayer  
shelbi frayer (May 26, 2021 09:09 EDT)  
**Shelbi Frayer, Chief Financial Officer**

**FOR THE CITY OF FLINT:**

Clyde D. Edwards  
Clyde D. Edwards (May 27, 2021 13:13 EDT)  
**Clyde Edwards, City Administrator**

**APPROVED BY CITY COUNCIL:**

\_\_\_\_\_  
**Kate Fields, City Council President**

**APPROVED AS TO PURCHASING:**

Jennifer Ryan  
Jennifer Ryan (May 24, 2021 16:28 EDT)  
**Jenn Ryan, Deputy Finance Director**

REQ # 20-2924

CITY OF FLINT



PROPOSAL #21000504

RESOLUTION NO: 200249

PRESENTED: JUN 22 2020

ADOPTED: 6-24-2020

BY THE CITY ADMINISTRATOR:

RESOLUTION TO PVS NOLWOOD CHEMICAL INC FOR LIQUID FERROUS

The Division of Purchases & Supplies solicited proposals for Liquid Ferrous for fiscal year periods beginning 07/01/20 and ending 6/30/22 as requested by the Department of Public Works & Utilities.

PVS Nolwood Chemical Inc, Detroit, Michigan, was the only responsive bidder for said requirements. Funding for said services will come from the following account:

Dept.	Name of Account	Account #	Grant #	Amount
DPW)	Chemicals	590-550.100-740.500	N/A	\$120,000.00

IT IS RESOLVED, that the proper city officials, approve PVS Nolwood Chemical Inc. for Liquid Ferrous two (2) fiscal year periods beginning 07/01/20 and ending 6/30/22, for FY20/21 annual amount not to exceed \$120,000.00.

APPROVED AS TO PURCHASING:

Joyce A. McClane  
Purchasing Manager

APPROVED AS TO FINANCE:

Amanda Trujillo  
Acting Chief Financial Officer

APPROVED AS TO FORM:

Angela Wheeler, Chief Legal Officer

Clyde Edwards, City Administrator

CITY COUNCIL:

Monica Galloway, Council President



CITY OF FLINT

RESOLUTION STAFF REVIEW FORM

TODAY'S DATE: 06/01/2020

BID/PROPOSAL# P21-504

AGENDA ITEM TITLE: Liquid Ferrous

PREPARED BY Don Lewis (DPW)
(Please type name and Department)

VENDOR NAME: PVS Nolwood Chemical Inc.

BACKGROUND/SUMMARY OF PROPOSED ACTION:

The Water Pollution Control Facility operates a Phosphate removal process as mandated by its National Pollution Discharge Elimination System permit (NPDES). Aqueous Ferrous Chloride is used to remove Phosphate in the effluent discharge to the Flint River.

FINANCIAL IMPLICATIONS: NA

BUDGETED EXPENDITURE? YES [X] NO [ ] IF NO, PLEASE EXPLAIN:

Table with 5 columns: Dept., Name of Account, Account Number, Grant Code, Amount. Row 1: DPW, PVS Nolwood Chemical Inc., 590-550.100-740.500, \$120,000.00 (\$0.59 per lb.). Row 2: FY19/20 GRAND TOTAL

PRE-ENCUMBERED? YES [X] NO [ ] REQUISITION NO: 200002924

ACCOUNTING APPROVAL: \_\_\_\_\_ Date: \_\_\_\_\_

WILL YOUR DEPARTMENT NEED A CONTRACT? YES [ ] NO [X]





# CITY OF FLINT

*(If yes, please indicate how many years for the contract)* \_\_\_\_\_ YEARS

**WHEN APPLICABLE, IF MORE THAN ONE (1) YEAR, PLEASE ESTIMATE TOTAL AMOUNT FOR EACH BUDGET YEAR: *(This will depend on the term of the bid proposal)***

**BUDGET YEAR 1** \$120,000.00

**BUDGET YEAR 2** \$126,000.00

**BUDGET YEAR 3**

**OTHER IMPLICATIONS *(i.e., collective bargaining)*:** NA

**STAFF RECOMMENDATION: *(PLEASE SELECT)*:**  **APPROVED**  **NOT APPROVED**

**DEPARTMENT HEAD SIGNATURE:** Jeanette H. Best WPC Manager  
*(PLEASE TYPE NAME, TITLE)*



# CITY OF FLINT

## Department of Purchases & Supplies

Sheldon A. Neeley  
Mayor

May 22, 2020

**TO:** Krystal Wallace  
Jeanette Best  
John Florshinger

**FROM:** Joyce A. McClane  
Purchasing Manager

**SUBJECT:** SEALED BIDS

Attached is one (1) sealed bid that was received for **PROPOSAL #21000504- WPC-AQUEOUS FERROUS CHLORINE**. Enclosed are copies for your file. **Bid Due Date: 5/06/20. Enclosed is a spreadsheet.**

Your staff review and recommendation form is needed as soon as possible. Please use the new fillable form. This form is to be used for your staff review.

A staff review must be completed for **ALL Bids/Proposals**. Please let me know if you need a copy of the fillable form.

This project has been identified that multiple departments use this item. Please get with those departments to determine the total usage and the amount that needs to go to Council for approval. This proposal is good for 2 years.

**Please note:** If your project is being funded by any grants issued by the federal government, you must go to: <https://www.dol.gov/ofccp/regs/compliance/preaward/debarlst.htm> to ensure that the selected vendor has not been debarred.

**PLEASE NOTE:**

Results may be viewed next business day online **EXCEPT** when a bid is under review. The bidders/public will only see the names of the bidders that submitted a bid, not their cost. This will protect the bidders cost in case there is a re-bid.



Joyce A. McClane

CITY OF FLINT  
DEPARTMENT OF FINANCE  
Division of Purchases Supplies

BID DUE DATE:  
05/06/20

**P21-504 - AQUEOUS FERROUS CHLORINE @ WATER POLLUTION CONTROL**

**TWO (2) YEARS**

<b>COMPANY</b>	PVS Chemicals	
<b>RATE PER POUND</b>	\$	0.59
<b>POINT OF SHIPMENT</b>	Detroit, MI	
<b>CARRIER</b> (See other details)	PVS Transportation	
<b>CITY, STATE</b>	Detroit, MI	

*Bids must be reviewed and evaluated before award*

**CITY OF FLINT, MICHIGAN  
FINANCE DEPARTMENT  
DIVISION OF PURCHASES & SUPPLIES**



Sheldon A. Neeley, Mayor

**CITY OF FLINT PROPOSAL NO. 21000504**

**AQUEOUS FERROUS CHLORINE @  
WATER POLLUTION CONTROL**

Date Posted: 04/19/20

**CITY OF FLINT PROPOSAL NO.21000504**

**SUPPLY AQUEOUS FERROUS CHLORINE @  
WATER POLLUTION CONTROL**

On Tuesday, March 10, 2020, Governor Gretchen Whitmer declared a State of Emergency after two individuals were confirmed testing presumptively positive for COVID-19. On Thursday, March 12, 2020, Mayor Sheldon A. Neeley declared a local State of Emergency to exist in the City of Flint as a result of the threat of COVID-19. On Sunday, March 15, 2020, effective March 17, 2020, Mayor Neeley, based on the COVID-19 public health threat, closed City Hall to the public. Residents were asked to take precautionary measures. On March 22, 2020, Mayor Neeley asked residents to participate in a voluntary shelter in place. On March 23, 2020, the City Council approved the continuation of the declaration of a State of Emergency.

Based on the White House guidelines issued on March 16, 2020, and continued on March 30, 2020, for an additional 30 days, it is recommended that people not gather in groups larger than 10 people in order to "flatten" the curve and slow the spread of the virus. On March 24, 2020, Governor Whitmer instituted Executive Order 2020-21, a temporary requirement to suspend activities that are not necessary to sustain or protect life, prohibiting "in-person" work with exceptions for essential and critical infrastructure workers.

**FOR THE TIME BEING,  
BIDS WILL ONLY BE ACCEPTED BY MAIL**

Please note: All detailed bids received after 1:00 PM (EST) of the due date will not be considered. Bids must be in a sealed envelope clearly identifying the proposal title and number. Faxed bids are not accepted.

**THIS PAGE INTENTIONALLY LEFT BLANK**

**CITY OF FLINT**  
**DEPARTMENT OF FINANCE**  
**DIVISION OF PURCHASES AND SUPPLIES**  
City Hall, 1101 S. Saginaw Street, Room #203 – Flint, Michigan 48502  
(810) 766-7340 [www.cityofflint.com](http://www.cityofflint.com)

**INVITATION TO BID**

**OWNER/RETURN TO:**

THE CITY OF FLINT  
FINANCE DEPARTMENT – DIVISION OF PURCHASES AND SUPPLIES  
1101 S. SAGINAW ST., ROOM 203, 2nd FLOOR  
FLINT, MI 48502

**PROPOSAL NO: 21000504**

**SCOPE OF WORK:**

The City of Flint, Finance Department of Purchases & Supplies, is soliciting sealed bids for providing:

**SUPPLY AQUEOUS FERROUS CHLORIDE @ WATER POLLUTION CONTROL**

Per the attached additional requirements.

If your firm is interested in providing the requested services, please submit one (1) original and one (1) printed copy of your detailed bid to the City of Flint, Finance Department of Purchases and Supplies, 1101 S. Saginaw St., Room 203, Flint, MI, 48502, by **May 6, 2020 at 1:00 PM (EST)**. Please note: all detailed bids received after 1:00 PM (EST) will not be considered. Bids must be in a sealed envelope clearly identifying the proposal and number. Faxed bids are not accepted.

The City reserves the right to waive any irregularities and accept or reject any or all proposals submitted. The City is an equal opportunity employer.

All additional proposal documents, requirements, addendums, specifications, and plans/drawings (if utilized) are available on the Purchasing page of the City of Flint's web site at <https://www.cityofflint.com/finance/purchasing/bids-2/> under "open bids" and the specific bid or proposal number assigned to this notice.

New vendors should complete and submit a vendor application, IRS W-9 Form, and ONLY a Vendor ACH Payment Authorization Form if awarded bid with the City of Flint. Links to these forms are available at <https://www.cityofflint.com/finance/accounts-payable-department/>

Results may be viewed next business day online EXCEPT when a bid is under review. The bidders/public will only see the names of the bidders that submitted a bid, not their cost. This will protect the bidders cost in case there is a re-bid. <https://www.cityofflint.com/finance/purchasing/results/> under "bid results".



## **INSTRUCTIONS TO VENDORS**

- 1) **PRE-BID INFORMATION AND QUESTIONS:** Each bid that is timely received will be evaluated on its merit and completeness of all requested information. In preparing bids, Bidders are advised to rely only upon the contents of this Request for Proposals (RFP) and accompanying documents and any written clarifications or addenda issued by the City of Flint. If a Bidder finds a discrepancy, error or omission in the RFP package, or requires any written addendum thereto, the Bidder is requested to notify the Purchasing contact noted on the cover of this RFP, so that written clarification may be sent to all prospective Bidders. **THE CITY OF FLINT IS NOT RESPONSIBLE FOR ANY ORAL INSTRUCTIONS.** All questions must be submitted in writing to the Finance Department of Purchases and Supplies before any pre-bid deadline (if specified) or at least one (1) week prior to the proposal opening date indicated on the front of this document.
  
- 2) **RFP MODIFICATIONS:** The City of Flint has the right to correct, modify or cancel the RFP, in whole or in part, or to reject any Bid, in whole or in part, within the discretion of the City of Flint, or their designee. If any such changes are made, all known recipients of the RFP will be sent a copy of such changes. If any changes are made to this RFP document by any party other than the City of Flint, the original document in the City of Flint's files takes precedence.
  
- 3) **PROPOSAL SUBMISSION:**
  - a) The Bidder must include the following items, or the proposal may be deemed non-responsive:
    - i) All forms contained in this RFP, fully completed.
  
  - b) Bids must be submitted to the Finance Department of Purchases and Supplies, City of Flint, 1101 S. Saginaw Street, Room 203, Flint, Michigan 48502 by the date and time indicated as the deadline. The Purchasing Department time stamp will determine the official receipt time. It is each Bidder's responsibility to insure that their proposal is time stamped by the Purchasing Department by the deadline. This responsibility rests entirely with the Bidder, regardless of delays resulting from postal handling or for any other reasons. Proposals will be accepted at any time during the normal course of business only, said hours being 8:00 a.m. to 5:00 p.m. local time, Monday through Friday, legal holidays as exception.
  
  - c) Bids must be enclosed in a sealed, non-transparent envelope, box or package, and clearly marked on the outside with the following: RFP Title, RFP Number, Deadline and Bidder's name.
  
  - d) Submission of a bid establishes a conclusive presumption that the Bidder is thoroughly familiar with the Request for Proposals (RFP), and that the Contractor understands and agrees to abide by each and all of the stipulations and requirements contained therein.
  
  - e) All prices and notations must be typed or printed in ink. No erasures are permitted. Mistakes may be crossed out and corrections must be initialed in ink by the person(s) signing the bid.
  
  - f) Proposals sent by email, facsimile, or other electronic means will not be considered unless specifically authorized in this RFP.

- g) All costs incurred in the preparation and presentation of the bid are the Bidder's sole responsibility; no pre-bid costs will be reimbursed to any Bidder. All documentation submitted with the proposal will become the property of the City of Flint.
  - h) Proposals must be held firm for a minimum of 120 days.
- 4) **EXCEPTIONS:** Bidder shall clearly identify any proposed deviations from the Terms or Scope in the Request for Proposals. Each exception must be clearly defined and referenced to the proper paragraph in this RFP. The exception shall include, at a minimum, the proposed substitute language and opinion as to why the suggested substitution will provide equivalent or better service and performance. If no exceptions are noted in the bid, the City of Flint will assume complete conformance with this specification and the successful Bidder will be required to perform accordingly. Bids not meeting all requirements may be rejected.
  - 5) **DUPLICATE BIDS:** No more than one (1) bid from any Bidder including its subsidiaries, affiliated companies and franchises will be considered by the City of Flint. In the event multiple proposals are submitted in violation of this provision, the City will have the right to determine which bid will be considered or, at its sole option, reject all such multiple proposals.
  - 6) **WITHDRAWAL:** Bids may only be withdrawn by written notice prior to the date and time set for the opening of bids. No bid may be withdrawn after the deadline for submission.
  - 7) **REJECTION/GOOD STANDING:** The City of Flint reserves the right to reject any or all bids, or to accept or reject any bid in part, and to waive any minor informality or irregularity in bids received if it is determined by the City of Flint, or their designee, that the best interest of the City will be served by doing so. No bid will be considered from any person, firm or corporation in arrears or in default to the City on any contract, debt, taxes or other obligation, or if the Bidder is debarred by the City of Flint from consideration for a contract award pursuant to Section 18-21.5 (d) of Article IV of the "Purchasing Ordinance of the City of Flint".
  - 8) **PROCUREMENT POLICY:** Procurement for the City of Flint will be handled in a manner providing fair opportunity to all businesses. This will be accomplished without abrogation or sacrifice of quality and as determined to be in the best interest of the City. The City of Flint and their officials have the vested authority to execute a contract, subject to City Council and Mayoral approval where required.
  - 9) **BID SIGNATURES:** Bids must be signed by an authorized official of the Bidder Each signature represents binding commitment upon the Bidder to provide the goods and/or services offered to the City of Flint if the Bidder is determined to be the lowest Responsive and Responsible Bidder.
  - 10) **CONTRACT AWARD/SPLIT AWARDS:** The City of Flint reserves the right to award by item, group of items, or total bid. The Bidder to whom the award is made will be notified at the earliest possible date. Tentative acceptance of the bid, intent to recommend award of a contract and actual award of the contract will be provided by written notice sent to the Bidder at the address designated in the bid if a separate Agreement is required to be executed. After a final award of the Agreement by the City of Flint, the Contractor/Vendor must execute and perform said Agreement. All proposals must be firm for at least 120 days from the due date of the proposal. If, for any reason, a contract is not executed with the selected Bidder within 14 days

after notice of recommendation for award, then the City may recommend the next lowest responsive and responsible Bidder.

- 11) **NO RFP RESPONSE:** Bidders who receive this RFP but who do not submit a bid should return this RFP package stating "No Bid" and are encouraged to list the reason(s) for not responding. Failure to return this form may result in removal of the Bidder's name from all future lists.
- 12) **FREEDOM OF INFORMATION ACT (FOIA) REQUIREMENTS:** Bids are subject to public disclosure after the deadline for submission in accordance with state law.
- 13) **ARBITRATION:** Contractor agrees that for all claims, disputes, and other matters arising out of or relating to this agreement, Contractor must request the City's consent to arbitrate within 30 days from the date the Contractor knows or should have known the facts giving rise to the claim, dispute or question.
  - (a) Notice of a request for arbitration must be submitted in writing by certified mail or personal service upon the Chief Legal Officer.
  - (b) Within 60 days from the date a request for arbitration is received by the City, the City shall inform Contractor whether it agrees to arbitrate. If the City does not consent, Contractor may proceed with an action in a court of competent jurisdiction within the State of Michigan. If the City does consent, then within 30 days of the consent each party shall submit to the other the name of one person to serve as an arbitrator. The two arbitrators together shall then select a third person, the three together shall then serve as a panel in all proceedings. Any unanimous decision of the three arbitrators shall be a final binding decision. The City's failure to respond to a timely, conforming request for arbitration is deemed consent to arbitration.
  - (c) The costs of the arbitration shall be split and borne equally between the parties and such costs are not subject to shifting by the arbitrator.
  - (d) Contractor's failure to comply with any portion (including timeliness) of this provision shall be deemed a permanent waiver and forfeiture of the claim, dispute, or question.
  - (e) This provision shall survive the expiration or termination of this Agreement in perpetuity.
- 14) **BID HOLD:** The City of Flint may hold bids for a period of one hundred twenty (120) days from opening, for the purpose of reviewing the results and investigating the qualifications of bidders prior to making an award.
- 15) **NONCOMPLIANCE:** Failure to deliver in accordance with specifications will be cause for the City of Flint and they may cancel the contract or any part thereof and purchase on the open market, charging any additional cost to the Contractor/Vendor.
- 16) **DISCLAIMER OF CONTRACTUAL RELATIONSHIP:** Nothing contained in these documents shall create any contractual relationship between the City and any Subcontractor or Sub-subcontractor.
- 17) **ERRORS AND OMISSIONS:** Bidder is not permitted to take advantage of any obvious errors or omissions in specifications.

- 18) **INTERPRETATION:** In the event that any provision contained herein shall be determined by a court of competent jurisdiction or an appropriate administrative tribunal to be contrary to the provision of law or to be unenforceable for any reason, then, to the extent necessary and possible to render the remainder of this Agreement enforceable, such provision may be modified or severed by such court or administrative tribunal having jurisdiction over this Agreement and the interpretation thereof, or the parties hereto, so as to, as nearly as possible, carry out the intention of the parties hereto, considering the purpose of the entire Agreement in relation to such provision.
- 19) **LAWS AND ORDINANCES:** The Bidder shall obey and abide by all of the laws, rules and regulations of the Federal Government, State of Michigan, Genesee County and the City of Flint, applicable to the performance of this Agreement, including, but not limited to, labor laws, and laws regulating or applying to public improvement, local government, and its operational requirements.
- 20) **LOCAL PREFERENCE:** Contractors/bidders located within the corporate city limits of Flint, Michigan may be given a seven percent (7%) competitive price advantage. Additionally, if the lowest responsible bidder is not located within the limits of the City of Flint, but is located within the County of Genesee, and said bidder does not exceed the bid of the lowest non-local bidder by more than three and one-half percent (3-1/2%), then said lowest Genesee County bidder may be determined to be the lowest responsible bidder, and make the award to such Genesee County bidder accordingly, subject to the approval of the City Council. If the lowest non-local bidder does not exceed that of any Proposers/bidders by (7%) inside the City of Flint or (3-1/2%) inside the County of Genesee, then the Purchasing Director shall be allowed to request that the lowest local vendor match the price offered by the lowest non-local vendor.
- 21) **MATERIAL WORKMANSHIP AND STANDARDS OF PERFORMANCE:** The Bidder agrees to exercise independent judgment and to complete performance under this Agreement in accordance with sound professional practices. In entering into this Agreement, the City is relying upon the professional reputation, experience, certification and ability of the Bidder by her/him/themselves or by others employed by her/him/them and working under their direction and control. The continued effectiveness of this Agreement during its term or any renewal term shall be contingent, in part, upon the Bidder maintaining her/his/their operating qualifications in accordance with the requirements of federal, state and local laws. All materials furnished must be new, of latest model and standard first grade quality, or best workmanship and design, unless otherwise expressly specified. Bidder, if required, must furnish satisfactory evidence of quality materials; offers of experimental or unproven equipment may be disregarded.
- 22) **MODIFICATIONS/CHANGES:** Any modification to this agreement must be in writing and signed by the authorized employee, officer, board or council representative authorized to make such modifications pursuant to the State law and local ordinances.
- 23) **NON-COLLUSION:** The Bidder acknowledges that by signing this document that she/he/they is/are duly authorized to make said offer on behalf of the company she/he/they represent(s) and that said bid is genuine and not sham or collusive and not made in the interests or on behalf of any person not therein named, and that she/he/they and said bidder have not directly induced or solicited any other person(s) or corporation to refrain from responding to this solicitation and that she/he/they and said bidder have not in any manner sought by collusion to secure to themselves and said bidder any advantage over any other bidder.

24) **NON-DISCRIMINATION:** Pursuant to the requirements of 1976 P.A. 453 (Michigan Civil Rights Act) and 1976 P.A. 220 (Michigan Handicapped Rights Act), the local unit and its agent agree not to discriminate against any employee or applicant for employment with respect to hire, tenure, terms, conditions, or privileges of employment or a matter directly or indirectly related to employment because of race, color, religion, national origin, age, sex, height, weight, marital status or because of a handicap that is unrelated to the person's ability to perform the duties of nondiscrimination provision identical to this provision and binding upon any and all contractors and subcontractors. A breach of this covenant shall be regarded as a material breach of this contract.

25) **SUBCONTRACTING:** No subcontract work shall be started prior to the written approval of the subcontractor by the City. The City reserves the right to accept or reject any subcontractor.

26) **UNION COMPLIANCE:** Bidder agrees to comply with all regulations and requirements of any national or local union(s) that may have jurisdiction over any of the materials, facilities, services or personnel to be furnished by the City.

27) **WAIVER:** Failure of the City to insist upon strict compliance with any of the terms, covenants or conditions of this Agreement shall not be deemed a waiver of that term, covenant or condition or of any other term, covenant or condition. Any waiver or relinquishment of any right or power hereunder at any one or more times shall not be deemed a waiver or relinquishment of that right or power at any other time.

28) **CITY INCOME TAX WITHHOLDING:** Contractor and any subcontractor engaged in this contract shall withhold from each payment to his employees the City income tax on all of their compensation subject to tax, after giving effect to exemptions, as follows:

a) Residents of the City:

At a rate equal to 1% of all compensation paid to the employee who is a resident of the City of Flint.

b) Non-residents:

At a rate equal to 1/2% of the compensation paid to the employee for work done or services performed in the City of Flint.

These taxes shall be held in trust and paid over to the City of Flint in accordance with City ordinances and State law. Any failure to do so shall constitute a substantial and material breach of this contract.

29) **CONTRACT DOCUMENTS:** The invitation for proposal, instructions to proposal, proposal, affidavit, addenda (if any), statement of Bidder's qualifications (when required), general conditions, special conditions, performance bond, labor and material payment bond, insurance certificates, technical specifications, and drawings, together with this agreement, form the contract, and they are as fully a part of the contract as if attached hereto or repeated herein.

30) **DISCLAIMER OF CONTRACTUAL RELATIONSHIP WITH SUBCONTRACTORS:** Nothing contained in the Contract Documents shall create any contractual relationship between the City and any Subcontractor or Sub-subcontractor.

31) **EFFECTIVE DATE:** Any agreement between the City and the Bidder shall be effective upon the date that it is executed by all parties hereto.

- 32) **FORCE MAJEURE:** Neither party shall be responsible for damages or delays caused by Force Majeure nor other events beyond the control of the other party and which could not reasonably have anticipated the control of the other party and which could not reasonably have been anticipated or prevented. For purposes of this Agreement, Force Majeure includes, but is not limited to, adverse weather conditions, floods, epidemics, war, riot, strikes, lockouts, and other industrial disturbances; unknown site conditions, accidents, sabotage, fire, and acts of God. Should Force Majeure occur, the parties shall mutually agree on the terms and conditions upon which the services may continue.
- 33) **INDEMNIFICATION:** To the fullest extent permitted by law, Bidder agrees to defend, pay on behalf of, indemnify, and hold harmless the City of Flint, its elected and appointed officials, employees and volunteers and others working on behalf of the City of Flint, including the Project Manager, against any and all claims, demands, suits, or losses, including all costs connected therewith, and for any damages which may be asserted, claimed, or recovered against or from the City of Flint, its elected and appointed officials, employees, volunteers or others working on behalf of the City of Flint, by reason of personal injury, including bodily injury or death and/or property damage, including loss of use thereof, which may arise as a result of Bidder's acts, omissions, faults, and negligence or that of any of his employees, agents, and representatives in connection with the performance of this contract. Should the Bidder fail to indemnify the City in the above-mentioned circumstances, the City may exercise its option to deduct the cost that it incurs from the contract price forthwith. *These provisions shall survive the termination or expiration of any agreement entered into as a result of this request.*
- 34) **INDEPENDENT CONTRACTOR:** No provision of this contract shall be construed as creating an employer-employee relationship. It is hereby expressly understood and agreed that Bidder is an "independent contractor" as that phrase has been defined and interpreted by the courts of the State of Michigan and, as such, Bidder is not entitled to any benefits not otherwise specified herein.
- 35) **NO THIRD-PARTY BENEFICIARY:** No contractor, subcontractor, mechanic, material man, laborer, vendor, or other person dealing with the principal Contractor shall be, nor shall any of them be deemed to be, third-party beneficiaries of this contract, but each such person shall be deemed to have agreed (a) that they shall look to the principal Contractor as their sole source of recovery if not paid, and (b) except as otherwise agreed to by the principal Contractor and any such person in writing, they may not enter any claim or bring any such action against the City under any circumstances. Except as provided by law, or as otherwise agreed to in writing between the City and such person, each such person shall be deemed to have waived in writing all rights to seek redress from the City under any circumstances whatsoever.
- 36) **NON-ASSIGNABILITY:** Contractor shall not assign or transfer any interest in this contract without the prior written consent of the City provided, however, that claims for money due or to become due to Contractor from the City under this contract may be assigned to a bank, trust company, or other financial institution without such approval. Notice of any such assignment or transfer shall be furnished promptly to the City.
- 37) **NON-DISCLOSURE/CONFIDENTIALITY:** Contractor agrees that the documents identified herein as the contract documents are confidential information intended for the sole use of the City and that Contractor will not disclose any such information, or in any other way make such documents public, without the express written approval of the City or the order of the court of appropriate jurisdiction or as required by the laws of the State of Michigan.

- 38) **RECORDS PROPERTY OF CITY:** All documents, information, reports and the like prepared or generated by Contractor as a result of this contract shall become the sole property of the City of Flint.
- 39) **SEVERABILITY:** In the event that any provision contained herein shall be determined by a court or administrative tribunal to be contrary to a provision of state or federal law or to be unenforceable for any reason, then, to the extent necessary and possible to render the remainder of this Agreement enforceable, such provision may be modified or severed by such court or administrative tribunal so as to, as nearly as possible, carry out the intention of the parties hereto, considering the purpose of the entire Agreement in relation to such provision. The invalidation of one or more terms of this contract shall not affect the validity of the remaining terms.
- 40) **TERMINATION:** This contract may be terminated by either party hereto by submitting a notice of termination to the other party. Such notice shall be in writing and shall be effective 30 days from the date it is submitted unless otherwise agreed to by the parties hereto. Contractor, upon receiving such notice and prorated payment upon termination of this contract shall give to the City all pertinent records, data, and information created up to the date of termination to which the City, under the terms of this contract, is entitled.
- 41) **TIME PERFORMANCE:** Contractor's services shall commence immediately upon receipt of the notice to proceed and shall be carried out forthwith and without reasonable delay.
- 42) **EVALUATION OF PROPOSAL:** In the City's evaluation of proposals, at minimum: cost, serviceability, financial stability, and all requirements set forth in this document shall be considered as selection and award criteria unless otherwise specified.
- 43) **PREVAILING WAGE:** When applicable, all work for state and federal funded projects must meet Davis-Bacon Act requirements and full prevailing wage. Information on Davis-Bacon reporting and requirements, including payroll reporting, can be found at: <https://www.dol.gov/whd/govcontracts/dbra.htm>
- 44) **BONDS – PAYMENT AND PERFORMANCE:** The City of Flint may request that before any contract, exceeding \$50,000.00 for the construction, alteration, or repair of any public building or public work or improvement of the state or a county, city, village, township, school district, public educational institution, other political subdivision, public authority, or public agency hereinafter referred to as the "governmental unit", is awarded, the proposed contractor, hereinafter referred to as the "principal contractor", shall furnish at his or her own cost to the governmental unit a performance bond and a payment bond which shall become binding upon the award of the contract to the principal contractor. However, if the principal contractor is a common carrier as defined in section 3 of Act No. 300 of the Public Acts of 1909, as amended, being section 462.3 of the Michigan Compiled Laws, or the designated operator of a state subsidized railroad, the principal contractor may provide an irrevocable letter of credit from a state or national bank or a state or federally chartered savings and loan association instead of the bonds. Neither the invitation for bids, nor any person acting, or purporting to act, on behalf of the governmental unit shall require that the bonds be furnished by a particular bank or surety company, or through a particular agent or broker, or through a bank, company, agent, or broker in any particular locality.

**Payment Bond**

The payment bond shall be in a minimum amount of 25% of the contract amount solely for the protection of claimants, as defined in section 6, supplying labor or materials to the principal contractor or his subcontractors in the protection of the work provided for in the contract. Payment bond shall be set by the City of Flint and shall be agreed upon by parties of any contract.

**Performance Bond**

The performance bond shall be in a minimum amount of 25% of the contract amount, conditioned upon the faithful performance of the contract in accordance with the plans, specifications and terms thereof. The bond shall be solely for the protection of the governmental unit awarding the contract. Performance bond shall be set by the City of Flint and shall agree upon by parties of any contract.

45) **INSURANCE/WORKERS COMPENSATION:** Contractor shall not commence work under this contract until he has procured and provided evidence of the insurance required under this section. All coverage shall be obtained from insurance companies licensed and authorized to do business in the State of Michigan unless otherwise approved by the City's Risk Manager. Policies shall be reviewed by the City's Risk Manager for completeness and limits of coverage. All coverage shall be with insurance carriers acceptable to the City of Flint. Contractor shall maintain the following insurance coverage for the duration of the contract.

(a) Commercial General Liability coverage of not less than one million dollars (\$1,000,000) combined single limit with the City of Flint, and including all elected and appointed officials, all employees and volunteers, all boards, commissions and/or authorities and their board members, employees and volunteers, named as "Additional Insured." This coverage shall be written on an ISO occurrence basis form and shall include: Bodily Injury, Personal Injury, Property Damage, Contractual Liability, Products and Completed Operations, Independent Contractors; Broad Form Commercial General Liability Endorsement, (XCU) Exclusions deleted and a per contract aggregate coverage. This coverage shall be primary to the Additional Insured, and not contributing with any other insurance or similar protection available to the Additional Insured, whether said other available coverage be primary, contributing, or excess.

(b) Workers Compensation Insurance in accordance with Michigan statutory requirements, including Employers Liability coverage.

(c) Commercial Automobile Insurance in the amount of not less than \$1,000,000 combined single limit per accident with the City of Flint, and including all elected and appointed officials, all employees and volunteers, all boards, commissions and/or authorities and their board members, employees and volunteers, named as "Additional Insured." This coverage shall be written on ISO business auto forms covering Automobile Liability, code "any auto."



**(d) Professional Liability - Errors and Omissions.** All projects involving the use of Architects, civil engineers, landscape design specialists, and other professional services must provide the City of Flint with evidence of Professional Liability coverage in an amount not less than one million dollars (\$1,000,000) Evidence of this coverage must be provided for a minimum of three years after project completion. Any deductibles or self-insured retention must be declared to and approved by the City. In addition, the total dollar value of all claims paid out on the policy shall be declared. At the option of the City, either the insurer shall reduce or eliminate such deductibles or self-insured retention with respect to the City, its officials, employees, agents and volunteers; or Contractor shall procure a bond guaranteeing payment of losses and related investigation, claim, administration, and defense expenses.

Contractor shall furnish the City with one certificate of insurance for all coverage requested with original endorsements for those policies requiring the Additional Insured. PJI certificates of insurance must provide the City of Flint with not less than 30-days advance written notice in the event of cancellation, non-payment of premium, non-renewal, or any material change in policy coverage. In addition, the wording "Endeavor to" and "but failure to mail such notice shall impose no obligation or liability of any kind upon the company, its agents or representatives" must be removed from the standard ACORD cancellation statement. These certificates must identify the City of Flint as the "Certificate Holder." Contractor must provide, upon request, certified copies of all insurance policies. If any of the above policies are due to expire during the term of this contract, Contractor shall deliver renewal certificates to 1101 S. Saginaw St., Room 203, Flint, MI 48502 Phone: (810)766-7340 Fax: (810) 766-7240 and copies of the new policies to the City of Flint at least ten days prior to the expiration date. Contractor shall ensure that all subcontractors utilized obtain and maintain all insurance coverage required by this provision.

**LEAVE BLANK INTENTIONALLY**

## **REQUIREMENTS / TABULATION**

**Water Pollution  
Control G-4652  
Beecher Rd. Flint, MI  
48532**

**FY 2021 WPC AQUEOUS FERROUS CHLORIDE**

**FURNISH AS REQUESTED FOR THE PERIOD OF 07/01/2020 TO 06/30/2022.**

**QUANTITIES (DOLLAR AMOUNTS) ARE NOT GUARANTEED.**

**SUPPLY AQUEOUS AFERROUS CHLORIDE ON AN AS-NEEDED BASIS AS OUTLINED IN THE ATTACHED SPECIFICATIONS.**

**PRICING PER PROPOSAL #21000504**

**FOR FURTHER INFORMATION, PLEASE CONTACT JEANNETTE BEST, WPC SUPERVISOR OR PLANT OPERATIONS AT 810-766-7210 EXTENSION 3826.**

***Only the specifier has the responsibility and judgment for determining whether a proposed substitution is an "or equal or exceeding" specification. Mfg., model #, and supporting documentation of specifications for alternates must be provided.***

**PROPOSAL**

PVS Technologies, Inc.

Bid of \_\_\_\_\_ (hereinafter called **Bidder**), organized and existing under the laws of the State of Michigan doing business as Corporation \_\_\_\_\_ ('Corporation', 'Partnership', and 'Individual' as applicable) to the City of Flint, Michigan (hereinafter called **Owner**).

In compliance with the **Owner's** Advertisement for Bids, **Bidder** hereby proposes to supply Aqueous Ferrous Chloride in 5,000-10,000 gallon tank loads in strict accordance with the **Bid Specifications** at the price stated below.

By submission of this bid each **Bidder** certifies (in case of a joint bid, each party thereto certifies as to his own organization) that this bid has been arrived at independently and without consultation, communication, or agreement with any other bidders or with any competitor.

Bidder hereby agrees to supply Aqueous Ferrous Chloride for a **two (2) year period from 07/01/2020 to 06/30/2022** as detailed in the **Bid Specifications** at the rate of \$ 0.59 per pound of iron, F.O.B. Phosphate Building, Water Pollution Control Facility, G-4652 Beecher Road, Flint, Michigan 48532.

Point of shipment will be Detroit, Michigan

Carrier(s) will be PVS Transportation, Inc.

Lead time required to fill an order shall be no more than 48 hours.

The **Bidder** understands that the **Owner** reserves the right to reject any and all bids and that no guarantee of quantity under this proposal is implied.

Dated and signed this 01 day of May, 2020

Submitted by:   
(Signature)

Vice President of Sales & Marketing  
(Title)

10900 Harper Avenue  
(Address)

Detroit, MI 48213  
(City, State)

313-571-1100 313-571-6765  
(Telephone) (Fax)

bids@pvschemicals.com  
(Email/Website)

## **INSTRUCTIONS TO BIDDERS**

### **RECEIPT OF BID**

Sealed bids are invited for the supply of Aqueous Ferrous Chloride listed as "Supply Aqueous Ferrous Chloride" for the City of Flint, Michigan and will be received by the City of Flint, Department of Purchases and Supplies, Room 304, City Hall, 1101 South Saginaw Street, Flint, Michigan 48502, up to **1:00 P.M. local time on May 6, 2020**, at which time they will be opened and publicly read.

**Proposals shall be submitted in duplicate.**

### **RELEASE OF BID SPECIFICATIONS**

**Bid Specifications** may be procured by **Bidders** from the Department of Purchases and Supplies, Room 304, City Hall, 1101 South Saginaw, Flint, Michigan 48502.

### **LOCAL PREFERENCE**

Bidders located within the corporate limits of Flint, Michigan, may be given a five- percent (5%) competitive advantage.

### **CERTIFICATE OF ANALYSIS**

A certificate of analysis for materials bid, which includes as a minimum the parameters listed under Chemical Specifications, shall be provided with bid documents.

### **GENERAL CONDITIONS**

#### **QUANTITIES**

The quantity of material required will be approximately 2 million Lbs. per the requirements of the **Owner**. No guarantee of quantity is implied under the terms of this bid. **Bidder** shall have no claim for loss of anticipated profits or any other damages due to any deductions from or additions to these quantities.

#### **DELIVERIES**

All deliveries shall be made between the hours of 9 a.m. and 2 p.m. local time, Monday through Friday. All costs incurred by the **Owner** due to the **Carrier's** failure to make delivery between the hours of 9 a.m. and 2 p.m. shall be charged to the **Bidder's** account. The **Owner** reserves the right to schedule deliveries during off hours with no additional cost.

**Bidder** shall include the cost of the use of all containers, all freight/handling for all quantities in the bid purchase price.

Deliveries shall be made FOB Destination, Phosphate Building, City of Flint, Water Pollution Control Facilities, G-4652 Beecher Road, Flint, Michigan 48532.

**Owner's** employees shall direct the **Carrier** in unloading shipments and connecting to the **Owner's** equipment.

#### **BID COVERAGE**

The period covered by the proposal shall be **two (2) year** from the date of issuance of a purchase order by the **Owner**, the year being **July 1, 2020 to June 30, 2022**.

#### **FAILURE TO DELIVER MATERIAL**

Should the **Bidder** fail to deliver the material specified in the amount ordered, the **Owner** reserves the right to procure such material as has been ordered from other sources. If the cost of the material purchased is greater than the amount specified under the terms and conditions of the **Bid Specifications**, the difference shall be charged to the **Bidder**.

#### **REQUIRED DOCUMENTATION AND SAMPLES**

Upon delivery of each shipment, **Bidder** shall provide documentation indicating the following: material identification; tare weight; net weight; gross weight; appropriate safety kit identity to address leaks; percent iron; pH; specific gravity; and Safety Data Sheet(s).

**Owner** reserves the right to refuse any delivery which fails to meet bid specifications or lacks the required documentation.

**Bidder** and an **Owner's** representative shall take a 200 mL sample of material approximately halfway through each delivery.

**Bidder** shall furnish a receipt of materials specifying the number pounds of Aqueous Ferrous Chloride delivered, with the supporting weight tickets, and the purchase order number as issued by the **Owner**.

**Bidder** shall furnish the **Owner** a copy of the Material Safety Data Sheet for Aqueous Ferrous Chloride, and any acids present in the solution, prior to initial shipment of materials.

**Carrier** shall have a copy of the Material Safety Data Sheet for Aqueous Ferrous Chloride, and any acids present in the solution, located in the truck cab and provide a copy to the **Owner** with each delivery.

## **BILLING PROCEDURE**

**Bidder** shall submit invoices to: [accountspayable@cityofflint.com](mailto:accountspayable@cityofflint.com)

The City now conducts all business using electronic fund transfers exclusively. Vendors must become enrolled in the City's financial system (Payables) by submitting a form W-9 and ACH, which is available on the City's website or through its Finance Department.

Testing to determine Iron content for billing purposes may also be performed by the **Owner**.

## **MATERIAL SPECIFICATIONS**

### **EQUIPMENT SPECIFICATIONS**

**Carrier** shall supply an ANSI 3" 4 bolt PVC flanged connection and at least ten (10) feet of hose to connect to the **Owner's** equipment for unloading material.

**Carrier** shall supply all equipment necessary to deliver air pressure to the bulk containers for unloading of material.

**Carrier** shall deliver full quantity of material for each order in one (1) shipment.

**Bidder** shall provide any gasket material required to ensure an air-tight connection to the **Owner's** equipment.

**Bidder** shall provide certified gross, tare, and net weight tickets with all shipments at time of delivery.

**Owner** reserves the right to refuse material, at the **Bidder's** expense, if: the integrity of the equipment or **Carrier's** tank liner has been compromised, leaks, or is contaminated by previously hauled materials; or the **Carrier** fails to provide required documentation.

### **LOAD SPECIFICATIONS**

Shipments shall be more than 4,500 gallons of solution.

## CHEMICAL SPECIFICATIONS

Material provided shall be Aqueous Ferrous Chloride with Iron content range of 6% - 12% of the solution. Material must be free of compounds which would: corrode or encrust the **Owner's** ferrous chloride pumps, piping or storage tanks; interfere with the biological process; or limit sludge disposal alternatives of this facility.

Impurities must **not** exceed the following: \*\*\*

Cadmium	2.5 mg/L
Copper	18.0 mg/L
Lead	45.0 mg/L
Nickel	27.0 mg/L
Zinc	9.0 mg/L
Chromium	13.0 mg/L
Mercury	0.01 mg/L
Cobalt	2.0 mg/L
Molybdenum	1.0 mg/L
Arsenic	1.0 mg/L
Cyanide	5.2 mg/L
Silver	1.0 mg/L

Total suspended solids must not exceed **150 mg/l**.

**Owner** reserves the right to return to the **Bidder**, at the **Bidder's** expense, any material deemed unfit and/or not conforming to the required **CHEMICAL SPECIFICATIONS**.

Inability to meet the chemical specifications as indicated in the **Bid Specifications** shall result in the immediate termination of the purchase agreement.

## AFFIDAVIT OF COMPLIANCE

The **Bidder** shall furnish an affidavit attesting that all Aqueous Ferrous Chloride furnished as a result of this bid complies with all applicable standards and conforms to the requirements of the Section Titled **CHEMICAL SPECIFICATIONS**. The **Owner** will use in house analytical work to assure compliance with bid specifications.

## BASIS FOR REJECTION

If the Aqueous Ferrous Chloride does not meet the requirements of this bid specification, the **Owner** shall provide a notice of nonconformance to the **Bidder** within 2 working days after receipt of the shipment. The results of the **Owner's** test shall prevail unless the **Bidder** provides written notification to the **Owner** within 1 day after the receipt of noncompliance that a retest is desired. The **Owner** will retest the Aqueous Ferrous Chloride and verify the results.

\*\*\*Typical heavy metals for ferrous chloride supplied by PVS Technologies attached.



**THIS PAGE MUST BE COMPLETED AND INCLUDED WITH SUBMITTAL:**

The undersigned hereby certifies, on behalf of the respondent named in this Certification (the "Respondent"), that the information provided in this offer submitted to the City of Flint is accurate and complete, and that I am duly authorized to submit same. I hereby certify that the Respondent has reviewed all documents and requirements included in this offer and accept its terms and conditions

How long will it take to complete this project? Under contract terms.

Terms: Zero Net 30 Days Dest: Include Fed. ID#: 38-1949201

CONTRACTOR NAME: PVS Technologies, Inc.

ADDRESS: 10900 Harper Avenue

CITY/STATE/ZIP: Detroit Michigan 48213

PHONE: 313-571-1100 FAX: 313-571-6765

SIGNED:  DATE: May 1, 2020

PRINTED: Craig Mikkelson TITLE: Vice President of Sales & Marketing

**\*\*\*Failure to use this bid form shall result in bid disqualification.**

No work on this project shall commence without prior written notice to proceed from the project manager.

**LIST OF REFERENCES: (3) SIMILAR SCOPE OF WORK FROM THE LAST 5 YEARS**

Providing the following contact information enables the City of Flint to contact those accounts as references.

**Reference #1:**

Company/Municipality: City of Jackson  
Contact Person: Shelly Allard Title: Purchasing  
Address: 161 West Michigan Avenue  
City: Jackson State: Michigan Zip: 49201  
Telephone: 517-788-4020 Fax: \_\_\_\_\_  
Email: \_\_\_\_\_  
Type of Project: Supplying Ferrous Chloride  
Project Timeline (Dates): 07/01/2019-06/30/2020 Budget: \_\_\_\_\_

**Reference #2:**

Company/Municipality: City of Mt. Clemens  
Contact Person: Terese G. Lucci Title: Purchasing  
Address: One Crocker Blvd.  
City: Mt. Clemens State: Michigan Zip: 48043  
Telephone: 586-469-6818 Fax: \_\_\_\_\_  
Email: \_\_\_\_\_  
Type of Project: Supplying Ferric Chloride  
Project Timeline (Dates): 07/01/2020-06/30/2020 Budget: \_\_\_\_\_

CITY OF FLINT PROPOSAL NO.21000504 – SUPPLY AQUEOUS FERROUS CHLORIDE @ WATER POLLUTION CONTROL

Reference #3:

Company/Municipality: Pittsburgh Water & Sewer Authority  
Contact Person: Jim Tracey Title: Purchasing  
Address: 1200 Penn Avenue, 2nd Floor / Penn Liberty Plaza 1  
City: Pittsburgh State: PA Zip: 15222  
Telephone: 215-255-8800 Fax: \_\_\_\_\_  
Email: jtracey@pgh2o.com  
Type of Project: Supplying Ferric Chloride  
Project Timeline (Dates): 01/01/2016-12/31/2020 Budget: \_\_\_\_\_

**THE FOLLOWING PAGES MUST BE COMPLETED AND INCLUDED WITH SUBMITTAL IN THE FOLLOWING ORDER.**

**Checklist:**

- Cover Sheet
- Pricing Page
- W-9
- List of References
- Certification Regarding Debarment, Suspension, and Other Responsibility Matters
- Qualifications
- Licenses
- Certificate of Insurance
- City of Flint, Michigan Affidavit

***Failure to provide the following items with your bid shall be cause for rejection of bid as non-responsive and/or non-responsible. It is the responsibility of the bidder to ensure that it has received all addenda and to include signed copies with their bid.***

**Certification Regarding  
Debarment, Suspension, and Other Responsibility Matters**

The prospective participant certifies, to the best of its knowledge and belief, that it and its principals:

- 1) Are not presently or proposed to be debarred or suspended, declared ineligible, or voluntarily excluded from federal, state, or local (hereinafter "public") transactions;
- 2) Have not within a three-year period preceding this Agreement been convicted of or had a civil judgment rendered against them for
  - i. Fraud or commission of a criminal offence in connection with obtaining, attempting to obtain, or performing a public transaction or contract under a public transaction,
  - ii. Violation of federal or state antitrust laws, or
  - iii. Embezzlement, theft, forgery, bribery, falsification or destruction of records, making false statements or receiving stolen property;
- 3) Have not within the preceding three years had a public transaction terminated for cause or default; and
- 4) Are not presently indicted for or otherwise criminally or civilly charged by a public entity with commission of any of the offenses enumerated under the above.

I understand that a false statement on this certification may be grounds for the rejection of this proposal or the termination of the award.

Craig Mikkelson / Vice President of Sales & Marketing  
Name and Title of Authorized Representative

PVS Technologies, Inc.  
Name of Participant Agency or Firm

  
Signature of Authorized Representative

May 1, 2020  
Date

I am unable to certify to the above statement. Attached is my explanation.

**CITY OF FLINT, MICHIGAN AFFIDAVIT  
AFFIDAVIT FOR INDIVIDUAL**

STATE OF \_\_\_\_\_

S.S.

COUNTY OF \_\_\_\_\_

\_\_\_\_\_ being duly sworn,  
deposes and says that he is the person making the above bid; and that said bid is genuine and not sham or  
collusive, and is not made in the interest of or on behalf of any person not therein named, and that he has not  
directly or indirectly induced or solicited any bidder to put in a sham bid; that he has not directly or indirectly  
induced or solicited any other person or corporation to refrain from bidding, and that he has not in any manner  
sought by collusion to secure himself any advantage over other bidders.

Subscribed and sworn to before me at \_\_\_\_\_ in said County and State,

this \_\_\_\_\_ day of \_\_\_\_\_ A.D. 20 \_\_\_\_\_,

\_\_\_\_\_  
\*Notary Public, \_\_\_\_\_ County, \_\_\_\_\_

My Commission expires \_\_\_\_\_, 20 \_\_\_\_\_

CITY OF FLINT PROPOSAL NO.21000504 – SUPPLY AQUEOUS FERROUS CHLORIDE @ WATER POLLUTION CONTROL

FOR CORPORATION

STATE OF Michigan

S.S.

COUNTY OF Wayne

Craig Mikkelson being duly sworn, deposes and says that she/he/they  
is Vice President of Sales & Marketing of PVS Technologies, Inc.  
(Official Title) (Name of Corporation)

a corporation duly organized and doing business under the laws of the State of Michigan  
the corporation making the within and foregoing bid; that he executed said bid in behalf of said corporation by  
authority of its Board of Directors; that said bid is genuine and not sham or collusive and is not made in the  
interests of or on behalf of any person not herein named, and that he has not and said bidder has not directly or  
indirectly induced or solicited any other person or corporation to refrain from bidding; that he has not and said  
bidder has not in any manner sought by collusion to secure to himself or to said corporation an advantage over  
other bidders.

Subscribed and sworn to before me at 10900 Harper Avenue, Detroit Michigan, in said County and State,

this 1st day of May, A.D. 20/20

Craig Mikkelson  
\*Notary Public, Michigan County, Wayne

My Commission expires May 1, 20 20

Eileen McDonnell

EILEEN MCDONNELL  
Notary Public, State of Michigan  
Wayne County, Michigan  
My Commission Expires Dec 23, 20 20  
Acting in Wayne County

**FOR PARTNERSHIP**

STATE OF \_\_\_\_\_

S.S.

COUNTY OF \_\_\_\_\_

\_\_\_\_\_ being duly sworn,  
deposes and says that he is a member of the firm of \_\_\_\_\_, a co-  
partnership, making the above bid; that he is duly authorized to make said bid on behalf of said co-partnership;  
that said bid is genuine and not sham or collusive, and is not made in the interest of or on behalf of any person  
not therein named, and that he has and said bidder has not directly or indirectly induced or solicited any other  
person or corporation to refrain from bidding, and that he has not and said bidder has not in any manner sought  
by collusion to secure to himself or to said bidder any advantage over other bidders.

Subscribed and sworn to before me at \_\_\_\_\_, in said County and State,

this \_\_\_\_\_ day of \_\_\_\_\_, A.D. 20\_\_\_\_,

\_\_\_\_\_  
\*Notary Public, \_\_\_\_\_ County, \_\_\_\_\_

My Commission expires \_\_\_\_\_, 20\_\_\_\_



FOR AGENT

STATE OF \_\_\_\_\_

S.S.

COUNTY OF \_\_\_\_\_

\_\_\_\_\_ being duly sworn, deposes and says that he executed the within and foregoing bid in behalf of \_\_\_\_\_ the bidder therein named, he having been theretofore lawfully authorized, as the agent of said bidder, so to do; that said bid is genuine and not sham or collusive and not made in the interests of or on behalf of any person not therein named, and that he has not and said bidder has not directly or indirectly induced or solicited any bidder to put in a sham bid; that he has not and said bidder has not directly or indirectly induced or solicited any other person or corporation to refrain from bidding, and that he has not and said bidder has not in any manner sought by collusion to secure to himself or to said bidder any advantage over other bidders.

Subscribed and sworn to before me at \_\_\_\_\_, in said County and State, this \_\_\_\_\_ day of \_\_\_\_\_, A.D. 20\_\_\_\_\_

\_\_\_\_\_  
\*Notary Public, \_\_\_\_\_ County, \_\_\_\_\_

My Commission expires \_\_\_\_\_, 20\_\_\_\_\_

*NOTE: If executed outside of the State of Michigan, certificate by the Clerk of the Court of Record, authenticating the Notary's Signature and authority should be attached.*

## Request for Taxpayer Identification Number and Certification

**Give Form to the  
 requester. Do not  
 send to the IRS.**

▶ Go to [www.irs.gov/FormW9](http://www.irs.gov/FormW9) for instructions and the latest information.

Print or type. See specific instructions on page 3.	1 Name (as shown on your income tax return). Name is required on this line; do not leave this line blank. <b>PVS Technologies, Inc.</b>	
	2 Business name/disregarded entity name, if different from above	
	3 Check appropriate box for federal tax classification of the person whose name is entered on line 1. Check only one of the following seven boxes. <input type="checkbox"/> Individual/sole proprietor or single-member LLC <input checked="" type="checkbox"/> C Corporation <input type="checkbox"/> S Corporation <input type="checkbox"/> Partnership <input type="checkbox"/> Trust/estate <input type="checkbox"/> Limited liability company. Enter the tax classification (C=C corporation, S=S corporation, P=Partnership) ▶ _____ <small>Note: Check the appropriate box in the line above for the tax classification of the single-member owner. Do not check LLC if the LLC is classified as a single-member LLC that is disregarded from the owner unless the owner of the LLC is another LLC that is not disregarded from the owner for U.S. federal tax purposes. Otherwise, a single-member LLC that is disregarded from the owner should check the appropriate box for the tax classification of its owner.</small> <input type="checkbox"/> Other (see instructions) ▶ _____	
	4 Exemptions (codes apply only to certain entities, not individuals; see instructions on page 3): Exempt payee code (if any) _____ Exemption from FATCA reporting code (if any) _____ <small>(Applies to accounts maintained outside the U.S.)</small>	
	5 Address (number, street, and apt. or suite no.) See instructions. <b>10900 Harper Avenue</b>	Requester's name and address (optional)
	6 City, state, and ZIP code <b>Detroit, MI 48213</b>	
	7 List account number(s) here (optional)	

<b>Part I Taxpayer Identification Number (TIN)</b>																																														
Enter your TIN in the appropriate box. The TIN provided must match the name given on line 1 to avoid backup withholding. For individuals, this is generally your social security number (SSN). However, for a resident alien, sole proprietor, or disregarded entity, see the instructions for Part I, later. For other entities, it is your employer identification number (EIN). If you do not have a number, see <i>How to get a TIN</i> , later.																																														
<b>Note:</b> If the account is in more than one name, see the instructions for line 1. Also see <i>What Name and Number To Give the Requester</i> for guidelines on whose number to enter.																																														
	<table border="1" style="width: 100%; border-collapse: collapse;"> <tr> <td colspan="9" style="text-align: center;">Social security number</td> </tr> <tr> <td style="width: 20px; height: 20px;"></td> <td style="width: 20px; height: 20px;"></td> <td style="width: 20px; height: 20px;"></td> <td style="width: 20px; height: 20px;"></td> <td style="width: 20px; height: 20px;"></td> <td style="width: 20px; height: 20px;"></td> <td style="width: 20px; height: 20px;"></td> <td style="width: 20px; height: 20px;"></td> <td style="width: 20px; height: 20px;"></td> </tr> <tr> <td colspan="9" style="text-align: center;">OR</td> </tr> <tr> <td colspan="9" style="text-align: center;">Employer identification number</td> </tr> <tr> <td style="width: 20px; height: 20px; text-align: center;">3</td> <td style="width: 20px; height: 20px; text-align: center;">8</td> <td style="width: 20px; height: 20px; text-align: center;">-</td> <td style="width: 20px; height: 20px; text-align: center;">1</td> <td style="width: 20px; height: 20px; text-align: center;">9</td> <td style="width: 20px; height: 20px; text-align: center;">4</td> <td style="width: 20px; height: 20px; text-align: center;">9</td> <td style="width: 20px; height: 20px; text-align: center;">2</td> <td style="width: 20px; height: 20px; text-align: center;">0</td> </tr> </table>	Social security number																		OR									Employer identification number									3	8	-	1	9	4	9	2	0
Social security number																																														
OR																																														
Employer identification number																																														
3	8	-	1	9	4	9	2	0																																						

<b>Part II Certification</b>	
Under penalties of perjury, I certify that:	
1. The number shown on this form is my correct taxpayer identification number (or I am waiting for a number to be issued to me); and	
2. I am not subject to backup withholding because: (a) I am exempt from backup withholding, or (b) I have not been notified by the Internal Revenue Service (IRS) that I am subject to backup withholding as a result of a failure to report all interest or dividends, or (c) the IRS has notified me that I am no longer subject to backup withholding; and	
3. I am a U.S. citizen or other U.S. person (defined below); and	
4. The FATCA code(s) entered on this form (if any) indicating that I am exempt from FATCA reporting is correct.	
<b>Certification instructions.</b> You must cross out item 2 above if you have been notified by the IRS that you are currently subject to backup withholding because you have failed to report all interest and dividends on your tax return. For real estate transactions, item 2 does not apply. For mortgage interest paid, acquisition or abandonment of secured property, cancellation of debt, contributions to an individual retirement arrangement (IRA), and generally, payments other than interest and dividends, you are not required to sign the certification, but you must provide your correct TIN. See the instructions for Part II, later.	

<b>Sign Here</b>	Signature of U.S. person ▶ <i>Eileen McDonnell</i>	Date ▶ <i>5/4/2020</i>
------------------	--	------------------------

### General Instructions

Section references are to the Internal Revenue Code unless otherwise noted.

**Future developments.** For the latest information about developments related to Form W-9 and its instructions, such as legislation enacted after they were published, go to [www.irs.gov/FormW9](http://www.irs.gov/FormW9).

### Purpose of Form

An individual or entity (Form W-9 requester) who is required to file an information return with the IRS must obtain your correct taxpayer identification number (TIN) which may be your social security number (SSN), individual taxpayer identification number (ITIN), adoption taxpayer identification number (ATIN), or employer identification number (EIN), to report on an information return the amount paid to you, or other amount reportable on an information return. Examples of information returns include, but are not limited to, the following.

- Form 1099-DIV (dividends, including those from stocks or mutual funds)
- Form 1099-MISC (various types of income, prizes, awards, or gross proceeds)
- Form 1099-B (stock or mutual fund sales and certain other transactions by brokers)
- Form 1099-S (proceeds from real estate transactions)
- Form 1099-K (merchant card and third party network transactions)
- Form 1098 (home mortgage interest), 1098-E (student loan interest), 1098-T (tuition)
- Form 1099-C (canceled debt)
- Form 1099-A (acquisition or abandonment of secured property)

Use Form W-9 only if you are a U.S. person (including a resident alien), to provide your correct TIN.

*If you do not return Form W-9 to the requester with a TIN, you might be subject to backup withholding. See What is backup withholding, later.*



## **PVS Technologies, Inc.**

10900 Harper Avenue • Detroit, Michigan 48213  
Phone: 313-921-1200 • Fax: 313-579-1675

May 1, 2020

### **Affidavit of Compliance**

This affidavit is to confirm that all Aqueous Ferrous Chloride supplied by PVS Technologies to the City of Flint complies with all applicable standards and conforms to the requirements of the section titled CHEMICAL SPECIFICATIONS with the exception of the heavy metals. The typical heavy metals of ferrous chloride to be supplied by PVS Technologies are attached and are the same as the City of Flint has historically been supplied by PVS Technologies.

Signed: \_\_\_\_\_

  
Craig Mikkelson

Date: \_\_\_\_\_

5/1/20

## Plant Quarterly Composite Metals Analysis

<b>Product:</b>	<b>Ferrous Chloride</b>	
<b>Plant:</b>	<b>Detroit, MI</b>	
<b>Quarter:</b>	<b>4Q 2019</b>	
<b>Metal</b>	<b>Result (mg/Kg)</b>	<b>EOL</b>
<b>Arsenic</b>	<b>N/D</b>	<b>0.50</b>
<b>Barium</b>	<b>1.1</b>	<b>0.25</b>
<b>Beryllium</b>	<b>N/D</b>	<b>0.025</b>
<b>Cadmium</b>	<b>N/D</b>	<b>0.50</b>
<b>Chromium</b>	<b>69</b>	<b>0.50</b>
<b>Copper</b>	<b>55</b>	<b>0.25</b>
<b>Antimony</b>	<b>5.2</b>	<b>5.0</b>
<b>Mercury</b>	<b>N/D</b>	<b>0.002</b>
<b>Magnesium</b>	<b>48</b>	<b>2.5</b>
<b>Manganese</b>	<b>440</b>	<b>0.75</b>
<b>Molybdenum</b>	<b>12</b>	<b>0.25</b>
<b>Silver</b>	<b>N/D</b>	<b>0.25</b>
<b>Nickel</b>	<b>22</b>	<b>0.50</b>
<b>Titanium</b>	<b>19</b>	<b>0.25</b>
<b>Lead</b>	<b>24</b>	<b>0.50</b>
<b>Selenium</b>	<b>6.8</b>	<b>0.50</b>
<b>Zinc</b>	<b>14</b>	<b>0.50</b>
<b>Vanadium</b>	<b>5.3</b>	<b>0.25</b>
<b>Sulfur</b>	<b>97</b>	<b>13</b>
<b>Thallium</b>	<b>N/D</b>	<b>1.3</b>

N/D = Not Detected

N/T = Not tested

Document Number.: TAFU074	Page 1 of 1	Revision No.: 1	Revision Date: 2/23/16
------------------------------	-------------	--------------------	---------------------------



# CERTIFICATE OF LIABILITY INSURANCE

DATE (MM/DD/YYYY)  
03/25/2020

THIS CERTIFICATE IS ISSUED AS A MATTER OF INFORMATION ONLY AND CONFERS NO RIGHTS UPON THE CERTIFICATE HOLDER. THIS CERTIFICATE DOES NOT AFFIRMATIVELY OR NEGATIVELY AMEND, EXTEND OR ALTER THE COVERAGE AFFORDED BY THE POLICIES BELOW. THIS CERTIFICATE OF INSURANCE DOES NOT CONSTITUTE A CONTRACT BETWEEN THE ISSUING INSURER(S), AUTHORIZED REPRESENTATIVE OR PRODUCER, AND THE CERTIFICATE HOLDER.

**IMPORTANT:** If the certificate holder is an ADDITIONAL INSURED, the policy(ies) must have ADDITIONAL INSURED provisions or be endorsed. If SUBROGATION IS WAIVED, subject to the terms and conditions of the policy, certain policies may require an endorsement. A statement on this certificate does not confer rights to the certificate holder in lieu of such endorsement(s).

<b>PRODUCER</b> Ralph C. Wilson Agency, Inc  Box 5088 Southfield MI 48066-5088		<b>CONTACT NAME:</b> Lisa Case <b>PHONE (A/C No. Ext.):</b> (248) 355-1414 <b>E-MAIL:</b> llscac@rcwa.net <b>ADDRESS:</b> <b>FAX (A/C No.):</b> (248) 304-0877	
<b>INSURED</b> PVS Technologies Inc Pressure Vessel Services Inc 10900 Harper Avenue Detroit MI 48213		<b>INSURER(S) AFFORDING COVERAGE</b> <b>INSURER A:</b> Amersure Mutual Insurance Company <b>NAIC #</b> 23398 <b>INSURER B:</b> <b>INSURER C:</b> <b>INSURER D:</b> <b>INSURER E:</b> <b>INSURER F:</b>	

**COVERAGES** CERTIFICATE NUMBER: 20/21 Master REVISION NUMBER:

THIS IS TO CERTIFY THAT THE POLICIES OF INSURANCE LISTED BELOW HAVE BEEN ISSUED TO THE INSURED NAMED ABOVE FOR THE POLICY PERIOD INDICATED. NOTWITHSTANDING ANY REQUIREMENT, TERM OR CONDITION OF ANY CONTRACT OR OTHER DOCUMENT WITH RESPECT TO WHICH THIS CERTIFICATE MAY BE ISSUED OR MAY PERTAIN, THE INSURANCE AFFORDED BY THE POLICIES DESCRIBED HEREIN IS SUBJECT TO ALL THE TERMS, EXCLUSIONS AND CONDITIONS OF SUCH POLICIES. LIMITS SHOWN MAY HAVE BEEN REDUCED BY PAID CLAIMS.

REF. LTR	TYPE OF INSURANCE	INDUSTRY	REQD	WYED	POLICY NUMBER	POLICY EFF. DATE (MM/DD/YYYY)	POLICY EXP. DATE (MM/DD/YYYY)	LIMITS
A	<input checked="" type="checkbox"/> COMMERCIAL GENERAL LIABILITY <input type="checkbox"/> CLAIMS-MADE <input checked="" type="checkbox"/> OCCUR  GEN'L AGGREGATE LIMIT APPLIES PER: <input type="checkbox"/> POLICY <input type="checkbox"/> PRO-JECT <input checked="" type="checkbox"/> LOC OTHER:				GL0125812	04/01/2020	04/01/2021	EACH OCCURRENCE \$ 1,500,000 DAMAGE TO RENTED PREMISES (Ea occurrence) \$ 1,000,000 MED EXP (Any one person) \$ 5,000 PERSONAL & ADV INJURY \$ 1,500,000 GENERAL AGGREGATE \$ 4,000,000 PRODUCTS - COMPROP AGG \$ 2,500,000
A	<input checked="" type="checkbox"/> AUTOMOBILE LIABILITY <input type="checkbox"/> ANY AUTO <input type="checkbox"/> OWNED AUTOS ONLY <input type="checkbox"/> HIRED AUTOS ONLY <input type="checkbox"/> SCHEDULED AUTOS <input type="checkbox"/> NON-OWNED AUTOS ONLY				CA1049675	04/01/2020	04/01/2021	COMBINED SINGLE LIMIT (Ea accident) \$ 5,000,000 BODILY INJURY (Per person) \$ BODILY INJURY (Per accident) \$ PROPERTY DAMAGE (Per accident) \$
	<input type="checkbox"/> UMBRELLA LIAB <input type="checkbox"/> EXCESS LIAB <input type="checkbox"/> OCCUR <input type="checkbox"/> CLAIMS-MADE DED RETENTION \$							EACH OCCURRENCE \$ AGGREGATE \$
A	WORKERS COMPENSATION AND EMPLOYERS' LIABILITY ANY PROPRIETOR/PARTNER/EXECUTIVE OFFICER/MEMBER EXCLUDED? (Mandatory in MI) If yes, describe under DESCRIPTION OF OPERATIONS below	Y/N		N/A	WC0784044	04/01/2020	04/01/2021	<input checked="" type="checkbox"/> PER STATUTE <input type="checkbox"/> OTHER E.L. EACH ACCIDENT \$ 1,000,000 E.L. DISEASE - EA EMPLOYEE \$ 1,000,000 E.L. DISEASE - POLICY LIMIT \$ 1,000,000

DESCRIPTION OF OPERATIONS / LOCATIONS / VEHICLES (ACORD 101, Additional Remarks Schedule, may be attached if more space is required)

<b>CERTIFICATE HOLDER</b> *INFORMATIONAL CERTIFICATE*	<b>CANCELLATION</b> SHOULD ANY OF THE ABOVE DESCRIBED POLICIES BE CANCELLED BEFORE THE EXPIRATION DATE THEREOF, NOTICE WILL BE DELIVERED IN ACCORDANCE WITH THE POLICY PROVISIONS.
	AUTHORIZED REPRESENTATIVE 



# Safety Data Sheet

Revision Date Apr-04-2017

Item #10248/11055

Safety Data Sheet 3743

## 1. PRODUCT AND COMPANY IDENTIFICATION

Product Name Ferrous Chloride Solution  
 UN/ID No. UN1760  
 Synonyms Iron (II) Chloride  
 Recommended Use Water treatment chemical, Industrial wastewater treatment, Municipal wastewater treatment, Chrome reduction  
 Uses advised against Consumer uses: Private households (= general public = consumers).

**Company Name**  
 PVS Technologies, Inc.  
 10900 Harper Ave.  
 Detroit, MI 48213  
 (313) 571-1100  
 24 Hour Emergency Phone Number CHEMTREC 1-800-424-9300

## 2. HAZARDS IDENTIFICATION

### Classification

Acute toxicity - Oral	Category 4
Acute toxicity - Inhalation (Gases)	Category 4
Skin corrosion/irritation	Category 1
Serious eye damage/eye irritation	Category 1
May be corrosive to metals	Category 1

### Emergency Overview

#### DANGER

Hazard statements  
 Physical hazards

Causes severe skin burns and eye damage  
 Do not handle until all hazard precautions have been read and understood

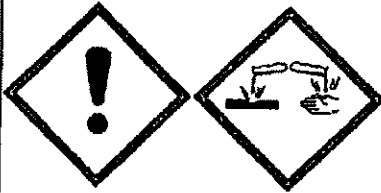

### Precautionary statements

#### Prevention

- Wash face, hands and any exposed skin thoroughly after handling
- Do not eat, drink or smoke when using this product
- Use only outdoors or in a well-ventilated area
- Do not breathe dust/fume/gas/mist/vapors/spray
- Wear protective gloves/protective clothing/eye protection/face protection
- Immediately call a POISON CENTER or doctor/physician
- Specific treatment (see section 4 on this Safety Data Sheet)
- Store locked up
- Dispose of contents/container to an approved waste disposal plant

#### Response

#### Storage Disposal

### Hazards not otherwise classified (HNOC)

None known.

### Other Information

Unknown Acute Toxicity

0% of the mixture consists of ingredient(s) of unknown toxicity

**Ferrous Chloride Solution****3. COMPOSITION/INFORMATION ON INGREDIENTS**

Chemical Name	CAS No.	EC No.	Weight-% *
Ferrous chloride	7758-94-3	231-843-4	16-30
Hydrogen chloride	7647-01-0	231-595-7	0-6

**4. FIRST AID MEASURES**

<b>General advice</b>	Call 911 or emergency medical service Remove and isolate contaminated clothing and shoes
<b>Eye contact</b>	• In case of contact with substance, immediately flush skin or eyes with running water for at least 20 minutes
<b>Skin Contact</b>	• For minor skin contact, avoid spreading material on unaffected skin
<b>-Inhalation</b>	• Move victim to fresh air • If breathing is irregular or stopped, administer artificial respiration • Administer oxygen if breathing is difficult
<b>Ingestion</b>	• Immediate medical attention is required • Do NOT induce vomiting • Rinse mouth • Drink 4 to 8 ounces (120-240 ml) of water or milk as soon as possible after ingestion. • Never give anything by mouth to an unconscious person • Call a physician or poison control center immediately
<b>Note to physician</b>	• Keep victim warm and quiet • Effects of exposure (inhalation, ingestion or skin contact) to substance may be delayed
<b>Self-protection for first aid personnel</b>	• Ensure that medical personnel are aware of the material(s) involved and take precautions to protect themselves • Do not use mouth-to-mouth method if victim ingested or inhaled the substance; give artificial respiration with the aid of a pocket mask equipped with a one-way valve or other proper respiratory medical device

**5. FIRE-FIGHTING MEASURES**

<b>Suitable extinguishing media</b>	• Dry chemical, CO2, alcohol-resistant foam or water spray • Dry chemical, CO2 or water spray
<b>Unsuitable extinguishing media</b>	• Move containers from fire area if you can do it without risk • Dike fire control water for later disposal; do not scatter the material • No information available
<b>Specific hazards arising from the chemical</b>	• Some are oxidizers and may ignite combustibles (wood, paper, oil, clothing, etc.)
<b>Protective equipment and precautions for firefighters</b>	• Wear a self-contained breathing apparatus and chemical protective clothing
<b>Flammable properties</b>	• Non-combustible, substance itself does not burn but may decompose upon heating to produce corrosive and/or toxic fumes • Contact with metals may evolve flammable hydrogen gas • Containers may explode when heated
<b>Explosive properties</b>	• No information available

**6. ACCIDENTAL RELEASE MEASURES**

<b>Personal precautions</b>	• ELIMINATE all ignition sources (no smoking, flares, sparks or flames in immediate area) • Do not touch damaged containers or spilled material unless wearing appropriate protective clothing
-----------------------------	---

## Ferrous Chloride Solution

### Environmental precautions

- Stop leak if you can do it without risk
- For small spills absorb material on dry rags, cat litter or similar absorbent material and dispose of in the trash
- For large spills, contain the material using barriers of absorbent pigs, clay absorbent or earth dams.
- US regulations require reporting spills of this material that could reach any surface waters. The toll-free phone number for the US Coast Guard National Response Center is 1-800-424-8802

### Methods for cleaning up

- Dike far ahead of liquid spill for later disposal
- Neutralize with soda ash or lime
- Soak up with inert absorbent material
- Take up mechanically, placing in appropriate containers for disposal
- Clean contaminated surface thoroughly
- Prevent product from entering drains
- Do not get water inside containers or in contact with substance

### Other Information

## 7. HANDLING AND STORAGE

### Advice on safe handling

- Use personal protective equipment as required
- Avoid contact with skin, eyes or clothing
- Ensure adequate ventilation, especially in confined areas
- In case of insufficient ventilation, wear suitable respiratory equipment
- Use only with adequate ventilation and in closed systems

### Storage Conditions

- Keep container tightly closed in a dry and well-ventilated place
- Keep out of the reach of children
- Keep containers tightly closed in a dry, cool and well-ventilated place
- Keep in properly labeled containers

### Incompatible materials

Contact with metals may evolve flammable hydrogen gas, Oxidizers, Strong bases, Reducing agents, Alcohols, Sulfides, Styrene, Incompatible with strong acids and bases, Incompatible with oxidizing agents

## 8. EXPOSURE CONTROLS/PERSONAL PROTECTION

Chemical Name	ACGIH TLV	OSHA PEL	NIOSH IDLH
Ferrous chloride 7758-94-3	TWA: 1 mg/m <sup>3</sup> Fe		TWA: 1 mg/m <sup>3</sup> Fe
Hydrogen chloride 7647-01-0	Ceiling: 2 ppm	Ceiling: 5 ppm Ceiling: 7 mg/m <sup>3</sup>	IDLH: 50 ppm Ceiling: 5 ppm Ceiling: 7 mg/m <sup>3</sup>

### Exposure Guidelines

#### Engineering Controls

Ensure adequate ventilation, especially in confined areas.

#### Individual protection measures, such as personal protective equipment

#### Respiratory protection

• A respiratory protection program that meets OSHA 1910.134 and ANSI Z88.2 requirements must be followed whenever workplace conditions warrant the use of a respirator.

#### Eye/Face protection

- Tight sealing safety goggles
- Face protection shield

#### Skin and body protection

• Wear suitable protective clothing

• Wear impervious protective clothing, including boots, gloves, lab coat, apron or coveralls, as appropriate, to prevent skin contact

#### General Hygiene Considerations

- When using do not eat, drink or smoke
- Wash contaminated clothing before reuse
- Keep away from food, drink and animal feeding stuffs
- Contaminated work clothing should not be allowed out of the workplace
- Regular cleaning of equipment, work area and clothing is recommended
- Avoid contact with skin, eyes or clothing



## Ferrous Chloride Solution

- Take off all contaminated clothing and wash it before reuse
- Wear suitable gloves and eye/face protection

### 9. PHYSICAL AND CHEMICAL PROPERTIES

#### Information on basic physical and chemical properties

Physical state	Liquid
Appearance	aqueous solution
Color	green to yellow
Odor	Iron Slight acidic
Odor threshold	No information available

<u>Property</u>	<u>Values</u>	<u>Remarks • Method</u>
pH	<2.0	
Melting point/Freezing Point	-50 °C / -58 °F	solution (20 %)
Boiling point / boiling range	> 100 °C / 212 °F	
Flash point	No information available	
Evaporation rate	No information available	
Flammability (solid, gas)	No information available	
Flammability Limit in Air		
Upper flammability limit (%)	No information available	
Lower flammability limit (%)	No information available	
Vapor pressure	No information available	
Vapor density	No information available	
Specific Gravity	1.20	20% Solution @17.5°C
Water solubility	No information available	
Solubility in other solvents	No information available	
Partition coefficient	No information available	
Autoignition temperature	No information available	
Decomposition temperature	No information available	
Kinematic viscosity	No information available	
Dynamic viscosity	No information available	
Explosive properties	No information available	
Oxidizing properties	No information available	
<u>Other Information</u>		
Softening point °C	No information available	
Molecular weight	No information available	
VOC Content (%)	No information available	
Density	No information available	
Bulk density	10.00 Pounds per gallon (lb/gal)	

### 10. STABILITY AND REACTIVITY

Stability	<ul style="list-style-type: none"><li>• Stable under recommended storage conditions</li></ul>
Conditions to avoid	<ul style="list-style-type: none"><li>• Elevated temperature</li><li>• Exposure to air or moisture over prolonged periods</li></ul>
Incompatible materials	<ul style="list-style-type: none"><li>• Contact with metals may evolve flammable hydrogen gas</li><li>• Oxidizers</li><li>• Strong bases</li><li>• Reducing agents</li><li>• Alcohols</li><li>• Sulfides</li><li>• Styrene</li><li>• Incompatible with strong acids and bases</li><li>• Incompatible with oxidizing agents</li></ul>
Hazardous Decomposition Products	<ul style="list-style-type: none"><li>• Thermal decomposition can lead to release of irritating and toxic gases and vapors</li></ul>
Possibility of Hazardous Reactions	<ul style="list-style-type: none"><li>• None under normal processing and storage</li></ul>

**Ferrous Chloride Solution**

**11. TOXICOLOGICAL INFORMATION**

Information on likely routes of exposure

**Principle Routes of Exposure**  
 -Inhalation                      -Inhalation, Skin Contact, Eye contact  
   Ingestion                        May cause irritation of respiratory tract. Avoid breathing vapors or mists.  
   Skin Contact                     May be harmful if swallowed.  
   Eye contact                      May cause skin irritation and/or dermatitis.  
   Contact with eyes may cause irritation.

Chemical Name	Oral LD50	Dermal LD50	Inhalation LC50
Ferrous chloride 7758-94-3	450 mg/kg (Rat)		
Hydrogen chloride 7647-01-0	238 - 277 mg/kg ( Rat )	> 5010 mg/kg ( Rabbit )	= 1.68 mg/L ( Rat ) 1 h

Information on toxicological effects

**Symptoms**                                      No information available  
Delayed and immediate effects as well as chronic effects from short and long-term exposure

**Sensitization**                                No information available.  
**Germ cell mutagenicity**                    No information available.  
**Carcinogenicity**                            The table below indicates whether each agency has listed any ingredient as a carcinogen. This product contains one or more substances which are classified by IARC as carcinogenic to humans (Group I), probably carcinogenic to humans (Group 2A) or possibly carcinogenic to humans (Group 2B).

Chemical Name	ACGIH	IARC	NTP	OSHA
Hydrogen chloride 7647-01-0		Group 3		X

*IARC (International Agency for Research on Cancer)  
 Not classifiable as a human carcinogen*

**Reproductive toxicity**                    No information available.  
**STOT - single exposure**                    No information available.  
**STOT - repeated exposure**                No information available.  
**Chronic toxicity**                            Chronic exposure to corrosive fumes/gases may cause erosion of the teeth followed by jaw necrosis. Bronchial irritation with chronic cough and frequent attacks of pneumonia are common. Gastrointestinal disturbances may also be seen. Avoid repeated exposure. Possible risk of irreversible effects. May cause adverse liver effects.  
**Target Organ Effects**                      Eyes, Gastrointestinal tract (GI), Liver, Respiratory system, Skin.  
**Aspiration hazard**                         No information available.

Numerical measures of toxicity - Product Information

**Unknown Acute Toxicity**                    0% of the mixture consists of ingredient(s) of unknown toxicity  
 The following values are calculated based on chapter 3.1 of the GHS document . mg/kg mg/l

**12. ECOLOGICAL INFORMATION**

Ecotoxicity

26% of the mixture consists of component(s) of unknown hazards to the aquatic environment

Persistence and degradability            No information available  
Bioaccumulation                            No information available

Other adverse effects                      No information available

**13. DISPOSAL CONSIDERATIONS**

**Disposal of wastes**                        • Dispose of in accordance with federal, state and local regulations  
   • Dispose of hazardous waste in a RCRA licensed facility



## Ferrous Chloride Solution

WHMIS Classification This product has been classified in accordance with the hazard criteria of the Controlled Products Regulations (CPR) and the MSDS contains all the information required by the CPR

WHMIS Classification Non-controlled

### US State Regulations

California Proposition 65 This product does not contain any Proposition 65 chemicals

### U.S. State Right-to-Know Regulations

Chemical Name	New Jersey	Massachusetts	Pennsylvania
Water 7732-18-5			X
Ferrous chloride 7758-94-3	X	X	X
Hydrogen chloride 7647-01-0	X	X	X

### DEA List I, List II

Chemical Name	U.S. - DEA - List I or Precursor Chemicals	U.S. - DEA - List II or Essential Chemicals
Hydrogen chloride 7647-01-0		50 gallon, Export Volume 27 kg, Export Weight 0.0 kg, Domestic Sales Weight

### International inventories

TSCA Complies  
 DSL/NDSL Complies  
 EINECS/ELINCS Complies  
 ENCS Does not comply  
 IECS Complies  
 KECL Complies  
 PICCS Complies  
 AICS Complies

### Legend:

TSCA - United States Toxic Substances Control Act Section 8(b) Inventory  
 DSL/NDSL - Canadian Domestic Substances List/Non-Domestic Substances List  
 EINECS/ELINCS - European Inventory of Existing Chemical Substances/European List of Notified Chemical Substances  
 ENCS - Japan Existing and New Chemical Substances  
 IECS - China Inventory of Existing Chemical Substances  
 KECL - Korean Existing and Evaluated Chemical Substances  
 PICCS - Philippines Inventory of Chemicals and Chemical Substances  
 AICS - Australian inventory of Chemical Substances

## 16. OTHER INFORMATION

<u>NFPA</u>	Health hazards 3	Flammability 0	Instability 0	Physical and Chemical Properties Personal protection D
<u>HMIS</u>	Health hazards 3	Flammability 0	Physical hazards 0	

Item # 10248/11055  
 Safety Data Sheet 3743  
 Revision Date Apr-04-2017  
 Issue Date Apr-04-2017  
 Version 1  
 Revision Note \*\*\* Updated value on SDS.

### Disclaimer

All information, statements, data, advice, and/or recommendations, including, without limitation, those relating to storage, loading/unloading, piping, and transportation (collectively referred to herein as "information") are believed to be accurate, reliable, and based on reliable industry and regulatory references. However, no representation or warranty,

Joyce A. McClane

CITY OF FLINT  
DEPARTMENT OF FINANCE  
Division of Purchases Supplies

BID DUE DATE:  
05/06/20

**P21-505 - LIQUID CATIONIC FOR GRAVITY BELT THICKENER @ WATER POLLUTION CONTROL**

**TWO (2) YEARS**

<b>COMPANY</b>		<b>Polydyne Inc</b>
270 Gallon Carboys (totes)	\$	1.180 (Per Lb)
Less than 4500 gallons via tanker, each load	\$	1.180 (Per Lb)
4500 gallons via tanker, each load	\$	1.140 (Per Lb)
<b>POINT OF SHIPMENT</b>		Rice GA
<b>CARRIER</b>		Common Carriers
<b>CITY, STATE</b>		Detroit, MI

*Bids must be reviewed and evaluated before award recommendation*

P21-505

REQUESTING DEPARTMENT  
WATER POLLUTION CONTROL

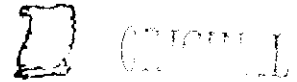

**CITY OF FLINT, MICHIGAN  
FINANCE DEPARTMENT  
DIVISION OF PURCHASES & SUPPLIES**

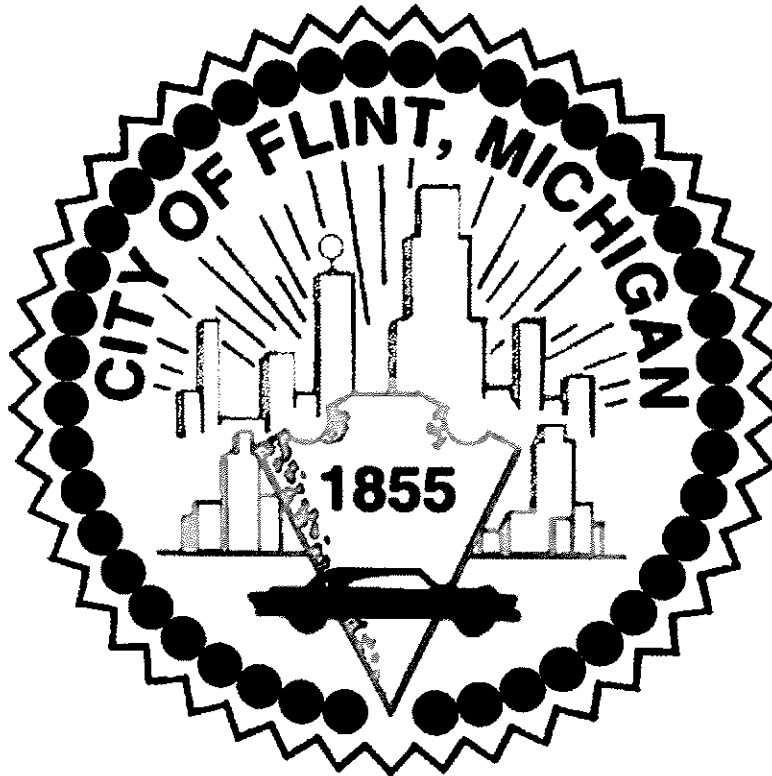

Sheldon A. Neeley, Mayor

**CITY OF FLINT PROPOSAL NO. 21000505**

**LIQUID CATIONIC FOR GRAVITY BELT THICKNER  
@ WATER POLLUTION CONTROL**

Date Posted: 04/19/20



## Liquid Ferrous Chloride

PVS Technologies Liquid Ferrous Chloride is a concentrated solution of Iron II Chloride ( $\text{FeCl}_2$ ) in water. Produced from high purity raw materials, it is the result of the dissolution of Iron Oxide and Iron in Hydrochloric Acid.

### Principal Uses in Wastewater Treatment

- Phosphate Precipitation and Removal
- Elimination of Sulfide Based Odors
- Reduction of Arsenic and Mercury
- Hexavalent Chrome Reduction
- Struvite Control
- Chlorite Reduction (NSF 60)

<b>Specifications</b>	
Appearance:	A clear green to hazel colored solution
Concentrations:	
$\text{FeCl}_2$	16% to 30%, as required
Free Acid as HCl	4.0% maximum
Insolubles	0.5% maximum
Specific gravity:	1.14 to 1.33
CAS No.:	7758-94-3
UN Classification:	Corrosive; NA1760; Ferrous Chloride Solution
	SQC data available on request

### Delivery

Available for shipping via the following options:

- 55 gallon drums
- 300 gallon totes
- 4,000 & 8,000 gallon tank trucks
- 17,000 gallon railcars

### Product Availability

Throughout North America – 8,000 gallon tankers only available in Michigan.

### Handling & Safety

Ferrous Chloride is considered to be hazardous by definition of the Hazard Communication Standard (29 CFR 1910.1200) and should be handled in a manner that is consistent with acceptable practices. Please obtain the Ferrous Chloride Material Safety Data Sheet for complete up-to-date information.

Document Number: TAFU007	Page 1 of 2	Revision No.: 3	Revision Date: 08/17/2016
-----------------------------	-------------	--------------------	------------------------------



Under normal situations the only protective equipment required in the use and handling of Liquid Ferrous Chloride are splash proof chemical goggles and rubber gloves. Liquid Ferrous Chloride will stain both clothing and skin and it is recommended that, to protect against this occurrence, other protect clothing be worn as is appropriate.

Ferrous Chloride reacts with many metals. However, most handling situations are reliably addressed through the use of common plastic materials such as FRP, PVC, Polyethylene, Polypropylene and Teflon. For additional information, please consult your equipment supplier.

**For additional information call: 313 571-1100**  
**To place an order call: 800 337-7428**

*PVS Technologies - Serving Water and Wastewater Plants throughout the World*

This bulletin and the information contained herein are offered solely for your consideration, investigation and verification. NO REPRESENTATIONS OR WARRANTIES, EXPRESS OR IMPLIED, OF MERCHANTABILITY OR OTHERWISE, ARE MADE OR CONTAINED HEREIN. PVS Technologies' exclusive responsibility for any claims, including claims based on negligence, arising in connection with the information contained herein or the subsequent purchase, use, storage or handling of the product will in no event exceed PVS Technologies' sale price for the product with respect to which damages are claimed. In no event will PVS Technologies be liable for any incidental or consequential damages arising in connection with the information contained herein or the subsequent purchase, use, storage or handling of the product. User accepts full responsibility for compliance with all applicable Federal, State and Local laws and regulations. Nothing contained herein will be construed to constitute permission or a recommendation to use the product in any process or formulation covered by a patent a patent application owned by PVS Technologies or by others.

Document Number: TAFU007	Page 2 of 2	Revision No.: 3	Revision Date: 08/17/2016
-----------------------------	-------------	--------------------	------------------------------





RESOLUTION NO.: 210261  
 PRESENTED: JUN - 6 2021  
 ADOPTED: \_\_\_\_\_

BY THE CITY ADMINISTRATOR:

**RESOLUTION TO POLYDYNE INC FOR LIQUID CATIONIC POLYMER (EMULSION)**

WHEREAS, the Water Pollution Control (WPC) facility operates a sludge dewatering process as part of its solids disposal program. Liquid Emulsion type cationic polymer is required to dewater sludge prior to transport to the landfill. Solids disposal is necessary to operate the plant and fulfill the requirements of WPC National Pollution Discharge Elimination System (NPDES) permit. WPC recommended the purchase of liquid cationic polymer (emulsion) for FY2021 and FY2022 to the only responsive bidder Polydyne Inc at \$1.14/lb for an annual total of \$98,000.

Account Number	Account Name	Amount
590-550.100-753.000	Treatment Chemicals	\$98,000.000
	<b>FY2022 GRAND TOTAL</b>	<b>\$98,000.00</b>

IT IS RESOLVED, that the appropriate City Officials are authorized to do all things necessary to enter into the second year of the contract with Polydyne Inc to provide liquid cationic polymer (emulsion) for FY2022, pending the adoption of the budget, for the amount of \$98,000.00.

APPROVED AS TO FORM:

Angela Wheeler  
Angela Wheeler (May 24, 2021 16:34 EDT)  
**Angela Wheeler, Chief Legal Officer**

APPROVED AS TO FINANCE:

Shelbi Frayer  
shelbi frayer (May 26, 2021 09:08 EDT)  
**Shelbi Frayer, Chief Financial Officer**

FOR THE CITY OF FLINT:

Clyde D Edwards  
Clyde D Edwards (May 27, 2021 13:15 EDT)  
**Clyde Edwards, City Administrator**

APPROVED BY CITY COUNCIL:

\_\_\_\_\_  
**Kate Fields, City Council President**

APPROVED AS TO PURCHASING:

Jennifer Ryan  
Jennifer Ryan (May 24, 2021 16:29 EDT)  
**Jenn Ryan, Deputy Finance Director**

REQ# 20-2923

CITY OF FLINT



PROPOSAL #21000505

RESOLUTION NO: 200250

PRESENTED: JUN 22 2020

ADOPTED: 6-24-2020

BY THE CITY ADMINISTRATOR:

**RESOLUTION TO POLYDYNE, INC FOR LIQUID CATIONIC POLYMER (EMULSION)**

The Division of Purchases & Supplies solicited proposals for Liquid Cationic Polymer (Emulsion) for two (2) fiscal year periods beginning 07/01/20 and ending 6/30/22 as requested by the Department of Public Works & Utilities.

Polydne, Inc., Detroit, Michigan was the only responsive bidder for said requirements. Funding for said services will come from the following account:

Dept.	Name of Account	Account #	Grant #	Amount
DPW	WATER FUND	591-545.200-740.000	N/A	\$98,000.00

IT IS RESOLVED, that the proper city officials, approve Polydne, Inc., for two (2) fiscal year periods beginning 07/01/20 and ending 6/30/22, for FY20/21 annual amount not to exceed \$98,000.00 for Liquid Cationic Polymer (Emulsion).

APPROVED AS TO PURCHASING:

Joyce A. McClane  
Purchasing Manager

APPROVED AS TO FINANCE:

Amanda Trujillo  
Acting Chief Financial Officer

APPROVED AS TO FORM:

Angela Wheeler, Chief Legal Officer

Clyde Edwards, City Administrator

CITY COUNCIL:

Monica Galloway, Council President



CITY OF FLINT

RESOLUTION STAFF REVIEW FORM

TODAY'S DATE: 06/01/2020

BID/PROPOSAL# P21-505

AGENDA ITEM TITLE: LIQUID CATIONIC POLYMER (EMULSION)

PREPARED BY Don Lewis (DPW)
(Please type name and Department)

VENDOR NAME: Polydyne Inc.

BACKGROUND/SUMMARY OF PROPOSED ACTION:

The Water Pollution Control Facility operates a sludge dewatering process as part of its solids disposal program. Liquid Emulsion type cationic polymer is required to dewater sludge prior to transport to landfill. Solids disposal is necessary to operate the plant and fulfill the requirements of WPC's National Pollution Discharge Elimination System (NPDES) permit.

FINANCIAL IMPLICATIONS: NA

BUDGETED EXPENDITURE? YES [X] NO [ ] IF NO, PLEASE EXPLAIN:

Table with 5 columns: Dept., Name of Account, Account Number, Grant Code, Amount. Row 1: DPW, Polydyne Inc., 590-550.100-740.500, \$98,000.00 (min. 4500 gal. 1.140 lb.) (less than 4500 gal or totes 1.180 lb.). Row 2: FY19/20 GRAND TOTAL

PRE-ENCUMBERED? YES [X] NO [ ] REQUISITION NO: 200002923



CITY OF FLINT

ACCOUNTING APPROVAL: \_\_\_\_\_ Date: \_\_\_\_\_

WILL YOUR DEPARTMENT NEED A CONTRACT? YES  NO   
(If yes, please indicate how many years for the contract) YEARS

WHEN APPLICABLE, IF MORE THAN ONE (1) YEAR, PLEASE ESTIMATE TOTAL AMOUNT FOR EACH BUDGET YEAR: (This will depend on the term of the bid proposal)

BUDGET YEAR 1 \$98,000.00

BUDGET YEAR 2 \$102,900.00

BUDGET YEAR 3

OTHER IMPLICATIONS (i.e., collective bargaining): NA

STAFF RECOMMENDATION: (PLEASE SELECT):  APPROVED  NOT APPROVED

DEPARTMENT HEAD SIGNATURE: Jeannette M. Best WPC Manager  
(PLEASE TYPE NAME, TITLE)



# CITY OF FLINT

## Department of Purchases & Supplies

Sheldon A. Neeley  
Mayor

May 22, 2020

**TO:** Krystal Wallace  
Jeanette Best  
John Florshinger

**FROM:** Joyce A. McClane  
Purchasing Manager

**SUBJECT:** SEALED BIDS

Attached is one (1) sealed bid that was received for **PROPOSAL #21000505- WPC-LIQUID CATIONIC FOR GRAVITY BELT THICKENER**. Enclosed are copies for your file. **Bid Due Date: 5/06/20. Enclosed is a spreadsheet.**

Your staff review and recommendation form is needed as soon as possible. Please use the new fillable form. This form is to be used for your staff review.

A staff review must be completed for **ALL Bids/Proposals**. Please let me know if you need a copy of the fillable form.

This project has been identified that multiple departments use this item. Please get with those departments to determine the total usage and the amount that needs to go to Council for approval. This proposal is good for 2 years.

**Please note:** If your project is being funded by any grants issued by the federal government, you must go to: <https://www.dol.gov/ofccp/regs/compliance/preaward/debarlist.htm> to ensure that the selected vendor has not been debarred.

**PLEASE NOTE:**

Results may be viewed next business day online EXCEPT when a bid is under review. The bidders/public will only see the names of the bidders that submitted a bid, not their cost. This will protect the bidders cost in case there is a re-bid.



**CITY OF FLINT PROPOSAL NO.21000505**

**SUPPLY LIQUID CATIONIC POLYMER FOR GRAVITY BELT  
THICKENER @ WATER POLLUTION CONTROL**

On Tuesday, March 10, 2020, Governor Gretchen Whitmer declared a State of Emergency after two individuals were confirmed testing presumptively positive for COVID-19. On Thursday, March 12, 2020, Mayor Sheldon A. Neeley declared a local State of Emergency to exist in the City of Flint as a result of the threat of COVID-19. On Sunday, March 15, 2020, effective March 17, 2020, Mayor Neeley, based on the COVID-19 public health threat, closed City Hall to the public. Residents were asked to take precautionary measures. On March 22, 2020, Mayor Neeley asked residents to participate in a voluntary shelter in place. On March 23, 2020, the City Council approved the continuation of the declaration of a State of Emergency.

Based on the White House guidelines issued on March 16, 2020, and continued on March 30, 2020, for an additional 30 days, it is recommended that people not gather in groups larger than 10 people in order to "flatten" the curve and slow the spread of the virus. On March 24, 2020, Governor Whitmer instituted Executive Order 2020-21, a temporary requirement to suspend activities that are not necessary to sustain or protect life, prohibiting "in-person" work with exceptions for essential and critical infrastructure workers.

**FOR THE TIME BEING,  
BIDS WILL ONLY BE ACCEPTED BY MAIL**

Please note: All detailed bids received after 1:00 PM (EST) of the due date will not be considered. Bids must be in a sealed envelope clearly identifying the proposal title and number. Faxed bids are not accepted.

**THIS PAGE INTENTIONALLY LEFT BLANK**



**CITY OF FLINT**  
**FINANCE DEPARTMENT**  
**DIVISION OF PURCHASES AND SUPPLIES**  
City Hall, 1101 S. Saginaw Street, Room #203 – Flint, Michigan 48502  
(810) 766-7340 [www.cityofflint.com](http://www.cityofflint.com)

**INVITATION TO BID**

**OWNER/RETURN TO:**

THE CITY OF FLINT  
FINANCE DEPARTMENT – DIVISION OF PURCHASES AND SUPPLIES  
1101 S. SAGINAW ST., ROOM 203, 2nd FLOOR  
FLINT, MI 48502

**PROPOSAL NO: 21000505**

**SCOPE OF WORK:**

The City of Flint, Finance Department of Purchases & Supplies, is soliciting sealed bids for providing:

**SUPPLY LIQUID CATIONIC POLYMER FOR GRAVITY BELTTHICKENER @ WATER POLLUTION CONTROL**

Per the attached additional requirements.

If your firm is interested in providing the requested services, please submit one (1) original and one (1) printed copy of your detailed bid to the City of Flint, Finance Department of Purchases and Supplies, 1101 S. Saginaw St., Room 203, Flint, MI, 48502, by **May 6, 2020 at 1:00 PM (EST)**. Please note: all detailed bids received after 1:00 PM (EST) will not be considered. Bids must be in a sealed envelope clearly identifying the proposal and number. Faxed bids are not accepted.

The City reserves the right to waive any irregularities and accept or reject any or all proposals submitted. The City is an equal opportunity employer.

All additional proposal documents, requirements, addendums, specifications, and plans/drawings (if utilized) are available on the Purchasing page of the City of Flint's web site at <https://www.cityofflint.com/finance/purchasing/bids-2/> under "open bids" and the specific bid or proposal number assigned to this notice.

New vendors should complete and submit a vendor application, IRS W-9 Form, and ONLY a Vendor ACH Payment Authorization Form if awarded bid with the City of Flint. Links to these forms are available at <https://www.cityofflint.com/finance/accounts-payable-department/>

Results may be viewed next business day online EXCEPT when a bid is under review. The bidders/public will only see the names of the bidders that submitted a bid, not their cost. This will protect the bidders cost in case there is a re-bid. <https://www.cityofflint.com/finance/purchasing/results/> under "bid results".

Any questions regarding the proposal process may be directed to Joyce McClane in writing by no later than **April 27, 2020** before 12:00 PM to [jmcclane@cityofflint.com](mailto:jmcclane@cityofflint.com).

The City of Flint may hold proposals for a period of 120 days from opening, for the purpose of reviewing the results and investigating the qualifications of proposal prior to making an award.

The bidder acknowledges that by signing this document that he/she is duly authorized to make said offer on behalf of the company he/she represents and that said bid is genuine and not sham or collusive and not made in the interests or on behalf of any person not therein named, and that he/she and said bidder have not directly induced or solicited any other person(s) or corporation to refrain from responding to this solicitation and that he/she and said bidder have not in any manner sought by collusion to secure to himself/herself and said bidder any advantage over any other bidder.

Sincerely,

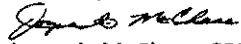

Joyce A. McClane, CPPB  
Purchasing Manager

## **INSTRUCTIONS TO VENDORS**

- 1) **PRE-BID INFORMATION AND QUESTIONS:** Each bid that is timely received will be evaluated on its merit and completeness of all requested information. In preparing bids, Bidders are advised to rely only upon the contents of this Request for Proposals (RFP) and accompanying documents and any written clarifications or addenda issued by the City of Flint. If a Bidder finds a discrepancy, error or omission in the RFP package, or requires any written addendum thereto, the Bidder is requested to notify the Purchasing contact noted on the cover of this RFP, so that written clarification may be sent to all prospective Bidders. **THE CITY OF FLINT IS NOT RESPONSIBLE FOR ANY ORAL INSTRUCTIONS.** All questions must be submitted in writing to the Finance Department of Purchases and Supplies before any pre-bid deadline (if specified) or at least one (1) week prior to the proposal opening date indicated on the front of this document.
  
- 2) **RFP MODIFICATIONS:** The City of Flint has the right to correct, modify or cancel the RFP, in whole or in part, or to reject any Bid, in whole or in part, within the discretion of the City of Flint, or their designee. If any such changes are made, all known recipients of the RFP will be sent a copy of such changes. If any changes are made to this RFP document by any party other than the City of Flint, the original document in the City of Flint's files takes precedence.
  
- 3) **PROPOSAL SUBMISSION:**
  - a) The Bidder must include the following items, or the proposal may be deemed non-responsive:
    - i) All forms contained in this RFP, fully completed.
  
  - b) Bids must be submitted to the Finance Department of Purchases and Supplies, City of Flint, 1101 S. Saginaw Street, Room 203, Flint, Michigan 48502 by the date and time indicated as the deadline. The Purchasing Department time stamp will determine the official receipt time. It is each Bidder's responsibility to insure that their proposal is time stamped by the Purchasing Department by the deadline. This responsibility rests entirely with the Bidder, regardless of delays resulting from postal handling or for any other reasons. Proposals will be accepted at any time during the normal course of business only, said hours being 8:00 a.m. to 5:00 p.m. local time, Monday through Friday, legal holidays as exception.
  
  - c) Bids must be enclosed in a sealed, non-transparent envelope, box or package, and clearly marked on the outside with the following: RFP Title, RFP Number, Deadline and Bidder's name.
  
  - d) Submission of a bid establishes a conclusive presumption that the Bidder is thoroughly familiar with the Request for Proposals (RFP), and that the Contractor understands and agrees to abide by each and all of the stipulations and requirements contained therein.
  
  - e) All prices and notations must be typed or printed in ink. No erasures are permitted. Mistakes may be crossed out and corrections must be initialed in ink by the person(s) signing the bid.
  
  - f) Proposals sent by email, facsimile, or other electronic means will not be considered unless specifically authorized in this RFP.

- g) All costs incurred in the preparation and presentation of the bid are the Bidder's sole responsibility; no pre-bid costs will be reimbursed to any Bidder. All documentation submitted with the proposal will become the property of the City of Flint.
  - h) Proposals must be held firm for a minimum of 120 days.
- 4) **EXCEPTIONS:** Bidder shall clearly identify any proposed deviations from the Terms or Scope in the Request for Proposals. Each exception must be clearly defined and referenced to the proper paragraph in this RFP. The exception shall include, at a minimum, the proposed substitute language and opinion as to why the suggested substitution will provide equivalent or better service and performance. If no exceptions are noted in the bid, the City of Flint will assume complete conformance with this specification and the successful Bidder will be required to perform accordingly. Bids not meeting all requirements may be rejected.
  - 5) **DUPLICATE BIDS:** No more than one (1) bid from any Bidder including its subsidiaries, affiliated companies and franchises will be considered by the City of Flint. In the event multiple proposals are submitted in violation of this provision, the City will have the right to determine which bid will be considered or, at its sole option, reject all such multiple proposals.
  - 6) **WITHDRAWAL:** Bids may only be withdrawn by written notice prior to the date and time set for the opening of bids. No bid may be withdrawn after the deadline for submission.
  - 7) **REJECTION/GOOD STANDING:** The City of Flint reserves the right to reject any or all bids, or to accept or reject any bid in part, and to waive any minor informality or irregularity in bids received if it is determined by the City of Flint, or their designee, that the best interest of the City will be served by doing so. No bid will be considered from any person, firm or corporation in arrears or in default to the City on any contract, debt, taxes or other obligation, or if the Bidder is debarred by the City of Flint from consideration for a contract award pursuant to Section 18-21.5 (d) of Article IV of the "Purchasing Ordinance of the City of Flint".
  - 8) **PROCUREMENT POLICY:** Procurement for the City of Flint will be handled in a manner providing fair opportunity to all businesses. This will be accomplished without abrogation or sacrifice of quality and as determined to be in the best interest of the City. The City of Flint and their officials have the vested authority to execute a contract, subject to City Council and Mayoral approval where required.
  - 9) **BID SIGNATURES:** Bids must be signed by an authorized official of the Bidder. Each signature represents binding commitment upon the Bidder to provide the goods and/or services offered to the City of Flint if the Bidder is determined to be the lowest Responsive and Responsible Bidder.
  - 10) **CONTRACT AWARD/SPLIT AWARDS:** The City of Flint reserves the right to award by item, group of items, or total bid. The Bidder to whom the award is made will be notified at the earliest possible date. Tentative acceptance of the bid, intent to recommend award of a contract and actual award of the contract will be provided by written notice sent to the Bidder at the address designated in the bid if a separate Agreement is required to be executed. After a final award of the Agreement by the City of Flint, the Contractor/Vendor must execute and perform said Agreement. All proposals must be firm for at least 120 days from the due date of the proposal. If, for any reason, a contract is not executed with the selected Bidder within 14 days after notice of recommendation for award, then the City may recommend the next lowest responsive and responsible Bidder.

- 11) **NO RFP RESPONSE:** Bidders who receive this RFP but who do not submit a bid should return this RFP package stating "No Bid" and are encouraged to list the reason(s) for not responding. Failure to return this form may result in removal of the Bidder's name from all future lists.
- 12) **FREEDOM OF INFORMATION ACT (FOIA) REQUIREMENTS:** Bids are subject to public disclosure after the deadline for submission in accordance with state law.
- 13) **ARBITRATION:** Contractor agrees that for all claims, disputes, and other matters arising out of or relating to this agreement, Contractor must request the City's consent to arbitrate within 30 days from the date the Contractor knows or should have known the facts giving rise to the claim, dispute or question.
  - (a) Notice of a request for arbitration must be submitted in writing by certified mail or personal service upon the Chief Legal Officer.
  - (b) Within 60 days from the date a request for arbitration is received by the City, the City shall inform Contractor whether it agrees to arbitrate. If the City does not consent, Contractor may proceed with an action in a court of competent jurisdiction within the State of Michigan. If the City does consent, then within 30 days of the consent each party shall submit to the other the name of one person to serve as an arbitrator. The two arbitrators together shall then select a third person, the three together shall then serve as a panel in all proceedings. Any unanimous decision of the three arbitrators shall be a final binding decision. The City's failure to respond to a timely, conforming request for arbitration is deemed consent to arbitration.
  - (c) The costs of the arbitration shall be split and borne equally between the parties and such costs are not subject to shifting by the arbitrator.
  - (d) Contractor's failure to comply with any portion (including timeliness) of this provision shall be deemed a permanent waiver and forfeiture of the claim, dispute, or question.
  - (e) This provision shall survive the expiration or termination of this Agreement in perpetuity.
- 14) **BID HOLD:** The City of Flint may hold bids for a period of one hundred twenty (120) days from opening, for the purpose of reviewing the results and investigating the qualifications of bidders prior to making an award.
- 15) **NONCOMPLIANCE:** Failure to deliver in accordance with specifications will be cause for the City of Flint and they may cancel the contract or any part thereof and purchase on the open market, charging any additional cost to the Contractor/Vendor.
- 16) **DISCLAIMER OF CONTRACTUAL RELATIONSHIP:** Nothing contained in these documents shall create any contractual relationship between the City and any Subcontractor or Sub-subcontractor.
- 17) **ERRORS AND OMISSIONS:** Bidder is not permitted to take advantage of any obvious errors or omissions in specifications.

- 18) **INTERPRETATION:** In the event that any provision contained herein shall be determined by a court of competent jurisdiction or an appropriate administrative tribunal to be contrary to the provision of law or to be unenforceable for any reason, then, to the extent necessary and possible to render the remainder of this Agreement enforceable, such provision may be modified or severed by such court or administrative tribunal having jurisdiction over this Agreement and the interpretation thereof, or the parties hereto, so as to, as nearly as possible, carry out the intention of the parties hereto, considering the purpose of the entire Agreement in relation to such provision.
- 19) **LAWS AND ORDINANCES:** The Bidder shall obey and abide by all of the laws, rules and regulations of the Federal Government, State of Michigan, Genesee County and the City of Flint, applicable to the performance of this Agreement, including, but not limited to, labor laws, and laws regulating or applying to public improvement, local government, and its operational requirements.
- 20) **LOCAL PREFERENCE:** Contractors/bidders located within the corporate city limits of Flint, Michigan may be given a seven percent (7%) competitive price advantage. Additionally, if the lowest responsible bidder is not located within the limits of the City of Flint, but is located within the County of Genesee, and said bidder does not exceed the bid of the lowest non-local bidder by more than three and one-half percent (3-1/2%), then said lowest Genesee County bidder may be determined to be the lowest responsible bidder, and make the award to such Genesee County bidder accordingly, subject to the approval of the City Council. If the lowest non-local bidder does not exceed that of any Proposers/bidders by (7%) inside the City of Flint or (3-1/2%) inside the County of Genesee, then the Purchasing Director shall be allowed to request that the lowest local vendor match the price offered by the lowest non-local vendor.
- 21) **MATERIAL WORKMANSHIP AND STANDARDS OF PERFORMANCE:** The Bidder agrees to exercise independent judgment and to complete performance under this Agreement in accordance with sound professional practices. In entering into this Agreement, the City is relying upon the professional reputation, experience, certification and ability of the Bidder by her/him/themselves or by others employed by her/him/them and working under their direction and control. The continued effectiveness of this Agreement during its term or any renewal term shall be contingent, in part, upon the Bidder maintaining her/his/their operating qualifications in accordance with the requirements of federal, state and local laws. All materials furnished must be new, of latest model and standard first grade quality, or best workmanship and design, unless otherwise expressly specified. Bidder, if required, must furnish satisfactory evidence of quality materials; offers of experimental or unproven equipment may be disregarded.
- 22) **MODIFICATIONS/CHANGES:** Any modification to this agreement must be in writing and signed by the authorized employee, officer, board or council representative authorized to make such modifications pursuant to the State law and local ordinances.
- 23) **NON-COLLUSION:** The Bidder acknowledges that by signing this document that she/he/they is/are duly authorized to make said offer on behalf of the company she/he/they represent(s) and that said bid is genuine and not sham or collusive and not made in the interests or on behalf of any person not therein named, and that she/he/they and said bidder have not directly induced or solicited any other person(s) or corporation to refrain from responding to this solicitation and that she/he/they and said bidder have not in any manner sought by collusion to secure to themselves and said bidder any advantage over any other bidder.

- 24) **NON-DISCRIMINATION:** Pursuant to the requirements of 1976 P.A. 453 (Michigan Civil Rights Act) and 1976 P.A. 220 (Michigan Handicapped Rights Act), the local unit and its agent agree not to discriminate against any employee or applicant for employment with respect to hire, tenure, terms, conditions, or privileges of employment or a matter directly or indirectly related to employment because of race, color, religion, national origin, age, sex, height, weight, marital status or because of a handicap that is unrelated to the person's ability to perform the duties of nondiscrimination provision identical to this provision and binding upon any and all contractors and subcontractors. A breach of this covenant shall be regarded as a material breach of this contract.
- 25) **SUBCONTRACTING:** No subcontract work shall be started prior to the written approval of the subcontractor by the City. The City reserves the right to accept or reject any subcontractor.
- 26) **UNION COMPLIANCE:** Bidder agrees to comply with all regulations and requirements of any national or local union(s) that may have jurisdiction over any of the materials, facilities, services or personnel to be furnished by the City.
- 27) **WAIVER:** Failure of the City to insist upon strict compliance with any of the terms, covenants or conditions of this Agreement shall not be deemed a waiver of that term, covenant or condition or of any other term, covenant or condition. Any waiver or relinquishment of any right or power hereunder at any one or more times shall not be deemed a waiver or relinquishment of that right or power at any other time.
- 28) **CITY INCOME TAX WITHHOLDING:** Contractor and any subcontractor engaged in this contract shall withhold from each payment to his employees the City income tax on all of their compensation subject to tax, after giving effect to exemptions, as follows:
- a) **Residents of the City:**  
At a rate equal to 1% of all compensation paid to the employee who is a resident of the City of Flint.
  - b) **Non-residents:**  
At a rate equal to 1/2% of the compensation paid to the employee for work done or services performed in the City of Flint.
- These taxes shall be held in trust and paid over to the City of Flint in accordance with City ordinances and State law. Any failure to do so shall constitute a substantial and material breach of this contract.
- 29) **CONTRACT DOCUMENTS:** The invitation for proposal, instructions to proposal, proposal, affidavit, addenda (if any), statement of Bidder's qualifications (when required), general conditions, special conditions, performance bond, labor and material payment bond, insurance certificates, technical specifications, and drawings, together with this agreement, form the contract, and they are as fully a part of the contract as if attached hereto or repeated herein.
- 30) **DISCLAIMER OF CONTRACTUAL RELATIONSHIP WITH SUBCONTRACTORS:** Nothing contained in the Contract Documents shall create any contractual relationship between the City and any Subcontractor or Sub-subcontractor.
- 31) **EFFECTIVE DATE:** Any agreement between the City and the Bidder shall be effective upon the date that it is executed by all parties hereto.

- 32) **FORCE MAJURE:** Neither party shall be responsible for damages or delays caused by Force Majeure nor other events beyond the control of the other party and which could not reasonably have anticipated the control of the other party and which could not reasonably have been anticipated or prevented. For purposes of this Agreement, Force Majeure includes, but is not limited to, adverse weather conditions, floods, epidemics, war, riot, strikes, lockouts, and other industrial disturbances; unknown site conditions, accidents, sabotage, fire, and acts of God. Should Force Majeure occur, the parties shall mutually agree on the terms and conditions upon which the services may continue.
- 33) **INDEMNIFICATION:** To the fullest extent permitted by law, Bidder agrees to defend, pay on behalf of, indemnify, and hold harmless the City of Flint, its elected and appointed officials, employees and volunteers and others working on behalf of the City of Flint, including the Project Manager, against any and all claims, demands, suits, or losses, including all costs connected therewith, and for any damages which may be asserted, claimed, or recovered against or from the City of Flint, its elected and appointed officials, employees, volunteers or others working on behalf of the City of Flint, by reason of personal injury, including bodily injury or death and/or property damage, including loss of use thereof, which may arise as a result of Bidder's acts, omissions, faults, and negligence or that of any of his employees, agents, and representatives in connection with the performance of this contract. Should the Bidder fail to indemnify the City in the above-mentioned circumstances, the City may exercise its option to deduct the cost that it incurs from the contract price forthwith. *These provisions shall survive the termination or expiration of any agreement entered into as a result of this request.*
- 34) **INDEPENDENT CONTRACTOR:** No provision of this contract shall be construed as creating an employer-employee relationship. It is hereby expressly understood and agreed that Bidder is an "independent contractor" as that phrase has been defined and interpreted by the courts of the State of Michigan and, as such, Bidder is not entitled to any benefits not otherwise specified herein.
- 35) **NO THIRD-PARTY BENEFICIARY:** No contractor, subcontractor, mechanic, material man, laborer, vendor, or other person dealing with the principal Contractor shall be, nor shall any of them be deemed to be, third-party beneficiaries of this contract, but each such person shall be deemed to have agreed (a) that they shall look to the principal Contractor as their sole source of recovery if not paid, and (b) except as otherwise agreed to by the principal Contractor and any such person in writing, they may not enter any claim or bring any such action against the City under any circumstances. Except as provided by law, or as otherwise agreed to in writing between the City and such person, each such person shall be deemed to have waived in writing all rights to seek redress from the City under any circumstances whatsoever.
- 36) **NON-ASSIGNABILITY:** Contractor shall not assign or transfer any interest in this contract without the prior written consent of the City provided, however, that claims for money due or to become due to Contractor from the City under this contract may be assigned to a bank, trust company, or other financial institution without such approval. Notice of any such assignment or transfer shall be furnished promptly to the City.
- 37) **NON-DISCLOSURE/CONFIDENTIALITY:** Contractor agrees that the documents identified herein as the contract documents are confidential information intended for the sole use of the City and that Contractor will not disclose any such information, or in any other way make such documents public, without the express written approval of the City or the order of the court of appropriate jurisdiction or as required by the laws of the State of Michigan.



- 38) **RECORDS PROPERTY OF CITY:** All documents, information, reports and the like prepared or generated by Contractor as a result of this contract shall become the sole property of the City of Flint.
- 39) **SEVERABILITY:** In the event that any provision contained herein shall be determined by a court or administrative tribunal to be contrary to a provision of state or federal law or to be unenforceable for any reason, then, to the extent necessary and possible to render the remainder of this Agreement enforceable, such provision may be modified or severed by such court or administrative tribunal so as to, as nearly as possible, carry out the intention of the parties hereto, considering the purpose of the entire Agreement in relation to such provision. The invalidation of one or more terms of this contract shall not affect the validity of the remaining terms.
- 40) **TERMINATION:** This contract may be terminated by either party hereto by submitting a notice of termination to the other party. Such notice shall be in writing and shall be effective 30 days from the date it is submitted unless otherwise agreed to by the parties hereto. Contractor, upon receiving such notice and prorated payment upon termination of this contract shall give to the City all pertinent records, data, and information created up to the date of termination to which the City, under the terms of this contract, is entitled.
- 41) **TIME PERFORMANCE:** Contractor's services shall commence immediately upon receipt of the notice to proceed and shall be carried out forthwith and without reasonable delay.
- 42) **EVALUATION OF PROPOSAL:** In the City's evaluation of proposals, at minimum: cost, serviceability, financial stability, and all requirements set forth in this document shall be considered as selection and award criteria unless otherwise specified.
- 43) **PREVAILING WAGE:** When applicable, all work for state and federal funded projects must meet Davis-Bacon Act requirements and full prevailing wage. Information on Davis-Bacon reporting and requirements, including payroll reporting, can be found at: <https://www.dol.gov/whd/govcontracts/dbra.htm>
- 44) **BONDS – PAYMENT AND PERFORMANCE:** The City of Flint may request that before any contract, exceeding \$50,000.00 for the construction, alteration, or repair of any public building or public work or improvement of the state or a county, city, village, township, school district, public educational institution, other political subdivision, public authority, or public agency hereinafter referred to as the "governmental unit", is awarded, the proposed contractor, hereinafter referred to as the "principal contractor", shall furnish at his or her own cost to the governmental unit a performance bond and a payment bond which shall become binding upon the award of the contract to the principal contractor. However, if the principal contractor is a common carrier as defined in section 3 of Act No. 300 of the Public Acts of 1909, as amended, being section 462.3 of the Michigan Compiled Laws, or the designated operator of a state subsidized railroad, the principal contractor may provide an irrevocable letter of credit from a state or national bank or a state or federally chartered savings and loan association instead of the bonds. Neither the invitation for bids, nor any person acting, or purporting to act, on behalf of the governmental unit shall require that the bonds be furnished by a particular bank or surety company, or through a particular agent or broker, or through a bank, company, agent, or broker in any particular locality.

**Payment Bond**

The payment bond shall be in a minimum amount of 25% of the contract amount solely for the protection of claimants, as defined in section 6, supplying labor or materials to the principal contractor or his subcontractors in the protection of the work provided for in the contract. Payment bond shall be set by the City of Flint and shall be agreed upon by parties of any contract.

**Performance Bond**

The performance bond shall be in a minimum amount of 25% of the contract amount, conditioned upon the faithful performance of the contract in accordance with the plans, specifications and terms thereof. The bond shall be solely for the protection of the governmental unit awarding the contract. Performance bond shall be set by the City of Flint and shall agree upon by parties of any contract.

**45) INSURANCE/WORKERS COMPENSATION:** Contractor shall not commence work under this contract until he has procured and provided evidence of the insurance required under this section. All coverage shall be obtained from insurance companies licensed and authorized to do business in the State of Michigan unless otherwise approved by the City's Risk Manager. Policies shall be reviewed by the City's Risk Manager for completeness and limits of coverage. All coverage shall be with insurance carriers acceptable to the City of Flint. Contractor shall maintain the following insurance coverage for the duration of the contract.

(a) Commercial General Liability coverage of not less than one million dollars (\$1,000,000) combined single limit with the City of Flint, and including all elected and appointed officials, all employees and volunteers, all boards, commissions and/or authorities and their board members, employees and volunteers, named as "Additional Insured." This coverage shall be written on an ISO occurrence basis form and shall include: Bodily Injury, Personal Injury, Property Damage, Contractual Liability, Products and Completed Operations, Independent Contractors; Broad Form Commercial General Liability Endorsement, (XCU) Exclusions deleted and a per contract aggregate coverage. This coverage shall be primary to the Additional Insured, and not contributing with any other insurance or similar protection available to the Additional Insured, whether said other available coverage be primary, contributing, or excess.

(b) Workers Compensation Insurance in accordance with Michigan statutory requirements, including Employers Liability coverage.

(c) Commercial Automobile Insurance in the amount of not less than \$1,000,000 combined single limit per accident with the City of Flint, and including all elected and appointed officials, all employees and volunteers, all boards, commissions and/or authorities and their board members, employees and volunteers, named as "Additional Insured." This coverage shall be written on ISO business auto forms covering Automobile Liability, code "any auto."

(d) Professional Liability - Errors and Omissions. All projects involving the use of Architects, civil engineers, landscape design specialists, and other professional services must provide the City of Flint with evidence of Professional Liability coverage in an amount not less than one million dollars (\$1,000,000) Evidence of this coverage must be provided for a minimum of three years after project completion. Any deductibles or self-insured retention must be declared to and approved by the City. In addition, the total dollar value of all claims paid out on the policy shall be declared. At the option of the City, either the

insurer shall reduce or eliminate such deductibles or self-insured retention with respect to the City, its officials, employees, agents and volunteers; or Contractor shall procure a bond guaranteeing payment of losses and related investigation, claim, administration, and defense expenses.

Contractor shall furnish the City with one certificate of insurance for all coverage requested with original endorsements for those policies requiring the Additional Insured. PJI certificates of insurance must provide the City of Flint with not less than 30-days advance written notice in the event of cancellation, non-payment of premium, non-renewal, or any material change in policy coverage. In addition, the wording "Endeavor to" and "but failure to mail such notice shall impose no obligation or liability of any kind upon the company, its agents or representatives" must be removed from the standard ACORD cancellation statement. These certificates must identify the City of Flint as the "Certificate Holder." Contractor must provide, upon request, certified copies of all insurance policies. If any of the above policies are due to expire during the term of this contract, Contractor shall deliver renewal certificates to 1101 S. Saginaw St., Room 203, Flint, MI 48502 Phone: (810)766-7340 Fax: (810) 766-7240 and copies of the new policies to the City of Flint at least ten days prior to the expiration date. Contractor shall ensure that all subcontractors utilized obtain and maintain all insurance coverage required by this provision.

**LEAVE BLANK INTENTIONALLY**

## **REQUIREMENTS / TABULATION**

**Water Pollution  
Control**

**G-4652 Beecher Rd.  
Flint, MI 48632**

### **FY 20/21 WPC POLYMER – GRAVITY BELT THICKENER EMULSION**

FURNISH AS REQUESTED FOR THE PERIOD OF **07/01/2020 TO 06/30/2022.**

QUANTITIES (DOLLAR AMOUNTS) ARE NOT GUARANTEED.

SUPPLY LIQUID CATIONIC POLYMER ON AN AS-NEEDED BASIS AS OUTLINED IN THE ATTACHED SPECIFICATIONS.

PRICING PER PROPOSAL #21000505

FOR FURTHER INFORMATION, PLEASE CONTACT JEANNETTE BEST, WPC SUPERVISOR OR PLANT OPERATIONS AT 810-766-7210 EXTENSION 3628.

*Only the specifier has the responsibility and judgment for determining whether a proposed substitution is an "or equal or exceeding" specification. Mfg., model #, and supporting documentation of specifications for alternates must be provided.*

**PROPOSAL**

Bid of Polydyne Inc. (hereinafter called **Bidder**), organized and existing under the laws of the State of Delaware doing business as Polydyne Inc. ('Corporation', 'Partnership', 'Individual' as applicable) to the City of Flint, Michigan (hereinafter called **Owner**).

In compliance with the **Owner's** Advertisement for Bids, **Bidder** hereby proposes to supply Liquid Emulsion Type Cationic Polymer, in strict accordance with the **Bid Specifications**, at the price stated below, using the **Carrier(s)** stated below.

By submission of this bid each **Bidder** certifies (in case of a joint bid, each party thereto certifies as to his own organization) that this bid has been arrived at independently and without consultation, communication, or agreement with any other bidders or with any competitor.

**Bidder** hereby agrees to supply Liquid Emulsion Type Cationic Polymer for dewatering of wastewater biosolids, using either a belt filter press or a centrifuge, for a **two (2) year period from 07/01/2020 to 06/30/2022** as detailed in the **Bid Specifications**.

**Provide pricing for the product(s) outlined in the Bid Specifications, all products are to be good for their intended use and delivered F.O.B. Destination to G-4652 Beecher Road, Flint, MI, 48532, Filter Press/Centrifuge Building. Provide pricing per the following options:**

- a. 270 gallon (approximately) carboys (totes) at the price of \$ 1.180 per Lb.
- b. Less than 4500 gallons via tanker, each load at the price of \$ 1.180 per Lb.
- c. 4500 gallons via tanker, each load at the price of \$ 1.140 per Lb.

Point of shipment Riceboro, GA Carrier(s) Common Carriers

**Bidder** shall also provide Technical Assistance as needed and detailed in the **Bid Specifications**.

The **Bidder** understands that the **Owner** reserves the right to reject any and all bids and that no guarantee of quantity under this proposal is implied.

Dated and signed this 1st day of May, 2020

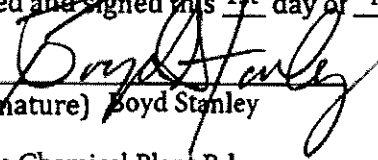
  
(Signature) Boyd Stanley

Vice-President  
(Title)

One Chemical Plant Rd.  
(Address)

Riceboro, GA 31323  
(City, State)

(912) 880-2035  
(Telephone)

(912) 880-2078  
(Fax)

bids@polydyneinc.com / www.polydyneinc.com  
(Email/Website)

**INSTRUCTIONS TO BIDDERS**

## **RECEIPT OF BID**

Sealed bids are invited for the supply of Liquid Emulsion Type Cationic Polymer listed as "Supply Liquid Cationic Polymer" for the City of Flint, Michigan and will be received by the City of Flint, Department of Purchases and Supplies, Room 304, City Hall, 1101 South Saginaw Street, Flint, Michigan 48502, up to **1:00 P.M. local time on May 6, 2020**, at which time they will be opened and publicly read.

**Proposals shall be submitted in duplicate.**

## **RELEASE OF BID SPECIFICATIONS**

**Bid Specifications** may be procured by **Bidders** from the City of Flint website, [cityofflint.com](http://cityofflint.com), or from the Department of Purchases and Supplies, Room 304, City Hall, 1101 South Saginaw, Flint, Michigan 48502.

## **GENERAL CONDITIONS**

### **QUANTITIES**

The quantity of material required will be up to but not limited to 104,500 Lbs. of Emulsion-Type Liquid Cationic Polymer for dewatering of wastewater biosolids, using either a belt filter press or a centrifuge, according to the requirements of the **Owner**. No guarantee of quantity is implied under the terms of this bid. **Bidder** shall have no claim for loss of anticipated profits or any other damages due to any deductions from or additions to these quantities. The **Owner** may chose during the period covered by this purchase order to purchase other types of polymer from the **Bidder** in conjunction with this Purchase Order or from other **Vendors** under a separate Purchase Order as needed.

### **DELIVERIES**

All deliveries shall arrive between the hours of 9 a.m. and 2 p.m. local time, Monday through Friday. All costs incurred by the **Owner** due to the **Carrier's** failure to make delivery between the hours of 9 a.m. and 2 p.m. shall be charged to the **Bidder's** account. The **Owner** reserves the right to schedule deliveries during off hours with no additional cost. Product will be delivered no later than 5 days after the ordered date. The product is to be delivered in bulk tanker truck loads, skid-mounted plastic totes, or carboys of approximately 275 gallons each, unless directed otherwise. Product is to be delivered to the Filter Press/Centrifuge Building. **Owner's** employees will assist the **Carrier** in unloading shipments or connecting to the **Owner's** equipment.

### **CONTRACT DURATION**

The period covered by the proposal shall be **two (2) year** from the date of issuance of a purchase order by the **Owner**, the year being **July 1, 2020 to June 30, 2022**.

### **FAILURE TO DELIVER MATERIAL**

Should the **Bidder** fail to deliver the material specified in the amount ordered, the **Owner** reserves the right to procure such material as has been ordered from other sources, and if the cost of the material purchased is greater than the amount specified under the terms and conditions of the **Bid Specifications**, the difference shall be charged to the **Bidder**.

### **REQUIRED DOCUMENTATION AND SAMPLES**

Upon delivery of each shipment **Bidder** shall provide documentation indicating the following; material identification, Certificate of Analysis, tare weight, net weight, and gross weight. **Owner** reserves the right to refuse any delivery that fails to meet bid specifications or lacks the required documentation.

**Bidder** shall furnish a receipt of materials specifying the number pounds of Liquid Emulsion Cationic Polymer delivered with the supporting weight tickets and the purchase order number as issued by the **Owner**.

**Bidder** shall furnish the **Owner** a copy of the Safety Data Sheet for Liquid Cationic Polymer and any other substances present in the solution prior to initial shipment of materials.

**Carrier** shall have a copy of the Safety Data Sheet for Liquid Cationic Polymer located in the truck cab and provide a copy to the **Owner** with each delivery.



## **BILLING PROCEDURE**

**Bidder** shall submit invoices to: [accountspayable@cityofflint.com](mailto:accountspayable@cityofflint.com)

The City now conducts all business using electronic fund transfers exclusively. Vendors must become enrolled in the City's financial system (Payables) by submitting a form W-9 and ACH, which is available on the City's website or through its Finance Department.

## **SPECIFICATIONS**

### **EQUIPMENT SPECIFICATIONS**

Vendor is responsible for the transportation of the product in the container specified. If totes are ordered, the vendor shall provide the plastic carboys of approximately 275 gallons mounted on a skid designed to fit the **Owner's** equipment for unloading material (standard fork lift).

If bulk tanker quantities are ordered, the Carrier shall have adequate hoses with the proper fittings to enable connection to the Owners storage tanks. The current connectors are 4-inch cam lock types.

**Bidder** shall include the cost of the use of all containers, all freight/handling for all quantities in the bid purchase price.

**Owner** reserves the right to refuse material, at the Vendor's expense, if: the integrity of the equipment or the Vendor's container(s), or tank liner has been compromised, leaks, or is contaminated by previously hauled materials; or the **Carrier** fails to provide required documentation.

### **CHEMICAL SPECIFICATIONS**

The polymer offered must be usable and compatible with the **Owner's** existing polymer storage and feed systems. The system uses and is designed for an emulsion-type polymer fed from a tank or plastic carboy. The plant is currently using Clarifloc CE-2141 successfully.

The product's effectiveness must not be altered significantly by temperature. It must be filtered, and not contain debris or congealed material which could plug piping or pumps.

The product must not adversely affect the **Owner's** polymer feed system, sludge dewatering systems, receiving stream or employee health. The **Bidder** shall be responsible for any adverse consequences due to their product.

The product supplied shall have a shelf life of at least one hundred eighty (180) days in the concentrated form, and at least five (5) days in the diluted form. It must be at least 37% active.

The product and constituents must not be deemed hazardous, and meet the requirements of a non-hazardous material according to the guidelines of the Hazardous Waste Act.

**Owner reserves the right to return to the Bidder, at the Bidder's expense, any material deemed unfit. If material has to be returned on more than three occasions during the Contract term, the Owner reserves the right to bar the vendor from future purchases.**

**Inability to meet the chemical specifications as indicated in the Bid Specifications shall result in the immediate termination of the purchase agreement.**

### **PRE-BID EVALUATION**

**An opportunity will be provided for the Bidder to demonstrate suitable products prior to bid submittal. Initial evaluations will be based on bench (lab) testing, which must be scheduled in advance by contacting the Water Pollution Control Facility at 810-766-7210. Candidate products which appear to offer equivalent or better performance than products currently used, with an economic advantage of at least 10%, may be submitted for full-scale testing. An adequate amount of the product 1 tote (up to 275 gallons) for full-scale testing must be furnished at no charge to the City.**

### **BID SUBMISSION**

**The Bidder may propose one product for consideration. A 2 liter sample shall be submitted for any products not previously used. Bench-scale screening testing shall be run to compare it to current products used. Only products which appear to perform better than current one at the bench level will be deemed worthy of full scale testing. Vendor shall supply the following information as part of the bid proposal:**

- a) Detailed physical and chemical specifications
- b) Safety Data Sheet
- c) Detailed Certificate of Analysis
- d) Product literature
- e) Detailed solution preparation, usage and handling information
- f) Price per pound F.O.B. Destination, Flint Water Pollution Control Facilities

### **PERFORMANCE EVALUATION**

Final performance evaluation selection criteria will be cost per dry ton of dewatered solids and capture rates. Final performance testing will be using a Belt Filter Press or Centrifuge operated by the City of Flint Water Pollution Control Operations staff, with equipment settings and direction given by vendor representatives. The machine will be operated so as to generate maximum dry tons of solids, with filtrate water of no more than 0.60% dry solids content. Any test runs in which the filtrate exceeds this level will not be counted. Test results will be available to **Bidders** upon written request.

The City of Flint may evaluate vapors released by the product for substances that may produce objectionable odors or cause harm to employees. Product may be rejected if it is found to release such odors or harmful vapors.

### **TECHNICAL ASSISTANCE**

The **Bidder** shall provide technical assistance as needed.  
There will be no additional cost to the Owners for such technical assistance.

**THIS PAGE MUST BE COMPLETED AND INCLUDED WITH SUBMITTAL:**

The undersigned hereby certifies, on behalf of the respondent named in this Certification (the "Respondent"), that the information provided in this offer submitted to the City of Flint is accurate and complete, and that I am duly authorized to submit same. I hereby certify that the Respondent has reviewed all documents and requirements included in this offer and accept its terms and conditions

How long will it take to complete this project? Anticipated completion date is June 30, 2022

Terms: Net 30 Days - No Discounts Dest: Flint, MI Fed. ID#: 34-1810283

CONTRACTOR NAME: Polydyne Inc.

ADDRESS: One Chemical Plant Rd.

CITY/STATE/ZIP: Riceboro, GA 31323

PHONE: (912) 880-2035 FAX: (912) 880-2078

SIGNED:  DATE: 05/01/20

PRINTED: Boyd Stanley TITLE: Vice-President

**\*\*\*Failure to use this bid form shall result in bid disqualification.**

No work on this project shall commence without prior written notice to proceed from the project manager.

**LIST OF REFERENCES: (3) SIMILAR SCOPE OF WORK FROM THE LAST 5 YEARS**

Providing the following contact information enables the City of Flint to contact those accounts as references.

**Reference #1:**

Company/Municipality: Buffalo Sewer Authority  
Contact Person: Alex Emmerson Title: Plant Superintendent  
Address: 90 W. Ferry St.  
City: Buffalo State: NY Zip: 14213  
Telephone: (716) 913-7545 Fax: \_\_\_\_\_  
Email: aemerson@buffalosewer.org  
Type of Project: Supply of Cationic Emulsion Polymer  
Project Timeline (Dates): 04/24/12 - 06/30/20 Budget: \$896,000.00 per year

**Reference #2:**

Company/Municipality: Louisville M.S.D.  
Contact Person: Robin Burch Title: Process Support Engineer  
Address: 4522 Algonquin Parkway  
City: Louisville State: KY Zip: 40211  
Telephone: (502) 372-7646 Fax: \_\_\_\_\_  
Email: robin.burch@louisvillemtd.org  
Type of Project: Supply of Cationic Emulsion Polymer  
Project Timeline (Dates): 05/09/13 - 08/31/20 Budget: \$1,216,000.00 per year

**CITY OF FLINT PROPOSAL NO.21000505 – LIQUID CATIONIC POLYMER FOR GRAVITY BELT THICKENER @ WATER POLLUTION CONTROL**

**Reference #3:**

Company/Municipality: City of Atlanta  
Contact Person: Daniel Sabou Title: Plant Manager  
Address: 2440 Bolton Rd., N.W.  
City: Atlanta State: GA Zip: 30318  
Telephone: (404) 565-8903 Fax: \_\_\_\_\_  
Email: dsabou@atlantaga.gov  
Type of Project: Supply of Cationic Emulsion Polymer  
Project Timeline (Dates): 02/28/14 - 03/04/21 Budget: \$647,325.00 per year

**THE FOLLOWING PAGES MUST BE COMPLETED AND INCLUDED WITH SUBMITTAL IN THE FOLLOWING ORDER.**

**Checklist:**

- Cover Sheet
- Pricing Page
- W-9
- List of References
- Certification Regarding Debarment, Suspension, and Other Responsibility Matters
- Qualifications
- Licenses
- Certificate of Insurance
- City of Flint, Michigan Affidavit

***Failure to provide the following items with your bid shall be cause for rejection of bid as non-responsive and/or non-responsible. It is the responsibility of the bidder to ensure that it has received all addenda and to include signed copies with their bid.***

**Certification Regarding  
Debarment, Suspension, and Other Responsibility Matters**

The prospective participant certifies, to the best of its knowledge and belief, that it and its principals:

- 1) Are not presently or proposed to be debarred or suspended, declared ineligible, or voluntarily excluded from federal, state, or local (hereinafter "public") transactions;
- 2) Have not within a three-year period preceding this Agreement been convicted of or had a civil judgment rendered against them for
  - i. Fraud or commission of a criminal offence in connection with obtaining, attempting to obtain, or performing a public transaction or contract under a public transaction,
  - ii. Violation of federal or state antitrust laws, or
  - iii. Embezzlement, theft, forgery, bribery, falsification or destruction of records, making false statements or receiving stolen property;
- 3) Have not within the preceding three years had a public transaction terminated for cause or default; and
- 4) Are not presently indicted for or otherwise criminally or civilly charged by a public entity with commission of any of the offenses enumerated under the above.

I understand that a false statement on this certification may be grounds for the rejection of this proposal or the termination of the award.

Boyd Stanley, Vice-President

\_\_\_\_\_  
Name and Title of Authorized Representative

Polydyne Inc.

\_\_\_\_\_  
Name of Participant Agency or Firm

  
\_\_\_\_\_  
Signature of Authorized Representative

05/01/20

\_\_\_\_\_  
Date

I am unable to certify to the above statement. Attached is my explanation.



**CITY OF FLINT, MICHIGAN AFFIDAVIT  
AFFIDAVIT FOR INDIVIDUAL**

STATE OF \_\_\_\_\_

S.S.

COUNTY OF \_\_\_\_\_

\_\_\_\_\_ being duly sworn,  
deposes and says that he is the person making the above bid; and that said bid is genuine and not sham or  
collusive, and is not made in the interest of or on behalf of any person not therein named, and that he has not  
directly or indirectly induced or solicited any bidder to put in a sham bid; that he has not directly or indirectly  
induced or solicited any other person or corporation to refrain from bidding, and that he has not in any manner  
sought by collusion to secure himself any advantage over other bidders.

Subscribed and sworn to before me at \_\_\_\_\_, in said County and State,

this \_\_\_\_\_ day of \_\_\_\_\_, A.D. 20\_\_\_\_,

\_\_\_\_\_  
\*Notary Public, \_\_\_\_\_ County, \_\_\_\_\_

My Commission expires \_\_\_\_\_, 20\_\_\_\_

FOR CORPORATION

STATE OF Georgia

S.S.

COUNTY OF Liberty

Boyd Stanley being duly sworn, deposes and says that she/he/they

is Vice-President of Polydyne Inc.  
(Official Title) (Name of Corporation)

a corporation duly organized and doing business under the laws of the State of Delaware the corporation making the within and foregoing bid; that he executed said bid in behalf of said corporation by authority of its Board of Directors; that said bid is genuine and not sham or collusive and is not made in the interests of or on behalf of any person not herein named, and that he has not and said bidder has not directly or indirectly induced or solicited any other person or corporation to refrain from bidding; that he has not and said bidder has not in any manner sought by collusion to secure to himself or to said corporation an advantage over other bidders.

Subscribed and sworn to before me at Riceboro, GA in said County and State,

this 1st day of May, A.D. 2020

*Rebecca Beasley*

My Commission Expires Dec. 17, 2020 Notary Public, Liberty County, Georgia

My Commission expires Dec. 17, 2020



FOR PARTNERSHIP

STATE OF \_\_\_\_\_

S.S.

COUNTY OF \_\_\_\_\_

\_\_\_\_\_ being duly sworn, deposes and says that he is a member of the firm of \_\_\_\_\_, a co-partnership, making the above bid; that he is duly authorized to make said bid on behalf of said co-partnership; that said bid is genuine and not sham of collusive, and is not made in the interest of or on behalf of any person not therein named, and that he has and said bidder has not directly or indirectly induced or solicited any other person or corporation to refrain from bidding, and that he has not and said bidder has not in any manner sought by collusion to secure to himself or to said bidder any advantage over other bidders.

Subscribed and sworn to before me at \_\_\_\_\_, in said County and State,

this \_\_\_\_\_ day of \_\_\_\_\_, A.D. 20 \_\_\_\_\_,

\_\_\_\_\_  
\*Notary Public, \_\_\_\_\_ County, \_\_\_\_\_

My Commission expires \_\_\_\_\_, 20 \_\_\_\_\_

FOR AGENT

STATE OF \_\_\_\_\_

S.S.

COUNTY OF \_\_\_\_\_

\_\_\_\_\_ being duly sworn, deposes and says that he executed the within and foregoing bid in behalf of \_\_\_\_\_, the bidder therein named, he having been theretofore lawfully authorized, as the agent of said bidder, so to do; that said bid is genuine and not sham or collusive and not made in the interests of or on behalf of any person not therein named, and that he has not and said bidder has not directly or indirectly induced or solicited any bidder to put in a sham bid; that he has not and said bidder has not directly or indirectly induced or solicited any other person or corporation to refrain from bidding, and that he has not and said bidder has not in any manner sought by collusion to secure to himself or to said bidder any advantage over other bidders.

Subscribed and sworn to before me at \_\_\_\_\_, in said County and State, this \_\_\_\_\_ day of \_\_\_\_\_, A.D. 20 \_\_\_\_\_,

\_\_\_\_\_  
\*Notary Public, \_\_\_\_\_ County, \_\_\_\_\_

My Commission expires \_\_\_\_\_, 20 \_\_\_\_\_

*NOTE: If executed outside of the State of Michigan, certificate by the Clerk of the Court of Record, authenticating the Notary's Signature and authority should be attached.*

## STATEMENT OF QUALIFICATIONS

**POLYDYNE INC. ("POLYDYNE") is a wholly owned subsidiary of SNF HOLDING COMPANY ("SNFHC"). POLYDYNE is the largest supplier of water-soluble polymers to the municipal market in the United States. In addition to POLYDYNE, SNFHC operates nine manufacturing plants in the United States. We are a fully integrated manufacturing company and produce several of our key raw materials. POLYDYNE is also the only polymer supplier that offers a full range of polymer i.e. powders, emulsion and solutions. Worldwide our company has been in operation for over 25 years.**

**POLYDYNE's exclusive charter is to be the direct marketing organization for all SNFHC produced products, to the municipal market, in the United States, particularly those requiring "Manufacturer Only".**

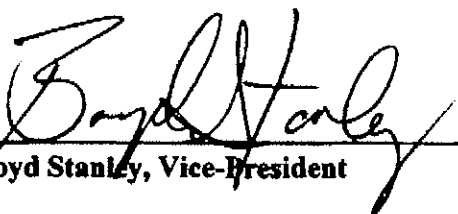
  
\_\_\_\_\_  
**Boyd Stanley, Vice-President**

**05/01/20**

**Date**

## Request for Taxpayer Identification Number and Certification

**Give form to the  
requester. Do not  
send to the IRS.**

Print or type See Specific instructions on page 2.	Name (as shown on your income tax return) <b>Polydyne Inc.</b>	
	Business name, if different from above	
	Check appropriate box: <input type="checkbox"/> Individual/Sole proprietor <input checked="" type="checkbox"/> Corporation <input type="checkbox"/> Partnership <input type="checkbox"/> Limited liability company. Enter the tax classification (D=disregarded entity, C=corporation, P=partnership) ▶ ..... <input type="checkbox"/> Exempt payee <input type="checkbox"/> Other (see instructions) ▶	
	Address (number, street, and apt. or suite no.) <b>One Chemical Plant Rd.</b>	Requester's name and address (optional)
	City, state, and ZIP code <b>Riceboro, GA 31323</b>	
List account number(s) here (optional)		

### Part I Taxpayer Identification Number (TIN)

Enter your TIN in the appropriate box. The TIN provided must match the name given on Line 1 to avoid backup withholding. For individuals, this is your social security number (SSN). However, for a resident alien, sole proprietor, or disregarded entity, see the Part I instructions on page 3. For other entities, it is your employer identification number (EIN). If you do not have a number, see *How to get a TIN* on page 3.

Social security number
:
:
OR
Employer identification number
34 : 1810283

**Note.** If the account is in more than one name, see the chart on page 4 for guidelines on whose number to enter.

### Part II Certification

Under penalties of perjury, I certify that:

1. The number shown on this form is my correct taxpayer identification number (or I am waiting for a number to be issued to me), and
2. I am not subject to backup withholding because: (a) I am exempt from backup withholding, or (b) I have not been notified by the Internal Revenue Service (IRS) that I am subject to backup withholding as a result of a failure to report all interest or dividends, or (c) the IRS has notified me that I am no longer subject to backup withholding, and
3. I am a U.S. citizen or other U.S. person (defined below).

**Certification instructions.** You must cross out item 2 above if you have been notified by the IRS that you are currently subject to backup withholding because you have failed to report all interest and dividends on your tax return. For real estate transactions, item 2 does not apply. For mortgage interest paid, acquisition or abandonment of secured property, cancellation of debt, contributions to an individual retirement arrangement (IRA), and generally, payments other than interest and dividends, you are not required to sign the Certification, but you must provide your correct TIN. See the instructions on page 4.

<b>Sign Here</b>	Signature of U.S. person ▶	Date ▶ 05/01/20
------------------	----------------------------	-----------------

### General Instructions

Section references are to the Internal Revenue Code unless otherwise noted.

#### Purpose of Form

A person who is required to file an information return with the IRS must obtain your correct taxpayer identification number (TIN) to report, for example, income paid to you, real estate transactions, mortgage interest you paid, acquisition or abandonment of secured property, cancellation of debt, or contributions you made to an IRA.

Use Form W-9 only if you are a U.S. person (including a resident alien), to provide your correct TIN to the person requesting it (the requester) and, when applicable, to:

1. Certify that the TIN you are giving is correct (or you are waiting for a number to be issued),
2. Certify that you are not subject to backup withholding, or
3. Claim exemption from backup withholding if you are a U.S. exempt payee. If applicable, you are also certifying that as a U.S. person, your allocable share of any partnership income from a U.S. trade or business is not subject to the withholding tax on foreign partners' share of effectively connected income.

**Note.** If a requester gives you a form other than Form W-9 to request your TIN, you must use the requester's form if it is substantially similar to this Form W-9.

**Definition of a U.S. person.** For federal tax purposes, you are considered a U.S. person if you are:

- An individual who is a U.S. citizen or U.S. resident alien,
- A partnership, corporation, company, or association created or organized in the United States or under the laws of the United States,
- An estate (other than a foreign estate), or
- A domestic trust (as defined in Regulations section 301.7701-7).

**Special rules for partnerships.** Partnerships that conduct a trade or business in the United States are generally required to pay a withholding tax on any foreign partners' share of income from such business. Further, in certain cases where a Form W-9 has not been received, a partnership is required to presume that a partner is a foreign person, and pay the withholding tax. Therefore, if you are a U.S. person that is a partner in a partnership conducting a trade or business in the United States, provide Form W-9 to the partnership to establish your U.S. status and avoid withholding on your share of partnership income.

The person who gives Form W-9 to the partnership for purposes of establishing its U.S. status and avoiding withholding on its allocable share of net income from the partnership conducting a trade or business in the United States is in the following cases:

- The U.S. owner of a disregarded entity and not the entity,

- The U.S. grantor or other owner of a grantor trust and not the trust, and
- The U.S. trust (other than a grantor trust) and not the beneficiaries of the trust.

**Foreign person.** If you are a foreign person, do not use Form W-9. Instead, use the appropriate Form W-8 (see Publication 515, Withholding of Tax on Nonresident Aliens and Foreign Entities).

**Nonresident alien who becomes a resident alien.** Generally, only a nonresident alien individual may use the terms of a tax treaty to reduce or eliminate U.S. tax on certain types of income. However, most tax treaties contain a provision known as a "saving clause." Exceptions specified in the saving clause may permit an exemption from tax to continue for certain types of income even after the payee has otherwise become a U.S. resident alien for tax purposes.

If you are a U.S. resident alien who is relying on an exception contained in the saving clause of a tax treaty to claim an exemption from U.S. tax on certain types of income, you must attach a statement to Form W-9 that specifies the following five items:

1. The treaty country. Generally, this must be the same treaty under which you claimed exemption from tax as a nonresident alien.
2. The treaty article addressing the income.
3. The article number (or location) in the tax treaty that contains the saving clause and its exceptions.
4. The type and amount of income that qualifies for the exemption from tax.
5. Sufficient facts to justify the exemption from tax under the terms of the treaty article.

**Example.** Article 20 of the U.S.-China income tax treaty allows an exemption from tax for scholarship income received by a Chinese student temporarily present in the United States. Under U.S. law, this student will become a resident alien for tax purposes if his or her stay in the United States exceeds 5 calendar years. However, paragraph 2 of the first Protocol to the U.S.-China treaty (dated April 30, 1984) allows the provisions of Article 20 to continue to apply even after the Chinese student becomes a resident alien of the United States. A Chinese student who qualifies for this exception (under paragraph 2 of the first protocol) and is relying on this exception to claim an exemption from tax on his or her scholarship or fellowship income would attach to Form W-9 a statement that includes the information described above to support that exemption.

If you are a nonresident alien or a foreign entity not subject to backup withholding, give the requester the appropriate completed Form W-8.

**What is backup withholding?** Persons making certain payments to you must under certain conditions withhold and pay to the IRS 28% of such payments. This is called "backup withholding." Payments that may be subject to backup withholding include interest, tax-exempt interest, dividends, broker and barter exchange transactions, rents, royalties, nonemployee pay, and certain payments from fishing boat operators. Real estate transactions are not subject to backup withholding.

You will not be subject to backup withholding on payments you receive if you give the requester your correct TIN, make the proper certifications, and report all your taxable interest and dividends on your tax return.

**Payments you receive will be subject to backup withholding if:**

1. You do not furnish your TIN to the requester,
2. You do not certify your TIN when required (see the Part II instructions on page 3 for details),
3. The IRS tells the requester that you furnished an incorrect TIN,

4. The IRS tells you that you are subject to backup withholding because you did not report all your interest and dividends on your tax return (for reportable interest and dividends only), or

5. You do not certify to the requester that you are not subject to backup withholding under 4 above (for reportable interest and dividend accounts opened after 1983 only).

Certain payees and payments are exempt from backup withholding. See the instructions below and the separate instructions for the Requester of Form W-9.

Also see *Special rules for partnerships* on page 1.

## Penalties

**Failure to furnish TIN.** If you fail to furnish your correct TIN to a requester, you are subject to a penalty of \$50 for each such failure unless your failure is due to reasonable cause and not to willful neglect.

**Civil penalty for false information with respect to withholding.** If you make a false statement with no reasonable basis that results in no backup withholding, you are subject to a \$500 penalty.

**Criminal penalty for falsifying information.** Willfully falsifying certifications or affirmations may subject you to criminal penalties including fines and/or imprisonment.

**Misuse of TINs.** If the requester discloses or uses TINs in violation of federal law, the requester may be subject to civil and criminal penalties.

## Specific Instructions

### Name

If you are an individual, you must generally enter the name shown on your income tax return. However, if you have changed your last name, for instance, due to marriage without informing the Social Security Administration of the name change, enter your first name, the last name shown on your social security card, and your new last name.

If the account is in joint names, list first, and then circle, the name of the person or entity whose number you entered in Part I of the form.

**Sole proprietor.** Enter your individual name as shown on your income tax return on the "Name" line. You may enter your business, trade, or "doing business as (DBA)" name on the "Business name" line.

**Limited liability company (LLC).** Check the "Limited liability company" box only and enter the appropriate code for the tax classification ("D" for disregarded entity, "C" for corporation, "P" for partnership) in the space provided.

For a single-member LLC (including a foreign LLC with a domestic owner) that is disregarded as an entity separate from its owner under Regulations section 301.7701-3, enter the owner's name on the "Name" line. Enter the LLC's name on the "Business name" line.

For an LLC classified as a partnership or a corporation, enter the LLC's name on the "Name" line and any business, trade, or DBA name on the "Business name" line.

**Other entities.** Enter your business name as shown on required federal tax documents on the "Name" line. This name should match the name shown on the charter or other legal document creating the entity. You may enter any business, trade, or DBA name on the "Business name" line.

**Note.** You are requested to check the appropriate box for your status (individual/sole proprietor, corporation, etc.).

### Exempt Payee

If you are exempt from backup withholding, enter your name as described above and check the appropriate box for your status, then check the "Exempt payee" box in the line following the business name, sign and date the form.

Generally, individuals (including sole proprietors) are not exempt from backup withholding. Corporations are exempt from backup withholding for certain payments, such as interest and dividends.

**Note.** If you are exempt from backup withholding, you should still complete this form to avoid possible erroneous backup withholding.

The following payees are exempt from backup withholding:

1. An organization exempt from tax under section 501(a), any IRA, or a custodial account under section 403(b)(7) if the account satisfies the requirements of section 401(f)(2),
  2. The United States or any of its agencies or instrumentalities,
  3. A state, the District of Columbia, a possession of the United States, or any of their political subdivisions or instrumentalities,
  4. A foreign government or any of its political subdivisions, agencies, or instrumentalities, or
  5. An international organization or any of its agencies or instrumentalities.
- Other payees that may be exempt from backup withholding include:
6. A corporation,
  7. A foreign central bank of issue,
  8. A dealer in securities or commodities required to register in the United States, the District of Columbia, or a possession of the United States,
  9. A futures commission merchant registered with the Commodity Futures Trading Commission,
  10. A real estate investment trust,
  11. An entity registered at all times during the tax year under the Investment Company Act of 1940,
  12. A common trust fund operated by a bank under section 584(a),
  13. A financial institution,
  14. A middleman known in the investment community as a nominee or custodian, or
  15. A trust exempt from tax under section 664 or described in section 4947.

The chart below shows types of payments that may be exempt from backup withholding. The chart applies to the exempt payees listed above, 1 through 15.

IF the payment is for . . .	THEN the payment is exempt for . . .
Interest and dividend payments	All exempt payees except for 9
Broker transactions	Exempt payees 1 through 13. Also, a person registered under the Investment Advisers Act of 1940 who regularly acts as a broker
Barter exchange transactions and patronage dividends	Exempt payees 1 through 5
Payments over \$600 required to be reported and direct sales over \$5,000 <sup>1</sup>	Generally, exempt payees 1 through 7

<sup>1</sup>See Form 1099-MISC, Miscellaneous Income, and its instructions.

<sup>2</sup>However, the following payments made to a corporation (including gross proceeds paid to an attorney under section 6045(f), even if the attorney is a corporation) and reportable on Form 1099-MISC are not exempt from backup withholding: medical and health care payments, attorneys' fees, and payments for services paid by a federal executive agency.

## Part I. Taxpayer Identification Number (TIN)

**Enter your TIN in the appropriate box.** If you are a resident alien and you do not have and are not eligible to get an SSN, your TIN is your IRS individual taxpayer identification number (ITIN). Enter it in the social security number box. If you do not have an ITIN, see *How to get a TIN* below.

If you are a sole proprietor and you have an EIN, you may enter either your SSN or EIN. However, the IRS prefers that you use your SSN.

If you are a single-member LLC that is disregarded as an entity separate from its owner (see *Limited liability company (LLC)* on page 2), enter the owner's SSN (or EIN, if the owner has one). Do not enter the disregarded entity's EIN. If the LLC is classified as a corporation or partnership, enter the entity's EIN.

**Note.** See the chart on page 4 for further clarification of name and TIN combinations.

**How to get a TIN.** If you do not have a TIN, apply for one immediately. To apply for an SSN, get Form SS-5, Application for a Social Security Card, from your local Social Security Administration office or get this form online at [www.ssa.gov](http://www.ssa.gov). You may also get this form by calling 1-800-772-1213. Use Form W-7, Application for IRS Individual Taxpayer Identification Number, to apply for an ITIN, or Form SS-4, Application for Employer Identification Number, to apply for an EIN. You can apply for an EIN online by accessing the IRS website at [www.irs.gov/businesses](http://www.irs.gov/businesses) and clicking on Employer Identification Number (EIN) under Starting a Business. You can get Forms W-7 and SS-4 from the IRS by visiting [www.irs.gov](http://www.irs.gov) or by calling 1-800-TAX-FORM (1-800-829-3676).

If you are asked to complete Form W-9 but do not have a TIN, write "Applied For" in the space for the TIN, sign and date the form, and give it to the requester. For interest and dividend payments, and certain payments made with respect to readily tradable instruments, generally you will have 60 days to get a TIN and give it to the requester before you are subject to backup withholding on payments. The 60-day rule does not apply to other types of payments. You will be subject to backup withholding on all such payments until you provide your TIN to the requester.

**Note.** Entering "Applied For" means that you have already applied for a TIN or that you intend to apply for one soon.

**Caution:** A disregarded domestic entity that has a foreign owner must use the appropriate Form W-8.

## Part II. Certification

To establish to the withholding agent that you are a U.S. person, or resident alien, sign Form W-9. You may be requested to sign by the withholding agent even if items 1, 4, and 5 below indicate otherwise.

For a joint account, only the person whose TIN is shown in Part I should sign (when required). Exempt payees, see *Exempt Payee* on page 2.

**Signature requirements.** Complete the certification as indicated in 1 through 5 below.

**1. Interest, dividend, and barter exchange accounts opened before 1984 and broker accounts considered active during 1983.** You must give your correct TIN, but you do not have to sign the certification.

**2. Interest, dividend, broker, and barter exchange accounts opened after 1983 and broker accounts considered inactive during 1983.** You must sign the certification or backup withholding will apply. If you are subject to backup withholding and you are merely providing your correct TIN to the requester, you must cross out item 2 in the certification before signing the form.



**3. Real estate transactions.** You must sign the certification. You may cross out item 2 of the certification.

**4. Other payments.** You must give your correct TIN, but you do not have to sign the certification unless you have been notified that you have previously given an incorrect TIN. "Other payments" include payments made in the course of the requester's trade or business for rents, royalties, goods (other than bills for merchandise), medical and health care services (including payments to corporations), payments to a nonemployee for services, payments to certain fishing boat crew members and fishermen, and gross proceeds paid to attorneys (including payments to corporations).

**5. Mortgage interest paid by you, acquisition or abandonment of secured property, cancellation of debt, qualified tuition program payments (under section 529), IRA, Coverdell ESA, Archer MSA or HSA contributions or distributions, and pension distributions.** You must give your correct TIN, but you do not have to sign the certification.

**Secure Your Tax Records from Identity Theft**

Identity theft occurs when someone uses your personal information such as your name, social security number (SSN), or other identifying information, without your permission, to commit fraud or other crimes. An identity thief may use your SSN to get a job or may file a tax return using your SSN to receive a refund.

To reduce your risk:

- Protect your SSN,
- Ensure your employer is protecting your SSN, and
- Be careful when choosing a tax preparer.

Call the IRS at 1-800-829-1040 if you think your identity has been used inappropriately for tax purposes.

Victims of identity theft who are experiencing economic harm or a system problem, or are seeking help in resolving tax problems that have not been resolved through normal channels, may be eligible for Taxpayer Advocate Service (TAS) assistance. You can reach TAS by calling the TAS toll-free case intake line at 1-877-777-4778 or TTY/TDD 1-800-829-4059.

**Protect yourself from suspicious emails or phishing schemes.** Phishing is the creation and use of email and websites designed to mimic legitimate business emails and websites. The most common act is sending an email to a user falsely claiming to be an established legitimate enterprise in an attempt to scam the user into surrendering private information that will be used for identity theft.

The IRS does not initiate contacts with taxpayers via emails. Also, the IRS does not request personal detailed information through email or ask taxpayers for the PIN numbers, passwords, or similar secret access information for their credit card, bank, or other financial accounts.

If you receive an unsolicited email claiming to be from the IRS, forward this message to [phishing@irs.gov](mailto:phishing@irs.gov). You may also report misuse of the IRS name, logo, or other IRS personal property to the Treasury Inspector General for Tax Administration at 1-800-366-4484. You can forward suspicious emails to the Federal Trade Commission at: [spam@uce.gov](mailto:spam@uce.gov) or contact them at [www.consumer.gov/idtheft](http://www.consumer.gov/idtheft) or 1-877-IDTHEFT(438-4338).

Visit the IRS website at [www.irs.gov](http://www.irs.gov) to learn more about identity theft and how to reduce your risk.

**What Name and Number To Give the Requester**

For this type of account:	Give name and SSN of:
1. Individual	The individual
2. Two or more individuals (joint account)	The actual owner of the account or, if combined funds, the first individual on the account
3. Custodian account of a minor (Uniform Gift to Minors Act)	The minor <sup>1</sup>
4. a. The usual revocable savings trust (grantor is also trustee)	The grantor-trustee
b. So-called trust account that is not a legal or valid trust under state law	The actual owner <sup>2</sup>
5. Sole proprietorship or disregarded entity owned by an individual	The owner <sup>3</sup>
For this type of account:	Give name and EIN of:
6. Disregarded entity not owned by an individual	The owner
7. A valid trust, estate, or pension trust	Legal entity <sup>4</sup>
8. Corporate or LLC electing corporate status on Form 8832	The corporation
9. Association, club, religious, charitable, educational, or other tax-exempt organization	The organization
10. Partnership or multi-member LLC	The partnership
11. A broker or registered nominee	The broker or nominee
12. Account with the Department of Agriculture in the name of a public entity (such as a state or local government, school district, or prison) that receives agricultural program payments	The public entity

<sup>1</sup> List first and circle the name of the person whose number you furnish. If only one person on a joint account has an SSN, that person's number must be furnished.

<sup>2</sup> Circle the minor's name and furnish the minor's SSN.

<sup>3</sup> You must show your individual name and you may also enter your business or "DBA" name on the second name line. You may use either your SSN or EIN (if you have one), but the IRS encourages you to use your SSN.

<sup>4</sup> List first and circle the name of the trust, estate, or pension trust. (Do not furnish the TIN of the personal representative or trustee unless the legal entity itself is not designated in the account title.) Also see *Special rules for partnerships* on page 1.

**Note.** If no name is circled when more than one name is listed, the number will be considered to be that of the first name listed.

**Privacy Act Notice**

Section 6109 of the Internal Revenue Code requires you to provide your correct TIN to persons who must file information returns with the IRS to report interest, dividends, and certain other income paid to you, mortgage interest you paid, the acquisition or abandonment of secured property, cancellation of debt, or contributions you made to an IRA, or Archer MSA or HSA. The IRS uses the numbers for identification purposes and to help verify the accuracy of your tax return. The IRS may also provide this information to the Department of Justice for civil and criminal litigation, and to cities, states, the District of Columbia, and U.S. possessions to carry out their tax laws. We may also disclose this information to other countries under a tax treaty, to federal and state agencies to enforce federal nontax criminal laws, or to federal law enforcement and intelligence agencies to combat terrorism.

You must provide your TIN whether or not you are required to file a tax return. Payers must generally withhold 28% of taxable interest, dividend, and certain other payments to a payee who does not give a TIN to a payer. Certain penalties may also apply.



**ENDORSEMENT NO.41**

**This endorsement, effective 12:01 AM: December 31, 2019**

**Forms a part of policy no.: EG 14362834**

**Issued to: SNF HOLDING COMPANY**

**By: AIG SPECIALTY INSURANCE COMPANY**

**THIS ENDORSEMENT CHANGES THE POLICY. PLEASE READ IT CAREFULLY.**

**ADDITIONAL INSURED PRIMARY AND NON-CONTRIBUTORY ENDORSEMENT -  
OWNERS, LESSEES OR CONTRACTORS - YOUR WORK**

**This endorsement modifies insurance provided under the following:**

**COMMERCIAL GENERAL LIABILITY AND  
POLLUTION LEGAL LIABILITY POLICY**

**SCHEDULE**

**Name of Additional Insured Person(s) or Organization(s):  
BLANKET WHERE REQUIRED BY WRITTEN CONTRACT OR AGREEMENT**

**I. Solely as respects **COVERAGE A - BODILY INJURY AND PROPERTY DAMAGE LIABILITY, COVERAGE B - PERSONAL AND ADVERTISING INJURY LIABILITY, COVERAGE E-2 PRODUCTS POLLUTION AND EXPOSURE LIABILITY, and COVERAGE E-3 - CONTRACTORS POLLUTION LIABILITY, SECTION II - WHO IS AN INSURED** is amended to include as an additional insured the person(s) or organization(s) shown in the Schedule, but only with respect to liability for bodily injury, property damage, personal and advertising injury, environmental damage or emergency response costs caused by:**

**A. Your acts or omissions, or**

**B. The acts or omissions of those acting on your behalf,**

**arising out of your work, including your work included in the products-completed operations hazard, or your product.**

**However:**

- 1. The insurance afforded to such additional insured only applies to the extent permitted by law, and**
- 2. If coverage provided to the additional insured is required by a contract or agreement, the insurance afforded to such additional insured will not be broader than that which you are required by the contract or agreement to provide for such additional insured.**

**ENDORSEMENT NO. 41 (Continued)**

- II. As respects the coverage afforded the additional insured(s) scheduled above, this insurance is primary and non-contributory, and our obligations are not affected by any other insurance carried by such additional insured(s) whether primary, excess, contingent, or on any other basis.
- III. With respect to the insurance afforded to these additional insureds, the following is added to **Section III - Limits Of Insurance:**
- If coverage provided to the additional insured is required by a contract or agreement, the most we will pay on behalf of the additional insured is the amount of insurance:
1. Required by the contract or agreement; or
  2. Available under the applicable Limits of Insurance shown in the Declarations;
- whichever is less.

This endorsement shall not increase the applicable Limits of Insurance shown in the Declarations.

All other terms, conditions and exclusions remain the same.

  
\_\_\_\_\_  
Authorized Representative  
or countersignature (where required by law)

**ENDORSEMENT**

This endorsement, effective 12:01 A.M. 12/31/2019 forms a part of

Policy No. CA 469-18-18 issued to SNF HOLDING COMPANY

by COMMERCE AND INDUSTRY INSURANCE COMPANY

**THIS ENDORSEMENT CHANGES THE POLICY. PLEASE READ IT CAREFULLY.**

**ADDITIONAL INSURED - WHERE REQUIRED UNDER CONTRACT OR AGREEMENT**

*This endorsement modifies insurance provided under the following:*

**BUSINESS AUTO COVERAGE FORM**

**SCHEDULE**

**ADDITIONAL INSURED:**

**ANY PERSON OR ORGANIZATION FOR WHOM YOU ARE CONTRACTUALLY BOUND TO PROVIDE ADDITIONAL INSURED STATUS BUT ONLY TO THE EXTENT OF SUCH PERSON'S OR ORGANIZATION'S LIABILITY ARISING OUT OF THE USE OF A COVERED AUTO.**

**I. SECTION II - COVERED AUTOS LIABILITY COVERAGE, A. Coverage, 1. - Who is insured, is amended to add:**

d. Any person or organization, shown in the schedule above, to whom you become obligated to include as an additional insured under this policy, as a result of any contract or agreement you enter into which requires you to furnish insurance to that person or organization of the type provided by this policy, but only with respect to liability arising out of use of a covered "auto". However, the insurance provided will not exceed the lesser of:

- (1) The coverage and/or limits of this policy, or
- (2) The coverage and/or limits required by said contract or agreement.

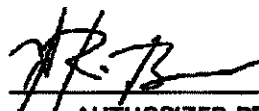

\_\_\_\_\_  
AUTHORIZED REPRESENTATIVE

**ENDORSEMENT**

This endorsement, effective 12:01 A.M. 12/31/2019 forms a part of

policy No. CA 469-18-18 issued to SNF HOLDING COMPANY

by COMMERCE AND INDUSTRY INSURANCE COMPANY

**THIS ENDORSEMENT CHANGES THE POLICY. PLEASE READ IT CAREFULLY.**

**WAIVER OF TRANSFER OF RIGHTS OF RECOVERY AGAINST OTHERS TO US**

*This endorsement modifies insurance provided under the following:*

**BUSINESS AUTO COVERAGE FORM**

**Section IV - Business Auto Conditions, A - Loss Conditions, 5 - Transfer of Rights of Recovery Against Others to Us, is amended to add:**

However, we will waive any right of recover we have against any person or organization with whom you have entered into a contract or agreement because of payments we make under this Coverage Form arising out of an "accident" or "loss" if:

- (1) The "accident" or "loss" is due to operations undertaken in accordance with the contract existing between you and such person or organization; and
- (2) The contract or agreement was entered into prior to any "accident" or "loss".

No waiver of the right of recovery will directly or indirectly apply to your employees or employees of the person or organization, and we reserve our rights or lien to be reimbursed from any recovery funds obtained by any injured employee.

  
\_\_\_\_\_  
AUTHORIZED REPRESENTATIVE



# CERTIFICATE OF ANALYSIS

Polydyne Inc.  
ONE CHEMICAL PLANT ROAD

RICEBORO GA 31323

**CUSTOMER NAME :**  
CITY OF FLINT, MI

**OA # :** 1383688 - 1 - 1

**FLINT MI 000**

dlewis@cityofflint.com  
DON LEWIS

**CITY OF FLINT, MI  
DIRECTOR OF FINANCE A/O  
P. O. BOX 246  
FLINT MI 48501  
UNITED STATES**

<b>POLYDYNE PRODUCT NAME :</b> CLARIFLOC CE-2141				
<b>PURCHASE ORDER NR :</b> 19-001539			<b>DATE :</b> 03/12/2020	
<b>AMOUNT :</b> 38250 LB				
			<b>QUALITY CONTROL</b>	<b>QC</b>
	<b>UNIT</b>	<b>SPECIFICATION</b>	<b>BATCH NUMBER RC20/6010M</b>	<b>TEST</b>
BULK BROOKFIELD VISCOSITY	cps	500 - 2000	1520	1010 A
NON VOLATILE SOLIDS	%	45.0 - 52.0	48.9	1050 A
UL BROOKFIELD VISCOSITY	cps	3.30 - 4.30	3.76	1019 A
RESIDUAL ACRYLAMIDE	ppm	0 - 999	20	1001 A
			<b>Date :</b> 03/13/2020	
			<b>Signature</b>	
			<b>Kiet Tran</b>	

If the # symbol appears in the QC-TEST column, then the data on that line is given for information only, and does not constitute a specification.

If ND appears in the result column, that means under the limit of detection.

For Personal Care ingredients, the generic name is corresponding to the INCI name.

SUP NR: OG-0098 REVISION: 04

# SNF

# POLYDYNE

## CLARIFLOC CE-2141 POLYMER

PRODUCT BULLETIN

### PRINCIPAL USES

CLARIFLOC CE-2141 is a high charge cationic polyacrylamide in emulsion form that is used as a flocculant in a wide variety of municipal wastewater treatment applications. It has been successfully applied in all liquid/solids separation systems including clarification, thickening, and dewatering.

### TYPICAL PROPERTIES

Physical Form	Clear to Milky White Liquid
Density	8.5 - 8.7 lbs/gal
Specific Gravity	1.02 - 1.04
Cationicity	60 %
Active Polyacrylamide Min.	42 %
Freezing Point	7 F. (-14 C.)

### PREPARATION AND FEEDING

CLARIFLOC CE-2141 is a single component emulsion polymer that must be pre-diluted in water before use. In most cases, this product should not be applied neat. One method for dilution is adding the neat polymer into the vortex of a mixed tank at a concentration between 0.25-1.0% polymer (0.5% is optimum) by weight. The polymer can also be injected through a number of commercially available systems that provide in-line mechanical mixing. The best feed systems use initial high energy mixing (>1000 rpm) for a short time (<30 sec) to achieve good dispersion followed by low energy mixing (<400 rpm) for a longer time (10-30 min). Polymer solutions should be aged for 15-60 minutes for best results. Solution shelf life is 8-16 hours.

### MATERIALS OF CONSTRUCTION

Cross-linked polyethylene, fiberglass, stainless steel or lined steel are the preferred materials of construction for bulk tanks. Avoid natural rubber and Buna-N gaskets as these materials swell when placed in contact with neat polymer. Unlined mild steel, black iron, galvanized steel, copper or brass are not recommended in any part of the feed system. Stainless steel, Viton or Teflon are the best choices for pump heads. For feed lines, use PVC or reinforced Tygon tubing.

### MANUFACTURING SPECIFICATIONS

Total Solids	45 - 52 %
Residual AcAm	< 1000 ppm
Neat Viscosity	500 - 2000 cPs
UL Viscosity	3.3 - 4.3 cPs

### HANDLING AND STORAGE

Suggested in-plant storage life is 12 months in unopened drums. For best results, store at 50-80 F. Bulk tanks should be mixed by periodically recirculating the contents bottom to top. Bulk tanks can also be fitted with an agitator type mixer that reaches the bottom 2 feet of the tank. Drums and bins should be mixed very well before first use and weekly after that. Do not allow emulsion polymers to freeze. Should freezing occur, allow the product to thaw thoroughly in a heated area and mix well before attempting to use it. For spills of CLARIFLOC CE-2141 sprinkle vermiculite or equivalent absorbent over the spill area and sweep the material into approved chemical disposal containers. Do not spray water onto a spill because the resulting gel is very difficult to clean up.

### SAFETY INFORMATION

CLARIFLOC CE-2141 is a mildly acidic product that can irritate the skin and eyes and should be handled accordingly. Gloves, goggles and apron are highly recommended. Anyone responsible for the procurement, use or disposal of this product should familiarize themselves with the appropriate safety and handling precautions involved. Such information is outlined in the POLYDYNE Material Safety Data Sheet. In the event of an emergency with this product, contact Chemtrec anytime day or night at (800) 424-9300.

### SHIPPING

CLARIFLOC CE-2141 Polymer is shipped in 55 gallon drums containing 450 pounds net or in 275 gallon totes containing 2300 pounds net. Bulk quantities are also available.

### ADDITIONAL INFORMATION

To place an order or obtain technical information from anywhere in the continental United States, call toll free:

**(800) 848-7659**

**For additional information, please refer to the Safety Data Sheet (SDS)**

All statements, information and data given herein are believed to be accurate, but are presented without warranty, expressed or implied. Statements concerning possible use are made without representation or warranty that any such use is free of patent infringement, and is not a recommendation to infringe on any patent. The user should not assume that all safety measures are indicated or that other measures may not be required. Any determination of the suitability of a particular product for any use contemplated by the user is the sole responsibility of the user.

© 2016 SNF Holding Company



# SAFETY DATA SHEET

According to U.S. Code of Federal Regulations 29 CFR 1910.1200, Hazard Communication.

---

## SECTION 1: Identification of the substance/mixture and of the company/undertaking

### 1.1. Product identifier

Product name: **CLARIFLOC CE-2141**

Type of product: Mixture.

### 1.2. Relevant identified uses of the substance or mixture and uses advised against

Identified uses: Processing aid for industrial applications.

Uses advised against: None.

### 1.3. Details of the supplier of the safety data sheet

Company: Polydyne Inc.  
1 Chemical Plant Road  
PO BOX 279, Riceboro, GA 31323  
United States

Telephone: 1-800-848-7659

Telefax: (912)-884-8770

E-mail address: -

### 1.4. Emergency telephone number

24-hour emergency number: 1-800-424-9300

## SECTION 2: Hazards identification

### 2.1. Classification of the substance or mixture

Classification according to paragraph (d) of 29 CFR 1910.1200:

Not classified.

### 2.2. Label elements

Labelling according to paragraph (f) of 29 CFR 1910.1200:

Hazard symbol(s): None.

Signal word: None.

Hazard statement(s): None.

Precautionary statement(s): None.

### 2.3. Other hazards

Spills produce extremely slippery surfaces.

For explanation of abbreviations see Section 16.

## **SECTION 3: Composition/information on ingredients**

### 3.1. Substances

Not applicable, this product is a mixture.

### 3.2. Mixtures

This product is a mixture.

#### Hazardous components

##### Distillates (petroleum), hydrotreated light

Concentration/ -range: 20 - 30%

CAS Number: 64742-47-8

Classification according to paragraph (d)  
of 29 CFR 1910.1200: Asp. Tox. 1;H304

#### Notes

Does not result in classification of the mixture if the kinematic viscosity is greater than 20.5 mm<sup>2</sup>/s measured at 40°C.

##### Alcohols, C11-14-iso-, C13-rich, ethoxylated

Concentration/ -range: < 6%

CAS Number: 78330-21-9

Classification according to paragraph (d)  
of 29 CFR 1910.1200: Eye Dam. 1;H318

For explanation of abbreviations see section 16

## **SECTION 4: First aid measures**

**SECTION 4: First aid measures****4.1. Description of first aid measures****Inhalation:**

Move to fresh air. No hazards which require special first aid measures.

**Skin contact:**

Wash off immediately with soap and plenty of water while removing all contaminated clothes and shoes. In case of persistent skin irritation, consult a physician.

**Eye contact:**

Rinse immediately with plenty of water, also under the eyelids, for at least 15 minutes. Get medical attention immediately.

**Ingestion:**

Rinse mouth with water. Do NOT induce vomiting. Call a physician or poison control centre immediately.

**4.2. Most important symptoms and effects, both acute and delayed**

None under normal use.

**4.3. Indication of any immediate medical attention and special treatment needed.**

None reasonably foreseeable.

**Other information:**

None.

**SECTION 5: Fire-fighting measures****5.1. Extinguishing media****Suitable extinguishing media:**

Water. Water spray. Foam. Carbon dioxide (CO<sub>2</sub>). Dry powder.

Warning! Spills produce extremely slippery surfaces.

**Unsuitable extinguishing media:**

None.

**5.2. Special hazards arising from the substance or mixture****Hazardous decomposition products:**

Ammonia. Carbon oxides (CO<sub>x</sub>). Nitrogen oxides (NO<sub>x</sub>). Hydrogen chloride. Hydrogen cyanide (hydrocyanic acid) may be produced in the event of combustion in an oxygen deficient atmosphere.

**5.3. Advice for fire-fighters****Protective measures:**

Wear self-contained breathing apparatus and protective suit.

**Other information:**

Spills produce extremely slippery surfaces.

**SECTION 6: Accidental release measures***6.1. Personal precautions, protective equipment and emergency procedures**Personal precautions:*

Do not touch or walk through spilled material. Spills produce extremely slippery surfaces.

*Protective equipment:*

Wear adequate personal protective equipment (see Section 8 Exposure Controls/Personal Protection).

*Emergency procedures:*

Keep people away from spill/leak. Prevent further leakage or spillage if safe to do so.

*6.2. Environmental precautions*

Do not contaminate water.

*6.3. Methods and material for containment and cleaning up**Small spills:*

Do not flush with water. Soak up with inert absorbent material. Sweep up and shovel into suitable containers for disposal.

*Large spills:*

Do not flush with water. Dam up. Soak up with inert absorbent material. Clean up promptly by scoop or vacuum.

*Residues:*

After cleaning, flush away traces with water.

*6.4. Reference to other sections*

SECTION 7: Handling and storage; SECTION 8: Exposure controls/personal protection; SECTION 13: Disposal considerations;

**SECTION 7: Handling and storage***7.1. Precautions for safe handling*

Avoid contact with skin and eyes. Renders surfaces extremely slippery when spilled. When using, do not eat, drink or smoke.

*7.2. Conditions for safe storage, including any incompatibilities*

Keep away from heat and sources of ignition. Freezing will affect the physical condition and may damage the material. Incompatible with oxidizing agents.

*7.3. Specific end use(s)*

None.

**SECTION 8: Exposure controls/personal protection***8.1. Control parameters**Occupational exposure limits:*

---

Distillates (petroleum), hydrotreated light  
ACGIH: 200 mg/m<sup>3</sup> (8 hours)

## 8.2. Exposure controls

### Appropriate engineering controls:

Use local exhaust if misting occurs. Natural ventilation is adequate in absence of mists. Ensure adequate ventilation, especially in confined areas.

### Individual protection measures, such as personal protective equipment:

#### a) Eye/face protection:

Safety glasses with side-shields.

#### b) Skin protection:

i) Hand protection: PVC or other plastic material gloves.

ii) Other: Wear coveralls and/or chemical apron and rubber footwear where physical contact can occur.

#### c) Respiratory protection:

No personal respiratory protective equipment normally required.

#### d) Additional advice:

Wash hands before breaks and at the end of workday. Wash hands before breaks and immediately after handling the product. Handle in accordance with good industrial hygiene and safety practice.

### Environmental exposure controls:

Do not allow uncontrolled discharge of product into the environment.

## **SECTION 9: Physical and chemical properties**

### 9.1. Information on basic physical and chemical properties

a) Appearance:	Viscous liquid, Milky.
b) Odour:	Aliphatic.
c) Odour Threshold:	No data available.
d) pH:	3.5 - 6.5 @ 5 g/L
e) Melting point/freezing point:	< 5°C
f) Initial boiling point and boiling range:	> 100°C
g) Flash point:	Does not flash.
h) Evaporation rate:	No data available.

<i>i) Flammability (solid, gas):</i>	Not applicable.
<i>j) Upper/lower flammability or explosive limits:</i>	Not expected to create explosive atmospheres.
<i>k) Vapour pressure:</i>	2.3 kPa @ 20°C
<i>l) Vapour density:</i>	No data available.
<i>m) Relative density:</i>	1.0 - 1.2
<i>n) Solubility(ies):</i>	Completely miscible.
<i>o) Partition coefficient:</i>	Not applicable.
<i>p) Autoignition temperature:</i>	Not applicable.
<i>q) Decomposition temperature:</i>	> 150°C
<i>r) Viscosity:</i>	> 20.5 mm <sup>2</sup> /s @ 40°C
<i>s) Explosive properties:</i>	Not expected to be explosive based on the chemical structure.
<i>t) Oxidizing properties:</i>	Not expected to be oxidising based on the chemical structure.

#### 9.2. Other information

None.

### **SECTION 10: Stability and reactivity**

#### 10.1. Reactivity

Stable under recommended storage conditions.

#### 10.2. Chemical stability

Stable under recommended storage conditions.

#### 10.3. Possibility of hazardous reactions

Oxidizing agents may cause exothermic reactions.

#### 10.4. Conditions to avoid

Protect from frost, heat and sunlight.

#### 10.5. Incompatible materials

Oxidizing agents.

#### 10.6. Hazardous decomposition products

Thermal decomposition may produce: hydrogen chloride gas, nitrogen oxides (NO<sub>x</sub>), carbon oxides (CO<sub>x</sub>). Ammonia. Hydrogen cyanide (hydrocyanic acid) may be produced in the event of combustion in an oxygen deficient atmosphere.

**SECTION 11: Toxicological information**

## 11.1. Information on toxicological effects

Information on the product as supplied:

Acute oral toxicity:	LD50/oral/rat > 5000 mg/kg
Acute dermal toxicity:	LD50/dermal/rat > 5000 mg/kg.
Acute inhalation toxicity:	The product is not expected to be toxic by inhalation.
Skin corrosion/irritation:	Non-irritating to skin.
Serious eye damage/eye irritation:	Not irritating. (OECD 437) (Based on results obtained from tests on analogous products)
Respiratory/skin sensitisation:	Not sensitizing.
Mutagenicity:	Not mutagenic.
Carcinogenicity:	Not carcinogenic.
Reproductive toxicity:	Not toxic for reproduction.
STOT - Single exposure:	No known effects.
STOT - Repeated exposure:	No known effect.
Aspiration hazard:	Due to the viscosity, this product does not present an aspiration hazard.

Relevant information on the hazardous components:Distillates (petroleum), hydrotreated light

Acute oral toxicity:	LD50/oral/rat > 5000 mg/kg (OECD 401)
Acute dermal toxicity:	LD50/dermal/rabbit > 5000 mg/kg. (OECD 402)
Acute inhalation toxicity:	LC0/inhalation/4 hours/rat $\geq$ 4951 mg/m <sup>3</sup> (OECD 403) (Based on results obtained from tests on analogous products)
Skin corrosion/irritation:	Not irritating. (OECD 404) Repeated exposure may cause skin dryness or cracking.
Serious eye damage/eye irritation:	Not irritating. (OECD 405)
Respiratory/skin sensitisation:	By analogy with similar products, this product is not expected to be sensitizing. (OECD 406)

<i>Mutagenicity:</i>	Not mutagenic. (OECD 471, 473, 474, 476, 478, 479)
<i>Carcinogenicity:</i>	Carcinogenicity study in rats (OECD 451): Negative.
<i>Reproductive toxicity:</i>	By analogy with similar substances, this substance is not expected to be toxic for reproduction. NOAEL/rat = 300 ppm. (OECD 421)
<i>STOT - Single exposure:</i>	No known effects.
<i>STOT - Repeated exposure:</i>	NOAEL/oral/rat/90 days >= 3000 mg/kg/day (OECD 408) (Based on results obtained from tests on analogous products)
<i>Aspiration hazard:</i>	May be fatal if swallowed and enters airways.

*Alcohols, C11-14-iso-, C13-rich, ethoxylated*

<i>Acute oral toxicity:</i>	LD50/oral/rat > 2000 mg/kg
<i>Acute dermal toxicity:</i>	LD50/dermal/rat > 2000 mg/kg.
<i>Acute inhalation toxicity:</i>	No data available.
<i>Skin corrosion/irritation:</i>	Not irritating.
<i>Serious eye damage/eye irritation:</i>	Risk of serious damage to eyes.
<i>Respiratory/skin sensitisation:</i>	The product is not expected to be sensitizing.
<i>Mutagenicity:</i>	Negative in the Ames Test (OECD 471).
<i>Carcinogenicity:</i>	Based on the absence of mutagenicity, it is unlikely that the substance is carcinogenic.
<i>Reproductive toxicity:</i>	No data available.
<i>STOT - Single exposure:</i>	No known effects.
<i>STOT - Repeated exposure:</i>	No known effect.
<i>Aspiration hazard:</i>	No known effects.

**SECTION 12: Ecological information**

*12.1. Toxicity*



Information on the product as supplied:

Acute toxicity to fish:	LC50/Fish/96 hours = 10 - 100 mg/L (Estimated)
Acute toxicity to invertebrates:	EC50/Daphnia magna/48 hours = 10 - 100 mg/L. (Estimated)
Acute toxicity to algae:	Algal inhibition tests are not appropriate. The flocculation characteristics of the product interfere directly in the test medium preventing homogenous distribution which invalidates the test.
Chronic toxicity to fish:	No data available.
Chronic toxicity to invertebrates:	No data available.
Toxicity to microorganisms:	No data available.
Effects on terrestrial organisms:	No data available.
Sediment toxicity:	No data available.

Relevant information on the hazardous components:Distillates (petroleum), hydrotreated light

Acute toxicity to fish:	LC0/Oncorhynchus mykiss/96 hours > 1000 mg/L. (OECD 203)
Acute toxicity to invertebrates:	EC0/Daphnia magna/48 hours > 1000 mg/L. (OECD 202)
Acute toxicity to algae:	IC0/Pseudokirchneriella subcapitata/72 hours > 1000 mg/L. (OECD 201)
Chronic toxicity to fish:	NOEC/Oncorhynchus mykiss/28 days > 1000 mg/L
Chronic toxicity to invertebrates:	NOEC/Daphnia magna/21 days > 1000 mg/L
Toxicity to microorganisms:	EC50/Tetrahymena pyriformis/ 48h > 1000 mg/L.
Effects on terrestrial organisms:	No data available.
Sediment toxicity:	No data available. Readily biodegradable, exposure to sediment is unlikely.

Alcohols, C11-14-iso-, C13-rich, ethoxylated

Acute toxicity to fish:	LC50/Fish/96 hours = 1 - 10 mg/L (Estimated)
Acute toxicity to invertebrates:	EC50/Daphnia magna/48 hours = 1 - 10 mg/L. (Estimated)

<i>Acute toxicity to algae:</i>	IC50/Algae/72 hours = 1 - 10 mg/L (Estimated)
<i>Chronic toxicity to fish:</i>	Harmful to aquatic organisms, may cause long-term adverse effects in the aquatic environment.
<i>Chronic toxicity to invertebrates:</i>	Harmful to aquatic organisms, may cause long-term adverse effects in the aquatic environment.
<i>Toxicity to microorganisms:</i>	No data available.
<i>Effects on terrestrial organisms:</i>	No data available.
<i>Sediment toxicity:</i>	No data available.

### 12.2. Persistence and degradability

#### Information on the product as supplied:

<i>Degradation:</i>	Readily biodegradable.
<i>Hydrolysis:</i>	At natural pHs (>6) the polymer degrades due to hydrolysis to more than 70% in 28 days. The hydrolysis products are not harmful to aquatic organisms.
<i>Photolysis:</i>	No data available.

#### Relevant information on the hazardous components:

##### Distillates (petroleum), hydrotreated light

<i>Degradation:</i>	Readily biodegradable. 67.6% / 28 days (OECD 301 F) ; 68.8% / 28 days (OECD 306) ; 61.2% / 61 days (OECD 304 A)
<i>Hydrolysis:</i>	Does not hydrolyse.
<i>Photolysis:</i>	No data available.

##### Alcohols, C11-14-iso-, C13-rich, ethoxylated

<i>Degradation:</i>	Readily biodegradable. > 70% / 28 days (OECD 301 E)
<i>Hydrolysis:</i>	No data available.
<i>Photolysis:</i>	No data available.

### 12.3. Bioaccumulative potential

Information on the product as supplied:

The product is not expected to bioaccumulate.

Partition co-efficient (Log Pow): Not applicable.

Bioconcentration factor (BCF): No data available.

Relevant information on the hazardous components:Distillates (petroleum), hydrotreated light

Partition co-efficient (Log Pow): 3 - 6

Bioconcentration factor (BCF): No data available.

Alcohols, C11-14-iso-, C13-rich, ethoxylated

Partition co-efficient (Log Pow): Not applicable.

Bioconcentration factor (BCF): No data available.

## 12.4. Mobility in soil

Information on the product as supplied:

No data available.

Relevant information on the hazardous components:Distillates (petroleum), hydrotreated light

Koc: No data available.

Alcohols, C11-14-iso-, C13-rich, ethoxylated

Koc: No data available.

## 12.5. Other adverse effects

None.

**SECTION 13: Disposal considerations**

## 13.1. Waste treatment methods

Waste from residues/unused products:

Dispose of in accordance with local regulations. Can be landfilled or incinerated, when in compliance with local regulations.

Contaminated packaging:

Rinse empty containers with water and use the rinse-water to prepare the working solution. If recycling is not practicable, dispose of in compliance with local regulations. Can be landfilled or incinerated, when in compliance with local regulations.

Recycling:

Store containers and offer for recycling of material when in accordance with the local regulations.

**SECTION 14: Transport information**

*Land transport (DOT)*

Not classified.

*Sea transport (IMDG)*

Not classified.

*Air transport (IATA)*

Not classified.

**SECTION 15: Regulatory information**

*15.1. Safety, health and environmental regulations/legislation specific for the substance or mixture*

Information on the product as supplied:

TSCA Chemical Substances Inventory:

All components of this product are either listed on the inventory or are exempt from listing.

US SARA Reporting Requirements:

*SARA (Section 311/312) hazard class:*

Not concerned.

SARA Title III Sections:

*Section 302 (TPQ) - Reportable Quantity:*

Not concerned.

*Section 304 - Reportable Quantity:*

Not concerned.

*Section 313 (De minimis concentration):*

Not concerned.

Clean Water Act

*Section 311 Hazardous Substances (40 CFR 117.3) - Reportable Quantity:*  
Not concerned.

**Clean Air Act**

*Section 112(r) Accidental release prevention requirements (40 CFR 68) - Reportable Quantity:*  
Not concerned.

**CERCLA**

*Hazardous Substances List (40 CFR 302.4) - Reportable Quantity:*  
Not concerned.

**RCRA status:**

Not RCRA hazardous.

**California Proposition 65 Information:**

**WARNING!** This product contains a chemical known to the State of California to cause cancer and birth defects or other reproductive harm, Acrylamide

**SECTION 16: Other information**

**NFPA and HMIS Ratings:**

**NFPA:**

Health:	0
Flammability:	1
Instability:	0

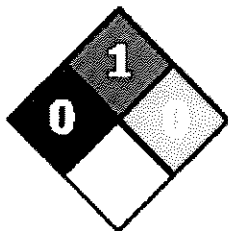

**HMIS:**

Health:	0
Flammability:	1
Physical Hazard:	0
PPE Code:	B

*This data sheet contains changes from the previous version in section(s):*

SECTION 2. Hazards identification, SECTION 3. Composition/information on ingredients, SECTION 4. First aid measures, SECTION 5. Fire-fighting measures, SECTION 6. Accidental release measures, SECTION 7. Handling and storage, SECTION 8. Exposure controls/personal protection, SECTION 9. Physical and chemical properties, SECTION 10. Stability and reactivity, SECTION 11. Toxicological information, SECTION 12. Ecological information, SECTION 13. Disposal considerations, SECTION 14. Transport information, SECTION 15. Regulatory information, SECTION 16. Other Information.

*Key or legend to abbreviations and acronyms used in the safety data sheet:*

**Acronyms**

STOT = Specific target organ toxicity

**Abbreviations**

Asp. Tox. 1 = Aspiration hazard Category Code 1

Eye Dam 1 = Serious eye damage/eye irritation Category Code 1

**Hazard statements**

H304 - May be fatal if swallowed and enters airways

H318 - Causes serious eye damage

**Training advice:**

Do not handle until all safety precautions have been read and understood.

*This SDS was prepared in accordance with the following:*

U.S. Code of Federal Regulations 29 CFR 1910.1200

---

Version: 18.01.a

ENCC042

The information provided in this Safety Data Sheet is correct to the best of our knowledge, information and belief at the date of its publication. The information given is designed only as a guidance for safe handling, use, processing, storage, transportation, disposal and release and is not to be considered a warranty or quality specification. The information relates only to the specific material designated and may not be valid for such material used in combination with any other materials or in any process, unless specified in the text.



RESOLUTION NO.: 210262

PRESENTED: JUN - 6 2021

ADOPTED: \_\_\_\_\_

PROPOSAL# 22000549

BY THE CITY ADMINISTRATOR:

**RESOLUTION TO EJ USA, INC. FOR FIRE HYDRANTS, GRATES, AND MANHOLE COVERS**

WHEREAS, Water Service Center (WSC) requires fire hydrants, grates, and manhole covers for the repair and maintenance of the City's water supply and sewage disposal system. The WSC recommends that the bid be issued to EJ USA, Inc. for FY2022 and FY2023 for the purchase of fire hydrants, grates, and manhole covers.

Account Number	Account Name	Amount
590-540.208-752.000	Supplies	\$25,000.00
591-540.202-752.000	Supplies	\$95,000.00
	<b>FY2022 GRAND TOTAL</b>	<b>\$120,000.00</b>

IT IS RESOLVED, that the appropriate City Officials are authorized to do all things necessary to enter into a contract with EJ USA, Inc. to provide fire hydrants, grates, and manhole covers for FY2022, pending budget adoption, for the amount of \$120,000.00.

APPROVED AS TO FORM:

Angela Wheeler  
Angela Wheeler (May 24, 2021 09:13 EDT)  
Angela Wheeler, Chief Legal Officer

APPROVED AS TO FINANCE:

Shelbi Frayer  
Shelbi Frayer (May 24, 2021 11:06 EDT)  
Shelbi Frayer, Chief Financial Officer

FOR THE CITY OF FLINT:

Clyde D. Edwards  
Clyde D Edwards (May 24, 2021 14:44 EDT)  
Clyde Edwards, City Administrator

APPROVED BY CITY COUNCIL:

\_\_\_\_\_  
Kate Fields, City Council President

APPROVED AS TO PURCHASING:

Jennifer Ryan  
Jennifer Ryan (May 21, 2021 15:33 EDT)  
Jenn Ryan, Deputy Finance Director



# CITY OF FLINT

## Department of Public Works & Utilities

Sheldon Neeley  
Mayor

Paul Simpson  
Water Distribution Supervisor

Entrice Mitchell  
Sewer Maintenance Supervisor

## MEMORANDUM

**TO:** Jennifer Ryan  
Deputy Finance Director

**FROM:** Paul Simpson   
Water Distribution Supervisor

**DATE:** May 20, 2021

**SUBJECT:** Bid Recommendation –Hydrants, Grates and Covers

Recommend that proposal #22000549 for 2 years be awarded to the lowest cumulative bidder, EJ USA, Inc.







## CITY OF FLINT

---

WILL YOUR DEPARTMENT NEED A CONTRACT? YES  NO

WHEN APPLICABLE, IF MORE THAN ONE (1) YEAR, PLEASE ESTIMATE TOTAL AMOUNT FOR EACH BUDGET YEAR: *(This will depend on the term of the bid proposal)*

BUDGET YEAR 1

BUDGET YEAR 2

BUDGET YEAR 3

OTHER IMPLICATIONS *(i.e., collective bargaining)*:

STAFF RECOMMENDATION: *(PLEASE SELECT)*:  APPROVED  NOT APPROVED

DEPARTMENT HEAD SIGNATURE: \_\_\_\_\_

*(Michael J. Brown, DPW Director)*



**SEALED PROPOSALS RECEIVED IN THE DIVISION OF PURCHASES & SUPPLIES**  
**For Hydrants, Grates and Manhole Covers – (2) Years**  
**PROPOSAL# 22000549**  
 Approximate Annual Quantities – Not Guaranteed  
 Furnish as requested for the period 7/1/21 – 6/30/23

<b>Vendor</b>	<b>Description</b>	<b>Total Year 1 - FY22</b>	<b>Total Year 2 - FY23</b>
Core & Main, LP Canton, MI	Grates & Manhole Covers	<b>\$2,430.57</b>	<b>\$2,430.57</b>
	Hydrants	<b>\$3,420.27</b>	<b>\$3,420.27</b>
EJ USA, Inc. East Jordan, MI	Grates & Manhole Covers	<b>\$2,347.06</b>	<b>\$2,402.95</b>
	Hydrants	<b>\$3,293.68</b>	<b>\$3,642.89</b>

**A SPECIAL NOTE FROM THE PURCHASING DIVISION**  
*Bid results posted are before evaluation team review and award recommendation.*



**City of Flint**  
**Department of Finance**  
**Division of Purchases & Supplies**

---

Sheldon A. Neeley

May 14, 2021

**TO:** Michael Brown  
**FROM:** Jennifer Ryan  
Deputy Finance Director  
**SUBJECT:** SEALED BIDS

Attached are two (2) bids that were received for **PROPOSAL #22000549 – HYDRANTS, GRATES AND MANHOLE COVERS – (2) YEARS**. Enclosed are copies for your file. **Bid Due Date: 5/13/21. Enclosed is a spreadsheet.**

Your staff review and recommendation form is needed as soon as possible. **Please use the new fillable form.** This form is to be used for your staff review.

A staff review must be completed for **ALL Bids/Proposals**. Please let me know if you need a copy of the fillable form.

**Please note:** If your project is being funded by any grants issued by the federal government, you must go to:  
<https://www.dol.gov/ofccp/regs/compliance/preaward/debarlist.htm> to ensure that the selected vendor has not been debarred.

**PLEASE NOTE:**

Results may be viewed next business day online **EXCEPT** when a bid is under review. The bidders/public will only see the names of the bidders that submitted a bid, not their cost. This will protect the bidders cost in case there is a re-bid.

**If you have any questions, please feel free to give me a call or send an email.**

Signature 

cc: Shelbi Frayer

## ❖ EXHIBIT A - SUBMITTAL WITH DETAILED SUMMARY OF PRICING

**BID NO. 22000549**  
**HYDRANTS, GRATES AND MANHOLE COVERS - (2) YEARS**

**REQUIREMENTS/TABULATION**

Furnish as requested within 48 hours' notice beginning 7/1/2021 and ending 06/30/2023. Items shall be East Jordan Iron Works or approved equivalent. An hour delivery notification required for all shipments requiring the use of a fork lift. If notification is not made, the City reserves the right to refuse delivery at no additional cost to the City.

LN#	ITEM ID	DESCRIPTION	UOM	TOTAL YEAR 1 – FY22	TOTAL YEAR 2 – FY23
1	4000068010	Frame, Catch Basin, #700010	EA	223.34	228.66
2	4000070010	Grate, Regular, Catch Basin, #700030	EA	147.75	151.27
3	4000072010	Hood, Catch Basin, #700065	EA	150.72	154.31
4	4000069000	Grate, X.L., driveway, catch basin #7000M3 "DUMP NO WASTE!" DRAINS TO WATERWAYS (fish emblem)	EA	277.21	283.81
5	4000064000	Cover, open grate, manhole #107530 "DUMP NO WASTE! DRAINS TO WATERWAYS" (FISH EMBLEM)	EA	215.77	220.91
6	4000071000	Grate, State, Catch Basin	EA	135.46	138.68
8	4000070000	Grate, regular, catch basin	EA	147.75	151.27
9	4000075000	Frame, manhole #1075	EA	362.56	371.19
10		Sewer cover #1075	EA	200.63	205.41
11		MH cover, 1040-1 Z Frame Pressure Tight with 1040A solid cover pressure tight gasket seal, Flint sanitary sewer assembly to say "City of Flint" on same. 1040-1ZPT, 1040APTGS Flint SS ASY	EA	485.87	497.44
<b>GRAND TOTAL UNIT PRICING</b>				<b>\$ 2,347.06</b>	<b>\$ 2,402.95</b>

Only the specifier has the responsibility and judgment for determining whether a proposed substitution is an "or equal or exceeding" specification. Mfg., model #, and supporting documentation of specifications for alternates must be provided.

**All shipping and freight charges are to be included in the bid pricing.**

Company Name: EJ USA, Inc.

**REQUIREMENTS/TABULATION**

Furnish as requested within 48 hours' notice beginning 7/1/2021 and ending 06/30/2023. Hydrants must be East Jordan Iron Works 5BR-250. **1 hour delivery notification required for all shipments requiring the use of a fork lift. If notification is not made, the City reserves the right to refuse delivery at no additional cost to the City.**

LN#	ITEM ID	DESCRIPTION	UOM	TOTAL YEAR 1- FY22	TOTAL YEAR 2- FY23
		<b>FIRE HYDRANTS</b>			
1	8910065000	M.J. oversized 5'6", open right, 2-1/2" NS hose connections. 4-1/2" NS pumper, yellow, 7/8" sq. Hydrant must come with weep hole plugged	EA	1,985.32	2,021.42
		<b>B84-B</b>			
2	8800000000	6" EJW Hydrant Extension	EA	234.48	235.54
3	8800000000	12" EJW Hydrant Extension	EA	271.81	275.39
4	8800000000	18" EJW Hydrant Extension	EA	308.52	312.58
5	8800000000	24" EJW Hydrant Extension	EA	334.74	339.15
6		Hydrant Wrenches	EA	50.00	50.00
7		Food grade anti-seize 7lb can	EA	108.81	108.81
		<b>GRAND TOTAL UNIT PRICING</b>		<b>\$ 3,293.68</b>	<b>\$ 3,642.89</b>

**PLEASE NOTE**

Only the specifier has the responsibility and judgment for determining whether a proposed substitution is an "or equal or exceeding" specification. Mfg., model #, and supporting documentation of specifications for alternates must be provided.

**All shipping and freight charges are to be included in the bid pricing.**

Company Name: EJ USA, Inc.

**All proposals will be evaluated on the following criteria:**

P22000549 – HYDRANTS, GRATES AND MANHOLE COVERS – (2) YEARS

1. Failure to use this bid form shall result in bid disqualification.
2. Failure to bid on all items shall result in an "incomplete bid" determination.
3. List value-added considerations on a separate sheet of paper.
4. All bid pricing to include shipping and freight charges.

**THIS PAGE MUST BE COMPLETED AND INCLUDED WITH THE BID**

The undersigned hereby certifies, on behalf of the respondent named in this Certification (the "Respondent"), that the information provided in this offer submitted to the City of Flint, Department of Purchase and Supplies is accurate and complete, and that I am duly authorized to submit same. I hereby certify that the Respondent has reviewed all documents and requirements included in this offer and accept its terms and conditions.

Terms: 0 Net 30Fed. ID #: 38-1434427Company (Respondent): EJ USA, Inc.Address: 301 Spring Street, PO Box 439City, State & Zip Code: East Jordan, MI 49727Phone / Fax Number: 1-800-874-4100 FAX: 231-536-4458Email: us.bids@ejco.comPrint Name and Title: Thomas M. Teske, Vice President & General Manager  
(Authorized Representative)

Signed:

  
(Authorized Representative)

## ❖ EXHIBIT A - SUBMITTAL WITH DETAILED SUMMARY OF PRICING

**BID NO.22000549**  
**HYDRANTS, GRATES AND MANHOLE COVERS - (2) YEARS**

**REQUIREMENTS/TABULATION**

Furnish as requested within 48 hours' notice beginning 7/1/2021 and ending 06/30/2023. Items shall be East Jordan Iron Works or approved equivalent. An hour delivery notification required for all shipments requiring the use of a fork lift. If notification is not made, the City reserves the right to refuse delivery at no additional cost to the City.

LN#	ITEM ID	DESCRIPTION	UOM	TOTAL YEAR 1 – FY22	TOTAL YEAR 2 – FY23
1	4000068010	Frame, Catch Basin, #700010	EA	231.29	231.29
2	4000070010	Grate, Regular, Catch Basin, #700030	EA	153.01	153.01
3	4000072010	Hood, Catch Basin, #700065	EA	156.09	156.09
4	4000069000	Grate, X.L., driveway, catch basin #7000M3 "DUMP NO WASTE" DRAINS TO WATERWAYS (fish emblem)	EA	287.07	287.07
5	4000064000	Cover, open grate, manhole #107530 "DUMP NO WASTE" DRAINS TO WATERWAYS" (FISH EMBLEM)	EA	223.45	223.45
6	4000071000	Grate, State, Catch Basin	EA	140.28	140.28
8	4000070000	Grate, regular, catch basin	EA	153.01	153.01
9	4000075000	Frame, manhole #1075	EA	375.45	375.45
10		Sewer cover #1075	EA	207.77	207.77
11		MH cover, 1040-1 Z Frame Pressure Tight with 1040A solid cover pressure tight gasket seal, Flint sanitary sewer assembly to say "City of Flint" on same. 1040-1ZPT, 1040APTGS Flint SS ASY	EA	503.15	503.15
<b>GRAND TOTAL UNIT PRICING</b>				<b>\$ 2,430.57</b>	<b>\$ 2,430.57</b>

Only the specifier has the responsibility and judgment for determining whether a proposed substitution is an "or equal or exceeding" specification. Mfg., model #, and supporting documentation of specifications for alternates must be provided.

All shipping and freight charges are to be included in the bid pricing.

Company Name: Core & Main LP



**REQUIREMENTS/TABULATION**

Furnish as requested within 48 hours' notice beginning 7/1/2021 and ending 06/30/2023. Hydrants must be East Jordan Iron Works SBR-250. 1 hour delivery notification required for all shipments requiring the use of a fork lift. If notification is not made, the City reserves the right to refuse delivery at no additional cost to the City.

LN#	ITEM ID	DESCRIPTION	UOM	TOTAL YEAR 1- FY22	TOTAL YEAR 2- FY23
<b>FIRE HYDRANTS</b>					
1	8910065000	M.J. oversized 5'6", open right, 2-1/2" NS hose connections. 4-1/2" NS pumper, yellow, 7/8" sq. Hydrant must come with weep hole plugged	EA	2072.36	2072.36
<b>B84-B</b>					
2	8800000000	6" EJW Hydrant Extension	EA	239.48	239.48
3	8800000000	12" EJW Hydrant Extension	EA	280.00	280.00
4	8800000000	18" EJW Hydrant Extension	EA	317.81	317.81
5	8800000000	24" EJW Hydrant Extension	EA	344.83	344.83
6		Hydrant Wrenches	EA	52.20	52.20
7		Food grade anti-selze 7lb can	EA	113.59	113.59
<b>GRAND TOTAL UNIT PRICING</b>				<b>\$ 3420.27</b>	<b>\$ 3420.27</b>

**PLEASE NOTE**

Only the specifier has the responsibility and judgment for determining whether a proposed substitution is an "or equal or exceeding" specification. Mfg., model #, and supporting documentation of specifications for alternates must be provided.

**All shipping and freight charges are to be included in the bid pricing.**

Company Name: Core & Main LP

All proposals will be evaluated on the following criteria:



# City of Flint

## Department of Finance

### Division of Purchases & Supplies

---

Sheldon A. Neeley

May 14, 2021

**TO:** Michael Brown  
**FROM:** Jennifer Ryan  
Deputy Finance Director  
**SUBJECT:** SEALED BIDS

Attached are two (2) bids that were received for **PROPOSAL #22000549 – HYDRANTS, GRATES AND MANHOLE COVERS – (2) YEARS**. Enclosed are copies for your file. **Bid Due Date: 5/13/21. Enclosed is a spreadsheet.**

Your staff review and recommendation form is needed as soon as possible. **Please use the new fillable form.** This form is to be used for your staff review.

A staff review must be completed for ALL **Bids/Proposals**. Please let me know if you need a copy of the fillable form.

**Please note:** If your project is being funded by any grants issued by the federal government, you must go to:  
<https://www.dol.gov/ofccp/regs/compliance/preaward/debarlist.htm> to ensure that the selected vendor has not been debarred.

**PLEASE NOTE:**

Results may be viewed next business day online EXCEPT when a bid is under review. The bidders/public will only see the names of the bidders that submitted a bid, not their cost. This will protect the bidders cost in case there is a re-bid.

**If you have any questions, please feel free to give me a call or send an email.**

Signature \_\_\_\_\_

cc: Shelbi Frayer





**SEALED PROPOSALS RECEIVED IN THE DIVISION OF PURCHASES & SUPPLIES**  
**For Hydrants, Grates and Manhole Covers – (2) Years**  
**PROPOSAL# 22000549**  
 Approximate Annual Quantities – Not Guaranteed  
 Furnish as requested for the period 7/1/21 – 6/30/23

<b>Vendor</b>	<b>Description</b>	<b>Total Year 1 - FY22</b>	<b>Total Year 2 - FY23</b>
Core & Main, LP Canton, MI	Grates & Manhole Covers	<b>\$2,430.57</b>	<b>\$2,430.57</b>
	Hydrants	<b>\$3,420.27</b>	<b>\$3,420.27</b>
EJ USA, Inc. East Jordan, MI	Grates & Manhole Covers	<b>\$2,347.06</b>	<b>\$2,402.95</b>
	Hydrants	<b>\$3,293.68</b>	<b>\$3,642.89</b>

**A SPECIAL NOTE FROM THE PURCHASING DIVISION**

*Bid results posted are before evaluation team review and award recommendation.*

**THIS PAGE INTENTIONALLY LEFT BLANK**

**BID NO. 22000549**  
**HYDRANTS, GRATES AND MANHOLE COVERS - (2) YEARS**

**THE FOLLOWING PAGES MUST BE COMPLETED AND INCLUDED WITH SUBMITTAL IN THE FOLLOWING ORDER.**

**Purchasing Checklist:**

- Cover Sheet
- Exhibit A - Complete Proposal Submittal with detailed Summary of Pricing
- Exhibit B - Qualifications and Licenses Requirements
- Exhibit C - Disclosure of Supplier Responsibility Statement
- Exhibit D - List of References
- Exhibit E - Certificate of Insurance
- Exhibit F - Non-Bidder's Response
- City of Flint, Michigan Affidavit

## ❖ EXHIBIT A - SUBMITTAL WITH DETAILED SUMMARY OF PRICING

**BID NO. 22000549**  
**HYDRANTS, GRATES AND MANHOLE COVERS - (2) YEARS**

**REQUIREMENTS/TABULATION**

Furnish as requested within 48 hours' notice beginning 7/1/2021 and ending 06/30/2023. Items shall be East Jordan Iron Works or approved equivalent. An hour delivery notification required for all shipments requiring the use of a fork lift. If notification is not made, the City reserves the right to refuse delivery at no additional cost to the City.

LN#	ITEM ID	DESCRIPTION	UOM	TOTAL YEAR 1 – FY22	TOTAL YEAR 2 – FY23
1	4000068010	Frame, Catch Basin, #700010	EA	231.29	231.29
2	4000070010	Grate, Regular, Catch Basin, #700030	EA	153.01	153.01
3	4000072010	Hood, Catch Basin, #700065	EA	156.09	156.09
4	4000069000	Grate, X.L., driveway, catch basin #7000M3 "DUMP NO WASTE!" DRAINS TO WATERWAYS (fish emblem)	EA	287.07	287.07
5	4000064000	Cover, open grate, manhole #107530 "DUMP NO WASTE! DRAINS TO WATERWAYS" (FISH EMBLEM)	EA	223.45	223.45
6	4000071000	Grate, State, Catch Basin	EA	140.28	140.28
8	4000070000	Grate, regular, catch basin	EA	153.01	153.01
9	4000075000	Frame, manhole #1075	EA	375.45	375.45
10		Sewer cover #1075	EA	207.77	207.77
11		MH cover, 1040-1 Z Frame Pressure Tight with 1040A solid cover pressure tight gasket seal, Flint sanitary sewer assembly to say "City of Flint" on same. 1040-1ZPT, 1040APTGS Flint SS ASY	EA	503.15	503.15
		<b>GRAND TOTAL UNIT PRICING</b>		\$ 2,430.57	\$ 2,430.57

Only the specifier has the responsibility and judgment for determining whether a proposed substitution is an "or equal or exceeding" specification. Mfg., model #, and supporting documentation of specifications for alternates must be provided.

All shipping and freight charges are to be included in the bid pricing.

Company Name: Core & Main LP

REQUIREMENTS/TABULATION

Furnish as requested within 48 hours' notice beginning 7/1/2021 and ending 06/30/2023. Hydrants must be East Jordan Iron Works SBR-250. 1 hour delivery notification required for all shipments requiring the use of a fork lift. If notification is not made, the City reserves the right to refuse delivery at no additional cost to the City.

LN#	ITEM ID	DESCRIPTION	UOM	TOTAL YEAR 1- FY22	TOTAL YEAR 2- FY23
		<b>FIRE HYDRANTS</b>			
1	8910065000	M.J. oversized 5'6", open right, 2-1/2" NS hose connections. 4-1/2" NS pumper, yellow, 7/8" sq. Hydrant must come with weep hole plugged	EA	2072.36	2072.36
		<b>B84-B</b>			
2	8800000000	6" EJW Hydrant Extension	EA	239.48	239.48
3	8800000000	12" EJW Hydrant Extension	EA	280.00	280.00
4	8800000000	18" EJW Hydrant Extension	EA	317.81	317.81
5	8800000000	24" EJW Hydrant Extension	EA	344.83	344.83
6		Hydrant Wrenches	EA	52.20	52.20
7		Food grade anti-seize 7lb can	EA	113.59	113.59
<b>GRAND TOTAL UNIT PRICING</b>				<b>\$ 3420.27</b>	<b>\$ 3420.27</b>

**PLEASE NOTE**

Only the specifier has the responsibility and judgment for determining whether a proposed substitution is an "or equal or exceeding" specification. Mfg., model #, and supporting documentation of specifications for alternates must be provided.

**All shipping and freight charges are to be included in the bid pricing.**

Company Name: Core & Main LP

All proposals will be evaluated on the following criteria:

P22000549 - HYDRANTS, GRATES AND MANHOLE COVERS - (2) YEARS



- 1. Failure to use this bid form shall result in bid disqualification.
- 2. Failure to bid on all items shall result in an "incomplete bid" determination.
- 3. List value-added considerations on a separate sheet of paper.
- 4. All bid pricing to include shipping and freight charges.

**THIS PAGE MUST BE COMPLETED AND INCLUDED WITH THE BID**

The undersigned hereby certifies, on behalf of the respondent named in this Certification (the "Respondent"), that the information provided in this offer submitted to the City of Flint, Department of Purchase and Supplies is accurate and complete, and that I am duly authorized to submit same. I hereby certify that the Respondent has reviewed all documents and requirements included in this offer and accept its terms and conditions.

Terms: Net 30

Fed. ID #: 03-0550887

Company (Respondent): Core & Main LP

Address: 6575 23 Mile Rd

City, State & Zip Code: Shelby Twp., MI 48316

Phone / Fax Number: 586-323-8800 FAX: 586-323-8812

Email: christopher.climie@coreandmain.com

Print Name and Title: Tom Fisher - District Manager

(Authorized Representative)

Signed: 

(Authorized Representative)

*THE QUALIFICATION of Core + Main LP is attached hereto and incorporated by reference as though fully set forth herein. T.F. 5/11/21*

❖ EXHIBIT B - QUALIFICATIONS AND LICENSES REQUIREMENTS

Please give a synopsis of your qualifications and experience with supplying HYDRANTS, GRATES AND MANHOLE COVERS:

COKE + MAW LP Stocks and Supplies EJ materials. COKE + MAW LP has won the hydrants, grates, + MH cover job with the City of Flint in the past.

Please list Licenses:

N/A

How long have you been in business?

Since 11-22-2004

Have you done business with the City of Flint?

YES

If yes, please state the project name.

Hydrant, GRATES, + Manhole Cover Castings @ WEC  
Bid # PI9-516

❖ EXHIBIT C – DISCLOSURE OF SUPPLIER RESPONSIBILITY STATEMENT

1. List any convictions of any person, subsidiary, or affiliate of the company, arising out of obtaining, or attempting to obtain a public or private contract, or subcontract, or in the performance of such contract or subcontract.

N/A

---

2. List any convictions of any person, subsidiary, or affiliate of this company for offenses such as embezzlement, theft, fraudulent schemes, etc. or any other offense indicating a lack of business integrity or business honesty which affect the responsibility of the contractor.

N/A

---

3. List any convictions or civil judgments under state or federal antitrust statutes.

N/A

---

4. List any violations of contract provisions such as knowingly (without good cause) to perform, or unsatisfactory performance, in accordance with the specifications of a contract.

N/A

---

5. List any prior suspensions or debarments by any government agency.

N/A

---

6. List any contracts not completed on time.

N/A

---

7. List any documented violations of federal or state labor laws, regulations or standards, or occupational safety and health rules.

N/A

---

---

**❖ EXHIBIT D – LIST OF REFERENCES: (3) SIMILAR SCOPE OF WORK FROM  
THE LAST 5 YEARS**

Providing the following contact information enables the City of Flint to contact those accounts as references.

**Reference #1:**

Company/Municipality: City of Madison Heights  
 Contact Person: Chris Woodward Title: Utilities Supervisor  
 Address: 801 Ajax Dr  
 City: Madison Heights State: MI Zip: 48071  
 Telephone: 248-229-5130 Fax: 248-589-2679  
 Email: chriswoodward@madison-heights.org  
 Type of Project: Watermain Municipal Bid

Project Timeline (Dates): May 2021-October 2021 Budget: \_\_\_\_\_

**Reference #2:**

Company/Municipality: City of Romulus  
 Contact Person: Garry Harris Title: Purchasing Director  
 Address: 12600 Wayne Rd  
 City: Romulus State: MI Zip: 48174  
 Telephone: 734-955-4568 Fax: 734-955-4526  
 Email: gharris@romulusgov.com  
 Type of Project: Municipal Bid

Project Timeline (Dates): June 2021-June 2023 Budget: \_\_\_\_\_

❖ EXHIBIT D – LIST OF REFERENCES: (3) SIMILAR SCOPE OF WORK FROM THE LAST 5 YEARS (CONTINUES)

Reference #3:

Company/Municipality: City of Ann Arbor

Contact Person: Dan Wooden Title: Supervisor

Address: 4251 Stoneschool Rd

City: Ann Arbor State: MI Zip: 48108

Telephone: 734-794-6320 Fax: \_\_\_\_\_

Email: DCWooden@a2gov.org

Type of Project: Municipal Bid

Project Timeline (Dates): 2020-2022 Budget: \_\_\_\_\_

**❖ EXHIBIT E – CERTIFICATE OF INSURANCE****INSURANCE REQUIREMENTS**

The Contractor shall notify all insurance agents and companies retained by the Contractor that these insurance requirements shall be included in any Agreement between the Contractor and the City of Flint.

The Contractor shall purchase and maintain, at its sole expense and as long as it is providing services to the City, the following insurance coverage:

Commercial General Liability - Occurrence form, including coverage for bodily injury, personal injury, property damage (broad form), premises/operations, blanket contractual, and products/completed operations. Coverage shall be endorsed to include the City as an additional insured for work performed by the Contractor in accordance with the Agreement.

**Minimum Limits:**

- \$1,000,000 per occurrence/\$2,000,000 general aggregate
- \$2,000,000 aggregate for products and completed operations
- \$1,000,000 personal and advertising injury

Automobile - Michigan "no-fault" coverage, and residual automobile liability, comprehensive form, covering owned, hired, and non-owned automobiles. Coverage shall be endorsed to include the City as an additional insured for work performed by the Contractor in accordance with the Agreement.

**Minimum Limits:**

- No-fault coverages - statutory
- \$500,000 per person/\$1,000,000 per accident - bodily injury
- \$500,000 per occurrence - property damage
- A combined single limit of \$1,000,000 per occurrence

Workers' Compensation and Employer's Liability- Statutory coverage or proof acceptable to the City of approval as a self-insurer by the State of Michigan.

**❖ EXHIBIT E – CERTIFICATE OF INSURANCE (CONTINUES)**

## Minimum Limits:

- Workers' Compensation - statutory
- Employer's Liability - \$100,000 each accident/\$100,000 disease - each employee
- \$500,000 disease - policy limit

Professional Liability – Covering acts, errors or omissions of a professional nature committed or alleged to have been committed by the Contractor or any of its subcontractors. Coverage shall be effective upon the date of the Agreement and shall remain effective for a period of three (3) years after the date of final payment thereunder. Such coverage shall be endorsed to include any subcontractors hired by the City.

## Minimum Limits:

- \$1,000,000 per occurrence, \$1,000,000 annual aggregate

Insurance coverage shall cover all claims against the City of Flint, its officials and employees, arising out of the work performed by the Contractor or any subcontractors under the Agreement. Should any work be subcontracted, it shall be the responsibility of the Contractor to maintain Independent Contractor's Protective Liability Insurance with limits equal to those specified above for Commercial General Liability Insurance. In addition, the Contractor shall provide proof of Workers' Compensation Insurance for all subcontractors in compliance with the required statutory limits of the State of Michigan.

Said policies of insurance shall be with companies licensed to do business in the State of Michigan and in a form satisfactory to the City. All insurance companies must maintain a rating of B+, VIII or better from AM. Best Company. Certificates of insurance with a thirty-(30) day cancellation clause shall be filed with and approved by the City at least five (5) days in advance of commencing work under the Agreement. Cancellation, material restriction, non-renewal or lapse of any of the required policies shall be grounds for immediate termination of the Agreement by the City.

The City reserves the right to request a complete certified copy of the policies for the above coverage's.

Any reduction or exhaustion in the limits of required insurance coverage shall not be deemed to limit the indemnification afforded in accordance with the Agreement or any amendments thereto.

Depending on the subject matter of the transaction, the City may require other insurance coverage in addition to the coverage's contained herein.

***THE BID NUMBER IS TO APPEAR ON ALL INSURANCE CERTIFICATES***

FOR PARTNERSHIP

STATE OF MICHIGAN

S.S.

COUNTY OF MALCOMB

Thomas B Fisher being duly sworn,  
deposes and says that they are a ~~member~~ <sup>REPRESENTATIVE</sup> of the firm of CORE AND MAIN LP, a co-  
partnership, making the above bid; that they are duly authorized to make said bid on behalf of said co-partnership;  
that said bid is genuine and not sham of collusive, and is not made in the interest of or on behalf of any person not  
therein named, and that they have and said bidder has not directly or indirectly induced or solicited any other  
person or corporation to refrain from bidding, and that they have not and said bidder has not in any manner  
sought by collusion to secure to themselves or to said bidder any advantage over other bidders.

Subscribed and sworn to before me at STUBBY TWP, in said County and State,

this 16<sup>th</sup> day of MAY, A.D. 20 21  
KST

\*Notary Public, MALCOMB County, MI

My Commission expires 03/13, 2026.

SIGNATURE: Thomas B Fisher





Qualifications to Bid of Core & Main LP  
Submitted to the City of Flint  
Proposal #22000549  
Hydrants, Grates and Manhole Covers - (2) Years

Notwithstanding anything contained in any bid or contract documents to the contrary, Core & Main LP, ("Core & Main") hereby qualifies its bids as follows. It is the express intention of the parties that, to the extent of the terms of this Qualification only, this Qualification shall supersede and control over the terms of the Bid Documents, Contract Documents and Specifications and any prior addenda thereto. Acceptance of any Agreement by Core & Main is made expressly conditioned on assent by the City of Flint ("Buyer") to the following additional or different terms:

1. Availability: Core & Main will use commercially reasonable efforts to deliver materials ordered within the time specified in the bid documents or the Agreement. Core & Main reserves the right to extend those delivery times based on manufacturer lead times as impacted events beyond the control of Core & Main including but not limited to the current pandemic, global shipping delays and resin shortage. Availability of materials is not guaranteed.
2. To the extent provided in its policy, Core & Main will only be able to provide a certificate of insurance, endorsements and coverage that are current form and meet industry standards subject to agreement by Core & Main's insurance provider. A Memorandum of Insurance is attached to demonstrate the level of coverage carried by Core & Main. To the extent permitted by its policy, Core & Main will name only the Buyer and its affiliates, subsidiaries, parents, officers and employees as additional insureds. Notice of cancellation will be provided by e-mail per state guidelines. General aggregate limits apply per policy. Core & Main will not be required to provide copies of its policies. Notwithstanding anything contained in any bid documents or contract documents to the contrary, by acceptance of Core & Main's bid, the Buyer accepts Core & Main's certificate of insurance in full compliance with all insurance requirements, including but not limited to notice provisions, coverage, language, policy limits, policy forms, and deductible amounts. The parties agree that Core & Main's insurance is provided on a contributory basis, and is primary, but only to the extent of the products, services, and operations of Core & Main.

Dated this   11   day of May, 2021.

CORE & MAIN LP

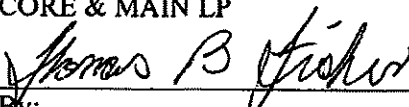
  
By: \_\_\_\_\_



# CERTIFICATE OF LIABILITY INSURANCE

DATE (MM/DD/YYYY)  
07/31/2020

THIS CERTIFICATE IS ISSUED AS A MATTER OF INFORMATION ONLY AND CONFERS NO RIGHTS UPON THE CERTIFICATE HOLDER. THIS CERTIFICATE DOES NOT AFFIRMATIVELY OR NEGATIVELY AMEND, EXTEND OR ALTER THE COVERAGE AFFORDED BY THE POLICIES BELOW. THIS CERTIFICATE OF INSURANCE DOES NOT CONSTITUTE A CONTRACT BETWEEN THE ISSUING INSURER(S), AUTHORIZED REPRESENTATIVE OR PRODUCER, AND THE CERTIFICATE HOLDER.

**IMPORTANT:** If the certificate holder is an ADDITIONAL INSURED, the policy(ies) must have ADDITIONAL INSURED provisions or be endorsed. If SUBROGATION IS WAIVED, subject to the terms and conditions of the policy, certain policies may require an endorsement. A statement on this certificate does not confer rights to the certificate holder in lieu of such endorsement(s).

<b>PRODUCER</b> Willis Towers Watson Northeast, Inc. c/o 26 Century Blvd P.O. Box 305191 Nashville, TN 372305191 USA	<b>CONTACT NAME:</b> Willis Towers Watson Certificate Center <b>PHONE (A/C No. Ext):</b> 1-877-945-7378 <b>FAX (A/C No):</b> 1-888-467-2378 <b>E-MAIL ADDRESS:</b> certificates@willis.com	
	<b>INSURER(S) AFFORDING COVERAGE</b>	
<b>INSURED</b> Core & Main LP 1830 Craig Park Court Saint Louis, MO 63146	<b>INSURER A:</b> National Union Fire Insurance Company of P <b>NAIC#</b> 19445	
	<b>INSURER B:</b> Willis Submission Carrier <b>GENRC</b>	
	<b>INSURER C:</b> XL Insurance America Inc <b>24554</b>	
	<b>INSURER D:</b>	
	<b>INSURER E:</b>	
<b>INSURER F:</b>		

**COVERAGES**      **CERTIFICATE NUMBER:** WL7434734      **REVISION NUMBER:**

THIS IS TO CERTIFY THAT THE POLICIES OF INSURANCE LISTED BELOW HAVE BEEN ISSUED TO THE INSURED NAMED ABOVE FOR THE POLICY PERIOD INDICATED. NOTWITHSTANDING ANY REQUIREMENT, TERM OR CONDITION OF ANY CONTRACT OR OTHER DOCUMENT WITH RESPECT TO WHICH THIS CERTIFICATE MAY BE ISSUED OR MAY PERTAIN, THE INSURANCE AFFORDED BY THE POLICIES DESCRIBED HEREIN IS SUBJECT TO ALL THE TERMS, EXCLUSIONS AND CONDITIONS OF SUCH POLICIES. LIMITS SHOWN MAY HAVE BEEN REDUCED BY PAID CLAIMS.

INSR LTR	TYPE OF INSURANCE	ADDL INSD	SUBR WVD	POLICY NUMBER	POLICY EFF (MM/DD/YYYY)	POLICY EXP (MM/DD/YYYY)	LIMITS
A	<input checked="" type="checkbox"/> <b>COMMERCIAL GENERAL LIABILITY</b> <input type="checkbox"/> CLAIMS-MADE <input checked="" type="checkbox"/> OCCUR <input checked="" type="checkbox"/> <b>SIR: \$500,000*</b> GENL AGGREGATE LIMIT APPLIES PER: <input type="checkbox"/> POLICY <input checked="" type="checkbox"/> PROJECT <input type="checkbox"/> LOC OTHER:			GL 1728964	08/01/2020	08/01/2021	EACH OCCURRENCE \$ 1,000,000 DAMAGE TO RENTED PREMISES (Ea occurrence) \$ 1,000,000 MED EXP (Any one person) \$ 15,000 PERSONAL & ADV INJURY \$ 1,000,000 GENERAL AGGREGATE \$ 2,000,000 PRODUCTS - COM/POP AGG \$ 2,000,000
B	<b>AUTOMOBILE LIABILITY</b> <input checked="" type="checkbox"/> ANY AUTO <input type="checkbox"/> OWNED AUTOS ONLY <input type="checkbox"/> SCHEDULED AUTOS <input type="checkbox"/> HIRED AUTOS ONLY <input type="checkbox"/> NON-OWNED AUTOS ONLY <input type="checkbox"/> OTHER:			SEE ATTACHED	08/01/2020	08/01/2021	COMBINED SINGLE LIMIT (Ea accident) \$ 2,000,000 BODILY INJURY (Per person) \$ BODILY INJURY (Per accident) \$ PROPERTY DAMAGE (Per accident) \$
C	<input checked="" type="checkbox"/> <b>UMBRELLA LIAB</b> <input checked="" type="checkbox"/> OCCUR <input type="checkbox"/> EXCESS LIAB <input type="checkbox"/> CLAIMS-MADE <input type="checkbox"/> DED <input checked="" type="checkbox"/> RETENTION \$ 10,000			US00093102LI20A	08/01/2020	08/01/2021	EACH OCCURRENCE \$ 5,000,000 AGGREGATE \$ 5,000,000
B	<b>WORKERS COMPENSATION AND EMPLOYERS' LIABILITY</b> ANY PROPRIETOR/PARTNER/EXECUTIVE OFFICER/MEMBER EXCLUDED? (Mandatory in NH) If yes, describe under DESCRIPTION OF OPERATIONS below Y/N    No    N/A			SEE ATTACHED	08/01/2020	08/01/2021	<input checked="" type="checkbox"/> PER STATUTE <input type="checkbox"/> OTHER E.L. EACH ACCIDENT \$ 1,000,000 E.L. DISEASE - EA EMPLOYEE \$ 1,000,000 E.L. DISEASE - POLICY LIMIT \$ 1,000,000
B	Additional Lines of Coverage			SEE ATTACHED	08/01/2020	08/01/2021	

DESCRIPTION OF OPERATIONS / LOCATIONS / VEHICLES (ACORD 101, Additional Remarks Schedule, may be attached if more space is required)  
\* General Liability: The \$1,000,000 per Occurrence and \$2,000,000 Aggregate limits displayed is a combination of \$500,000 Self-Insured Retention and \$500,000 Per Occurrence /\$1,500,000 Aggregate limits of liability provided by the carrier noted above.

<b>CERTIFICATE HOLDER</b>  Evidence of Insurance	<b>CANCELLATION</b> SHOULD ANY OF THE ABOVE DESCRIBED POLICIES BE CANCELLED BEFORE THE EXPIRATION DATE THEREOF, NOTICE WILL BE DELIVERED IN ACCORDANCE WITH THE POLICY PROVISIONS.
	<b>AUTHORIZED REPRESENTATIVE</b> 

## ADDITIONAL COVERAGE SCHEDULE

<b>AUTOMOBILE LIABILITY</b>		
Policy Effective & Expiration Dates: See Page 1		
Limits: See Page 1		
<b>POLICY NUMBER</b>	<b>STATE</b>	<b>INSURER(S) AFFORDING COVERAGE</b>
CA 4594395	All Other States	National Union Fire Insurance Company of Pittsburgh
CA 4594397	MA	National Union Fire Insurance Company of Pittsburgh
CA 4594396	VA	National Union Fire Insurance Company of Pittsburgh

<b>WORKERS COMPENSATION &amp; EMPLOYERS LIABILITY</b>		
Policy Effective & Expiration Dates: See Page 1 Limits:		
See Page 1		
<b>POLICY NUMBER</b>	<b>STATE</b>	<b>INSURER(S) AFFORDING COVERAGE</b>
WC 045886742	All Other States	New Hampshire Insurance Company
WC 045886743	CA	American Home Assurance Company
WC 045886745	MA, WI	New Hampshire Insurance Company
WC 045886744	FL	Illinois National Insurance Company

<b>EXCESS LIABILITY</b>			
Policy Effective & Expiration Dates: 08/01/2020-08/01/2021			
<b>POLICY NUMBER</b>	<b>TYPE OF INSURANCE</b>	<b>LIMITS</b>	<b>INSURER(S) AFFORDING COVERAGE</b>
MKLM6MM50000019	Excess General Liability	\$10,000,000 xs \$1,000,000 Primary	Markel Insurance Company
NY20RXS202HYLIV	Excess Automobile Liability	\$3,000,000 xs \$2,000,000 Primary	Navigators Insurance Company
42-XSF-308468-02	Excess Automobile Liability	\$5,000,000 xs \$5,000,000	Berkshire Hathaway Specialty Insurance Company

\*Umbrella Liability shown on Page 1 applies after above shown limits are exhausted for their respective lines of coverage

**THIS PAGE INTENTIONALLY LEFT BLANK**

**BID NO. 22000549**  
**HYDRANTS, GRATES AND MANHOLE COVERS - (2) YEARS**

**THE FOLLOWING PAGES MUST BE COMPLETED AND INCLUDED WITH SUBMITTAL IN THE FOLLOWING ORDER.**

**Purchasing Checklist:**

- Cover Sheet
- Exhibit A - Complete Proposal Submittal with detailed Summary of Pricing
- Exhibit B –Qualifications and Licenses Requirements
- Exhibit C – Disclosure of Supplier Responsibility Statement
- Exhibit D - List of References
- Exhibit E - Certificate of Insurance
- Exhibit F – Non-Bidder’s Response
- City of Flint, Michigan Affidavit

## ❖ EXHIBIT A - SUBMITTAL WITH DETAILED SUMMARY OF PRICING

**BID NO. 22000549**  
**HYDRANTS, GRATES AND MANHOLE COVERS - (2) YEARS**

**REQUIREMENTS/TABULATION**

Furnish as requested within 48 hours' notice beginning 7/1/2021 and ending 06/30/2023. Items shall be East Jordan Iron Works or approved equivalent. An hour delivery notification required for all shipments requiring the use of a fork lift. If notification is not made, the City reserves the right to refuse delivery at no additional cost to the City.

LN#	ITEM ID	DESCRIPTION	UOM	TOTAL YEAR 1 – FY22	TOTAL YEAR 2 – FY23
1	4000068010	Frame, Catch Basin, #700010	EA	223.34	228.66
2	4000070010	Grate, Regular, Catch Basin, #700030	EA	147.75	151.27
3	4000072010	Hood, Catch Basin, #700065	EA	150.72	154.31
4	4000069000	Grate, X.L., driveway, catch basin #7000M3 "DUMP NO WASTE!" DRAINS TO WATERWAYS (fish emblem)	EA	277.21	283.81
5	4000064000	Cover, open grate, manhole #107530 "DUMP NO WASTE! DRAINS TO WATERWAYS" (FISH EMBLEM)	EA	215.77	220.91
6	4000071000	Grate, State, Catch Basin	EA	135.46	138.68
8	4000070000	Grate, regular, catch basin	EA	147.75	151.27
9	4000075000	Frame, manhole #1075	EA	362.56	371.19
10		Sewer cover #1075	EA	200.63	205.41
11		MH cover, 1040-1 Z Frame Pressure Tight with 1040A solid cover pressure tight gasket seal, Flint sanitary sewer assembly to say "City of Flint" on same. 1040-1ZPT, 1040APTGS Flint SS ASY	EA	485.87	497.44
<b>GRAND TOTAL UNIT PRICING</b>				<b>\$ 2,347.06</b>	<b>\$ 2,402.95</b>

Only the specifier has the responsibility and judgment for determining whether a proposed substitution is an "or equal or exceeding" specification. Mfg., model #, and supporting documentation of specifications for alternates must be provided.

All shipping and freight charges are to be included in the bid pricing.

Company Name: EJ USA, Inc.

**REQUIREMENTS/TABULATION**

Furnish as requested within 48 hours' notice beginning 7/1/2021 and ending 06/30/2023. Hydrants must be East Jordan Iron Works 5BR-250. **1 hour delivery notification required for all shipments requiring the use of a fork lift. If notification is not made, the City reserves the right to refuse delivery at no additional cost to the City.**

LN#	ITEM ID	DESCRIPTION	UOM	TOTAL YEAR 1- FY22	TOTAL YEAR 2- FY23
		<b>FIRE HYDRANTS</b>			
1	8910065000	M.J. oversized 5'6", open right, 2-1/2" NS	EA	1,985.32	2,021.42
		hose connections. 4-1/2" NS pumper, yellow, 7/8" sq. Hydrant must come with weep hole plugged			
		<b>B84-B</b>			
2	8800000000	6" EJW Hydrant Extension	EA	234.48	235.54
3	8800000000	12" EJW Hydrant Extension	EA	271.81	275.39
4	8800000000	18" EJW Hydrant Extension	EA	308.52	312.58
5	8800000000	24" EJW Hydrant Extension	EA	334.74	339.15
6		Hydrant Wrenches	EA	50.00	50.00
7		Food grade anti-seize 7lb can	EA	108.81	108.81
<b>GRAND TOTAL UNIT PRICING</b>				<b>\$ 3,293.68</b>	<b>\$ 3,642.89</b>

**PLEASE NOTE**

Only the specifier has the responsibility and judgment for determining whether a proposed substitution is an "or equal or exceeding" specification. Mfg., model #, and supporting documentation of specifications for alternates must be provided.

**All shipping and freight charges are to be included in the bid pricing.**

Company Name: EJ USA, Inc.

**All proposals will be evaluated on the following criteria:**

P22000549 – HYDRANTS, GRATES AND MANHOLE COVERS – (2) YEARS

1. Failure to use this bid form shall result in bid disqualification.
2. Failure to bid on all items shall result in an "incomplete bid" determination.
3. List value-added considerations on a separate sheet of paper.
4. All bid pricing to include shipping and freight charges.

**THIS PAGE MUST BE COMPLETED AND INCLUDED WITH THE BID**

The undersigned hereby certifies, on behalf of the respondent named in this Certification (the "Respondent"), that the information provided in this offer submitted to the City of Flint, Department of Purchase and Supplies is accurate and complete, and that I am duly authorized to submit same. I hereby certify that the Respondent has reviewed all documents and requirements included in this offer and accept its terms and conditions.

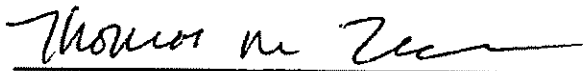
Terms: 0 Net 30Fed. ID #: 38-1434427Company (Respondent): EJ USA, Inc.Address: 301 Spring Street, PO Box 439City, State & Zip Code: East Jordan, MI 49727Phone / Fax Number: 1-800-874-4100 FAX: 231-536-4458Email: us.bids@ejco.comPrint Name and Title: Thomas M. Teske, Vice President & General Manager  
(Authorized Representative)Signed:   
(Authorized Representative)



**❖ EXHIBIT B - QUALIFICATIONS AND LICENSES REQUIREMENTS****Please give a synopsis of your qualifications and experience with supplying HYDRANTS, GRATES AND MANHOLE COVERS:**

EJ is the global leader in the design, manufacture, and distribution of access solutions for the world's growing infrastructure. From water and sewer, to drainage, telecommunication, and utility projects, EJ has the solution to fit your project's needs.

The EJ legacy dates back to 1883 when our first manufacturing facility was built in East Jordan, Michigan, USA. Decades later, we are now a global enterprise that spans six continents – promoting innovation, quality, and a commitment to customer service.

**Please list Licenses:**

800294507

**How long have you been in business?**

138 Years

**Have you done business with the City of Flint?**

Yes

**If yes, please state the project name.**

Hydrant Stems

❖ EXHIBIT C – DISCLOSURE OF SUPPLIER RESPONSIBILITY STATEMENT

1. List any convictions of any person, subsidiary, or affiliate of the company, arising out of obtaining, or attempting to obtain a public or private contract, or subcontract, or in the performance of such contract or subcontract.

N/A

---

2. List any convictions of any person, subsidiary, or affiliate of this company for offenses such as embezzlement, theft, fraudulent schemes, etc. or any other offense indicating a lack of business integrity or business honesty which affect the responsibility of the contractor.

N/A

---

3. List any convictions or civil judgments under state or federal antitrust statutes.

N/A

---

4. List any violations of contract provisions such as knowingly (without good cause) to perform, or unsatisfactory performance, in accordance with the specifications of a contract.

N/A

---

5. List any prior suspensions or debarments by any government agency.

N/A

---

6. List any contracts not completed on time.

N/A

---

7. List any documented violations of federal or state labor laws, regulations or standards, or occupational safety and health rules.

N/A

---

---

❖ EXHIBIT D – LIST OF REFERENCES: (3) SIMILAR SCOPE OF WORK FROM THE LAST 5 YEARS

\*\*\*See Attached Sheet

Providing the following contact information enables the City of Flint to contact those accounts as references.

**Reference #1:**

Company/Municipality: \_\_\_\_\_

Contact Person: \_\_\_\_\_ Title: \_\_\_\_\_

Address: \_\_\_\_\_

City: \_\_\_\_\_ State: \_\_\_\_\_ Zip: \_\_\_\_\_

Telephone: \_\_\_\_\_ Fax: \_\_\_\_\_

Email: \_\_\_\_\_

Type of Project: \_\_\_\_\_

Project Timeline (Dates): \_\_\_\_\_ Budget: \_\_\_\_\_

**Reference #2:**

Company/Municipality: \_\_\_\_\_

Contact Person: \_\_\_\_\_ Title: \_\_\_\_\_

Address: \_\_\_\_\_

City: \_\_\_\_\_ State: \_\_\_\_\_ Zip: \_\_\_\_\_

Telephone: \_\_\_\_\_ Fax: \_\_\_\_\_

Email: \_\_\_\_\_

Type of Project: \_\_\_\_\_

Project Timeline (Dates): \_\_\_\_\_ Budget: \_\_\_\_\_

❖ EXHIBIT D – LIST OF REFERENCES: (3) SIMILAR SCOPE OF WORK FROM  
THE LAST 5 YEARS (CONTINUES)

Reference #3:

Company/Municipality: \_\_\_\_\_

Contact Person: \_\_\_\_\_ Title: \_\_\_\_\_

Address: \_\_\_\_\_

City: \_\_\_\_\_ State: \_\_\_\_\_ Zip: \_\_\_\_\_

Telephone: \_\_\_\_\_ Fax: \_\_\_\_\_

Email: \_\_\_\_\_

Type of Project: \_\_\_\_\_

Project Timeline (Dates): \_\_\_\_\_ Budget: \_\_\_\_\_



## References

### City of Chicago

Agency/Owner: City of Chicago  
Contract Number: 115944  
Goods Provided: Chicago Hydrant and Hydrant Parts  
Name & Location: City of Chicago, IL  
Prime Contractor: EJ USA, Inc  
Start/Completion: 12/10/2013-12/9/2018  
Contract Amount: \$12,971,797  
Contact: Barbara Lumpkin, Chief Procurement Officer, 312-744-4900

### City of Chicago

Agency/Owner: City of Chicago  
Contract Number: 124843  
Goods Provided: Manhole/Catch Basin Frames, Lids  
Name & Location: City of Chicago, IL  
Start/Completion: 3/12/2015-3/11/2020  
Contract Amount: \$6,571,278  
Contact: Barbara Lumpkin, Chief Procurement Officer, 312-744-4900

### City of Chicago

Agency/Owner: City of Chicago  
Contract Number: 115734A  
Goods Provided: Chicago Standard Gate Valves and Parts  
Name & Location: City of Chicago, IL  
Start/Completion: 8/18/2015-8/17/2020  
Contract Amount: \$9,965,337  
Contact: Barbara Lumpkin, Chief Procurement Officer, 312-744-4900

### Massachusetts Department of Transportation

Agency/Owner: MassDOT  
Contract Number: 85599  
Goods Provided: Water Products and Maintenance Services  
Name & Location: MassDOT, Boston MA  
Start/Completion: 4/2/2015-4/1/2020  
Contract Amount: \$4,500,000  
Contact: Max Feldpausch, Purchaser, 857-368-9139

### Pittsburgh Water and Sewer Authority

Agency/Owner: City of Pittsburgh  
Contract Number: PWSA7  
Goods Provided: Water & Sewer Inventory Supplies  
Name & Location: City of Pittsburgh, PA  
Prime Contractor: EJ USA, Inc  
Start/Completion: 5/3/2014-5/2/2018  
Contract Amount: \$614,608  
Contact: Autumn Barna, Contract/Procurement Specialist, 412-255-8800

**❖ EXHIBIT E – CERTIFICATE OF INSURANCE****INSURANCE REQUIREMENTS**

The Contractor shall notify all insurance agents and companies retained by the Contractor that these insurance requirements shall be included in any Agreement between the Contractor and the City of Flint.

The Contractor shall purchase and maintain, at its sole expense and as long as it is providing services to the City, the following insurance coverage:

Commercial General Liability - Occurrence form, including coverage for bodily injury, personal injury, property damage (broad form), premises/operations, blanket contractual, and products/completed operations. Coverage shall be endorsed to include the City as an additional insured for work performed by the Contractor in accordance with the Agreement.

**Minimum Limits:**

- \$1,000,000 per occurrence/\$2,000,000 general aggregate
- \$2,000,000 aggregate for products and completed operations
- \$1,000,000 personal and advertising injury

Automobile - Michigan "no-fault" coverage, and residual automobile liability, comprehensive form, covering owned, hired, and non-owned automobiles. Coverage shall be endorsed to include the City as an additional insured for work performed by the Contractor in accordance with the Agreement.

**Minimum Limits:**

- No-fault coverages - statutory
- \$500,000 per person/\$1,000,000 per accident - bodily injury
- \$500,000 per occurrence - property damage
- A combined single limit of \$1,000,000 per occurrence

Workers' Compensation and Employer's Liability- Statutory coverage or proof acceptable to the City of approval as a self-insurer by the State of Michigan.

**❖ EXHIBIT E – CERTIFICATE OF INSURANCE (CONTINUES)**

## Minimum Limits:

- Workers' Compensation - statutory
- Employer's Liability - \$100,000 each accident/\$100,000 disease - each employee
- \$500,000 disease - policy limit

Professional Liability – Covering acts, errors or omissions of a professional nature committed or alleged to have been committed by the Contractor or any of its subcontractors. Coverage shall be effective upon the date of the Agreement and shall remain effective for a period of three (3) years after the date of final payment thereunder. Such coverage shall be endorsed to include any subcontractors hired by the City.

## Minimum Limits:

- \$1,000,000 per occurrence, \$1,000,000 annual aggregate

Insurance coverage shall cover all claims against the City of Flint, its officials and employees, arising out of the work performed by the Contractor or any subcontractors under the Agreement. Should any work be subcontracted, it shall be the responsibility of the Contractor to maintain Independent Contractor's Protective Liability Insurance with limits equal to those specified above for Commercial General Liability Insurance. In addition, the Contractor shall provide proof of Workers' Compensation Insurance for all subcontractors in compliance with the required statutory limits of the State of Michigan.

Said policies of insurance shall be with companies licensed to do business in the State of Michigan and in a form satisfactory to the City. All insurance companies must maintain a rating of B+, VIII or better from AM. Best Company. Certificates of insurance with a thirty-(30) day cancellation clause shall be filed with and approved by the City at least five (5) days in advance of commencing work under the Agreement. Cancellation, material restriction, non-renewal or lapse of any of the required policies shall be grounds for immediate termination of the Agreement by the City.

The City reserves the right to request a complete certified copy of the policies for the above coverage's.

Any reduction or exhaustion in the limits of required insurance coverage shall not be deemed to limit the indemnification afforded in accordance with the Agreement or any amendments thereto.

Depending on the subject matter of the transaction, the City may require other insurance coverage in addition to the coverage's contained herein.

***THE BID NUMBER IS TO APPEAR ON ALL INSURANCE CERTIFICATES***

FOR CORPORATION

STATE OF Michigan

S.S.

COUNTY OF Charlevoix

Thomas M. Teske being duly sworn, deposes and says that she/he/they  
is Vice President & General Manager of EJ USA, Inc.

(Official Title)

(Name of Corporation)

a corporation duly organized and doing business under the laws of the State of Michigan  
the corporation making the within and foregoing bid; that they executed said bid in behalf of said corporation by  
authority of its Board of Directors; that said bid is genuine and not sham or collusive and is not made in the  
interests of or on behalf of any person not herein named, and that they have not and said bidder has not directly  
or indirectly induced or solicited any other person or corporation to refrain from bidding; that they have not and  
said bidder has not in any manner sought by collusion to secure to themselves or to said corporation an advantage  
over other bidders.

Subscribed and sworn to before me at East Jordan, in said County and State,

this 10th day of May, A.D. 20 21



\*Notary Public, State of Michigan County, Emmet

My Commission expires May 29, 20 23

RACHEL L. JOHNSON  
NOTARY PUBLIC - STATE OF MICHIGAN  
COUNTY OF EMMET  
MY COMMISSION EXPIRES 5/29/2023  
ACTING IN THE COUNTY OF Charlevoix





RESOLUTION NO.: 210263  
 PRESENTED: JUN - 6 2021  
 ADOPTED: \_\_\_\_\_

PROPOSAL# 21000605

BY THE CITY ADMINISTRATOR:

**RESOLUTION TO REPUBLIC SERVICES FOR SEWAGE SLUDGE CAKE DISPOSAL**

WHEREAS, Water Pollution Control (WPC) generates approximately 13,000 wet tons of biosolids cake and grit (“residuals”) from its wastewater treatment process annually. Residuals must be transported off plant site to a landfill or other disposal site every weekday. The services are to be provided with fixed rates, for a period of three fiscal years. The contracts will be in effect for FY2022, FY2023, and FY2024. Three bids were reviewed and a split award is recommended.

WPC recommends the lowest qualified bidder, Republic Services be awarded the bid for disposal (landfill) services in the amount of \$247,000 for FY2022, \$260,000 for FY2023, and \$273,000 for FY2024, totaling \$780,000.

Account Number	Account Name	Amount
590-550.100-801.500	Sludge Disposal Services	\$247,000.00
	<b>FY2022 GRAND TOTAL</b>	<b>\$247,000.00</b>

IT IS RESOLVED, that the appropriate City Officials are authorized to do all things necessary to enter into a contract with Republic Services to provide sewage sludge cake disposal services for FY2022, pending budget adoption, for the amount of \$247,000.00.

APPROVED AS TO FORM:

Angela Wheeler  
Angela Wheeler (May 24, 2021 09:41 EDT)  
 Angela Wheeler, Chief Legal Officer

APPROVED AS TO FINANCE:

Shelbi Frayer  
shelbi frayer (May 24, 2021 10:29 EDT)  
 Shelbi Frayer, Chief Financial Officer

FOR THE CITY OF FLINT:

Clyde D. Edwards  
Clyde D Edwards (May 24, 2021 14:43 EDT)  
 Clyde Edwards, City Administrator

APPROVED BY CITY COUNCIL:

\_\_\_\_\_  
 Kate Fields, City Council President

APPROVED AS TO PURCHASING:

Jennifer Ryan  
Jennifer Ryan (May 21, 2021 15:22 EDT)  
 Jenn Ryan, Deputy Finance Director



# CITY OF FLINT

## RESOLUTION STAFF REVIEW FORM

**TODAY'S DATE:** 03/12/2021

**BID/PROPOSAL#:** Proposal 21000605

**AGENDA ITEM TITLE:** Sewage Sludge Cake Disposal and Transport Services

**PREPARED BY:** Krystal Wallace  
Water Pollution Control

**VENDOR NAME:** Republic Services for Cake Disposal  
DHT Transportation for Transport Services

### BACKGROUND/SUMMARY OF PROPOSED ACTION:

Water Pollution Control (WPC) generates approximately 13,000 wet tons of biosolids cake and grit ("residuals") from its wastewater treatment process annually. Residuals must be transported off plant site to a landfill or other disposal site every weekday. The services are to be provided with fixed rates, for a period of three fiscal years. The Contracts will be in effect for FY2022, FY2023, and FY2024. Three Bids were reviewed and a split award is recommended.

WPC recommends the lowest qualified bidder; DHT Transportation be awarded the bid for transportation services in the amount of \$250,000.00 for each of the next three fiscal years, FY 2022, 2023, & 2024, a three-(3) year total of \$750,000.00.

WPC also recommends the lowest qualified bidder; Republic Services be awarded the three year bid for Disposal Services (Landfill) services in the amount of \$247,000.00 (FY 2022), \$260,000.00 (FY2023), and \$273,000.00 (FY 2024), a three-(3) year total of \$780,000.00.

Amounts are pending approval and adoption of each respective fiscal year.

**FINANCIAL IMPLICATIONS:** None

**BUDGETED EXPENDITURE?** YES  NO  IF NO, PLEASE EXPLAIN:

Dept.	Name of Account	Account Number	Grant Code	Amount
DPW-WPC	Sludge Disposal Services	590-550.100-801.500		\$250,000.00
DPW-WPC	Sludge Disposal Services	590-550.100-801.500		\$247,000.00
<b>FY2022 GRAND TOTAL</b>				<b>\$497,000.00</b>



**CITY OF FLINT**

**PRE-ENCUMBERED?** YES  NO  **REQUISITION NO:** 210004067 and 210004503

**ACCOUNTING APPROVAL:** \_\_\_\_\_ **Date:** \_\_\_\_\_

**WILL YOUR DEPARTMENT NEED A CONTRACT?** YES  NO   
*(If yes, please indicate how many years for the contract)* YEARS

**WHEN APPLICABLE, IF MORE THAN ONE (1) YEAR, PLEASE ESTIMATE TOTAL AMOUNT FOR EACH BUDGET YEAR: (This will depend on the term of the bid proposal)**

**Transport Disposal**  
**BUDGET YEAR 1** \$250,000.00 & \$247,000.00

**BUDGET YEAR 2** \$250,000.00 & \$260,000.00

**BUDGET YEAR 3** \$250,000.00 & \$273,000.00

**OTHER IMPLICATIONS (i.e., collective bargaining):** None.

**STAFF RECOMMENDATION: (PLEASE SELECT):**  **APPROVED**  **NOT APPROVED**

**DEPARTMENT HEAD SIGNATURE:** \_\_\_\_\_  
*Jeanette H. Best*  
**(Jeanette Best, WPC Manager)**

Waste Management				
Landfill (Sludge Disposal)	YEAR 1 7/1/21 to 6/30/22	YEAR 2 7/1/22 to 6/30/23	YEAR 3 7/1/23 to 6/30/24	
Hours of Operation	Total cost per ton	Total cost per ton	Total cost per ton	Total cost per ton
Monday thru Friday	\$ 38.50	\$ 40.40	\$ 42.43	
Saturday	Closed	Closed	Closed	
Holidays	Closed	Closed	Closed	
<b>TOTAL COST</b>	<b>\$ 509,500.00</b>	<b>\$ 525,200.00</b>	<b>\$ 651,600.00</b>	
13,000 Tons per fiscal year				

Republic Services				
Landfill (Sludge Disposal)	YEAR 1 7/1/21 to 6/30/22	YEAR 2 7/1/22 to 6/30/23	YEAR 3 7/1/23 to 6/30/24	
Hours of Operation	Total cost per ton	Total cost per ton	Total cost per ton	Total cost per ton
Monday thru Friday	\$ 19.00	\$ 20.00	\$ 21.00	
Saturday	\$ 19.00	\$ 20.00	\$ 21.00	
Holidays	\$ 30.00	\$ 32.00	\$ 33.00	
<b>TOTAL COST</b>	<b>\$ 247,000.00</b>	<b>\$ 260,800.00</b>	<b>\$ 273,900.00</b>	
13,000 Tons per fiscal year				

DHT Transport Services				
Landfill (Sludge Disposal)	YEAR 1 7/1/21 to 6/30/22	YEAR 2 7/1/22 to 6/30/23	YEAR 3 7/1/23 to 6/30/24	
Hours of Operation	Total cost per ton	Total cost per ton	Total cost per ton	Total cost per ton
Monday thru Friday	\$	\$	\$	
Saturday	\$	\$	\$	
Holidays	\$	\$	\$	
<b>TOTAL COST</b>	<b>No Bid</b>	<b>No Bid</b>	<b>No Bid</b>	
13,000 Tons per fiscal year				

Transport to Landfill	Republic Citizens Grand Blanc	Brent Run Memrose	Venice Park Lenon	Waste Management Birch Run
LOCATION	2381 W Grand Blanc RD Grand Blanc MI 48438	8335 Vienna RD Monroeville MI 48457	9038 E Lenon RD Lenon MI 48448	4143 East Rambou RD Birch Run MI 48415
DISTANCE, Miles	10.2	15	13.8	21.3
Travel Time	12 minutes	17 minutes	19 minutes	28 minutes
<b>Cost per ton, per mile</b>				
FISCAL Year	General rate			
FY 22	N/A	No Bid	No Bid	No Bid
FY 23	N/A	No Bid	No Bid	No Bid
FY 24	N/A	No Bid	No Bid	No Bid

Transport to Landfill	Republic Citizens Grand Blanc	Brent Run Memrose	Venice Park Lenon	Waste Management Birch Run
LOCATION	2381 W Grand Blanc RD Grand Blanc MI 48438	8335 Vienna RD Monroeville MI 48457	9038 E Lenon RD Lenon MI 48448	4143 East Rambou RD Birch Run MI 48415
DISTANCE, Miles	10.2	15	13.8	21.3
Travel Time	12 minutes	17 minutes	19 minutes	28 minutes
<b>Cost per ton, per mile</b>				
FISCAL Year	General rate			
FY 22	N/A	No Bid	No Bid	No Bid
FY 23	N/A	No Bid	No Bid	No Bid
FY 24	N/A	No Bid	No Bid	No Bid

Transport to Landfill	Republic Citizens Grand Blanc	Brent Run Memrose	Venice Park Lenon	Waste Management Birch Run
LOCATION	2381 W Grand Blanc RD Grand Blanc MI 48438	8335 Vienna RD Monroeville MI 48457	9038 E Lenon RD Lenon MI 48448	4143 East Rambou RD Birch Run MI 48415
DISTANCE, Miles	10.3	16	13.8	21.3
Travel Time	12 minutes	17 minutes	19 minutes	28 minutes
<b>Cost per ton, per mile</b>				
FISCAL Year	General rate			
FY 22	N/A	\$ 455.00	\$ 455.00	\$ 500.00
FY 23	N/A	\$ 466.38	\$ 466.38	\$ 512.50
FY 24	N/A	\$ 478.04	\$ 478.04	\$ 525.31

Summary				
Vendor	Fiscal Year	Landfill	Sludge Transportation (Residue)	Waste Management
DHT Transportation	FY 2022	No Bid	\$ 455.00	\$ 286,000.00
	FY 2023	No Bid	\$ 466.38	\$ 242,517.40
	FY 2024	No Bid	\$ 478.04	\$ 248,580.80
Republic Services	FY 2022	\$ 247,000.00	\$ 475.00	\$ 247,000.00
	FY 2023	\$ 260,800.00	\$ 490.00	\$ 254,800.00
	FY 2024	\$ 273,900.00	\$ 500.00	\$ 260,000.00
Waste Management	FY 2022	\$ 500,500.00	No Bid	No Bid
	FY 2023	\$ 525,200.00	No Bid	No Bid
	FY 2024	\$ 651,600.00	No Bid	No Bid

Summary				
Vendor	Fiscal Year	Landfill	Sludge Transportation (Residue)	Waste Management
DHT Transportation	FY 2022	No Bid	\$ 455.00	\$ 286,000.00
	FY 2023	No Bid	\$ 466.38	\$ 242,517.40
	FY 2024	No Bid	\$ 478.04	\$ 248,580.80
Republic Services	FY 2022	\$ 247,000.00	\$ 475.00	\$ 247,000.00
	FY 2023	\$ 260,800.00	\$ 490.00	\$ 254,800.00
	FY 2024	\$ 273,900.00	\$ 500.00	\$ 260,000.00
Waste Management	FY 2022	\$ 500,500.00	No Bid	No Bid
	FY 2023	\$ 525,200.00	No Bid	No Bid
	FY 2024	\$ 651,600.00	No Bid	No Bid

Summary				
Vendor	Fiscal Year	Landfill	Sludge Transportation (Residue)	Waste Management
DHT Transportation	FY 2022	No Bid	\$ 455.00	\$ 286,000.00
	FY 2023	No Bid	\$ 466.38	\$ 242,517.40
	FY 2024	No Bid	\$ 478.04	\$ 248,580.80
Republic Services	FY 2022	\$ 247,000.00	\$ 475.00	\$ 247,000.00
	FY 2023	\$ 260,800.00	\$ 490.00	\$ 254,800.00
	FY 2024	\$ 273,900.00	\$ 500.00	\$ 260,000.00
Waste Management	FY 2022	\$ 500,500.00	No Bid	No Bid
	FY 2023	\$ 525,200.00	No Bid	No Bid
	FY 2024	\$ 651,600.00	No Bid	No Bid

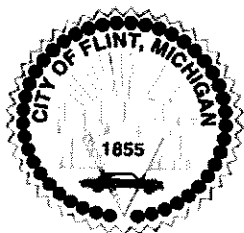

**City of Flint**  
**Department of Finance**  
**Division of Purchases & Supplies**

---

Sheldon A. Neeley

March 25, 2021

**TO:** Michael Brown  
Jeanette Best

**FROM:** Joyce A. McClane  
Purchasing Manager

**SUBJECT:** SEALED BIDS

Attached are three (3) bids that were received for **PROPOSAL #21000605 – SEWAGE SLUDGE CAKE DISPOSAL AND TRANSPORT SERVICES**. Enclosed are copies for your file. **Bid Due Date: 3/24/21. Enclosed is a spreadsheet.**

Your staff review and recommendation form is needed as soon as possible. **Please use the new fillable form.** This form is to be used for your staff review.

A staff review must be completed for **ALL Bids/Proposals**. Please let me know if you need a copy of the fillable form.

**Please note:** If your project is being funded by any grants issued by the federal government, you must go to:  
<https://www.dol.gov/ofccp/regs/compliance/preaward/debarlst.htm> to ensure that the selected vendor has not been debarred.

**PLEASE NOTE:**

Results may be viewed next business day online **EXCEPT** when a bid is under review. The bidders/public will only see the names of the bidders that submitted a bid, not their cost. This will protect the bidders cost in case there is a re-bid.

**If you have any questions, please feel free to give me a call or send an email.**

  
Signature

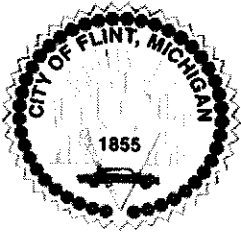

# City of Flint

## Department of Finance Division of Purchases & Supplies

---

Sheldon A. Neeley

Today's Date:

Please complete the following form if you decide to rebid:

**Proposal #**

**DETAILED REASON FOR WANTING TO REBID:**

**Authorized Signature and Title:**

**Date Signed**

.....  
**PURCHASING USE ONLY**



**SEALED PROPOSALS RECEIVED IN THE DIVISION OF PURCHASES & SUPPLIES**  
**For Sewage Sludge Cake Disposal & Transport Services**  
**PROPOSAL# 21000605**

Approximate Annual Quantities – Not Guaranteed  
 Furnish as requested for the period 7/1/20 – 6/30/21

## Biosolids (Landfill) Disposal Contract

### BID FORM

**Bidder #1: DHT Transport**  
**2695 W. Vassar Rd., Reese, MI 48757**

Landfill (Sludge Disposal) Hours of Operation		YEAR 1 7/1/21 to 6/30/22	YEAR 2 7/1/22 to 6/30/23	YEAR 3 7/1/23 to 6/30/24
		Total cost per ton	Total cost per ton	Total cost per ton
Monday thru Friday		\$ No Bid	\$ No Bid	\$ No Bid
Saturday		\$ No Bid	\$ No Bid	\$ No Bid
Holidays		\$ No Bid	\$ No Bid	\$ No Bid
<b>TOTAL COST</b> 13,000 Tons per fiscal year		\$ No Bid	\$ No Bid	\$ No Bid

**A SPECIAL NOTE FROM THE PURCHASING DIVISION**

*Bid results posted are before evaluation team review and award recommendation.*



**Biosolids Transportation Contract  
YEAR 1 BID FORM**

**July 1, 2022 to June 30, 2023**

<b>LANDFILL</b>	<b>Republic Citizens Grand Blanc</b>	<b>Brent Run Montrose</b>	<b>Venice Park Lennon</b>	<b>Waste Management Birch Run</b>
<b>LOCATION</b>	2361 W Grand Blanc RD Grand Blanc MI 48439	8335 Vienna RD Montrose MI 48457	9536 E Lennon RD Lennon MI 48449	4143 East Rathbun RD Birch Run, MI 48415
<b>DISTANCE, Miles Travel Time</b>	<b>10.2</b> 12 minutes	<b>15.0</b> 17 minutes	<b>13.8</b> 19 minutes	<b>21.3</b> 29 minutes
<b>Cost per ton, per mile General rate</b>	<b>Cost per ton Trailer</b>			
\$ N/A	\$ 455.00	\$ 455.00	\$ 455.00	\$ 500.00

**Biosolids Transportation Contract  
YEAR 2 BID FORM**

**July 1, 2023 to June 30, 2024**

<b>LANDFILL</b>	<b>Republic Citizens Grand Blanc</b>	<b>Brent Run Montrose</b>	<b>Venice Park Lennon</b>	<b>Waste Management Birch Run</b>
<b>LOCATION</b>	2361 W Grand Blanc RD Grand Blanc MI 48439	8335 Vienna RD Montrose MI 48457	9536 E Lennon RD Lennon MI 48449	4143 East Rathbun RD Birch Run, MI 48415
<b>DISTANCE, Miles Travel Time</b>	<b>10.2</b> 12 minutes	<b>15.0</b> 17 minutes	<b>13.8</b> 19 minutes	<b>21.3</b> 29 minutes
<b>Cost per ton, per mile General rate</b>	<b>Cost per ton Trailer</b>			
\$ N/A	\$ 466.38	\$ 466.38	\$ 466.38	\$ 512.50

**A SPECIAL NOTE FROM THE PURCHASING DIVISION**

*Bid results posted are before evaluation team review and award recommendation.*



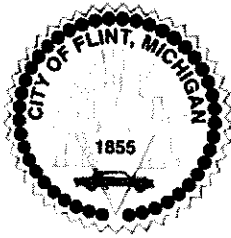

**Biosolids Transportation Contract  
YEAR 3 BID FORM**

**July 1, 2023 to June 30, 2024**

<b>LANDFILL</b>	<b>Republic Citizens Grand Blanc</b>	<b>Brent Run Montrose</b>	<b>Venice Park Lennon</b>	<b>Waste Management Birch Run</b>
<b>LOCATION</b>	2361 W Grand Blanc RD Grand Blanc MI 48439	8335 Vienna RD Montrose MI 48457	9536 E Lennon RD Lennon MI 48449	4143 East Rathbun RD Birch Run, MI 48415
<b>DISTANCE, Miles Travel Time</b>	<b>10.2</b> 12 minutes	<b>15.0</b> 17 minutes	<b>13.8</b> 19 minutes	<b>21.3</b> 29 minutes
<b>Cost per ton, per mile General rate</b>	<b>Cost per ton Trailer</b>			
\$ N/A	\$ 478.04	\$ 478.04	\$ 478.04	\$ 525.31

**A SPECIAL NOTE FROM THE PURCHASING DIVISION**

*Bid results posted are before evaluation team review and award recommendation.*



## Biosolids (Landfill) Disposal Contract

### BID FORM

**Bidder #2: Republic Services of Flint**  
**4101 Holiday Drive, Flint, MI 48507**

Landfill (Sludge Disposal) Hours of Operation		YEAR 1 7/1/21 to 6/30/22	YEAR 2 7/1/22 to 6/30/23	YEAR 3 7/1/23 to 6/30/24
		Total cost per ton	Total cost per ton	Total cost per ton
Monday thru Friday		\$ 19.00 per ton	\$ 20.00 per ton	\$ 21.00 per ton
Saturday		\$ 19.00 per ton	\$ 20.00 per ton	\$ 21.00 per ton
Holidays		\$ 30.00 per ton	\$ 32.00 per ton	\$ 33.00 per ton
<b>TOTAL COST</b> 13,000 Tons per fiscal year		\$ 247,000.00	\$ 260,000.00	\$ 273,000.00

**A SPECIAL NOTE FROM THE PURCHASING DIVISION**

*Bid results posted are before evaluation team review and award recommendation.*



**Biosolids Transportation Contract  
YEAR 1 BID FORM**

July 2022 to June 30, 2023

<b>LANDFILL</b>	<b>Republic Citizens Grand Blanc</b>	<b>Brent Run Montrose</b>	<b>Venice Park Lennon</b>	<b>Waste Management Birch Run</b>
<b>LOCATION</b>	2361 W Grand Blanc RD Grand Blanc MI 48439	8335 Vienna RD Montrose MI 48457	9536 E Lennon RD Lennon MI 48449	4143 East Rathbun RD Birch Run, MI 48415
<b>DISTANCE, Miles Travel Time</b>	<b>10.2</b> 12 minutes	<b>15.0</b> 17 minutes	<b>13.8</b> 19 minutes	<b>21.3</b> 29 minutes
<b>Cost per ton, per mile General rate</b>	<b>Cost per ton Trailer</b>			
\$	\$475.00 per trailer load	\$	\$	\$

**Biosolids Transportation Contract  
YEAR 2 BID FORM**

July 2022 to June 30, 2023

<b>LANDFILL</b>	<b>Republic Citizens Grand Blanc</b>	<b>Brent Run Montrose</b>	<b>Venice Park Lennon</b>	<b>Waste Management Birch Run</b>
<b>LOCATION</b>	2361 W Grand Blanc RD Grand Blanc MI 48439	8335 Vienna RD Montrose MI 48457	9536 E Lennon RD Lennon MI 48449	4143 East Rathbun RD Birch Run, MI 48415
<b>DISTANCE, Miles Travel Time</b>	<b>10.2</b> 12 minutes	<b>15.0</b> 17 minutes	<b>13.8</b> 19 minutes	<b>21.3</b> 29 minutes
<b>Cost per ton, per mile General rate</b>	<b>Cost per ton Trailer</b>			
\$	\$490.00 per trailer load	\$	\$	\$

**A SPECIAL NOTE FROM THE PURCHASING DIVISION**

*Bid results posted are before evaluation team review and award recommendation.*



## Biosolids Transportation Contract YEAR 3 BID FORM

~~July 1, 2023 to June 30, 2024~~

LANDFILL	Republic Citizens Grand Blanc	Brent Run Montrose	Venice Park Lennon	Waste Management Birch Run
LOCATION	2361 W Grand Blanc RD Grand Blanc MI 48439	8335 Vienna RD Montrose MI 48457	9536 E Lennon RD Lennon MI 48449	4143 East Rathbun RD Birch Run, MI 48415
DISTANCE, Miles Travel Time	<b>10.2</b> 12 minutes	<b>15.0</b> 17 minutes	<b>13.8</b> 19 minutes	<b>21.3</b> 29 minutes
Cost per ton, per mile General rate	<b>Cost per ton Trailer</b>			
\$	\$500.00 per trailer load	\$	\$	\$

**A SPECIAL NOTE FROM THE PURCHASING DIVISION**

*Bid results posted are before evaluation team review and award recommendation.*



## Biosolids (Landfill) Disposal Contract

### BID FORM

**Bidder #3: Waste Management of Michigan, Inc.**  
**4143 East Rathbun Rd., Birch Run, MI 48415**

Landfill (Sludge Disposal) Hours of Operation		YEAR 1 7/1/21 to 6/30/22	YEAR 2 7/1/22 to 6/30/23	YEAR 3 7/1/23 to 6/30/24
		Total cost per ton	Total cost per ton	Total cost per ton
Monday thru Friday	\$ 38.50	\$ 40.40	\$ 42.43	
Saturday	Closed	Closed	Closed	
Holidays	Closed	Closed	Closed	
<b>TOTAL COST 13,000 Tons per fiscal year</b>		<b>\$ 500,000.00</b>	<b>\$ 525,200.00</b>	<b>\$ 551,590.00</b>

**A SPECIAL NOTE FROM THE PURCHASING DIVISION**

*Bid results posted are before evaluation team review and award recommendation.*



**Biosolids Transportation Contract  
YEAR 1 BID FORM**

**July 1, 2022 to June 30, 2023**

<b>LANDFILL</b>	<b>Republic Citizens Grand Blanc</b>	<b>Brent Run Montrose</b>	<b>Venice Park Lennon</b>	<b>Waste Management Birch Run</b>
<b>LOCATION</b>	2361 W Grand Blanc RD Grand Blanc MI 48439	8335 Vienna RD Montrose MI 48457	9536 E Lennon RD Lennon MI 48449	4143 East Rathbun RD Birch Run, MI 48415
<b>DISTANCE, Miles Travel Time</b>	<b>10.2</b> 12 minutes	<b>15.0</b> 17 minutes	<b>13.8</b> 19 minutes	<b>21.3</b> 29 minutes
<b>Cost per ton, per mile General rate</b>	<b>Cost per ton</b>			
\$	\$ No Bid	\$ No Bid	\$ No Bid	\$ No Bid

**Biosolids Transportation Contract  
YEAR 2 BID FORM**

**July 1, 2022 to June 30, 2023**

<b>LANDFILL</b>	<b>Republic Citizens Grand Blanc</b>	<b>Brent Run Montrose</b>	<b>Venice Park Lennon</b>	<b>Waste Management Birch Run</b>
<b>LOCATION</b>	2361 W Grand Blanc RD Grand Blanc MI 48439	8335 Vienna RD Montrose MI 48457	9536 E Lennon RD Lennon MI 48449	4143 East Rathbun RD Birch Run, MI 48415
<b>DISTANCE, Miles Travel Time</b>	<b>10.2</b> 12 minutes	<b>15.0</b> 17 minutes	<b>13.8</b> 19 minutes	<b>21.3</b> 29 minutes
<b>Cost per ton, per mile General rate</b>	<b>Cost per ton</b>			
\$	\$ No Bid	\$ No Bid	\$ No Bid	\$ No Bid

**A SPECIAL NOTE FROM THE PURCHASING DIVISION**

*Bid results posted are before evaluation team review and award recommendation.*



## Biosolids Transportation Contract YEAR 3 BID FORM

July 1, 2023 to June 30, 2024

LANDFILL	Republic Citizens Grand Blanc	Brent Run Montrose	Venice Park Lennon	Waste Management Birch Run
<b>LOCATION</b>	2361 W Grand Blanc RD Grand Blanc MI 48439	8335 Vienna RD Montrose MI 48457	9536 E Lennon RD Lennon MI 48449	4143 East Rathbun RD Birch Run, MI 48415
<b>DISTANCE, Miles Travel Time</b>	<b>10.2</b> 12 minutes	<b>15.0</b> 17 minutes	<b>13.8</b> 19 minutes	<b>21.3</b> 29 minutes
<b>Cost per ton, per mile General rate</b>	<b>Cost per ton</b>			
\$	\$ No Bid	\$ No Bid	\$ No Bid	\$ No Bid

**A SPECIAL NOTE FROM THE PURCHASING DIVISION**

*Bid results posted are before evaluation team review and award recommendation.*

**CITY OF FLINT PROPOSAL NO. 21000605**

**Sewage Sludge Cake Disposal and Transport Services**

**THE FOLLOWING PAGES MUST BE COMPLETED AND INCLUDED WITH SUBMITTAL  
IN THE FOLLOWING ORDER.**

**Purchasing Checklist:**

- Cover Sheet
- Exhibit A – Bid Form Submittal
- Exhibit B – List of References
- Exhibit C – Certificate of Insurance
- Exhibit D - Non-Bidder's Response
- City of Flint, Michigan Affidavit



**BID SUBMITTAL FORM**

**EXHIBIT A**

**Biosolids (Landfill) Disposal Contract**

**BID FORM**

<b>BIDDER Name and Address</b>		DHT Transport 2695 W. Vassar Rd Reese, MI 48757		
<b>Landfill (Sludge Disposal) Hours of Operation</b>		<b>YEAR 1</b> 7/1/21 to 6/30/22	<b>YEAR 2</b> 7/1/22 to 6/30/23	<b>YEAR 3</b> 7/1/23 to 6/30/24
		<b>Total cost per ton</b>	<b>Total cost per ton</b>	<b>Total cost per ton</b>
Monday thru Friday		\$ No Bid	\$ No Bid	\$ No Bid
Saturday		\$ No Bid	\$ No Bid	\$ No Bid
Holidays		\$ No Bid	\$ No Bid	\$ No Bid
<b>TOTAL COST 13,000 Tons per fiscal year</b>		\$ No Bid	\$ No Bid	\$ No Bid

**Biosolids Transportation Contract  
YEAR 1 BID FORM**

July 1, 2021 to June 30, 2022

<b>BIDDER Name and Address</b>	DHT Transport 2695 W. Vassar Rd Reese, MI 48757			
<b>LANDFILL</b>	<b>Republic Citizens Grand Blanc</b>	<b>Brent Run Montrose</b>	<b>Venice Park Lennon</b>	<b>Waste Management Birch Run</b>
<b>LOCATION</b>	2361 W Grand Blanc RD Grand Blanc MI 48439	8335 Vienna RD Montrose MI 48457	9536 E Lennon RD Lennon MI 48449	4143 East Rathbun RD Birch Run MI 48415
<b>DISTANCE, Miles Travel Time</b>	<b>10.2</b> 12 minutes	<b>15.0</b> 17 minutes	<b>13.8</b> 19 minutes	<b>21.3</b> 29 minutes
<b>Cost per ton, per mile General rate</b>	<b>Cost per ton Trailer</b>			
§ N/A	§ 455.00	§ 455.00	§ 455.00	§ 500.00

**Biosolids Transportation Contract  
YEAR 2 BID FORM**

**July 1, 2022 to June 30, 2023**

<p align="center"><b>BIDDER Name and Address</b></p>	<p>DHT Transport 2695 W. Vassar Rd Reese, MI 48757</p>			
<p align="center"><b>LANDFILL</b></p>	<p align="center"><b>Republic Citizens Grand Blanc</b></p>	<p align="center"><b>Brent Run Montrose</b></p>	<p align="center"><b>Venice Park Lennon</b></p>	<p align="center"><b>Waste Management Birch Run</b></p>
<p align="center"><b>LOCATION</b></p>	<p>2361 W Grand Blanc RD Grand Blanc MI 48439</p>	<p>8335 Vienna RD Montrose MI 48457</p>	<p>9536 E Lennon RD Lennon MI 48449</p>	<p>4143 East Rathbun RD Birch Run MI 48415</p>
<p><b>DISTANCE, Miles</b> Travel Time</p>	<p align="center"><b>10.2</b> 12 minutes</p>	<p align="center"><b>15.0</b> 17 minutes</p>	<p align="center"><b>13.8</b> 19 minutes</p>	<p align="center"><b>21.3</b> 29 minutes</p>
<p><b>Cost per ton, per mile</b> General rate</p>	<p align="center"><b>Cost per ton Trailer</b></p>			
<p>\$ N/A</p>	<p>\$ 466.38</p>	<p>\$ 466.38</p>	<p>\$ 466.38</p>	<p>\$ 512.50</p>

## Biosolids Transportation Contract YEAR 3 BID FORM

July 1, 2023 to June 30, 2024

<b>BIDDER Name and Address</b>	DHT Transport 2695 W. Vassar Rd. Reese, MI 48757			
<b>LANDFILL</b>	<b>Republic Citizens Grand Blanc</b>	<b>Brent Run Montrose</b>	<b>Venice Park Lennon</b>	<b>Waste Management Birch Run</b>
<b>LOCATION</b>	2361 W Grand Blanc RD Grand Blanc MI 48439	8335 Vienna RD Montrose MI 48457	9536 E Lennon RD Lennon MI 48449	4143 East Rathbun RD Birch Run, MI 48415
<b>DISTANCE, Miles Travel Time</b>	<b>10.2</b> 12 minutes	<b>15.0</b> 17 minutes	<b>13.8</b> 19 minutes	<b>21.3</b> 29 minutes
<b>Cost per ton, per mile General rate</b>	<b>Cost per ton Trailer</b>			
\$ N/A	\$ 478.04	\$ 478.04	\$ 478.04	\$ 525.31

1. Failure to use this bid form shall result in bid disqualification.
2. Failure to bid on all items shall result in an "incomplete bid" determination.
3. List value-added considerations on a separate sheet of paper.

Terms: Net30 Fed. ID#: 47-4311495

Firm Name: DHT Transport

Address: 2695 W. Vassar Rd.

City/State/Zip: Reese, MI 48757

Phone: 989-759-2010 Fax: 989-759-2019 Email: jzimmerman@dht-inc.com

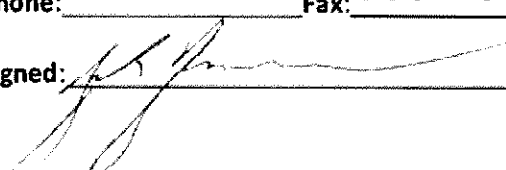
Signed:  Date: 3/23/21



3/24/2021

City of Flint

Finance Department-Division of Purchases and Supplies

1101 S Saginaw St M203

Flint, MI 48502

RFP Title: Sewage Sludge Cake Disposal and Transport Services

RFP Num: 21000605

Deadline: 3/24/2021

Proposer: DHT Transport

To Whom it may Concern:

Scope of Work Changes have been made to the original proposal set forth by the City of Flint. DHT Transport requests the bid scope be changed from "per ton" to "per trailer". In this case "per trailer" refers to each unit being counted separately for purposes of billing. DHT Transport will continue to provide equipment capable of hauling the proposed 25 ton. Due to production at the plant, tonnage per trailer may vary. DHT Transport is attempting to level our cost and simplify billing. DHT Transport returns the landfill manifest each day to the plant for verification purposes.

**EXHIBIT B**

*Sewage Sludge Cake Disposal and Transport Services*

**LIST OF REFERENCES: (3) SIMILAR SCOPE OF WORK FROM THE LAST 5 YEARS**

Providing the following contact information enables the City of Flint to contact those accounts as references.

**Reference #1:**

Company/Municipality: City of Flint Water Pollution Control  
Contact Person: Don Lewis Title: Operations Supervisor  
Address: 4652 Beecher Rd  
City: Flint State: MI Zip: 48532  
Telephone: 810-282-5176 Fax: 810-732-7044  
Email: dlewis@cityofflint.com  
Type of Project: Sludge cake haul to landfill locations

Project Timeline (Dates): on going Budget: N/A

**Reference #2:**

Company/Municipality: Biotech  
Contact Person: Don Popma Title: General Manager  
Address: 1651 Beulah Hwy  
City: Beulah State: MI Zip: 49617  
Telephone: 231-882-7219 Fax: \_\_\_\_\_  
Email: dpopma@biotechag.com  
Type of Project: treated solid waste hauling to agricultural fields for disposal

Project Timeline (Dates): on going Budget: N/A

**EXHIBIT B**

*Sewage Sludge Cake Disposal and Transport Services*

**LIST OF REFERENCES: (3) SIMILAR SCOPE OF WORK FROM THE LAST 5 YEARS (continues)**

**Reference #3:**

Company/Municipality: Waste Management

Contact Person: Kevin Beste Title: Account Manager

Address: 48797 Alpha Dr, STE 150

City: Wixom State: MI Zip: 48393

Telephone: 248-640-8338 Fax: \_\_\_\_\_

Email: kbeste@wm.com

Type of Project: Sludge hauling and diverse environmental hauling projects

Project Timeline (Dates): on-going Budget: N/A

Client#: 60051

HAUBR

ACORD

CERTIFICATE OF LIABILITY INSURANCE

DATE (MM/DD/YYYY)  
2/22/2021

THIS CERTIFICATE IS ISSUED AS A MATTER OF INFORMATION ONLY AND CONFERS NO RIGHTS UPON THE CERTIFICATE HOLDER. THIS CERTIFICATE DOES NOT AFFIRMATIVELY OR NEGATIVELY AMEND, EXTEND OR ALTER THE COVERAGE AFFORDED BY THE POLICIES BELOW. THIS CERTIFICATE OF INSURANCE DOES NOT CONSTITUTE A CONTRACT BETWEEN THE ISSUING INSURER(S), AUTHORIZED REPRESENTATIVE OR PRODUCER, AND THE CERTIFICATE HOLDER.

IMPORTANT: If the certificate holder is an ADDITIONAL INSURED, the policy(ies) must be endorsed. If SUBROGATION IS WAIVED, subject to the terms and conditions of the policy, certain policies may require an endorsement. A statement on this certificate does not confer rights to the certificate holder in lieu of such endorsement(s).

<b>PRODUCER</b> Saginaw Bay Underwriters 1258 S. Washington P.O. Box 1928 Saginaw, MI 48605	<b>CONTACT NAME:</b> PHONE (A/C, No, Ext): 989 752-8600 FAX (A/C, No):	
	<b>E-MAIL ADDRESS:</b> <b>PRODUCER CUSTOMER ID #:</b>	
<b>INSURED</b> Hausbeck Brothers, Inc. DBA D.H.T. Logistics P.O. Box 375 Reese, MI 48757-0375	<b>INSURER(S) AFFORDING COVERAGE</b>	
	<b>INSURER A:</b> Auto Owners Insurance Co.	<b>NAIC #</b> 18988
	<b>INSURER B:</b> Arch Specialty Insurance Co.	<b>NAIC #</b> 21199
	<b>INSURER C:</b> Federal Insurance Co.	<b>NAIC #</b> 002084
	<b>INSURER D:</b> Hartford Fire Insurance Co.	<b>NAIC #</b> 19682
	<b>INSURER E:</b> <b>INSURER F:</b>	

COVERAGES CERTIFICATE NUMBER: REVISION NUMBER:

THIS IS TO CERTIFY THAT THE POLICIES OF INSURANCE LISTED BELOW HAVE BEEN ISSUED TO THE INSURED NAMED ABOVE FOR THE POLICY PERIOD INDICATED. NOTWITHSTANDING ANY REQUIREMENT, TERM OR CONDITION OF ANY CONTRACT OR OTHER DOCUMENT WITH RESPECT TO WHICH THIS CERTIFICATE MAY BE ISSUED OR MAY PERTAIN THE INSURANCE AFFORDED BY THE POLICIES DESCRIBED HEREIN IS SUBJECT TO ALL THE TERMS, EXCLUSIONS AND CONDITIONS OF SUCH POLICIES. LIMITS SHOWN MAY HAVE BEEN REDUCED BY PAID CLAIMS.

INSR STR	TYPE OF INSURANCE	ADDL BUENR INSR WVD	POLICY NUMBER	POLICY EFF (MM/DD/YYYY)	POLICY EXP (MM/DD/YYYY)	LIMITS
A	GENERAL LIABILITY <input checked="" type="checkbox"/> COMMERCIAL GENERAL LIABILITY CLAIMS-MADE <input checked="" type="checkbox"/> OCCUR GEN'L AGGREGATE LIMIT APPLIES PER <input type="checkbox"/> POLICY <input type="checkbox"/> PROJECT <input type="checkbox"/> LOC		1405217921	03/01/2021	03/01/2022	EACH OCCURRENCE \$1,000,000 DAMAGE TO RENTED PREMISES (Ea occurrence) \$50,000 MED EXP (Any one person) \$5,000 PERSONAL & ADV INJURY \$1,000,000 GENERAL AGGREGATE \$2,000,000 PRODUCTS - COMPIOP AGG \$2,000,000 \$
D	AUTOMOBILE LIABILITY <input checked="" type="checkbox"/> ANY AUTO ALL OWNED AUTOS SCHEDULED AUTOS HIRED AUTOS NON-OWNED AUTOS <input checked="" type="checkbox"/> Drive Other Car		83UENOH7010	03/01/2021	03/01/2022	COMBINED SINGLE LIMIT (Ea accident) \$2,000,000 BODILY INJURY (Per person) \$ BODILY INJURY (Per accident) \$ PROPERTY DAMAGE (Per accident) \$ \$ \$
A	<input checked="" type="checkbox"/> UMBRELLA LIAB <input checked="" type="checkbox"/> OCCUR EXCESS LIAB <input type="checkbox"/> CLAIMS-MADE DEDUCTIBLE <input checked="" type="checkbox"/> RETENTION \$ 10000		4300942502	03/01/2021	03/01/2022	EACH OCCURRENCE \$8,000,000 AGGREGATE \$6,000,000 \$ \$
D	WORKERS COMPENSATION AND EMPLOYERS' LIABILITY ANY PROPRIETOR/PARTNER/EXECUTIVE OFFICER/MEMBER EXCLUDED? (Mandatory in MI) If yes, describe under DESCRIPTION OF OPERATIONS below	Y/N <input checked="" type="checkbox"/> N N/A	83WEOH7009	03/01/2021	03/01/2022	<input checked="" type="checkbox"/> WC STATUTORY LIMITS <input type="checkbox"/> OTHER E.L. EACH ACCIDENT \$1,000,000 E.L. DISEASE - EA EMPLOYEE \$1,000,000 E.L. DISEASE - POLICY LIMIT \$1,000,000
C	Motor Truck Cargo Reefer Coverage		06659684	03/01/2021	03/01/2022	\$400,000 Limit \$15,000 Deductible

DESCRIPTION OF OPERATIONS / LOCATIONS / VEHICLES (Attach ACORD 101, Additional Remarks Schedule, if more space is required)

Excess Umbrella (Auto Owners) #4300942502 goes over the General Liability.  
 -Letter B: Excess Umbrella (Arch Specialty Insurance Co.) #UXP1027939-01 - Limits of \$3,000,000  
 (See Attached Descriptions)

<b>CERTIFICATE HOLDER</b> City of Flint 1101 S Saginaw St Flint, MI 48301	<b>CANCELLATION</b> SHOULD ANY OF THE ABOVE DESCRIBED POLICIES BE CANCELLED BEFORE THE EXPIRATION DATE THEREOF, NOTICE WILL BE DELIVERED IN ACCORDANCE WITH THE POLICY PROVISIONS. AUTHORIZED REPRESENTATIVE 
--	--



## DESCRIPTIONS (Continued from Page 1)

each occurrence and \$3,000,000 aggregate - Policy Term 03/01/2021-03/01/2022 goes over the Automobile Policy, Workers Compensation and the Umbrella Policy (Auto Owners)  
-Pollution Liability broad coverage for covered autos is included in the Automobile Policy form #CA9948.  
-Form MCS-90 is included. Waiver of Subrogation does apply.

**\*\* Supplemental Name \*\***

Hausbeck Brothers, Inc. DBA D.H.T. Logistics  
David Hausbeck  
D.H.T. Specialized, LLC  
D.H.T. Transport, LLC  
D.H.T. Express, LLC  
D.H.T. Agricultural Transport, LLC

City of Flint and including all elected and appointed officials, all employees and volunteers, all boards, commissions and/or authorities and their board members, employees and volunteers are included as additional insureds with respects to the general liability on a primary and non contributory basis and the auto liability. 30 Day notice of cancellation (10 Day Notice for nonpayment of premium) applies. (6/17)

**EXHIBIT D**

*Sewage Sludge Cake Disposal and Transport Services*  
**NON-BIDDER'S RESPONSE**

**VENDORS NAME:** \_\_\_\_\_

For the purpose of facilitating your firm's response to our invitation to bid, the City of Flint is interested in ascertaining reasons for prospective bidder's failure to respond to "Invitations to Bid". If your firm is not responding to this bid, please indicate the reason(s) by checking any appropriate item(s) below and return this form to the above address.

We are *not* responding to this "Invitation to Bid" for the following reason(s):

\_\_\_\_\_ Items or materials requested not manufactured by us or not available to our company.

\_\_\_\_\_ Our items and/or materials do not meet specifications.

\_\_\_\_\_ Specifications not clearly understood or applicable (too vague, too rigid, etc.).

\_\_\_\_\_ Quantities too Small.

\_\_\_\_\_ Insufficient time allowed for preparation of bid.

\_\_\_\_\_ Incorrect address used. Our correct mailing address is: \_\_\_\_\_

\_\_\_\_\_ Our branch / division handles this type of bid. We have forwarded this bid on to them but for the future the correct name and mailing address is: \_\_\_\_\_

\_\_\_\_\_ **OTHER:** \_\_\_\_\_

**Thank you for your participation in this bid.**

CITY OF FLINT, MICHIGAN AFFIDAVIT

AFFIDAVIT FOR INDIVIDUAL

STATE OF Michigan

S.S.

COUNTY OF Saginaw

[Signature] being duly sworn, deposes and says that they are the person making the above bid; and that said bid is genuine and not sham or collusive, and is not made in the interest of or on behalf of any person not therein named, and that they have not directly or indirectly induced or solicited any bidder to put in a sham bid; that they have not directly or indirectly induced or solicited any other person or corporation to refrain from bidding, and that they have not in any manner sought by collusion to secure themselves any advantage over other bidders.

Subscribed and sworn to before me at D.H.T. Transport, in said County and State,

this 24 day of March, A.D. 2021,

Christophe Ryz

\*Notary Public, Tuscola County, Michigan

My Commission expires April 09, 2027

NOTE: If executed outside of the State of Michigan, certificate by the Clerk of the Court of Record, authenticating the Notary's Signature and authority should be attached.

FOR CORPORATION

STATE OF Michigan

S.S.

COUNTY OF Saginaw

Josh Zimmerman being duly sworn, deposes and says that she/he/they  
is General Manager of DHT Transport

(Official Title)

(Name of Corporation)

a corporation duly organized and doing business under the laws of the State of Michigan  
the corporation making the within and foregoing bid; that they executed said bid in behalf of said corporation by  
authority of its Board of Directors; that said bid is genuine and not sham or collusive and is not made in the  
interests of or on behalf of any person not herein named, and that they have not and said bidder has not directly  
or indirectly induced or solicited any other person or corporation to refrain from bidding; that they have not and  
said bidder has not in any manner sought by collusion to secure to themselves or to said corporation an advantage  
over other bidders.

Subscribed and sworn to before me at DHT Transport, in said County and State,  
this 24 day of March, A.D. 2021

Christopher R. [Signature]  
\*Notary Public, Tuscola County, Michigan

My Commission expires April 09, 2027

NOTE: If executed outside of the State of Michigan, certificate by the Clerk of the Court of Record, authenticating the Notary's Signature and authority should be attached.

**CITY OF FLINT PROPOSAL NO. 21000605**

**Sewage Sludge Cake Disposal and Transport Services**

**THE FOLLOWING PAGES MUST BE COMPLETED AND INCLUDED WITH SUBMITTAL  
IN THE FOLLOWING ORDER.**

**Purchasing Checklist:**

- Cover Sheet
- Exhibit A – Bid Form Submittal
- Exhibit B – List of References
- Exhibit C – Certificate of Insurance
- Exhibit D - Non-Bidder's Response
- City of Flint, Michigan Affidavit

**BID SUBMITTAL FORM**

**EXHIBIT A**

**Biosolids (Landfill) Disposal Contract**

**BID FORM**

<b>BIDDER Name and Address</b>		Republic Services of Flint 4101 Holiday Drive Flint, MI 48507		
<b>Landfill (Sludge Disposal) Hours of Operation</b>		<b>YEAR 1</b> 7/1/21 to 6/30/22	<b>YEAR 2</b> 7/1/22 to 6/30/23	<b>YEAR 3</b> 7/1/23 to 6/30/24
		<b>Total cost per ton</b>	<b>Total cost per ton</b>	<b>Total cost per ton</b>
Monday thru Friday		\$19.00 per ton \$	\$20.00 per ton \$	\$21.00 per ton \$
Saturday		\$19.00 per ton \$	\$20.00 per ton \$	\$21.00 per ton \$
Holidays		\$30.00 per ton \$	\$32.00 per ton \$	\$33.00 per ton \$
<b>TOTAL COST 13,000 Tons per fiscal year</b>		\$247,000.00 \$	\$260,000.00 \$	\$273,000.00 \$

# Biosolids Transportation Contract

YEAR 1 BID FORM

July 1, 2021 to June 30, 2022

<b>BIDDER Name and Address</b>				
<b>LANDFILL</b>	<b>Republic Citizens Grand Blanc</b>	<b>Brent Run Montrose</b>	<b>Venice Park Lennon</b>	<b>Waste Management Birch Run</b>
<b>LOCATION</b>	2361 W Grand Blanc RD Grand Blanc MI 48439	8335 Vienna RD Montrose MI 48457	9536 E Lennon RD Lennon MI 48449	4143 East Rathbun RD Birch Run, MI 48415
<b>DISTANCE, Miles Travel Time</b>	<b>10.2</b> 12 minutes	<b>15.0</b> 17 minutes	<b>13.8</b> 19 minutes	<b>21.3</b> 29 minutes
<b>Cost per ton, per mile General rate</b>	<b>Cost per <del>ton</del> Trailer</b>			
\$	\$475.00 per trailer load \$	\$	\$	\$

## Biosolids Transportation Contract YEAR 2 BID FORM

**July 1, 2022 to June 30, 2023**

<b>BIDDER Name and Address</b>				
<b>LANDFILL</b>	<b>Republic Citizens Grand Blanc</b>	<b>Brent Run Montrose</b>	<b>Venice Park Lennon</b>	<b>Waste Management Birch Run</b>
<b>LOCATION</b>	2361 W Grand Blanc RD Grand Blanc MI 48439	8335 Vienna RD Montrose MI 48457	9536 E Lennon RD Lennon MI 48449	4143 East Rathbun RD Birch Run, MI 48415
<b>DISTANCE, Miles Travel Time</b>	<b>10.2</b> 12 minutes	<b>15.0</b> 17 minutes	<b>13.8</b> 19 minutes	<b>21.3</b> 29 minutes
<b>Cost per ton, per mile General rate</b>	<b>Cost per <del>ton</del> Trailer</b>			
\$	\$490.00 per trailer load \$	\$	\$	\$



## Biosolids Transportation Contract YEAR 3 BID FORM

July 1, 2023 to June 30, 2024

<b>BIDDER Name and Address</b>				
<b>LANDFILL</b>	<b>Republic Citizens Grand Blanc</b>	<b>Brent Run Montrose</b>	<b>Venice Park Lennon</b>	<b>Waste Management Birch Run</b>
<b>LOCATION</b>	2361 W Grand Blanc RD Grand Blanc MI 48439	8335 Vienna RD Montrose MI 48457	9536 E Lennon RD Lennon MI 48449	4143 East Rathbun RD Birch Run, MI 48415
<b>DISTANCE, Miles Travel Time</b>	<b>10.2</b> 12 minutes	<b>15.0</b> 17 minutes	<b>13.8</b> 19 minutes	<b>21.3</b> 29 minutes
<b>Cost per ton, per mile General rate</b>	<b>Cost per <del>ton</del><sup>XXXX</sup> Trailer</b>			
\$	\$500.00 per trailer load	\$	\$	\$

1. Failure to use this bid form shall result in bid disqualification.
2. Failure to bid on all items shall result in an "incomplete bid" determination.
3. List value-added considerations on a separate sheet of paper.

Terms: Net 30 days

Fed. ID#: 38-3293469

Firm Name: Republic Services

Address: 4101 Holiday drive

City/State/Zip Flint, MI 48507

Phone: 810/768/2222 Fax: \_\_\_\_\_ Email: Tjohnston@republicservices.com

Signed:  Date: 03/24/2021

**EXHIBIT B**

*Sewage Sludge Cake Disposal and Transport Services*

**LIST OF REFERENCES: (3) SIMILAR SCOPE OF WORK FROM THE LAST 5 YEARS**

Providing the following contact information enables the City of Flint to contact those accounts as references.

**Reference #1:**

Company/Municipality: City of Bay City

Contact Person: Phil Smith Title: Director of Operations

Address: 2905 N Water Street

City: Bay City State: MI Zip: 48708

Telephone: (989) 893-5121 Fax: \_\_\_\_\_

Email: Psmith@baycitymi.org

Type of Project: Sludge filter cake hauling and disposal

Project Timeline (Dates): 07/01/18 through current Budget: \$150,000 annually

**Reference #2:**

Company/Municipality: Genoa Osceola Sewer and Water authority

Contact Person: Jim Aulette Title: Director

Address: 2911 Dorr Road

City: Brighton, State: MI Zip: 48116

Telephone: (517) 642-9653 Fax: \_\_\_\_\_

Email: jima@mhog.org

Type of Project: Sludge filter cake hauling and disposal

Project Timeline (Dates): 4-20-15 through present Budget: \$200,000 annually

**EXHIBIT B**

*Sewage Sludge Cake Disposal and Transport Services*

**LIST OF REFERENCES: (3) SIMILAR SCOPE OF WORK FROM THE LAST 5 YEARS (continues)**

**Reference #3:**

Company/Municipality: North Kent Sewer Authority

Contact Person: Scott Schoolcraft Title: Director

Address: 4775 Coit Ave N.E.

City: Grand Rapids State: MI Zip: 49525

Telephone: (616) 363-0702 Fax: \_\_\_\_\_

Email: jschoolcraft@nksa.us

Type of Project: Sludge filter cake hauling and disposal

Project Timeline (Dates): 1-01-2012 through present Budget: \$500,000 annually

## **EXHIBIT C**

### *Sewage Sludge Cake Disposal and Transport Services*

#### **CERTIFICATE OF INSURANCE**

##### **INSURANCE REQUIREMENTS**

The Contractor shall notify all insurance agents and companies retained by the Contractor that these insurance requirements shall be included in any Agreement between the Contractor and the City of Flint.

The Contractor shall purchase and maintain, at its sole expense and as long as it is providing services to the City, the following insurance coverage:

Commercial General Liability - Occurrence form, including coverage for bodily injury, personal injury, property damage (broad form), premises/operations, blanket contractual, and products/completed operations. Coverage shall be endorsed to include the City as an additional insured for work performed by the Contractor in accordance with the Agreement.

##### Minimum Limits:

- \$1,000,000 per occurrence/\$2,000,000 general aggregate
- \$2,000,000 aggregate for products and completed operations
- \$1,000,000 personal and advertising injury

Automobile - Michigan "no-fault" coverage, and residual automobile liability, comprehensive form, covering owned, hired, and non-owned automobiles. Coverage shall be endorsed to include the City as an additional insured for work performed by the Contractor in accordance with the Agreement.

##### Minimum Limits:

- No-fault coverages - statutory
- \$500,000 per person/\$1,000,000 per accident - bodily injury
- \$500,000 per occurrence - property damage
- A combined single limit of \$1,000,000 per occurrence

Workers' Compensation and Employer's Liability- Statutory coverage or proof acceptable to the City of approval as a self-insurer by the State of Michigan.

**EXHIBIT C**

*Sewage Sludge Cake Disposal and Transport Services*  
**CERTIFICATE OF INSURANCE (continues)**

Minimum Limits:

- Workers' Compensation - statutory
- Employer's Liability - \$100,000 each accident/\$100,000 disease - each employee
- \$500,000 disease - policy limit

Professional Liability – Covering acts, errors or omissions of a professional nature committed or alleged to have been committed by the Contractor or any of its subcontractors. Coverage shall be effective upon the date of the Agreement and shall remain effective for a period of three (3) years after the date of final payment thereunder. Such coverage shall be endorsed to include any subcontractors hired by the City.

Minimum Limits:

- \$1,000,000 per occurrence, \$1,000,000 annual aggregate

Insurance coverage shall cover all claims against the City of Flint, its officials and employees, arising out of the work performed by the Contractor or any subcontractors under the Agreement. Should any work be subcontracted, it shall be the responsibility of the Contractor to maintain Independent Contractor's Protective Liability Insurance with limits equal to those specified above for Commercial General Liability Insurance. In addition, the Contractor shall provide proof of Workers' Compensation Insurance for all subcontractors in compliance with the required statutory limits of the State of Michigan.

Said policies of insurance shall be with companies licensed to do business in the State of Michigan and in a form satisfactory to the City. All insurance companies must maintain a rating of B+, VIII or better from AM. Best Company. Certificates of insurance with a thirty-(30) day cancellation clause shall be filed with and approved by the City at least five (5) days in advance of commencing work under the Agreement. Cancellation, material restriction, non-renewal or lapse of any of the required policies shall be grounds for immediate termination of the Agreement by the City.

The City reserves the right to request a complete certified copy of the policies for the above coverage's.

Any reduction or exhaustion in the limits of required insurance coverage shall not be deemed to limit the indemnification afforded in accordance with the Agreement or any amendments thereto.

Depending on the subject matter of the transaction, the City may require other insurance coverage in addition to the coverage's contained herein.

**THE BID NUMBER IS TO APPEAR ON ALL INSURANCE CERTIFICATES**





# ADDITIONAL REMARKS SCHEDULE

AGENCY		NAMED INSURED	
POLICY NUMBER See First Page		REPUBLIC SERVICES, INC. 18500 N. ALLIED WAY PHOENIX, AZ 85054	
CARRIER See First Page	NAIC CODE	EFFECTIVE DATE:	
ADDITIONAL REMARKS		CERTIFICATE NUMBER: 1755559	

THIS ADDITIONAL REMARKS FORM IS A SCHEDULE TO ACORD FORM.  
 FORM NUMBER: 25 FORM TITLE: CERTIFICATE OF LIABILITY INSURANCE

The following provisions apply when required by written contract. As used below, the term certificate holder also includes any person or organization that the insured has become obligated to include as a result of an executed contract or agreement.

**GENERAL LIABILITY:**

Certificate holder is Additional Insured including on-going and completed operations when required by written contract.  
 Coverage is primary and non-contributory when required by written contract.  
 Waiver of Subrogation in favor of the certificate holder is included when required by written contract.

**AUTO LIABILITY:**

Certificate holder is Additional Insured when required by written contract.  
 Coverage is primary and non-contributory when required by written contract.  
 Waiver of Subrogation in favor of the certificate holder is included when required by written contract.

**WORKERS COMPENSATION AND EMPLOYERS LIABILITY:**

Waiver of Subrogation in favor of the certificate holder is included when required by written contract where allowed by state law.

Stop gap coverage for ND, WA and WY is covered under policy no. WLR C67458424 and stop gap coverage for OH is covered under policy no. WCU C67458503, as noted on page 1 of this certificate.

**TEXAS EXCESS INDEMNITY AND EMPLOYERS LIABILITY:**

Insured is a registered non-subscriber to the Texas Workers Compensation Act. Insured has filed an approved Indemnity Plan with the Texas Department of Insurance which offers an alternative in benefits to employees rather than the traditional Workers Compensation Insurance in Texas. The excess policy (#TNS C66948560) shown on this certificate provides excess Indemnity and Employers Liability coverage for the approved Indemnity Plan.

Contractual Liability is included in the General Liability and Automobile Liability coverage forms. The General Liability and Automobile Liability policies do not contain endorsements excluding Contractual Liability.

Separation of Insured (Cross Liability) coverage is provided to the Additional Insured, when required by written contract, per the Conditions of the Commercial General Liability Coverage form and the Automobile Liability Coverage form.

Additional Insured includes: City of Flint, all elected and appointed officials, all employees and volunteers, all boards, commissioners, and/or authorities and their board members, employees and volunteers, when required by written contract.

**NOTICE TO OTHERS ENDORSEMENT - NOTICE BY INSURED'S REPRESENTATIVE**

Named Insured Republic Services, Inc.			Endorsement Number 61
Policy Symbol HDO	Policy Number G71450892	Policy Period 06/30/2020 TO 06/30/2021	Effective Date of Endorsement
Issued By (Name of Insurance Company) ACE American Insurance Company			

**THIS ENDORSEMENT CHANGES THE POLICY. PLEASE READ IT CAREFULLY.**

**THIS ENDORSEMENT MODIFIES INSURANCE PROVIDED UNDER THE FOLLOWING:**

**COMMERCIAL GENERAL LIABILITY COVERAGE FORM**

- A. If we cancel, non-renew, or materially change the Policy prior to its expiration date by notice to the first Named Insured for any reason other than nonpayment of premium, we will, as set out in this endorsement, send written notice of such cancellation, non-renewal or material change, to the first Named Insured and will allow its representative to send such notice to all persons or organizations that the first Named Insured has contractually agreed to provide such notice.
- B. The notice referenced in this endorsement as provided by your representative is intended only to be a courtesy notification. The failure to provide advance notification of cancellation, non renewal, or material change will impose no obligation or liability of any kind upon us, our agents or representatives, will not extend any Policy cancellation date and will not negate any cancellation, non-renewal or material change of the Policy.
- C. We will only be responsible for sending such notice to the first Named Insured who will notify its representative, and its representative will, in turn, send all applicable persons or organizations notice of cancellation, non-renewal, or material change at least 30 days prior to the applicable event date
- D. This endorsement does not apply in the event that the first Named Insured cancels the Policy.

All other terms and conditions of the Policy remain unchanged



**EXHIBIT D**

*Sewage Sludge Cake Disposal and Transport Services*  
**NON-BIDDER'S RESPONSE**

**VENDORS NAME:** \_\_\_\_\_

For the purpose of facilitating your firm's response to our invitation to bid, the City of Flint is interested in ascertaining reasons for prospective bidder's failure to respond to "Invitations to Bid". If your firm is not responding to this bid, please indicate the reason(s) by checking any appropriate item(s) below and return this form to the above address.

We are *not* responding to this "Invitation to Bid" for the following reason(s):

\_\_\_\_\_ Items or materials requested not manufactured by us or not available to our company.

\_\_\_\_\_ Our items and/or materials do not meet specifications.

\_\_\_\_\_ Specifications not clearly understood or applicable (too vague, too rigid, etc.).

\_\_\_\_\_ Quantities too Small.

\_\_\_\_\_ Insufficient time allowed for preparation of bid.

\_\_\_\_\_ Incorrect address used. Our correct mailing address is: \_\_\_\_\_

\_\_\_\_\_

\_\_\_\_\_ Our branch / division handles this type of bid. We have forwarded this bid on to them but for the future the correct name and mailing address is: \_\_\_\_\_

\_\_\_\_\_ **OTHER:** \_\_\_\_\_

\_\_\_\_\_

**Thank you for your participation in this bid.**

FOR CORPORATION

STATE OF Michigan

S.S.

COUNTY OF Genesee

Metrel Demps Metrel Demps being duly sworn, deposes and says that she/he/they  
is General Manager of Tri County Refuse DBA (Republic Services of Flint)

(Official Title)

(Name of Corporation)

a corporation duly organized and doing business under the laws of the State of Deleware  
the corporation making the within and foregoing bid; that they executed said bid in behalf of said corporation by  
authority of its Board of Directors; that said bid is genuine and not sham or collusive and is not made in the  
interests of or on behalf of any person not herein named, and that they have not and said bidder has not directly  
or indirectly induced or solicited any other person or corporation to refrain from bidding; that they have not and  
said bidder has not in any manner sought by collusion to secure to themselves or to said corporation an advantage  
over other bidders.

Subscribed and sworn to before me at Republic Services, in said County and State,  
this 23 day of MARCH, A.D. 2021

Lisa M Perry

\*Notary Public, Genesee County, Michigan

My Commission expires 9-12, 2023

NOTE: If executed outside of the State of Michigan, certificate by the Clerk of the Court of Record, authenticating the Notary's Signature and authority should be attached.

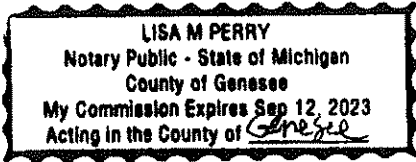





GRAND BLANC ROAD

- FACILITY PROPERTY = 313.7 AC.
- AREA SITED FOR USE = 236.5 AC.
- ▤ PERMITTED WASTE AREA = 109.0 AC.
- ▨ SOIL STOCKPILE/FUTURE EXPANSION

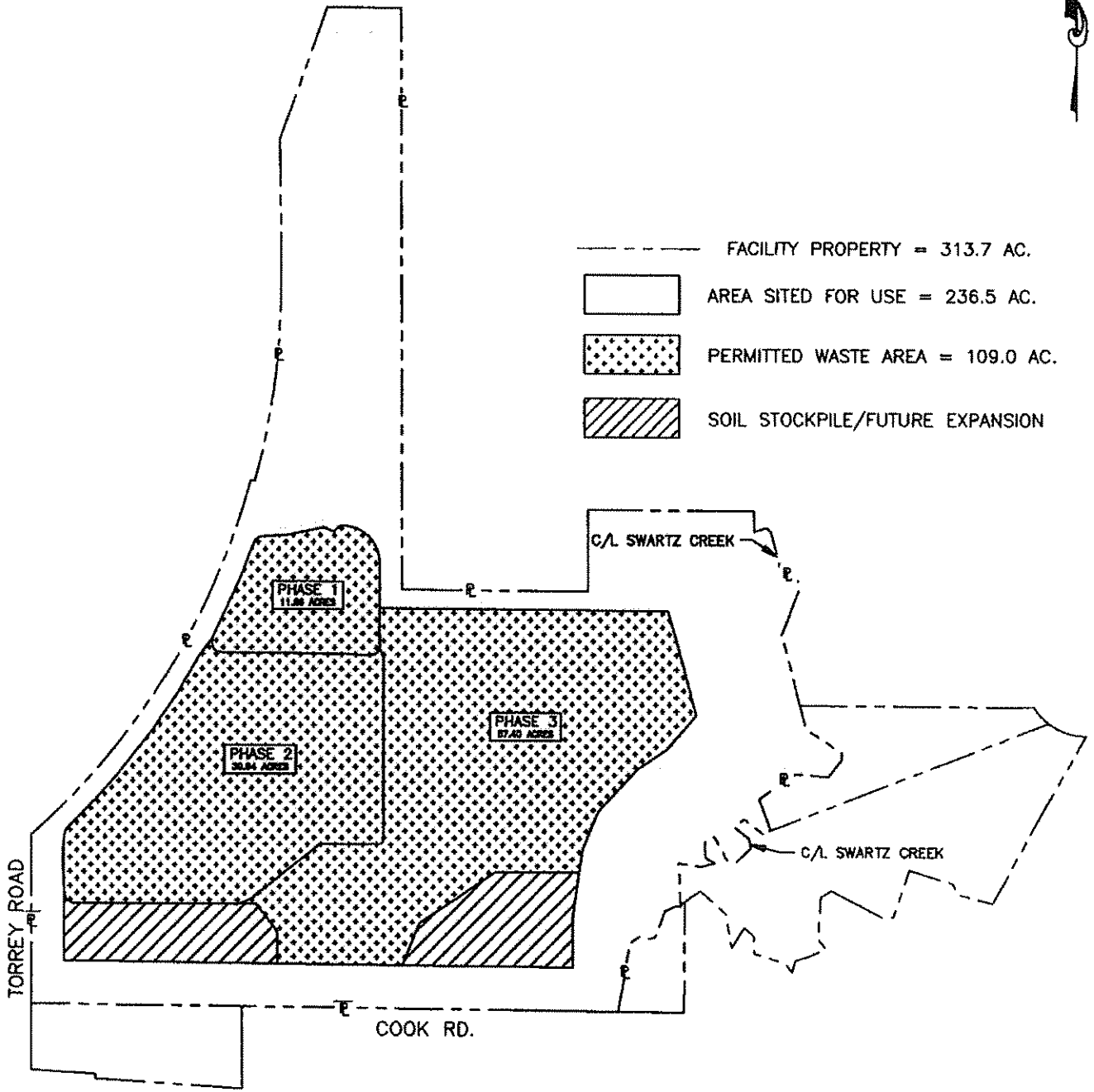

# MIDWESTERN CONSULTING



Civil, Environmental and  
 Transportation Engineers  
 Planners, Surveyors  
 Landscape Architects

3815 Plaza Drive  
 Ann Arbor, Michigan 48108  
 Phone: 734.995.0200  
 Fax 734.995.0599

## CITIZENS DISPOSAL, INC. SITE PLAN

DATE: 6/28/12      JOB NO.: **00022**

SCALE: 1" = 800'



SHEET 1 OF 1



GRETCHEN WHITMER  
GOVERNOR

STATE OF MICHIGAN  
DEPARTMENT OF  
ENVIRONMENT, GREAT LAKES, AND ENERGY  
LANSING DISTRICT OFFICE



LIESL EICHLER CLARK  
DIRECTOR

July 16, 2020

Mr. Derek Neal  
Citizens Disposal, Inc.  
2361 West Grand Blanc Road  
Grand Blanc, Michigan 48439

Dear Mr. Neal:

SUBJECT: In Compliance; Citizens Disposal, Inc.  
Waste Data System Number 470517

On June 26, 2020, Department of Environment, Great Lakes, and Energy, Materials Management Division (MMD), staff conducted an inspection of Citizens Disposal Landfill, located at 2361 West Grand Blanc Road, Grand Blanc, Genesee County, Michigan, to evaluate compliance with Part 115, Solid Waste Management, of the Natural Resources and Environmental Protection Act, 1994 PA 451, as amended; the administrative rules promulgated pursuant to Part 115; and Citizens Disposal's Solid Waste Disposal Area Operating License Number 9530 issued on August 21, 2018. A copy of the completed inspection form is enclosed.

Based upon information obtained and observations made during the inspection, MMD staff has determined that Citizens Disposal is in compliance with the requirements of Part 115 that were evaluated.

If you have any questions, please feel free to contact me at the telephone number below or by e-mail at [MaguireE@Michigan.gov](mailto:MaguireE@Michigan.gov).

Sincerely,

Evin P. Maguire  
Geologist  
Materials Management Division  
517-388-3525

Enclosure

**Michigan Department of Environmental Quality  
Waste Management and Radiological Protection Division  
Part 115 - Landfill Evaluation Report**

<b>Name of Facility</b> CITIZENS DISPOSAL INC		<b>Facility Number</b> 470517		<b>License # and Expiration Date</b> 9462      1/6/2021													
<b>Facility Address</b> 2361 W GRAND BLANC RD, GRAND BLANC, MI		<b>Facility Contact : Name - Phone Number</b> ROBERT THORNTON      810-655-4207															
<b>LEGEND: (C) = Compliance (V) = Violation (NE) = Not Evaluated (* ) = See Note (-) = Does not Apply</b>																	
<i>General Operations</i>			<i>Leachate / Stormwater Mangement</i>														
C	A.	Miscellaneous Operational Issues	C	J.	Surface Water Discharge												
C	B.	Blowing Debris, Dust, Odor & Vector Control	C	K.	Protection of Surface Waters												
C	C.	Gas Monitoring & Migration	C	L.	Leachate Control / Mangement												
No	D.	Are there any exceedances of the LEL?	C	M.	Leachate Volume / Head Records												
<i>Prohibited Waste Restrictions</i>			C	N.	Secondary Volume / ARF / RFR Records												
<table border="1" style="width: 100%; border-collapse: collapse;"> <tr> <td>C</td> <td>E.</td> <td>Hazardous Waste / Liquids / Yard Waste / Other Materials Prohibited for Disposal</td> </tr> <tr> <td>C</td> <td>F.</td> <td>Random / Suspicious Load Records</td> </tr> <tr> <td>C</td> <td>G.</td> <td>Load Inspection During Evaluation</td> </tr> <tr> <td>0</td> <td># of Loads Inspected</td> <td>0 yds. Volume of Loads</td> </tr> </table>			C	E.	Hazardous Waste / Liquids / Yard Waste / Other Materials Prohibited for Disposal	C	F.	Random / Suspicious Load Records	C	G.	Load Inspection During Evaluation	0	# of Loads Inspected	0 yds. Volume of Loads	<i>Daily / Interim / Final Cover</i>		
			C	E.	Hazardous Waste / Liquids / Yard Waste / Other Materials Prohibited for Disposal												
			C	F.	Random / Suspicious Load Records												
			C	G.	Load Inspection During Evaluation												
			0	# of Loads Inspected	0 yds. Volume of Loads												
			C	O.	Adequacy of Daily Cover												
Yes	P.	Are Alternate Daily Cover Materials Used?															
Yes	Q.	Is the Use in Compliance with Approved Plan?															
C	R.	Period and Adequacy of Interim Cover															
Yes	S.	Are all lifts exposed for 90 days covered with interim cover?															
C	T.	Completion of Area / Final Cover															
C	H.	Operations Conform to Permit, License, Order Conditions & Construction Certifications															
C	I.	Operations Conform to Approved Hydrogeo, Monitoring, Engineering and Operational Plans															
<b>REMARKS:</b>																	
<p>Inspection was carried out onsite, but in separate vehicles via phone in order to comply with COVID-19 health guidelines Documents were not reviewed onsite, but electronically via email.</p>																	
<b>Person Interviewed</b> Derek Neal		<b>Date of Inspection</b> 6/26/2020		<b>Time of Inspection</b> 2:00 PM													
<b>Inspected By</b> Evin Maguire		<b>Representing</b> EGLE-MMD															

**Michigan Department of Environmental Quality  
TYPE II LANDFILL OPERATING RECORD  
Evaluation Report**

**LEGEND: (C) = Compliance (V) = Violation (NE) = Not Evaluated ( \* ) = See Note (--) = Does not Apply**

C	A	Location Restriction Demonstrations	<b>REMARKS:</b>
C	B	Prohibited Waste Procedures	
C	C	Gas Monitoring Results	
C	D	Leachate, SCS Liquid and/or Gas Condensate Reintroduction Documentation	
C	E	LCS Monitoring Records	
C	F	SCS Monitoring Records	
C	G	Groundwater Monitoring Results	
C	H	Quantity of Waste Received	
C	I	Documentation of Placement of Interim Cover	
C	J	Closure Plans	
C	K	Post Closure Care Plans	
C	L	Groundwater Monitoring System Documentation	
C	M	Groundwater Sampling and Analysis Plan Documentation	
C	N	Statistical Procedures for Groundwater Monitoring	
C	O	Specific Procedures for Hydraulic Conductivity Testing for Cohesive Soils	
<b>REQUIRED BY</b>			
A	299.4438(1)(a)	B	299.4438(1)(b)
C	299.4438(1)(c)	D	299.4438(1)(d)
E	299.4438(1)(e)	F	299.4438(1)(f) & 299.4432(2)
G	299.4438(1)(g)	H	299.4438(1)(g) & 299.4432(4)
I	299.4438(1)(i)	J	299.4438(1)(j) & 299.4429(7)
K	299.4438(1)(k)	L	299.4438(1)(l)
M	299.4438(1)(m)	N	299.4438(1)(n)
O	299.4438(1)(o)	P	299.4438(1)(p) & 299.4920(2)
<b>Name of Facility</b> Citizens Disposal Landfill		<b>Date of Inspection</b> 9/24/19	<b>Time of Inspection</b> 1:00 pm
<b>Inspected By</b> Steve Blayer		<b>Representing</b> MDEQ - RMD	

## OPERATING RECORD REQUIREMENTS

<b>A. Location Restriction Demonstrations for:</b>	<b>G. Ground Water Monitoring Results</b>
<input checked="" type="checkbox"/> Groundwater Isolation	<i>Downgradient &amp; Background Groundwater Quality</i>
<input checked="" type="checkbox"/> Horizontal Isolation	<input checked="" type="checkbox"/> i. Primary Indicators + pH (Rule 450)
<input checked="" type="checkbox"/> Sensitive Areas	<input checked="" type="checkbox"/> ii. Heavy Metals (Rule 452)
<input checked="" type="checkbox"/> Airports	<input checked="" type="checkbox"/> iii. Primary Volatile Organics (Rule 453)
<input checked="" type="checkbox"/> Floodplains	<input checked="" type="checkbox"/> iv. Secondary Organics (Rule 454)
<input checked="" type="checkbox"/> Wetlands	<input checked="" type="checkbox"/> Notice of Statistically Significant Change from Background
<input checked="" type="checkbox"/> Fault Areas and Seismic Impact Zones	<input checked="" type="checkbox"/> Assessment Monitoring Plan
<input checked="" type="checkbox"/> Unstable Areas	<input checked="" type="checkbox"/> i. Notice of Constituent Levels above Groundwater Protection Standards
<input checked="" type="checkbox"/> Vertical Expansion Exemption	<input checked="" type="checkbox"/> ii. Response Action Plan
	<input checked="" type="checkbox"/> iii. Assessment of Corrective Measures
<b>B. Prohibited Waste Procedures</b>	<input checked="" type="checkbox"/> iv. Remedial Action Plan
<input checked="" type="checkbox"/> Random and Suspicious Load Inspection Records	<input checked="" type="checkbox"/> v. Notice of Implementation of Remedial Action Plan
<input checked="" type="checkbox"/> Training Procedures for Employees	
<input checked="" type="checkbox"/> Notification Procedures for Hazardous Waste Discovery	<b>H. Records of the Quantity of Waste Received</b>
	<input checked="" type="checkbox"/> [For Perpetual Care Fund]
<b>C. Gas Monitoring Information</b>	
<input checked="" type="checkbox"/> Gas Monitoring Results	<b>I. Documentation for the Placement of Interim Cover</b>
<input checked="" type="checkbox"/> Notice of Exceedance	<input checked="" type="checkbox"/> [Must be 1' Soil including Daily Cover or FML]
<input checked="" type="checkbox"/> Remediation Plan (if Gas Levels Exceeded.)	
	<b>J. Closure Plans</b>
<b>D. Leachate, Secondary Collection System (SCS) Liquid and/or Gas Condensate Reintroduction Design Documentation</b>	An Engineering Plan in Compliance with Rule 446 [Until the Unit is Officially Certified Closed]
<input checked="" type="checkbox"/> (As required in Operating License)	<input checked="" type="checkbox"/> Notice of the Intent to Close a Unit
	<input checked="" type="checkbox"/> Approved Closure Certification
<b>E. Leachate Collection System (LCS) Monitoring Records</b>	
<input checked="" type="checkbox"/> Weekly Leachate Depths	<b>K. Post Closure Care Plan</b>
<input checked="" type="checkbox"/> Monthly Volume Pumped from each Unit	<input checked="" type="checkbox"/> An Engineering Plan in Compliance with Rule 447
<i>Leachate Quality</i>	<input checked="" type="checkbox"/> Approved Post Closure Certification
<input checked="" type="checkbox"/> i. Primary Inorganic Indicators (Rule 450)	
<input checked="" type="checkbox"/> ii. Primary Volatile Organics (Rule 453)	<b>L. Groundwater Monitoring System Documentation</b>
<input checked="" type="checkbox"/> iii. Other Constituents (Rules 451 & 452)	<input checked="" type="checkbox"/> Design Documentation
<input checked="" type="checkbox"/> LCS Pipe Cleanout and Inspection Data	<input checked="" type="checkbox"/> Installation Documentation
	<input checked="" type="checkbox"/> Development Documentation
<b>F. SCS Monitoring Records</b>	<input checked="" type="checkbox"/> Decommission Documentation
<input checked="" type="checkbox"/> Weekly Liquid Volumes Removed from each Unit	<input checked="" type="checkbox"/> Approval of Groundwater Monitoring System
Average Daily Flow Rate in gal/acre/day	
<input checked="" type="checkbox"/> [Calculated Weekly, Monthly, and Quarterly]	<b>M. Groundwater Sampling and Analysis Plan Documentation</b>
<i>SCS Liquid Quality</i>	<input checked="" type="checkbox"/> Sampling and Analysis Plan
<input checked="" type="checkbox"/> i. Primary Inorganic Indicators (Rule 450)	
<input checked="" type="checkbox"/> ii. Primary Volatile Organics (Rule 453)	<b>N. Statistical Procedures for Groundwater Monitoring</b>
<input checked="" type="checkbox"/> iii. Other Constituents (Rules 451 & 452)	<input checked="" type="checkbox"/> The Statistical Method for Groundwater Analysis
<input checked="" type="checkbox"/> SCS Pipe Cleanout and Inspection Data	<input checked="" type="checkbox"/> Justification if the Test is Different from Rule 908
	<b>O. Specific Procedures for Hydraulic Conductivity Testing</b>
	<input checked="" type="checkbox"/> The Specific Procedures for Testing Cohesive Soils



**CITY OF FLINT PROPOSAL NO.21000605**

**Sewage Sludge Cake Disposal and Transport Services**

**THE FOLLOWING PAGES MUST BE COMPLETED AND INCLUDED WITH SUBMITTAL  
IN THE FOLLOWING ORDER.**

**Purchasing Checklist:**

- Cover Sheet
- Exhibit A – Bid Form Submittal
- Exhibit B – List of References
- Exhibit C – Certificate of Insurance
- Exhibit D - Non-Bidder's Response
- City of Flint, Michigan Affidavit



March 24, 2021

Joyce A. McClane  
City of Flint  
Finance Department-Purchases and Supplies  
1101 S Saginaw St., Room 203, 2<sup>nd</sup> Floor  
Flint, MI 48502

Re. Proposal # 21000605

Dear Ms. McClane:

Attached is Waste Management's proposal that we have prepared for City of Flint.

Based on a comprehensive evaluation of City of Flint's waste streams, service requirements and budgetary parameters, the proposed program contains solutions designed to strengthen City of Flint's operations, address compliance issues and enhance the overall business environment. It is designed to deliver those specific benefits you have identified as most important to City of Flint.

Waste Management appreciates the business relationship that we have had for several years as your current provider of this service. We are hopeful that we will be selected as the successful bidder in this new bid package. A completed Certificate of Insurance will be provided to the City with an award.

Waste Management would like to discuss the benefits of this proposal and other value-added synergies between our companies. We look forward to working with your team on this project and establishing a business relationship structured to meet your long-term goals.

We would like to discuss the details of our recommended service plan, obtain your feedback and discuss implementation procedures. In the meantime, please call me at 248 640 8338 if you have any questions.

Sincerely,

A handwritten signature in black ink, appearing to read 'Kevin Beste'.

Kevin Beste  
Industrial Account Manager  
Waste Management  
248 640 8338

**BID SUBMITTAL FORM**

**EXHIBIT A**

**Biosolids (Landfill) Disposal Contract**

**BID FORM**

<b>BIDDER Name and Address</b>		Waste Management of Michigan - People's Landfill 4143 Rathbun Rd Birch Run, MI 48415		
<b>Landfill (Sludge Disposal) Hours of Operation</b>		<b>YEAR 1</b> 7/1/21 to 6/30/22	<b>YEAR 2</b> 7/1/22 to 6/30/23	<b>YEAR 3</b> 7/1/23 to 6/30/24
		<b>Total cost per ton</b>	<b>Total cost per ton</b>	<b>Total cost per ton</b>
Monday thru Friday		\$ 38.50	\$ 40.40	\$ 42.43
Saturday		closed	closed	closed
Holidays		closed	closed	\$ closed
<b>TOTAL COST 13,000 Tons per fiscal year</b>		<b>\$ 500,000.00</b>	<b>\$ 525,200.00</b>	<b>\$ 551,590.00</b>

*LB*

**Biosolids Transportation Contract**  
**YEAR 1 BID FORM**  
**July 1, 2021 to June 30, 2022**

<b>BIDDER Name and Address</b>	Waste Management of Michigan - People's Landfill 4143 Rathbun Rd Birch Run, MI 48415			
<b>LANDFILL</b>	<b>Republic Citizens Grand Blanc</b>	<b>Brent Run Montrose</b>	<b>Venice Park Lennon</b>	<b>Waste Management Birch Run</b>
<b>LOCATION</b>	2361 W Grand Blanc RD Grand Blanc MI 48439	8335 Vienna RD Montrose MI 48457	9536 E Lennon RD Lennon MI 48449	4143 East Rathbun RD Birch Run, MI 48415
<b>DISTANCE, Miles Travel Time</b>	<b>10.2 12 minutes</b>	<b>15.0 17 minutes</b>	<b>13.8 19 minutes</b>	<b>21.3 29 minutes</b>
<b>Cost per ton, per mile General rate</b>	<b>Cost per ton</b>			
<b>\$</b>	\$ no bid	\$ no bid	\$ no bid	\$ no bid

*Handwritten initials/signature*

**Biosolids Transportation Contract  
YEAR 2 BID FORM**

**July 1, 2022 to June 30, 2023**

<b>BIDDER Name and Address</b>	Waste Management of Michigan People's Landfill 4143 Rathbun Rd Birch Run, MI 48415			
<b>LANDFILL</b>	<b>Republic Citizens Grand Blanc</b>	<b>Brent Run Montrose</b>	<b>Venice Park Lennon</b>	<b>Waste Management Birch Run</b>
<b>LOCATION</b>	2361 W Grand Blanc RD Grand Blanc MI 48439	8335 Vienna RD Montrose MI 48457	9536 E Lennon RD Lennon MI 48449	4143 East Rathbun RD Birch Run, MI 48415
<b>DISTANCE, Miles Travel Time</b>	<b>10.2</b> 12 minutes	<b>15.0</b> 17 minutes	<b>13.8</b> 19 minutes	<b>21.3</b> 29 minutes
<b>Cost per ton, per mile General rate</b>	<b>Cost per ton</b>			
\$	\$ no bid	\$ no bid	\$ no bid	\$ no bid

125

## Biosolids Transportation Contract YEAR 3 BID FORM

July 1, 2023 to June 30, 2024

<b>BIDDER Name and Address</b>	Waste Management of Michigan - People's Landfill 4143 Rathbun Rd Birch Run, MI 48415			
<b>LANDFILL</b>	<b>Republic Citizens Grand Blanc</b>	<b>Brent Run Montrose</b>	<b>Venice Park Lennon</b>	<b>Waste Management Birch Run</b>
<b>LOCATION</b>	2361 W Grand Blanc RD Grand Blanc MI 48439	8335 Vienna RD Montrose MI 48457	9536 E Lennon RD Lennon MI 48449	4143 East Rathbun RD Birch Run, MI 48415
<b>DISTANCE, Miles Travel Time</b>	<b>10.2</b> 12 minutes	<b>15.0</b> 17 minutes	<b>13.8</b> 19 minutes	<b>21.3</b> 29 minutes
<b>Cost per ton, per mile General rate</b>	<b>Cost per ton</b>			
\$	\$ no bid	\$ no bid	\$ no bid	\$ no bid

1. Failure to use this bid form shall result in bid disqualification.
2. Failure to bid on all items shall result in an "incomplete bid" determination.
3. List value-added considerations on a separate sheet of paper.

Terms: net 30 Fed. ID#: 28-1214786

Firm Name: Waste Management of Michigan, Inc.

Address: 4143 East Rathbun Rd

City/State/Zip Birch Run, MI 48415

Phone: 2486408338 Fax: n/a Email: kbeste@wm.com

Signed: \_\_\_\_\_ Date: March 23, 2021



FOR CORPORATION

STATE OF Michigan

S.S.

COUNTY OF Genesee

Kevin Beste being duly sworn, deposes and says that she/he/they  
is an Industrial Acct Mgr of Waste Management of Michigan, Inc.

(Official Title)

(Name of Corporation)

a corporation duly organized and doing business under the laws of the State of Michigan  
the corporation making the within and foregoing bid; that they executed said bid in behalf of said corporation by  
authority of its Board of Directors; that said bid is genuine and not sham or collusive and is not made in the  
interests of or on behalf of any person not herein named, and that they have not and said bidder has not directly  
or indirectly induced or solicited any other person or corporation to refrain from bidding; that they have not and  
said bidder has not in any manner sought by collusion to secure to themselves or to said corporation an advantage  
over other bidders.

Subscribed and sworn to before me at Flint, Michigan, in said County and State,

this 24th day of March, A.D. 20 21

Bethany Yerk

\*Notary Public, Genesee County, Michigan

My Commission expires March 8, 2023

NOTE: If executed outside of the State of Michigan, certificate by the Clerk of the Court of Record, authenticating the Notary's Signature and authority should be attached.

BETHANY YERK  
NOTARY PUBLIC - STATE OF MICHIGAN  
COUNTY OF LAPEER  
My Commission Expires March 8, 2023  
Acting in the County of Genesee

**CITY OF FLINT, MICHIGAN AFFIDAVIT**

**AFFIDAVIT FOR INDIVIDUAL**

STATE OF Michigan

S.S.

COUNTY OF Genesee

Kevin Beste being duly sworn,  
deposes and says that they are the person making the above bid; and that said bid is genuine and not sham or collusive, and is not made in the interest of or on behalf of any person not therein named, and that they have not directly or indirectly induced or solicited any bidder to put in a sham bid; that they have not directly or indirectly induced or solicited any other person or corporation to refrain from bidding, and that they have not in any manner sought by collusion to secure themselves any advantage over other bidders.

Subscribed and sworn to before me at Flint, Michigan, in said County and State,

this 24th day of March, A.D. 20 21

Bethany Yerk

\*Notary Public, Genesee County, Michigan

My Commission expires March 8, 2023

*NOTE: If executed outside of the State of Michigan, certificate by the Clerk of the Court of Record, authenticating the Notary's Signature and authority should be attached.*

**BETHANY YERK**  
**NOTARY PUBLIC - STATE OF MICHIGAN**  
**COUNTY OF LAPEER**  
My Commission Expires March 8, 2023  
Acting in the County of Genesee



**EXHIBIT D**

*Sewage Sludge Cake Disposal and Transport Services*

**NON-BIDDER'S RESPONSE**

**VENDORS NAME:** \_\_\_\_\_

For the purpose of facilitating your firm's response to our invitation to bid, the City of Flint is interested in ascertaining reasons for prospective bidder's failure to respond to "Invitations to Bid". If your firm is not responding to this bid, please indicate the reason(s) by checking any appropriate item(s) below and return this form to the above address.

We are *not* responding to this "Invitation to Bid" for the following reason(s):

\_\_\_\_\_ Items or materials requested not manufactured by us or not available to our company.

\_\_\_\_\_ Our items and/or materials do not meet specifications.

\_\_\_\_\_ Specifications not clearly understood or applicable (too vague, too rigid, etc.).

\_\_\_\_\_ Quantities too Small.

\_\_\_\_\_ Insufficient time allowed for preparation of bid.

\_\_\_\_\_ Incorrect address used. Our correct mailing address is: \_\_\_\_\_

\_\_\_\_\_

\_\_\_\_\_ Our branch / division handles this type of bid. We have forwarded this bid on to them but for the future the correct name and mailing address is: \_\_\_\_\_

\_\_\_\_\_ **OTHER:** \_\_\_\_\_

\_\_\_\_\_

**Thank you for your participation in this bid.**

## **EXHIBIT C**

### *Sewage Sludge Cake Disposal and Transport Services*

## **CERTIFICATE OF INSURANCE**

### **INSURANCE REQUIREMENTS**

The Contractor shall notify all insurance agents and companies retained by the Contractor that these insurance requirements shall be included in any Agreement between the Contractor and the City of Flint.

The Contractor shall purchase and maintain, at its sole expense and as long as it is providing services to the City, the following insurance coverage:

**Commercial General Liability - Occurrence form, including coverage for bodily injury, personal injury, property damage (broad form), premises/operations, blanket contractual, and products/completed operations. Coverage shall be endorsed to include the City as an additional insured for work performed by the Contractor in accordance with the Agreement.**

#### **Minimum Limits:**

- \$1,000,000 per occurrence/\$2,000,000 general aggregate
- \$2,000,000 aggregate for products and completed operations
- \$1,000,000 personal and advertising injury

**Automobile - Michigan "no-fault" coverage, and residual automobile liability, comprehensive form, covering owned, hired, and non-owned automobiles. Coverage shall be endorsed to include the City as an additional insured for work performed by the Contractor in accordance with the Agreement.**

#### **Minimum Limits:**

- No-fault coverages - statutory
- \$500,000 per person/\$1,000,000 per accident - bodily injury
- \$500,000 per occurrence - property damage
- A combined single limit of \$1,000,000 per occurrence

**Workers' Compensation and Employer's Liability- Statutory coverage or proof acceptable to the City of approval as a self-insurer by the State of Michigan.**

## **EXHIBIT C**

### *Sewage Sludge Cake Disposal and Transport Services*

#### **CERTIFICATE OF INSURANCE (continues)**

##### **Minimum Limits:**

- **Workers' Compensation - statutory**
- **Employer's Liability - \$100,000 each accident/\$100,000 disease - each employee**
- **\$500,000 disease - policy limit**

**Professional Liability –** Covering acts, errors or omissions of a professional nature committed or alleged to have been committed by the Contractor or any of its subcontractors. Coverage shall be effective upon the date of the Agreement and shall remain effective for a period of three (3) years after the date of final payment thereunder. Such coverage shall be endorsed to include any subcontractors hired by the City.

##### **Minimum Limits:**

- **\$1,000,000 per occurrence, \$1,000,000 annual aggregate**

Insurance coverage shall cover all claims against the City of Flint, its officials and employees, arising out of the work performed by the Contractor or any subcontractors under the Agreement. Should any work be subcontracted, it shall be the responsibility of the Contractor to maintain Independent Contractor's Protective Liability Insurance with limits equal to those specified above for Commercial General Liability Insurance. In addition, the Contractor shall provide proof of Workers' Compensation Insurance for all subcontractors in compliance with the required statutory limits of the State of Michigan.

Said policies of insurance shall be with companies licensed to do business in the State of Michigan and in a form satisfactory to the City. All insurance companies must maintain a rating of B+, VIII or better from AM. Best Company. Certificates of insurance with a thirty-(30) day cancellation clause shall be filed with and approved by the City at least five (5) days in advance of commencing work under the Agreement. Cancellation, material restriction, non-renewal or lapse of any of the required policies shall be grounds for immediate termination of the Agreement by the City.

The City reserves the right to request a complete certified copy of the policies for the above coverage's.

Any reduction or exhaustion in the limits of required insurance coverage shall not be deemed to limit the indemnification afforded in accordance with the Agreement or any amendments thereto.

Depending on the subject matter of the transaction, the City may require other insurance coverage in addition to the coverage's contained herein.

**THE BID NUMBER IS TO APPEAR ON ALL INSURANCE CERTIFICATES**

**EXHIBIT B**

*Sewage Sludge Cake Disposal and Transport Services*

**LIST OF REFERENCES: (3) SIMILAR SCOPE OF WORK FROM THE LAST 5 YEARS**

Providing the following contact information enables the City of Flint to contact those accounts as references.

**Reference #1:**

Company/Municipality: City of Mount Clemens

Contact Person: Jason Pich Title: Plant Superintendant

Address: 1750 Clara St

City: Mt Clemens State: MI Zip:

Telephone: 586 707 2979 Fax:

Email: jpich@cityofmountclemens.com

Type of Project: Bio Solids solidification and hauling

Project Timeline (Dates): 3 years Budget: \$100,000

**Reference #2:**

Company/Municipality: City of Wyandotte

Contact Person: Jason Tapp Title: Plant Manager

Address: 797 Central

City: Wyandotte State: MI Zip: 48192

Telephone: 313-590-3509 Fax:

Email: jason.tapp@veolia.com

Type of Project: sludge hauling

Project Timeline (Dates): 5 years Budget: 1,000,000.00

**EXHIBIT B**

*Sewage Sludge Cake Disposal and Transport Services*

**LIST OF REFERENCES: (3) SIMILAR SCOPE OF WORK FROM THE LAST 5 YEARS (continues)**

**Reference #3:**

Company/Municipality: Bio Tech Agrnomics

Contact Person: Don Popma Title: General Manager

Address: \_\_\_\_\_

City: Beulah State: MI Zip: 49617

Telephone: 616 835 0100 Fax: \_\_\_\_\_

Email: dpopma@biotechag.com

Type of Project: bio solids management

Project Timeline (Dates): 5 years Budget: 2,000,000.00



December 15, 2020

Terry Nichols  
Peoples Landfill, Inc.  
4143 E. Rathbun Road  
Birch Run, MI 48415

RE: Quarterly Inspection  
Peoples Garbage Disposal  
Facility #437908  
4143 E. Rathbun Road  
Taymouth Township  
Saginaw County, Michigan

Dear Mr. Nichols:

On December 11, 2020, this writer representing the Saginaw County Health Department conducted a quarterly inspection at the above captioned location. The purpose of the inspection was to evaluate compliance of the facility with the requirements of Part 115 of the Natural Resources and Environmental Protection Act P.A. 451 of 1994, as amended, and the rules promulgated pursuant to Part 115

At the time of the inspection, no operational violations were noted. Enclosed is a copy of the inspection report for your records.

Should you have any questions, please feel free to contact this office at (989) 758-3685.

Sincerely,

For Christina A. Harrington, M.P.H.  
Health Office

Jerry Maxson, R.E.H.S.  
Environmental Health Specialist III

JWM:afh

Enclosure

c: Lori Babcock, EGLE - MMD  
Saginaw County Planning Department  
Taymouth Township Supervisor

**Michigan Department of Environmental Quality  
Waste Management and Radiological Protection Division  
Part 115 - Landfill Evaluation Report**

<b>Name of Facility</b> People's Landfill, Inc.		<b>Facility Number</b> 437908		<b>License # and Expiration Date</b> 9480      7/28/2021																			
<b>Facility Address</b> 4143 E. Rathbun Rd.		<b>Facility Contact: Name -- Phone Number</b> Mr. Terry Nichols      (989) 777-1145																					
<b>LEGEND: (C) = Compliance (V) = Violation (NE) = Not Evaluated (* ) = See Note (-) = Does not Apply</b>																							
<i>General Operations</i>			<i>Leachate / Stormwater Mangement</i>																				
C	A.	Miscellaneous Operational Issues	C	J.	Surface Water Discharge																		
C	B.	Blowing Debris, Dust, Odor & Vector Control	C	K.	Protection of Surface Waters																		
C	C.	Gas Monitoring & Migration	C	L.	Leachate Control / Mangement																		
No	D.	Are there any exceedances of the LEL?	C	M.	Leachate Volume / Head Records																		
<i>Prohibited Waste Restrictions</i>			--	N.	Secondary Volume / ARF / RFR Records																		
<table border="1" style="width: 100%; border-collapse: collapse;"> <tr> <td>C</td> <td>E.</td> <td>Hazardous Waste / Liquids / Yard Waste / Other Materials Prohibited for Disposal</td> </tr> <tr> <td>C</td> <td>F.</td> <td>Random / Suspicious Load Records</td> </tr> <tr> <td>NE</td> <td>G.</td> <td>Load Inspection During Evaluation</td> </tr> <tr> <td colspan="3" style="text-align: center;"><i>Permit and License Compliance</i></td> </tr> <tr> <td>C</td> <td>H.</td> <td>Operations Conform to Permit, License, Order Conditions &amp; Construction Certifications</td> </tr> <tr> <td>C</td> <td>I.</td> <td>Operations Conform to Approved Hydrogeo, Monitoring, Engineering and Operational Plans</td> </tr> </table>			C	E.	Hazardous Waste / Liquids / Yard Waste / Other Materials Prohibited for Disposal	C	F.	Random / Suspicious Load Records	NE	G.	Load Inspection During Evaluation	<i>Permit and License Compliance</i>			C	H.	Operations Conform to Permit, License, Order Conditions & Construction Certifications	C	I.	Operations Conform to Approved Hydrogeo, Monitoring, Engineering and Operational Plans	<i>Daily / Interim / Final Cover</i>		
			C	E.	Hazardous Waste / Liquids / Yard Waste / Other Materials Prohibited for Disposal																		
C	F.	Random / Suspicious Load Records																					
NE	G.	Load Inspection During Evaluation																					
<i>Permit and License Compliance</i>																							
C	H.	Operations Conform to Permit, License, Order Conditions & Construction Certifications																					
C	I.	Operations Conform to Approved Hydrogeo, Monitoring, Engineering and Operational Plans																					
			C	O.	Adequacy of Daily Cover																		
			No	P.	Are Alternate Daily Cover Materials Used?																		
				Q.	Is the Use in Compliance with Approved Plan?																		
# of Loads Inspected      yds. Volume of Loads			C	R.	Period and Adequacy of Interim Cover																		
			Yes	S.	Are all lifts exposed for 90 days covered with interim cover?																		
			C	T.	Completion of Area / Final Cover																		
<b>REMARKS:</b>																							
<b>Person Interviewed</b> Terry Nichols		<b>Date of Inspection</b> 12/11/2020		<b>Time of Inspection</b> 2:50 p.m.																			
<b>Inspected By</b> Jerry Maxson		<b>Representing</b> EGLE - MMD																					

**DEFINITIONS**





PROPOSAL# 21000605

RESOLUTION NO.: 210264

PRESENTED: JUN - 6 2021

ADOPTED: \_\_\_\_\_

BY THE CITY ADMINISTRATOR:

**RESOLUTION TO DHT TRANSPORTATION FOR SEWAGE SLUDGE TRANSPORT SERVICES**

WHEREAS, Water Pollution Control (WPC) generates approximately 13,000 wet tons of biosolids cake and grit ("residuals") from its wastewater treatment process annually. Residuals must be transported off plant site to a landfill or other disposal site every weekday. The services are to be provided with fixed rates, for a period of three fiscal years. The contracts will be in effect for FY2022, FY2023, and FY2024. Three bids were reviewed and a split award is recommended.

WPC recommends the lowest qualified bidder, DHT Transportation be awarded the bid for transportation services in the amount of \$250,000 for each of the next three fiscal years FY2022, FY2023, and FY2024, totaling \$750,000.

Account Number	Account Name	Amount
590-550.100-801.500	Sludge Disposal Services	\$250,000.00
	<b>FY2022 GRAND TOTAL</b>	<b>\$250,000.00</b>

IT IS RESOLVED, that the appropriate City Officials are authorized to do all things necessary to enter into a contract with DHT Transportation to provide sludge disposal transportation services for FY2022, pending budget adoption, for the amount of \$250,000.00.

APPROVED AS TO FORM:

Angela Wheeler  
Angela Wheeler (May 24, 2021 09:10 EDT)  
**Angela Wheeler, Chief Legal Officer**

APPROVED AS TO FINANCE:

Shelbi Frayer  
shelbi frayer (May 23, 2021 10:28 EDT)  
**Shelbi Frayer, Chief Financial Officer**

FOR THE CITY OF FLINT:

Clyde D. Edwards  
Clyde D. Edwards (May 24, 2021 14:42 EDT)  
**Clyde Edwards, City Administrator**

APPROVED BY CITY COUNCIL:

\_\_\_\_\_  
**Kate Fields, City Council President**

APPROVED AS TO PURCHASING:

Jennifer Ryan  
Jennifer Ryan (May 23, 2021 15:21 EDT)  
**Jenn Ryan, Deputy Finance Director**



# CITY OF FLINT

## RESOLUTION STAFF REVIEW FORM

**TODAY'S DATE:** 03/12/2021

**BID/PROPOSAL#:** Proposal 21000605

**AGENDA ITEM TITLE:** Sewage Sludge Cake Disposal and Transport Services

**PREPARED BY:** Krystal Wallace  
Water Pollution Control

**VENDOR NAME:** Republic Services for Cake Disposal  
DHT Transportation for Transport Services

**BACKGROUND/SUMMARY OF PROPOSED ACTION:**

Water Pollution Control (WPC) generates approximately 13,000 wet tons of biosolids cake and grit ("residuals") from its wastewater treatment process annually. Residuals must be transported off plant site to a landfill or other disposal site every weekday. The services are to be provided with fixed rates, for a period of three fiscal years. The Contracts will be in effect for FY2022, FY2023, and FY2024. Three Bids were reviewed and a split award is recommended.

WPC recommends the lowest qualified bidder; DHT Transportation be awarded the bid for transportation services in the amount of \$250,000.00 for each of the next three fiscal years, FY 2022, 2023, & 2024, a three-(3) year total of \$750,000.00.

WPC also recommends the lowest qualified bidder; Republic Services be awarded the three year bid for Disposal Services (Landfill) services in the amount of \$247,000.00 (FY 2022), \$260,000.00 (FY2023), and \$273,000.00 (FY 2024), a three-(3) year total of \$780,000.00.

Amounts are pending approval and adoption of each respective fiscal year.

**FINANCIAL IMPLICATIONS:** None

**BUDGETED EXPENDITURE?** YES  NO  IF NO, PLEASE EXPLAIN:

Dept.	Name of Account	Account Number	Grant Code	Amount
DPW-WPC	Sludge Disposal Services	590-550.100-801.500		\$250,000.00
DPW-WPC	Sludge Disposal Services	590-550.100-801.500		\$247,000.00
<b>FY2022 GRAND TOTAL</b>				<b>\$497,000.00</b>



**CITY OF FLINT**

**PRE-ENCUMBERED?** YES  NO  **REQUISITION NO:** 210004067 and 210004503

**ACCOUNTING APPROVAL:** \_\_\_\_\_ **Date:** \_\_\_\_\_

**WILL YOUR DEPARTMENT NEED A CONTRACT?** YES  NO   
*(If yes, please indicate how many years for the contract)* YEARS

**WHEN APPLICABLE, IF MORE THAN ONE (1) YEAR, PLEASE ESTIMATE TOTAL AMOUNT FOR EACH BUDGET YEAR: (This will depend on the term of the bid proposal)**

	Transport	Disposal
<b>BUDGET YEAR 1</b>	\$250,000.00 &	\$247,000.00
<b>BUDGET YEAR 2</b>	\$250,000.00 &	\$260,000.00
<b>BUDGET YEAR 3</b>	\$250,000.00 &	\$273,000.00

**OTHER IMPLICATIONS (i.e., collective bargaining):** None.

**STAFF RECOMMENDATION: (PLEASE SELECT):**  **APPROVED**  **NOT APPROVED**

**DEPARTMENT HEAD SIGNATURE:** \_\_\_\_\_  
*Jeanette H. Best*  
**(Jeanette Best, WPC Manager)**

Waste Management				
Landfill (Sludge Disposal)	YEAR 1	YEAR 2	YEAR 3	
	7/1/21 to 6/30/22	7/1/22 to 6/30/23	7/1/23 to 6/30/24	
Hours of Operation	Total cost per ton	Total cost per ton	Total cost per ton	Total cost per ton
Monday thru Friday	\$ 38.50	\$ 40.40	\$ 42.43	
Saturday	Closed	Closed	Closed	
Holidays	Closed	Closed	Closed	
<b>TOTAL COST</b>	<b>\$ 500,500.00</b>	<b>\$ 525,200.00</b>	<b>\$ 551,590.00</b>	
13,000 Tons per fiscal year				

Republic Services				
Landfill (Sludge Disposal)	YEAR 1	YEAR 2	YEAR 3	
	7/1/21 to 6/30/22	7/1/22 to 6/30/23	7/1/23 to 6/30/24	
Hours of Operation	Total cost per ton	Total cost per ton	Total cost per ton	Total cost per ton
Monday thru Friday	\$ 19.00	\$ 20.00	\$ 21.00	
Saturday	\$ 19.00	\$ 20.00	\$ 21.00	
Holidays	\$ 30.00	\$ 32.00	\$ 33.00	
<b>TOTAL COST</b>	<b>\$ 247,000.00</b>	<b>\$ 260,000.00</b>	<b>\$ 273,000.00</b>	
13,000 Tons per fiscal year				

DHT Transport Services				
Landfill (Sludge Disposal)	YEAR 1	YEAR 2	YEAR 3	
	7/1/21 to 6/30/22	7/1/22 to 6/30/23	7/1/23 to 6/30/24	
Hours of Operation	Total cost per ton	Total cost per ton	Total cost per ton	Total cost per ton
Monday thru Friday	\$	\$	\$	
Saturday	\$	\$	\$	
Holidays	\$	\$	\$	
<b>TOTAL COST</b>	<b>No Bid</b>	<b>No Bid</b>	<b>No Bid</b>	
13,000 Tons per fiscal year				

Transport to Landfill	Republic Citizens	Brent Run	Venice Park	Waste Management
	Grand Blanc	Montrose	Lennon	Birch Run
LOCATION	2361 W Grand Blanc Rd Grand Blanc MI 48439	8335 Vienna Rd Montrose MI 48457	9538 E Lennon Rd Lennon MI 48449	4143 East Rabbitun Rd Birch Run MI 48415
DISTANCE, Miles	10.2	15	13.8	21.3
Travel Time	12 minutes	17 minutes	19 minutes	29 minutes
Cost per ton, per mile				
FISCAL Year				
General rate				
FY 22	N/A	No Bid	No Bid	No Bid
FY 23	N/A	No Bid	No Bid	No Bid
FY 24	N/A	No Bid	No Bid	No Bid

Transport to Landfill	Republic Citizens	Brent Run	Venice Park	Waste Management
	Grand Blanc	Montrose	Lennon	Birch Run
LOCATION	2361 W Grand Blanc Rd Grand Blanc MI 48439	8335 Vienna Rd Montrose MI 48457	9538 E Lennon Rd Lennon MI 48449	4143 East Rabbitun Rd Birch Run MI 48415
DISTANCE, Miles	10.2	15	13.8	21.3
Travel Time	12 minutes	17 minutes	19 minutes	29 minutes
Cost per ton, per mile				
FISCAL Year				
General rate				
FY 22	N/A	No Bid	No Bid	No Bid
FY 23	N/A	No Bid	No Bid	No Bid
FY 24	N/A	No Bid	No Bid	No Bid

Transport to Landfill	Republic Citizens	Brent Run	Venice Park	Waste Management
	Grand Blanc	Montrose	Lennon	Birch Run
LOCATION	2361 W Grand Blanc Rd Grand Blanc MI 48439	8335 Vienna Rd Montrose MI 48457	9538 E Lennon Rd Lennon MI 48449	4143 East Rabbitun Rd Birch Run MI 48415
DISTANCE, Miles	10.2	15	13.8	21.3
Travel Time	12 minutes	17 minutes	19 minutes	29 minutes
Cost per ton, per mile				
FISCAL Year				
General rate				
FY 22	N/A	\$ 455.00	\$ 455.00	\$ 500.00
FY 23	N/A	\$ 466.38	\$ 466.38	\$ 512.50
FY 24	N/A	\$ 478.04	\$ 478.04	\$ 525.31

Summary					
Vendor	Fiscal Year	Landfill	Sludge Transportation (Hauling) Per Trailer	Sludge Transportation (Hauling) Yearly Cost (Low)	Yearly Cost (High)
DHT Transportation	FY 2022	No Bid	\$ 455.00	\$ 236,600.00	\$ 260,000.00
	FY 2023	No Bid	\$ 466.38	\$ 242,517.60	\$ 266,500.00
	FY 2024	No Bid	\$ 478.04	\$ 248,580.80	\$ 273,161.20
Republic Services	FY 2022	\$ 247,000.00	\$ 475.00	\$ 247,000.00	\$ 247,000.00
	FY 2023	\$ 260,000.00	\$ 490.00	\$ 254,800.00	\$ 254,800.00
	FY 2024	\$ 273,000.00	\$ 500.00	\$ 260,000.00	\$ 260,000.00
Waste Management	FY 2022	\$ 500,500.00	No Bid	No Bid	No Bid
	FY 2023	\$ 525,200.00	No Bid	No Bid	No Bid
	FY 2024	\$ 551,590.00	No Bid	No Bid	No Bid

Summary					
Vendor	Fiscal Year	Landfill	Sludge Transportation (Hauling) Per Trailer	Sludge Transportation (Hauling) Yearly Cost (Low)	Yearly Cost (High)
DHT Transportation	FY 2022	No Bid	\$ 455.00	\$ 236,600.00	\$ 260,000.00
	FY 2023	No Bid	\$ 466.38	\$ 242,517.60	\$ 266,500.00
	FY 2024	No Bid	\$ 478.04	\$ 248,580.80	\$ 273,161.20
Republic Services	FY 2022	\$ 247,000.00	\$ 475.00	\$ 247,000.00	\$ 247,000.00
	FY 2023	\$ 260,000.00	\$ 490.00	\$ 254,800.00	\$ 254,800.00
	FY 2024	\$ 273,000.00	\$ 500.00	\$ 260,000.00	\$ 260,000.00
Waste Management	FY 2022	\$ 500,500.00	No Bid	No Bid	No Bid
	FY 2023	\$ 525,200.00	No Bid	No Bid	No Bid
	FY 2024	\$ 551,590.00	No Bid	No Bid	No Bid

Summary					
Vendor	Fiscal Year	Landfill	Sludge Transportation (Hauling) Per Trailer	Sludge Transportation (Hauling) Yearly Cost (Low)	Yearly Cost (High)
DHT Transportation	FY 2022	No Bid	\$ 455.00	\$ 236,600.00	\$ 260,000.00
	FY 2023	No Bid	\$ 466.38	\$ 242,517.60	\$ 266,500.00
	FY 2024	No Bid	\$ 478.04	\$ 248,580.80	\$ 273,161.20
Republic Services	FY 2022	\$ 247,000.00	\$ 475.00	\$ 247,000.00	\$ 247,000.00
	FY 2023	\$ 260,000.00	\$ 490.00	\$ 254,800.00	\$ 254,800.00
	FY 2024	\$ 273,000.00	\$ 500.00	\$ 260,000.00	\$ 260,000.00
Waste Management	FY 2022	\$ 500,500.00	No Bid	No Bid	No Bid
	FY 2023	\$ 525,200.00	No Bid	No Bid	No Bid
	FY 2024	\$ 551,590.00	No Bid	No Bid	No Bid

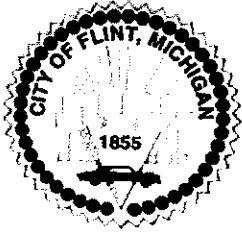

# City of Flint

## Department of Finance Division of Purchases & Supplies

---

Sheldon A. Neeley

March 25, 2021

**TO:** Michael Brown  
Jeanette Best

**FROM:** Joyce A. McClane  
Purchasing Manager

**SUBJECT:** SEALED BIDS

Attached are three (3) bids that were received for **PROPOSAL #21000605 – SEWAGE SLUDGE CAKE DISPOSAL AND TRANSPORT SERVICES**. Enclosed are copies for your file. **Bid Due Date: 3/24/21. Enclosed is a spreadsheet.**

Your staff review and recommendation form is needed as soon as possible. **Please use the new fillable form.** This form is to be used for your staff review.

A staff review must be completed for ALL **Bids/Proposals**. Please let me know if you need a copy of the fillable form.

**Please note:** If your project is being funded by any grants issued by the federal government, you must go to:  
<https://www.doi.gov/ofccp/regs/compliance/preaward/debarlst.htm> to ensure that the selected vendor has not been debarred.

**PLEASE NOTE:**

Results may be viewed next business day online EXCEPT when a bid is under review. The bidders/public will only see the names of the bidders that submitted a bid, not their cost. This will protect the bidders cost in case there is a re-bid.

**If you have any questions, please feel free to give me a call or send an email.**

  
Signature

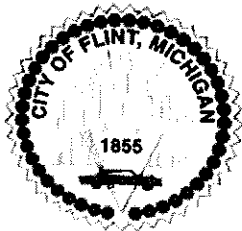

# City of Flint

## Department of Finance Division of Purchases & Supplies

---

Sheldon A. Neeley

Today's Date:

Please complete the following form if you decide to rebid:

**Proposal #**

**DETAILED REASON FOR WANTING TO REBID:**

--

**Authorized Signature and Title:**

**Date Signed**

.....  
**PURCHASING USE ONLY**

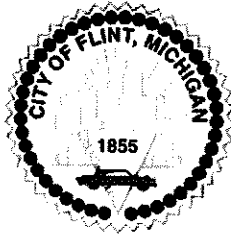

**SEALED PROPOSALS RECEIVED IN THE DIVISION OF PURCHASES & SUPPLIES**  
**For Sewage Sludge Cake Disposal & Transport Services**  
**PROPOSAL# 21000605**

Approximate Annual Quantities – Not Guaranteed  
 Furnish as requested for the period 7/1/20 – 6/30/21

## Biosolids (Landfill) Disposal Contract

### BID FORM

**Bidder #1: DHT Transport**  
**2695 W. Vassar Rd., Reese, MI 48757**

Landfill (Sludge Disposal) Hours of Operation		YEAR 1 7/1/21 to 6/30/22	YEAR 2 7/1/22 to 6/30/23	YEAR 3 7/1/23 to 6/30/24
		Total cost per ton	Total cost per ton	Total cost per ton
Monday thru Friday		\$ No Bid	\$ No Bid	\$ No Bid
Saturday		\$ No Bid	\$ No Bid	\$ No Bid
Holidays		\$ No Bid	\$ No Bid	\$ No Bid
<b>TOTAL COST 13,000 Tons per fiscal year</b>		\$ No Bid	\$ No Bid	\$ No Bid

**A SPECIAL NOTE FROM THE PURCHASING DIVISION**

*Bid results posted are before evaluation team review and award recommendation.*



**Biosolids Transportation Contract  
YEAR 1 BID FORM**

**[REDACTED]**

LANDFILL	Republic Citizens Grand Blanc	Brent Run Montrose	Venice Park Lennon	Waste Management Birch Run
LOCATION	2361 W Grand Blanc RD Grand Blanc MI 48439	8335 Vienna RD Montrose MI 48457	9536 E Lennon RD Lennon MI 48449	4143 East Rathbun RD Birch Run, MI 48415
DISTANCE, Miles Travel Time	10.2 12 minutes	15.0 17 minutes	13.8 19 minutes	21.3 29 minutes
Cost per ton, per mile General rate	Cost per ton Trailer			
\$ N/A	\$ 455.00	\$ 455.00	\$ 455.00	\$ 500.00

**Biosolids Transportation Contract  
YEAR 2 BID FORM**

**[REDACTED]**

LANDFILL	Republic Citizens Grand Blanc	Brent Run Montrose	Venice Park Lennon	Waste Management Birch Run
LOCATION	2361 W Grand Blanc RD Grand Blanc MI 48439	8335 Vienna RD Montrose MI 48457	9536 E Lennon RD Lennon MI 48449	4143 East Rathbun RD Birch Run, MI 48415
DISTANCE, Miles Travel Time	10.2 12 minutes	15.0 17 minutes	13.8 19 minutes	21.3 29 minutes
Cost per ton, per mile General rate	Cost per ton Trailer			
\$ N/A	\$ 466.38	\$ 466.38	\$ 466.38	\$ 512.50

**A SPECIAL NOTE FROM THE PURCHASING DIVISION**

*Bid results posted are before evaluation team review and award recommendation.*





## Biosolids Transportation Contract YEAR 3 BID FORM

**July 1, 2023 to June 30, 2024**

LANDFILL	Republic Citizens Grand Blanc	Brent Run Montrose	Venice Park Lennon	Waste Management Birch Run
LOCATION	2361 W Grand Blanc RD Grand Blanc MI 48439	8335 Vienna RD Montrose MI 48457	9536 E Lennon RD Lennon MI 48449	4143 East Rathbun RD Birch Run, MI 48415
DISTANCE, Miles Travel Time	10.2 12 minutes	15.0 17 minutes	13.8 19 minutes	21.3 29 minutes
Cost per ton, per mile General rate	<b>Cost per ton Trailer</b>			
\$ N/A	\$ 478.04	\$ 478.04	\$ 478.04	\$ 525.31

**A SPECIAL NOTE FROM THE PURCHASING DIVISION**

*Bid results posted are before evaluation team review and award recommendation.*



## Biosolids (Landfill) Disposal Contract

### BID FORM

**Bidder #2: Republic Services of Flint**  
**4101 Holiday Drive, Flint, MI 48507**

Landfill (Sludge Disposal) Hours of Operation		YEAR 1 7/1/21 to 6/30/22	YEAR 2 7/1/22 to 6/30/23	YEAR 3 7/1/23 to 6/30/24
		Total cost per ton	Total cost per ton	Total cost per ton
Monday thru Friday		\$ 19.00 per ton	\$ 20.00 per ton	\$ 21.00 per ton
Saturday		\$ 19.00 per ton	\$ 20.00 per ton	\$ 21.00 per ton
Holidays		\$ 30.00 per ton	\$ 32.00 per ton	\$ 33.00 per ton
<b>TOTAL COST</b> 13,000 Tons per fiscal year		\$ 247,000.00	\$ 260,000.00	\$ 273,000.00

**A SPECIAL NOTE FROM THE PURCHASING DIVISION**

*Bid results posted are before evaluation team review and award recommendation.*



**Biosolids Transportation Contract  
YEAR 1 BID FORM**

**July 1, 2021 to June 30, 2022**

<b>LANDFILL</b>	<b>Republic Citizens Grand Blanc</b>	<b>Brent Run Montrose</b>	<b>Venice Park Lennon</b>	<b>Waste Management Birch Run</b>
<b>LOCATION</b>	2361 W Grand Blanc RD Grand Blanc MI 48439	8335 Vienna RD Montrose MI 48457	9536 E Lennon RD Lennon MI 48449	4143 East Rathbun RD Birch Run, MI 48415
<b>DISTANCE, Miles Travel Time</b>	<b>10.2</b> 12 minutes	<b>15.0</b> 17 minutes	<b>13.8</b> 19 minutes	<b>21.3</b> 29 minutes
<b>Cost per ton, per mile General rate</b>	<b>Cost per ton Trailer</b>			
\$	\$475.00 per trailer load	\$	\$	\$

**Biosolids Transportation Contract  
YEAR 2 BID FORM**

**July 1, 2022 to June 30, 2023**

<b>LANDFILL</b>	<b>Republic Citizens Grand Blanc</b>	<b>Brent Run Montrose</b>	<b>Venice Park Lennon</b>	<b>Waste Management Birch Run</b>
<b>LOCATION</b>	2361 W Grand Blanc RD Grand Blanc MI 48439	8335 Vienna RD Montrose MI 48457	9536 E Lennon RD Lennon MI 48449	4143 East Rathbun RD Birch Run, MI 48415
<b>DISTANCE, Miles Travel Time</b>	<b>10.2</b> 12 minutes	<b>15.0</b> 17 minutes	<b>13.8</b> 19 minutes	<b>21.3</b> 29 minutes
<b>Cost per ton, per mile General rate</b>	<b>Cost per ton Trailer</b>			
\$	\$490.00 per trailer load	\$	\$	\$

**A SPECIAL NOTE FROM THE PURCHASING DIVISION**

*Bid results posted are before evaluation team review and award recommendation.*



## Biosolids Transportation Contract YEAR 3 BID FORM

**July 1, 2023 to June 30, 2024**

LANDFILL	Republic Citizens Grand Blanc	Brent Run Montrose	Venice Park Lennon	Waste Management Birch Run
LOCATION	2361 W Grand Blanc RD Grand Blanc MI 48439	8335 Vienna RD Montrose MI 48457	9536 E Lennon RD Lennon MI 48449	4143 East Rathbun RD Birch Run, MI 48415
DISTANCE, Miles Travel Time	<b>10.2</b> 12 minutes	<b>15.0</b> 17 minutes	<b>13.8</b> 19 minutes	<b>21.3</b> 29 minutes
Cost per ton, per mile General rate	<b>Cost per ton Trailer</b>			
\$	\$500.00 per trailer load	\$	\$	\$

**A SPECIAL NOTE FROM THE PURCHASING DIVISION**

*Bid results posted are before evaluation team review and award recommendation.*

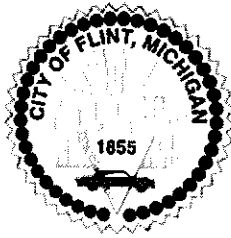

## Biosolids (Landfill) Disposal Contract

### BID FORM

**Bidder #3: Waste Management of Michigan, Inc.**  
**4143 East Rathbun Rd., Birch Run, MI 48415**

<b>Landfill (Sludge Disposal) Hours of Operation</b>		YEAR 1 7/1/21 to 6/30/22	YEAR 2 7/1/22 to 6/30/23	YEAR 3 7/1/23 to 6/30/24
		Total cost per ton	Total cost per ton	Total cost per ton
Monday thru Friday		\$ 38.50	\$ 40.40	\$ 42.43
Saturday		Closed	Closed	Closed
Holidays		Closed	Closed	Closed
<b>TOTAL COST 13,000 Tons per fiscal year</b>		<b>\$ 500,000.00</b>	<b>\$ 525,200.00</b>	<b>\$ 551,590.00</b>

**A SPECIAL NOTE FROM THE PURCHASING DIVISION**

*Bid results posted are before evaluation team review and award recommendation.*



**Biosolids Transportation Contract  
YEAR 1 BID FORM**

LANDFILL	Republic Citizens Grand Blanc	Brent Run Montrose	Venice Park Lennon	Waste Management Birch Run
LOCATION	2361 W Grand Blanc RD Grand Blanc MI 48439	8335 Vienna RD Montrose MI 48457	9536 E Lennon RD Lennon MI 48449	4143 East Rathbun RD Birch Run, MI 48415
DISTANCE, Miles Travel Time	10.2 12 minutes	15.0 17 minutes	13.8 19 minutes	21.3 29 minutes
Cost per ton, per mile General rate	Cost per ton			
\$	\$ No Bid	\$ No Bid	\$ No Bid	\$ No Bid

**Biosolids Transportation Contract  
YEAR 2 BID FORM**

**July 1, 2022 to Aug 30, 2022**

LANDFILL	Republic Citizens Grand Blanc	Brent Run Montrose	Venice Park Lennon	Waste Management Birch Run
LOCATION	2361 W Grand Blanc RD Grand Blanc MI 48439	8335 Vienna RD Montrose MI 48457	9536 E Lennon RD Lennon MI 48449	4143 East Rathbun RD Birch Run, MI 48415
DISTANCE, Miles Travel Time	10.2 12 minutes	15.0 17 minutes	13.8 19 minutes	21.3 29 minutes
Cost per ton, per mile General rate	Cost per ton			
\$	\$ No Bid	\$ No Bid	\$ No Bid	\$ No Bid

**A SPECIAL NOTE FROM THE PURCHASING DIVISION**

*Bid results posted are before evaluation team review and award recommendation.*



## Biosolids Transportation Contract YEAR 3 BID FORM

~~July 1, 2023 to June 30, 2024~~

LANDFILL	Republic Citizens Grand Blanc	Brent Run Montrose	Venice Park Lennon	Waste Management Birch Run
LOCATION	2361 W Grand Blanc RD Grand Blanc MI 48439	8335 Vienna RD Montrose MI 48457	9536 E Lennon RD Lennon MI 48449	4143 East Rathbun RD Birch Run, MI 48415
DISTANCE, Miles Travel Time	<b>10.2</b> 12 minutes	<b>15.0</b> 17 minutes	<b>13.8</b> 19 minutes	<b>21.3</b> 29 minutes
Cost per ton, per mile General rate	<b>Cost per ton</b>			
\$	\$ No Bid	\$ No Bid	\$ No Bid	\$ No Bid

**A SPECIAL NOTE FROM THE PURCHASING DIVISION**

*Bid results posted are before evaluation team review and award recommendation.*

**CITY OF FLINT PROPOSAL NO.21000605**

**Sewage Sludge Cake Disposal and Transport Services**

**THE FOLLOWING PAGES MUST BE COMPLETED AND INCLUDED WITH SUBMITTAL  
IN THE FOLLOWING ORDER.**

**Purchasing Checklist:**

- Cover Sheet
- Exhibit A – Bid Form Submittal
- Exhibit B – List of References
- Exhibit C – Certificate of Insurance
- Exhibit D - Non-Bidder's Response
- City of Flint, Michigan Affidavit



**BID SUBMITTAL FORM**

**EXHIBIT A**

**Biosolids (Landfill) Disposal Contract**

**BID FORM**

<b>BIDDER Name and Address</b>		DHT Transport 2695 W. Vassar Rd Reese, MI 48757		
<b>Landfill (Sludge Disposal) Hours of Operation</b>		<b>YEAR 1</b> 7/1/21 to 6/30/22	<b>YEAR 2</b> 7/1/22 to 6/30/23	<b>YEAR 3</b> 7/1/23 to 6/30/24
		<b>Total cost per ton</b>	<b>Total cost per ton</b>	<b>Total cost per ton</b>
Monday thru Friday		\$ No Bid	\$ No Bid	\$ No Bid
Saturday		\$ No Bid	\$ No Bid	\$ No Bid
Holidays		\$ No Bid	\$ No Bid	\$ No Bid
<b>TOTAL COST 13,000 Tons per fiscal year</b>		\$ No Bid	\$ No Bid	\$ No Bid

**Biosolids Transportation Contract  
YEAR 1 BID FORM**

July 1, 2021 to June 30, 2022

<b>BIDDER Name and Address</b>	DHT Transport 2695 W. Vassar Rd Reese, MI 48757			
<b>LANDFILL</b>	<b>Republic Citizens Grand Blanc</b>	<b>Brent Run Montrose</b>	<b>Venice Park Lennon</b>	<b>Waste Management Birch Run</b>
<b>LOCATION</b>	2361 W Grand Blanc RD Grand Blanc MI 48439	8335 Vienna RD Montrose MI 48457	9536 E Lennon RD Lennon MI 48449	4143 East Rathbun RD Birch Run MI 48415
<b>DISTANCE, Miles Travel Time</b>	<b>10.2</b> 12 minutes	<b>15.0</b> 17 minutes	<b>13.8</b> 19 minutes	<b>21.3</b> 29 minutes
<b>Cost per ton, per mile General rate</b>	<b>Cost per ton Trailer</b>			
\$ N/A	\$ 455.00	\$ 455.00	\$ 455.00	\$ 500.00

## Biosolids Transportation Contract YEAR 2 BID FORM

**July 1, 2022 to June 30, 2023**

<b>BIDDER Name and Address</b>	DHT Transport 2695 W. Vassar Rd Reese, MI 48757			
<b>LANDFILL</b>	<b>Republic Citizens Grand Blanc</b>	<b>Brent Run Montrose</b>	<b>Venice Park Lennon</b>	<b>Waste Management Birch Run</b>
<b>LOCATION</b>	2361 W Grand Blanc RD Grand Blanc MI 48439	8335 Vienna RD Montrose MI 48457	9536 E Lennon RD Lennon MI 48449	4143 East Rathbun RD Birch Run MI 48415
<b>DISTANCE, Miles Travel Time</b>	<b>10.2</b> 12 minutes	<b>15.0</b> 17 minutes	<b>13.8</b> 19 minutes	<b>21.3</b> 29 minutes
<b>Cost per ton, per mile General rate</b>	<b>Cost per ton Trailer</b>			
\$ N/A	\$ 466.38	\$ 466.38	\$ 466.38	\$ 512.50

## Biosolids Transportation Contract YEAR 3 BID FORM

July 1, 2023 to June 30, 2024

<b>BIDDER Name and Address</b>	DHT Transport 2695 W. Vassar Rd. Reese, MI 48757			
<b>LANDFILL</b>	<b>Republic Citizens Grand Blanc</b>	<b>Brent Run Montrose</b>	<b>Venice Park Lennon</b>	<b>Waste Management Birch Run</b>
<b>LOCATION</b>	2361 W Grand Blanc RD Grand Blanc MI 48439	8335 Vienna RD Montrose MI 48457	9536 E Lennon RD Lennon MI 48449	4143 East Rathbun RD Birch Run, MI 48415
<b>DISTANCE, Miles Travel Time</b>	<b>10.2</b> 12 minutes	<b>15.0</b> 17 minutes	<b>13.8</b> 19 minutes	<b>21.3</b> 29 minutes
<b>Cost per ton, per mile General rate</b>	<b>Cost per ton Trailer</b>			
\$ N/A	\$ 478.04	\$ 478.04	\$ 478.04	\$ 525.31

1. Failure to use this bid form shall result in bid disqualification.
2. Failure to bid on all items shall result in an "incomplete bid" determination.
3. List value-added considerations on a separate sheet of paper.

Terms: Net30

Fed. ID#: 47-4311495

Firm Name: DHT Transport

Address: 2695 W. Vassar Rd.

City/State/Zip Reese, MI 48757

Phone: 989-759-2010 Fax: 989-759-2019 Email: jzimmerman@dht-inc.com

Signed:  Date: 3/23/21



3/24/2021

City of Flint

Finance Department-Division of Purchases and Supplies

1101 S Saginaw St M203

Flint, MI 48502

RFP Title: Sewage Sludge Cake Disposal and Transport Services

RFP Num: 21000605

Deadline: 3/24/2021

Proposer: DHT Transport

To Whom it may Concern:

Scope of Work Changes have been made to the original proposal set forth by the City of Flint. DHT Transport requests the bid scope be changed from "per ton" to "per trailer". In this case "per trailer" refers to each unit being counted separately for purposes of billing. DHT Transport will continue to provide equipment capable of hauling the proposed 25 ton. Due to production at the plant, tonnage per trailer may vary. DHT Transport is attempting to level our cost and simplify billing. DHT Transport returns the landfill manifest each day to the plant for verification purposes.

**EXHIBIT B**

*Sewage Sludge Cake Disposal and Transport Services*

**LIST OF REFERENCES: (3) SIMILAR SCOPE OF WORK FROM THE LAST 5 YEARS**

Providing the following contact information enables the City of Flint to contact those accounts as references.

**Reference #1:**

Company/Municipality: City of Flint Water Pollution Control  
Contact Person: Don Lewis Title: Operations Supervisor  
Address: 4652 Beecher Rd  
City: Flint State: MI Zip: 48532  
Telephone: 810-282-5176 Fax: 810-732-7044  
Email: dlewis@cityofflint.com  
Type of Project: Sludge cake haul to landfill locations

Project Timeline (Dates): on going Budget: N/A

**Reference #2:**

Company/Municipality: Biotech  
Contact Person: Don Popma Title: General Manager  
Address: 1651 Beulah Hwy  
City: Beulah State: MI Zip: 49617  
Telephone: 231-882-7219 Fax: \_\_\_\_\_  
Email: dpopma@biotechag.com  
Type of Project: treated solid waste hauling to agricultural fields for disposal

Project Timeline (Dates): on going Budget: N/A

**EXHIBIT B**

*Sewage Sludge Cake Disposal and Transport Services*

**LIST OF REFERENCES: (3) SIMILAR SCOPE OF WORK FROM THE LAST 5 YEARS (continues)**

**Reference #3:**

Company/Municipality: Waste Management

Contact Person: Kevin Beste Title: Account Manager

Address: 48797 Alpha Dr, STE 150

City: Wixom State: MI Zip: 48393

Telephone: 248-640-8338

Fax: \_\_\_\_\_

Email: kbeste@wm.com

Type of Project: Sludge hauling and diverse environmental hauling projects

Project Timeline (Dates): on-going Budget: N/A

Client#: 60051

HAUBR

ACORD™

## CERTIFICATE OF LIABILITY INSURANCE

DATE (MM/DD/YYYY)  
2/22/2021

THIS CERTIFICATE IS ISSUED AS A MATTER OF INFORMATION ONLY AND CONFERS NO RIGHTS UPON THE CERTIFICATE HOLDER. THIS CERTIFICATE DOES NOT AFFIRMATIVELY OR NEGATIVELY AMEND, EXTEND OR ALTER THE COVERAGE AFFORDED BY THE POLICIES BELOW. THIS CERTIFICATE OF INSURANCE DOES NOT CONSTITUTE A CONTRACT BETWEEN THE ISSUING INSURER(S), AUTHORIZED REPRESENTATIVE OR PRODUCER, AND THE CERTIFICATE HOLDER.

**IMPORTANT:** If the certificate holder is an ADDITIONAL INSURED, the policy(ies) must be endorsed. If SUBROGATION IS WAIVED, subject to the terms and conditions of the policy, certain policies may require an endorsement. A statement on this certificate does not confer rights to the certificate holder in lieu of such endorsement(s).

PRODUCER Saginaw Bay Underwriters 1258 S. Washington P.O. Box 1928 Saginaw, MI 48605	CONTACT NAME:		
	PHONE (A/C, No, Ext): 989 752-8600	FAX (A/C, No):	
INSURED Hausbeck Brothers, Inc. DBA D.H.T. Logistics P.O. Box 375 Reese, MI 48757-0375	INSURER(S) AFFORDING COVERAGE		NAIC #
	INSURER A: Auto Owners Insurance Co.		18988
	INSURER B: Arch Specialty Insurance Co.		21199
	INSURER C: Federal Insurance Co.		002084
	INSURER D: Hartford Fire Insurance Co.		19682
INSURER E:			
INSURER F:			

COVERAGES CERTIFICATE NUMBER: REVISION NUMBER:

THIS IS TO CERTIFY THAT THE POLICIES OF INSURANCE LISTED BELOW HAVE BEEN ISSUED TO THE INSURED NAMED ABOVE FOR THE POLICY PERIOD INDICATED. NOTWITHSTANDING ANY REQUIREMENT, TERM OR CONDITION OF ANY CONTRACT OR OTHER DOCUMENT WITH RESPECT TO WHICH THIS CERTIFICATE MAY BE ISSUED OR MAY PERTAIN, THE INSURANCE AFFORDED BY THE POLICIES DESCRIBED HEREIN IS SUBJECT TO ALL THE TERMS, EXCLUSIONS AND CONDITIONS OF SUCH POLICIES. LIMITS SHOWN MAY HAVE BEEN REDUCED BY PAID CLAIMS.

INSR LTR	TYPE OF INSURANCE	ADOL INSR	WVO	POLICY NUMBER	POLICY EFF (MM/DD/YYYY)	POLICY EXP (MM/DD/YYYY)	LIMITS
A	GENERAL LIABILITY <input checked="" type="checkbox"/> COMMERCIAL GENERAL LIABILITY CLAIMS-MADE <input checked="" type="checkbox"/> OCCUR GENL AGGREGATE LIMIT APPLIES PER POLICY <input type="checkbox"/> PRO-JECT <input type="checkbox"/> LOC			1405217921	03/01/2021	03/01/2022	EACH OCCURRENCE \$1,000,000 DAMAGE TO RENTED PREMISES (Ea occurrence) \$50,000 MED EXP (Any one person) \$5,000 PERSONAL & ADV INJURY \$1,000,000 GENERAL AGGREGATE \$2,000,000 PRODUCTS - COMP/OP AGG \$2,000,000 \$
D	AUTOMOBILE LIABILITY <input checked="" type="checkbox"/> ANY AUTO ALL OWNED AUTOS SCHEDULED AUTOS HIRED AUTOS NON-OWNED AUTOS <input checked="" type="checkbox"/> Drive Other Car			83UENOH7010	03/01/2021	03/01/2022	COMBINED SINGLE LIMIT (Ea accident) \$2,000,000 BODILY INJURY (Per person) \$ BODILY INJURY (Per accident) \$ PROPERTY DAMAGE (Per accident) \$ \$ \$
A	<input checked="" type="checkbox"/> UMBRELLA LIAB <input checked="" type="checkbox"/> OCCUR EXCESS LIAB CLAIMS-MADE DEDUCTIBLE <input checked="" type="checkbox"/> RETENTION \$ 10000			4300942502	03/01/2021	03/01/2022	EACH OCCURRENCE \$6,000,000 AGGREGATE \$6,000,000 \$ \$
D	WORKERS COMPENSATION AND EMPLOYERS' LIABILITY ANY PROPRIETOR/PARTNER/EXECUTIVE OFFICER/EMBER EXCLUDED? (Mandatory in MI) if yes, describe under DESCRIPTION OF OPERATIONS below	Y/N N	N/A	83WEOH7009	03/01/2021	03/01/2022	<input checked="" type="checkbox"/> WC STATU-TORY LIMITS <input type="checkbox"/> OTH-ER E.L. EACH ACCIDENT \$1,000,000 E.L. DISEASE - EA EMPLOYEE \$1,000,000 E.L. DISEASE - POLICY LIMIT \$1,000,000
C	Motor Truck Cargo Reefer Coverage			06659684	03/01/2021	03/01/2022	\$400,000 Limit \$15,000 Deductible

DESCRIPTION OF OPERATIONS / LOCATIONS / VEHICLES (Attach ACORD 101, Additional Remarks Schedule, if more space is required)

Excess Umbrella (Auto Owners) #4300942502 goes over the General Liability.  
-Letter B: Excess Umbrella (Arch Specialty Insurance Co.) #UXP1027939-01 - Limits of \$3,000,000  
(See Attached Descriptions)

CERTIFICATE HOLDER City of Flint 1101 S Saginaw St Flint, MI 48501	CANCELLATION SHOULD ANY OF THE ABOVE DESCRIBED POLICIES BE CANCELLED BEFORE THE EXPIRATION DATE THEREOF, NOTICE WILL BE DELIVERED IN ACCORDANCE WITH THE POLICY PROVISIONS. AUTHORIZED REPRESENTATIVE 
---	---



## DESCRIPTIONS (Continued from Page 1)

each occurrence and \$3,000,000 aggregate - Policy Term 03/01/2021-03/01/2022 goes over the Automobile Policy, Workers Compensation and the Umbrella Policy (Auto Owners)

-Pollution Liability broad coverage for covered autos is included in the Automobile Policy form #CA9948.

-Form MCS-90 is included. Waiver of Subrogation does apply.

**\*\* Supplemental Name \*\***

Hausbeck Brothers, Inc. DBA D.H.T. Logistics

David Hausbeck

D.H.T. Specialized, LLC

D.H.T. Transport, LLC

D.H.T. Express, LLC

D.H.T. Agricultural Transport, LLC

City of Flint and including all elected and appointed officials, all employees and volunteers, all boards, commissions and/or authorities and their board members, employees and volunteers are included as additional insureds with respects to the general liability on a primary and non contributory basis and the auto liability. 30 Day notice of cancellation (10 Day Notice for nonpayment of premium) applies. (6/17)

**EXHIBIT D**

*Sewage Sludge Cake Disposal and Transport Services*  
**NON-BIDDER'S RESPONSE**

**VENDORS NAME:** \_\_\_\_\_

For the purpose of facilitating your firm's response to our invitation to bid, the City of Flint is interested in ascertaining reasons for prospective bidder's failure to respond to "Invitations to Bid". If your firm is not responding to this bid, please indicate the reason(s) by checking any appropriate item(s) below and return this form to the above address.

We are *not* responding to this "Invitation to Bid" for the following reason(s):

\_\_\_\_\_ Items or materials requested not manufactured by us or not available to our company.

\_\_\_\_\_ Our items and/or materials do not meet specifications.

\_\_\_\_\_ Specifications not clearly understood or applicable (too vague, too rigid, etc.).

\_\_\_\_\_ Quantities too Small.

\_\_\_\_\_ Insufficient time allowed for preparation of bid.

\_\_\_\_\_ Incorrect address used. Our correct mailing address is: \_\_\_\_\_

\_\_\_\_\_ Our branch / division handles this type of bid. We have forwarded this bid on to them but for the future the correct name and mailing address is: \_\_\_\_\_

\_\_\_\_\_ **OTHER:** \_\_\_\_\_

**Thank you for your participation in this bid.**

CITY OF FLINT, MICHIGAN AFFIDAVIT

AFFIDAVIT FOR INDIVIDUAL

STATE OF Michigan

S.S.

COUNTY OF Saginaw

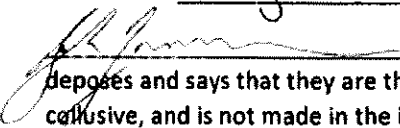

being duly sworn, deposes and says that they are the person making the above bid; and that said bid is genuine and not sham or collusive, and is not made in the interest of or on behalf of any person not therein named, and that they have not directly or indirectly induced or solicited any bidder to put in a sham bid; that they have not directly or indirectly induced or solicited any other person or corporation to refrain from bidding, and that they have not in any manner sought by collusion to secure themselves any advantage over other bidders.

Subscribed and sworn to before me at D.H.T. Transport, in said County and State,

this 24 day of March, A.D. 2021,

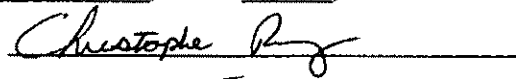

\*Notary Public, Tuscola County, Michigan

My Commission expires April 09, 2027

*NOTE: If executed outside of the State of Michigan, certificate by the Clerk of the Court of Record, authenticating the Notary's Signature and authority should be attached.*

FOR CORPORATION

STATE OF Michigan

S.S.

COUNTY OF Saginaw

Josh Zimmerman being duly sworn, deposes and says that she/he/they  
is General Manager of DHT Transport

(Official Title)

(Name of Corporation)

a corporation duly organized and doing business under the laws of the State of Michigan  
the corporation making the within and foregoing bid; that they executed said bid in behalf of said corporation by  
authority of its Board of Directors; that said bid is genuine and not sham or collusive and is not made in the  
interests of or on behalf of any person not herein named, and that they have not and said bidder has not directly  
or indirectly induced or solicited any other person or corporation to refrain from bidding; that they have not and  
said bidder has not in any manner sought by collusion to secure to themselves or to said corporation an advantage  
over other bidders.

Subscribed and sworn to before me at DHT Transport, in said County and State,  
this 24 day of March, A.D. 2021,

Christopher R. [Signature]

\*Notary Public, Tuscola County, Michigan

My Commission expires April 09, 2027

NOTE: If executed outside of the State of Michigan, certificate by the Clerk of the Court of Record, authenticating the Notary's Signature and authority should be attached.

**CITY OF FLINT PROPOSAL NO. 21000605**

**Sewage Sludge Cake Disposal and Transport Services**

**THE FOLLOWING PAGES MUST BE COMPLETED AND INCLUDED WITH SUBMITTAL  
IN THE FOLLOWING ORDER.**

**Purchasing Checklist:**

- Cover Sheet
- Exhibit A – Bid Form Submittal
- Exhibit B – List of References
- Exhibit C – Certificate of Insurance
- Exhibit D - Non-Bidder's Response
- City of Flint, Michigan Affidavit

**BID SUBMITTAL FORM**

**EXHIBIT A**

**Biosolids (Landfill) Disposal Contract**

**BID FORM**

<b>BIDDER Name and Address</b>	Republic Services of Flint 4101 Holiday Drive Flint, MI 48507		
<b>Landfill (Sludge Disposal) Hours of Operation</b>	<b>YEAR 1</b> 7/1/21 to 6/30/22	<b>YEAR 2</b> 7/1/22 to 6/30/23	<b>YEAR 3</b> 7/1/23 to 6/30/24
	<b>Total cost per ton</b>	<b>Total cost per ton</b>	<b>Total cost per ton</b>
Monday thru Friday	\$19.00 per ton \$	\$20.00 per ton \$	\$21.00 per ton \$
Saturday	\$19.00 per ton \$	\$20.00 per ton \$	\$21.00 per ton \$
Holidays	\$30.00 per ton \$	\$32.00 per ton \$	\$33.00 per ton \$
<b>TOTAL COST</b> <b>13,000 Tons per fiscal year</b>	\$247,000.00 \$	\$260,000.00 \$	\$273,000.00 \$

# Biosolids Transportation Contract

YEAR 1 BID FORM

July 1, 2021 to June 30, 2022

<b>BIDDER Name and Address</b>				
<b>LANDFILL</b>	<b>Republic Citizens Grand Blanc</b>	<b>Brent Run Montrose</b>	<b>Venice Park Lennon</b>	<b>Waste Management Birch Run</b>
<b>LOCATION</b>	2361 W Grand Blanc RD Grand Blanc MI 48439	8335 Vienna RD Montrose MI 48457	9536 E Lennon RD Lennon MI 48449	4143 East Rathbun RD Birch Run, MI 48415
<b>DISTANCE, Miles Travel Time</b>	<b>10.2</b> 12 minutes	<b>15.0</b> 17 minutes	<b>13.8</b> 19 minutes	<b>21.3</b> 29 minutes
<b>Cost per ton, per mile General rate</b>	<b>Cost per <del>ton</del> Trailer</b>			
\$	\$ <small>\$475.00 per trailer load</small>	\$	\$	\$

**Biosolids Transportation Contract  
YEAR 2 BID FORM**

**July 1, 2022 to June 30, 2023**

<b>BIDDER Name and Address</b>				
<b>LANDFILL</b>	<b>Republic Citizens Grand Blanc</b>	<b>Brent Run Montrose</b>	<b>Venice Park Lennon</b>	<b>Waste Management Birch Run</b>
<b>LOCATION</b>	2361 W Grand Blanc RD Grand Blanc MI 48439	8335 Vienna RD Montrose MI 48457	9536 E Lennon RD Lennon MI 48449	4143 East Rathbun RD Birch Run, MI 48415
<b>DISTANCE, Miles Travel Time</b>	<b>10.2</b> 12 minutes	<b>15.0</b> 17 minutes	<b>13.8</b> 19 minutes	<b>21.3</b> 29 minutes
<b>Cost per ton, per mile General rate</b>	<b>Cost per <del>ton</del> Trailer</b>			
\$	\$490.00 per trailer load	\$	\$	\$



## Biosolids Transportation Contract YEAR 3 BID FORM

July 1, 2023 to June 30, 2024

<b>BIDDER Name and Address</b>				
<b>LANDFILL</b>	<b>Republic Citizens Grand Blanc</b>	<b>Brent Run Montrose</b>	<b>Venice Park Lennon</b>	<b>Waste Management Birch Run</b>
<b>LOCATION</b>	2361 W Grand Blanc RD Grand Blanc MI 48439	8335 Vienna RD Montrose MI 48457	9536 E Lennon RD Lennon MI 48449	4143 East Rathbun RD Birch Run, MI 48415
<b>DISTANCE, Miles Travel Time</b>	<b>10.2</b> 12 minutes	<b>15.0</b> 17 minutes	<b>13.8</b> 19 minutes	<b>21.3</b> 29 minutes
<b>Cost per ton, per mile General rate</b>	<b>Cost per ton<sup>XXXX</sup> Trailer</b>			
\$	\$500.00 per trailer load	\$	\$	\$

1. Failure to use this bid form shall result in bid disqualification.
2. Failure to bid on all items shall result in an "incomplete bid" determination.
3. List value-added considerations on a separate sheet of paper.

Terms: Net 30 days Fed. ID#: 38 - 329 3469

Firm Name: Republic Services

Address: 4101 Holiday drive

City/State/Zip: Flint, MI 48507

Phone: 810/768/2222 Fax: \_\_\_\_\_ Email: Tjohnston@republicservices.com

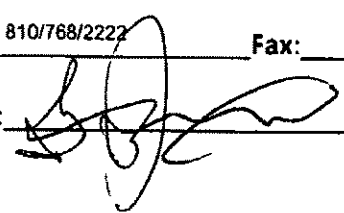
Signed:  Date: 03/24/2021

**EXHIBIT B**

*Sewage Sludge Cake Disposal and Transport Services*

**LIST OF REFERENCES: (3) SIMILAR SCOPE OF WORK FROM THE LAST 5 YEARS**

Providing the following contact information enables the City of Flint to contact those accounts as references.

**Reference #1:**

Company/Municipality: City of Bay City

Contact Person: Phil Smith Title: Director of Operations

Address: 2905 N Water Street

City: Bay City State: MI Zip: 48708

Telephone: (989) 893-5121 Fax: \_\_\_\_\_

Email: Psmith@baycitymi.org

Type of Project: Sludge filter cake hauling and disposal

Project Timeline (Dates): 07/01/18 through current Budget: \$150,000 annually

**Reference #2:**

Company/Municipality: Genoa Osceola Sewer and Water authority

Contact Person: Jim Aulette Title: Director

Address: 2911 Dorr Road

City: Brighton, State: MI Zip: 48116

Telephone: (517) 642-9653 Fax: \_\_\_\_\_

Email: jima@mhog.org

Type of Project: Sludge filter cake hauling and disposal

Project Timeline (Dates): 4-20-15 through present Budget: \$200,000 annually

**EXHIBIT B**

*Sewage Sludge Cake Disposal and Transport Services*

**LIST OF REFERENCES: (3) SIMILAR SCOPE OF WORK FROM THE LAST 5 YEARS (continues)**

**Reference #3:**

Company/Municipality: North Kent Sewer Authority

Contact Person: Scott Schoolcraft Title: Director

Address: 4775 Coit Ave N.E.

City: Grand Rapids State: MI Zip: 49525

Telephone: (616) 363-0702 Fax: \_\_\_\_\_

Email: jschoolcraft@nksa.us

Type of Project: Sludge filter cake hauling and disposal

Project Timeline (Dates): 1-01-2012 through present Budget: \$500,000 annually

## EXHIBIT C

### *Sewage Sludge Cake Disposal and Transport Services*

#### CERTIFICATE OF INSURANCE

##### INSURANCE REQUIREMENTS

The Contractor shall notify all insurance agents and companies retained by the Contractor that these insurance requirements shall be included in any Agreement between the Contractor and the City of Flint.

The Contractor shall purchase and maintain, at its sole expense and as long as it is providing services to the City, the following insurance coverage:

Commercial General Liability - Occurrence form, including coverage for bodily injury, personal injury, property damage (broad form), premises/operations, blanket contractual, and products/completed operations. Coverage shall be endorsed to include the City as an additional insured for work performed by the Contractor in accordance with the Agreement.

##### Minimum Limits:

- \$1,000,000 per occurrence/\$2,000,000 general aggregate
- \$2,000,000 aggregate for products and completed operations
- \$1,000,000 personal and advertising injury

Automobile - Michigan "no-fault" coverage, and residual automobile liability, comprehensive form, covering owned, hired, and non-owned automobiles. Coverage shall be endorsed to include the City as an additional insured for work performed by the Contractor in accordance with the Agreement.

##### Minimum Limits:

- No-fault coverages - statutory
- \$500,000 per person/\$1,000,000 per accident - bodily injury
- \$500,000 per occurrence - property damage
- A combined single limit of \$1,000,000 per occurrence

Workers' Compensation and Employer's Liability- Statutory coverage or proof acceptable to the City of approval as a self-insurer by the State of Michigan.

## EXHIBIT C

### *Sewage Sludge Cake Disposal and Transport Services* **CERTIFICATE OF INSURANCE (continues)**

#### Minimum Limits:

- Workers' Compensation - statutory
- Employer's Liability - \$100,000 each accident/\$100,000 disease - each employee
- \$500,000 disease - policy limit

Professional Liability – Covering acts, errors or omissions of a professional nature committed or alleged to have been committed by the Contractor or any of its subcontractors. Coverage shall be effective upon the date of the Agreement and shall remain effective for a period of three (3) years after the date of final payment thereunder. Such coverage shall be endorsed to include any subcontractors hired by the City.

#### Minimum Limits:

- \$1,000,000 per occurrence, \$1,000,000 annual aggregate

Insurance coverage shall cover all claims against the City of Flint, its officials and employees, arising out of the work performed by the Contractor or any subcontractors under the Agreement. Should any work be subcontracted, it shall be the responsibility of the Contractor to maintain Independent Contractor's Protective Liability Insurance with limits equal to those specified above for Commercial General Liability Insurance. In addition, the Contractor shall provide proof of Workers' Compensation Insurance for all subcontractors in compliance with the required statutory limits of the State of Michigan.

Said policies of insurance shall be with companies licensed to do business in the State of Michigan and in a form satisfactory to the City. All insurance companies must maintain a rating of B+, VIII or better from AM. Best Company. Certificates of insurance with a thirty-(30) day cancellation clause shall be filed with and approved by the City at least five (5) days in advance of commencing work under the Agreement. Cancellation, material restriction, non-renewal or lapse of any of the required policies shall be grounds for immediate termination of the Agreement by the City.

The City reserves the right to request a complete certified copy of the policies for the above coverage's.

Any reduction or exhaustion in the limits of required insurance coverage shall not be deemed to limit the indemnification afforded in accordance with the Agreement or any amendments thereto.

Depending on the subject matter of the transaction, the City may require other insurance coverage in addition to the coverage's contained herein.

**THE BID NUMBER IS TO APPEAR ON ALL INSURANCE CERTIFICATES**



# CERTIFICATE OF LIABILITY INSURANCE

Page 1 of 3

DATE (MM/DD/YYYY)  
06/30/2020

THIS CERTIFICATE IS ISSUED AS A MATTER OF INFORMATION ONLY AND CONFERS NO RIGHTS UPON THE CERTIFICATE HOLDER. THIS CERTIFICATE DOES NOT AFFIRMATIVELY OR NEGATIVELY AMEND, EXTEND OR ALTER THE COVERAGE AFFORDED BY THE POLICIES BELOW. THIS CERTIFICATE OF INSURANCE DOES NOT CONSTITUTE A CONTRACT BETWEEN THE ISSUING INSURER(S), AUTHORIZED REPRESENTATIVE OR PRODUCER, AND THE CERTIFICATE HOLDER.

**IMPORTANT: If the certificate holder is an ADDITIONAL INSURED, the policy(ies) must have ADDITIONAL INSURED provisions or be endorsed. If SUBROGATION IS WAIVED, subject to the terms and conditions of the policy, certain policies may require an endorsement. A statement on this certificate does not confer rights to the certificate holder in lieu of such endorsement(s).**

PRODUCER CANNON COCHRAN MANAGEMENT SERVICES, INC 17015 N. SCOTTSDALE RD SCOTTSDALE, AZ 85255	CONTACT NAME:	
	PHONE (A/C No.Ext):	FAX (A/C No.Ext):
E-MAIL ADDRESS: certifiaceteam@ccmsf.com		
INSURER(S) AFFORDING COVERAGE		NAIC #
INSURER A: ACE American Insurance Co.		22667
INSURER B: Indemnity Insurance Company of NA		43575
INSURER C: ACE Fire Underwriters		20702
INSURER D: Illinois Union Insurance Company		27960
INSURER E:		
INSURER F:		

INSURED  
REPUBLIC SERVICES, INC.  
18500 N. ALLIED WAY  
PHOENIX, AZ 85064

**COVERAGES**

CERTIFICATE NUMBER: 1755559

REVISION NUMBER:

THIS IS TO CERTIFY THAT THE POLICIES OF INSURANCE LISTED BELOW HAVE BEEN ISSUED TO THE INSURED NAMED ABOVE FOR THE POLICY PERIOD INDICATED. NOTWITHSTANDING ANY REQUIREMENT, TERM OR CONDITION OF ANY CONTRACT OR OTHER DOCUMENT WITH RESPECT TO WHICH THIS CERTIFICATE MAY BE ISSUED OR MAY PERTAIN, THE INSURANCE AFFORDED BY THE POLICIES DESCRIBED HEREIN IS SUBJECT TO ALL THE TERMS EXCLUSIONS AND CONDITIONS OF SUCH POLICIES. LIMITS SHOWN MAY HAVE BEEN REDUCED BY PAID CLAIMS.

NSR LTR	TYPE OF INSURANCE	ADDL INSD	SUBR WVD	POLICY NUMBER	POLICY EFF (MM/DD/YYYY)	POLICY EXP (MM/DD/YYYY)	LIMITS	
A	<input checked="" type="checkbox"/> COMMERCIAL GENERAL LIABILITY <input type="checkbox"/> CLAIMS-MADE <input checked="" type="checkbox"/> OCCUR  GEN'L AGGREGATE LIMIT APPLIES PER <input type="checkbox"/> POLICY <input type="checkbox"/> PROJECT <input type="checkbox"/> LOC <input type="checkbox"/> OTHER:			HDO G71450892	06/30/2020	06/30/2021	EACH OCCURRENCE	\$ 5,000,000
							DAMAGE TO RENTED PREMISES (Ea occurrence)	\$ 5,000,000
							MED EXP (Any one person)	
							PERSONAL & ADV INJURY	\$ 5,000,000
							GENERAL AGGREGATE	\$ 5,000,000
							PRODUCTS -COMP/OP AGG	\$ 5,000,000
A	<input checked="" type="checkbox"/> AUTOMOBILE LIABILITY <input checked="" type="checkbox"/> ANY AUTO <input checked="" type="checkbox"/> OWNED AUTOS ONLY <input checked="" type="checkbox"/> SCHEDULED AUTOS <input checked="" type="checkbox"/> HIRED AUTOS ONLY <input checked="" type="checkbox"/> NON-OWNED AUTOS ONLY  <input type="checkbox"/> UMBRELLA LIAB <input type="checkbox"/> OCCUR <input type="checkbox"/> EXCESS LIAB <input type="checkbox"/> CLAIMS-MADE <input type="checkbox"/> DED <input type="checkbox"/> RETENTION \$			ISA H25306425	06/30/2020	06/30/2021	COMBINED SINGLE LIMIT (Ea accident)	\$ 5,000,000
							BODILY INJURY (Per person)	
							BODILY INJURY (Per accident)	
							PROPERTY DAMAGE (Per accident)	
							EACH OCCURRENCE AGGREGATE	
B	<input checked="" type="checkbox"/> WORKERS COMPENSATION AND EMPLOYERS' LIABILITY <input type="checkbox"/> ANY PROPRIETOR/PARTNER/EXECUTIVE OFFICER/MEMBER EXCLUDED? (Mandatory in MI) <input type="checkbox"/> If yes, describe under DESCRIPTION OF OPERATIONS below	Y/N	N/A	WLR C67458424 AOS WLR C67458382 AZ/CAMA/OR SCF C67458461 - VM WCU C67458503 - OH XS TNS C66948560 - TX NSXS	06/30/2020 06/30/2020 06/30/2020 06/30/2020	06/30/2021 06/30/2021 06/30/2021 06/30/2021	<input checked="" type="checkbox"/> PER STATUTE <input type="checkbox"/> OTHER E.L. EACH ACCIDENT E.L. DISEASE -EA EMPLOYEE E.L. DISEASE -POLICY LIMIT	\$ 3,000,000 \$ 3,000,000 \$ 3,000,000

DESCRIPTION OF OPERATIONS / LOCATIONS / VEHICLES (ACORD 101, Additional Remarks Schedule, may be attached if more space is required)

Division Number: 3302 - Named Insured Includes: Tri-County Refuse Service, Inc. - Dba: Tri-County Refuse - Republic Waste Services of Mid Michigan - Republic Waste Services of Mid Michigan - White's Disposal - Republic Services of Upper Michigan - AW of Flint - Republic Services of Flint  
 Division Number: 4238 - Named Insured Includes: Citizens Disposal, Inc. - Dba: Citizens Disposal Landfill

**CERTIFICATE HOLDER****CANCELLATION**

City of Flint - Risk Management  
1101 S Saginaw Street  
Flint, MI 48502-1420  
United States

SHOULD ANY OF THE ABOVE DESCRIBED POLICIES BE CANCELLED BEFORE THE EXPIRATION DATE THEREOF, NOTICE WILL BE DELIVERED IN ACCORDANCE WITH THE POLICY PROVISIONS.

AUTHORIZED REPRESENTATIVE



# ADDITIONAL REMARKS SCHEDULE

AGENCY		NAMED INSURED	
POLICY NUMBER See First Page		REPUBLIC SERVICES, INC. 18500 N. ALLIED WAY PHOENIX, AZ 85054	
CARRIER See First Page	NAIC CODE	EFFECTIVE DATE:	
ADDITIONAL REMARKS		CERTIFICATE NUMBER: 1755559	

THIS ADDITIONAL REMARKS FORM IS A SCHEDULE TO ACORD FORM.  
 FORM NUMBER: 25 FORM TITLE: CERTIFICATE OF LIABILITY INSURANCE

The following provisions apply when required by written contract. As used below, the term certificate holder also includes any person or organization that the insured has become obligated to include as a result of an executed contract or agreement.

**GENERAL LIABILITY:**

Certificate holder is Additional Insured including on-going and completed operations when required by written contract.  
 Coverage is primary and non-contributory when required by written contract.  
 Waiver of Subrogation in favor of the certificate holder is included when required by written contract.

**AUTO LIABILITY:**

Certificate holder is Additional Insured when required by written contract.  
 Coverage is primary and non-contributory when required by written contract.  
 Waiver of Subrogation in favor of the certificate holder is included when required by written contract.

**WORKERS COMPENSATION AND EMPLOYERS LIABILITY:**

Waiver of Subrogation in favor of the certificate holder is included when required by written contract where allowed by state law.

Stop gap coverage for ND, WA and WY is covered under policy no. WLR C67458424 and stop gap coverage for OH is covered under policy no. WCU C67458503, as noted on page 1 of this certificate.

**TEXAS EXCESS INDEMNITY AND EMPLOYERS LIABILITY:**

Insured is a registered non-subscriber to the Texas Workers Compensation Act. Insured has filed an approved Indemnity Plan with the Texas Department of Insurance which offers an alternative in benefits to employees rather than the traditional Workers Compensation Insurance in Texas. The excess policy (#TNS C66948560) shown on this certificate provides excess Indemnity and Employers Liability coverage for the approved Indemnity Plan.

Contractual Liability is included in the General Liability and Automobile Liability coverage forms. The General Liability and Automobile Liability policies do not contain endorsements excluding Contractual Liability.

Separation of Insured (Cross Liability) coverage is provided to the Additional Insured, when required by written contract, per the Conditions of the Commercial General Liability Coverage form and the Automobile Liability Coverage form.

Additional Insured includes: City of Flint, all elected and appointed officials, all employees and volunteers, all boards, commissioners, and/or authorities and their board members, employees and volunteers, when required by written contract.

**NOTICE TO OTHERS ENDORSEMENT - NOTICE BY INSURED'S REPRESENTATIVE**

Named Insured Republic Services, Inc.			Endorsement Number 61
Policy Symbol HDO	Policy Number G71450892	Policy Period 06/30/2020 TO 06/30/2021	Effective Date of Endorsement
Issued By (Name of Insurance Company) ACE American Insurance Company			

**THIS ENDORSEMENT CHANGES THE POLICY. PLEASE READ IT CAREFULLY.**

**THIS ENDORSEMENT MODIFIES INSURANCE PROVIDED UNDER THE FOLLOWING:**

**COMMERCIAL GENERAL LIABILITY COVERAGE FORM**

- A. If we cancel, non-renew, or materially change the Policy prior to its expiration date by notice to the first Named Insured for any reason other than nonpayment of premium, we will, as set out in this endorsement, send written notice of such cancellation, non-renewal or material change, to the first Named Insured and will allow its representative to send such notice to all persons or organizations that the first Named Insured has contractually agreed to provide such notice.
- B. The notice referenced in this endorsement as provided by your representative is intended only to be a courtesy notification. The failure to provide advance notification of cancellation, non-renewal, or material change will impose no obligation or liability of any kind upon us, our agents or representatives, will not extend any Policy cancellation date and will not negate any cancellation, non-renewal or material change of the Policy.
- C. We will only be responsible for sending such notice to the first Named Insured who will notify its representative, and its representative will, in turn, send all applicable persons or organizations notice of cancellation, non-renewal, or material change at least 30 days prior to the applicable event date
- D. This endorsement does not apply in the event that the first Named Insured cancels the Policy.

All other terms and conditions of the Policy remain unchanged



**EXHIBIT D**

*Sewage Sludge Cake Disposal and Transport Services*  
**NON-BIDDER'S RESPONSE**

**VENDORS NAME:** \_\_\_\_\_

For the purpose of facilitating your firm's response to our invitation to bid, the City of Flint is interested in ascertaining reasons for prospective bidder's failure to respond to "Invitations to Bid". If your firm is not responding to this bid, please indicate the reason(s) by checking any appropriate item(s) below and return this form to the above address.

We are *not* responding to this "Invitation to Bid" for the following reason(s):

\_\_\_\_\_ Items or materials requested not manufactured by us or not available to our company.

\_\_\_\_\_ Our items and/or materials do not meet specifications.

\_\_\_\_\_ Specifications not clearly understood or applicable (too vague, too rigid, etc.).

\_\_\_\_\_ Quantities too Small.

\_\_\_\_\_ Insufficient time allowed for preparation of bid.

\_\_\_\_\_ Incorrect address used. Our correct mailing address is: \_\_\_\_\_

\_\_\_\_\_

Our branch / division handles this type of bid. We have forwarded this bid on to them but for the future the correct name and mailing address is: \_\_\_\_\_

\_\_\_\_\_ **OTHER:** \_\_\_\_\_

\_\_\_\_\_

**Thank you for your participation in this bid.**

FOR CORPORATION

STATE OF Michigan

S.S.

COUNTY OF Genesee

Metrel Demps Metrel Demps being duly sworn, deposes and says that she/he/they  
is General Manager of Tri County Refuse DBA (Republic Services of Flint)

(Official Title)

(Name of Corporation)

a corporation duly organized and doing business under the laws of the State of Deleware  
the corporation making the within and foregoing bid; that they executed said bid in behalf of said corporation by  
authority of its Board of Directors; that said bid is genuine and not sham or collusive and is not made in the  
interests of or on behalf of any person not herein named, and that they have not and said bidder has not directly  
or indirectly induced or solicited any other person or corporation to refrain from bidding; that they have not and  
said bidder has not in any manner sought by collusion to secure to themselves or to said corporation an advantage  
over other bidders.

Subscribed and sworn to before me at Republic Services, in said County and State,  
this 23 day of march, A.D. 2021

Lisa M Perry

\*Notary Public, Genesee County, Michigan





My Commission expires 9-12, 2023

NOTE: If executed outside of the State of Michigan, certificate by the Clerk of the Court of Record, authenticating the Notary's Signature and authority should be attached.

LISA M PERRY  
Notary Public - State of Michigan  
County of Genesee  
My Commission Expires Sep 12, 2023  
Acting in the County of Genesee

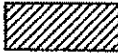
GRAND BLANC ROAD

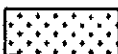
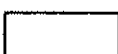
# ATTACHMENT "A"

-  CERTIFIED PARTIALLY CLOSED AREA = 14.40 AC.
-  ACTIVE FILL AREA NOT YET AT FINAL GRADE = 69.59 AC.
-  CONSTRUCTED AREA WITH FINANCIAL ASSURANCE = 0.0 AC.
-  UNCONSTRUCTED AREA WITH FINANCIAL ASSURANCE = 6.90 AC.
-  UNCONSTRUCTED AREA W/O FINANCIAL ASSURANCE = 18.10 AC.
-  ANCILLARY AREA = 127.52 AC.
-  EXISTING GROUNDWATER MONITORING WELLS
-  EXISTING GAS MONITORING PROBES

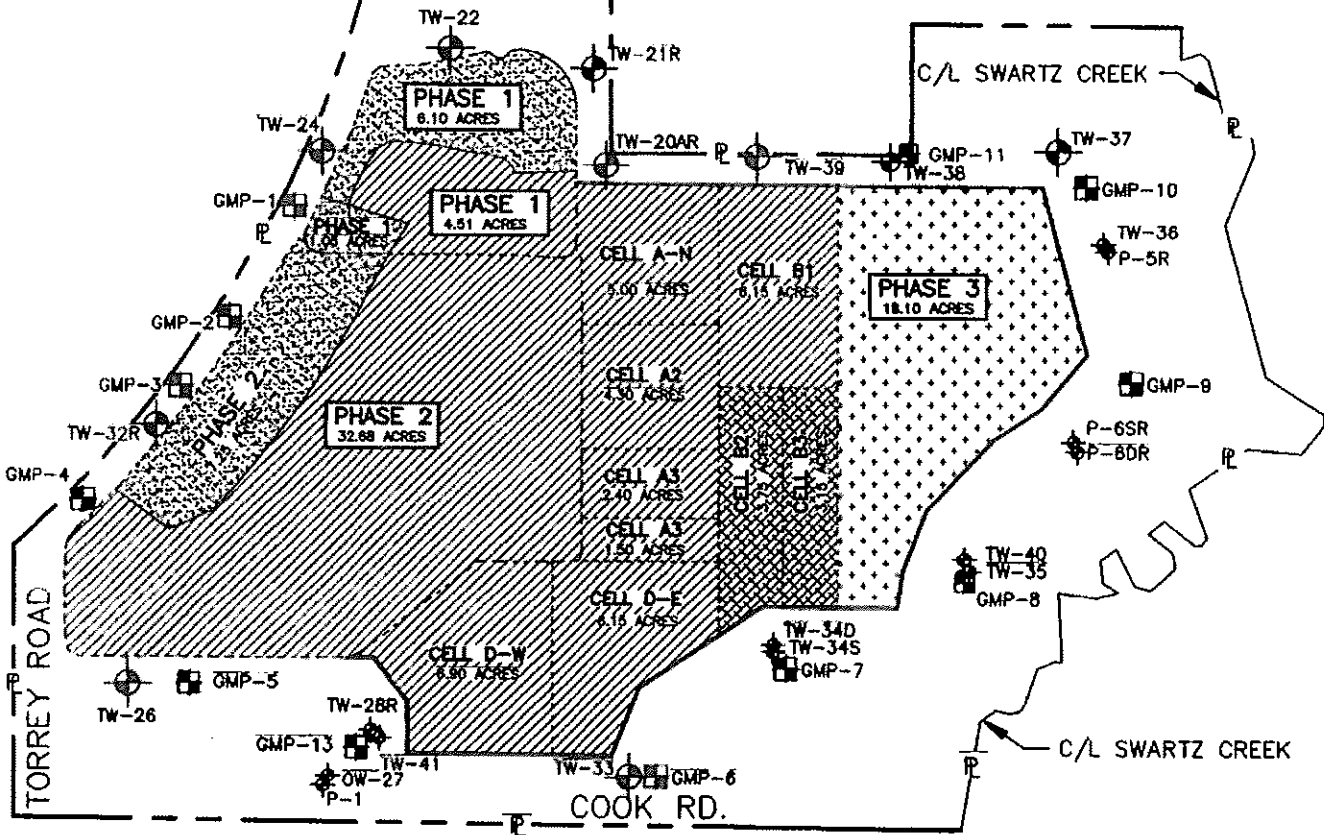

## MIDWESTERN CONSULTING



Civil, Environmental and  
Transportation Engineers  
Planners, Surveyors  
Landscape Architects

3815 Plaza Drive  
Ann Arbor, Michigan 48108  
Phone: 734.995.0200  
Fax 734.995.0599

## CITIZENS DISPOSAL, INC. ATTACHMENT "A"

DATE: 7/30/19      JOB NO.: **00022**

SCALE: 1" = 600'

 SHEET 1 OF 1



GRAND BLANC ROAD

- FACILITY PROPERTY = 313.7 AC.
- AREA SITED FOR USE = 236.5 AC.
- ▤ PERMITTED WASTE AREA = 109.0 AC.
- ▨ SOIL STOCKPILE/FUTURE EXPANSION

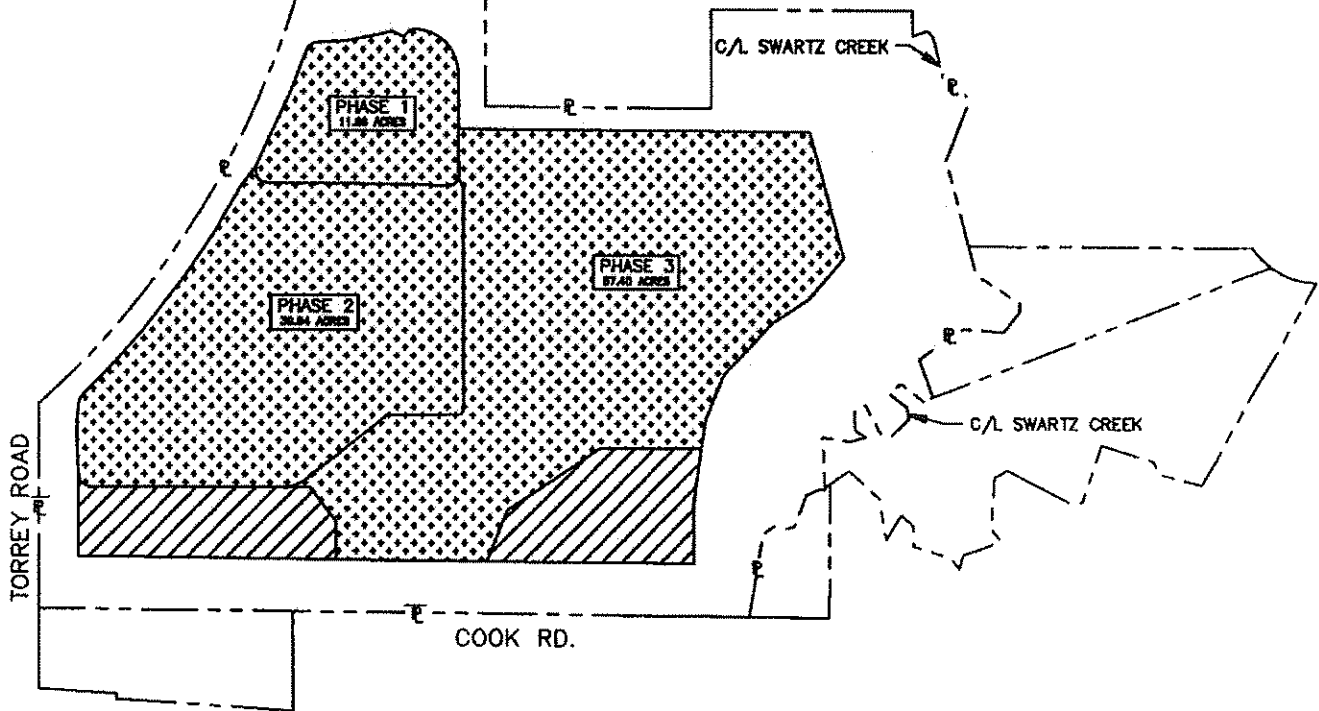

# MIDWESTERN CONSULTING



Civil, Environmental and  
Transportation Engineers  
Planners, Surveyors  
Landscape Architects

3815 Plaza Drive  
Ann Arbor, Michigan 48108  
Phone: 734.995.0200  
Fax 734.995.0599

CITIZENS DISPOSAL, INC.  
SITE PLAN

DATE: 6/28/12

JOB NO.: **00022**

SCALE: 1" = 800'



SHEET 1 OF 1



GRETCHEN WHITMER  
GOVERNOR

STATE OF MICHIGAN  
DEPARTMENT OF  
ENVIRONMENT, GREAT LAKES, AND ENERGY  
LANSING DISTRICT OFFICE



LIESL EICHLER CLARK  
DIRECTOR

July 16, 2020

Mr. Derek Neal  
Citizens Disposal, Inc.  
2361 West Grand Blanc Road  
Grand Blanc, Michigan 48439

Dear Mr. Neal:

SUBJECT: In Compliance, Citizens Disposal, Inc.  
Waste Data System Number 470517

On June 26, 2020, Department of Environment, Great Lakes, and Energy, Materials Management Division (MMD), staff conducted an inspection of Citizens Disposal Landfill, located at 2361 West Grand Blanc Road, Grand Blanc, Genesee County, Michigan, to evaluate compliance with Part 115, Solid Waste Management, of the Natural Resources and Environmental Protection Act, 1994 PA 451, as amended; the administrative rules promulgated pursuant to Part 115; and Citizens Disposal's Solid Waste Disposal Area Operating License Number 9530 issued on August 21, 2018. A copy of the completed inspection form is enclosed.

Based upon information obtained and observations made during the inspection, MMD staff has determined that Citizens Disposal is in compliance with the requirements of Part 115 that were evaluated.

If you have any questions, please feel free to contact me at the telephone number below or by e-mail at MaguireE@Michigan.gov.

Sincerely,

Evin P. Maguire  
Geologist  
Materials Management Division  
517-388-3525

Enclosure

**Michigan Department of Environmental Quality  
Waste Management and Radiological Protection Division  
Part 115 - Landfill Evaluation Report**

<b>Name of Facility</b> CITIZENS DISPOSAL INC		<b>Facility Number</b> 470517		<b>License # and Expiration Date</b> 9462      1/6/2021													
<b>Facility Address</b> 2361 W GRAND BLANC RD, GRAND BLANC, MI		<b>Facility Contact : Name -- Phone Number</b> ROBERT THORNTON      810-655-4207															
<b>LEGEND: (C) = Compliance (V) = Violation (NE) = Not Evaluated (*) = See Note (-) = Does not Apply</b>																	
<i>General Operations</i>			<i>Leachate / Stormwater Mangement</i>														
C	A.	Miscellaneous Operational Issues	C	J.	Surface Water Discharge												
C	B.	Blowing Debris, Dust, Odor & Vector Control	C	K.	Protection of Surface Waters												
C	C.	Gas Monitoring & Migration	C	L.	Leachate Control / Mangement												
No	D.	Are there any exceedances of the LEL?	C	M.	Leachate Volume / Head Records												
<i>Prohibited Waste Restrictions</i>			C	N.	Secondary Volume / ARF / RFR Records												
<table border="1" style="width: 100%; border-collapse: collapse;"> <tr> <td>C</td> <td>E.</td> <td>Hazardous Waste / Liquids / Yard Waste / Other Materials Prohibited for Disposal</td> </tr> <tr> <td>C</td> <td>F.</td> <td>Random / Suspicious Load Records</td> </tr> <tr> <td>C</td> <td>G.</td> <td>Load Inspection During Evaluation</td> </tr> <tr> <td>0</td> <td># of Loads Inspected</td> <td>0 yds. Volume of Loads</td> </tr> </table>			C	E.	Hazardous Waste / Liquids / Yard Waste / Other Materials Prohibited for Disposal	C	F.	Random / Suspicious Load Records	C	G.	Load Inspection During Evaluation	0	# of Loads Inspected	0 yds. Volume of Loads	<i>Daily / Interim / Final Cover</i>		
			C	E.	Hazardous Waste / Liquids / Yard Waste / Other Materials Prohibited for Disposal												
C	F.	Random / Suspicious Load Records															
C	G.	Load Inspection During Evaluation															
0	# of Loads Inspected	0 yds. Volume of Loads															
			C	O.	Adequacy of Daily Cover												
			Yes	P.	Are Alternate Daily Cover Materials Used?												
			Yes	Q.	Is the Use in Compliance with Approved Plan?												
			C	R.	Period and Adequacy of Interim Cover												
			Yes	S.	Are all lifts exposed for 90 days covered with Interim cover?												
<i>Permit and License Compliance</i>			C	T.	Completion of Area / Final Cover												
C	H.	Operations Conform to Permit, License, Order Conditions & Construction Certifications															
C	I.	Operations Conform to Approved Hydrogeo, Monitoring, Engineering and Operational Plans															
<b>REMARKS:</b>																	
Inspection was carried out onsite, but in separate vehicles via phone in order to comply with COVID-19 health guidelines Documents were not reviewed onsite, but electronically via email.																	
<b>Person Interviewed</b> Derek Neal		<b>Date of Inspection</b> 6/26/2020		<b>Time of Inspection</b> 2:00 PM													
<b>Inspected By</b> Evin Maguire		<b>Representing</b> EGLE-MMD															

**Michigan Department of Environmental Quality  
TYPE II LANDFILL OPERATING RECORD  
Evaluation Report**

**LEGEND: (C) = Compliance (V) = Violation (NE) = Not Evaluated ( \* ) = See Note (--) = Does not Apply**

C	A	Location Restriction Demonstrations	<b>REMARKS:</b>
C	B	Prohibited Waste Procedures	
C	C	Gas Monitoring Results	
C	D	Leachate, SCS Liquid and/or Gas Condensate Reintroduction Documentation	
C	E	LCS Monitoring Records	
C	F	SCS Monitoring Records	
C	G	Groundwater Monitoring Results	
C	H	Quantity of Waste Received	
C	I	Documentation of Placement of Interim Cover	
C	J	Closure Plans	
C	K	Post Closure Care Plans	
C	L	Groundwater Monitoring System Documentation	
C	M	Groundwater Sampling and Analysis Plan Documentation	
C	N	Statistical Procedures for Groundwater Monitoring	
C	O	Specific Procedures for Hydraulic Conductivity Testing for Cohesive Soils	
<b>REQUIRED BY</b>			
A	299.4438(1)(a)	B 299.4438(1)(b)	C 299.4438(1)(c)
D	299.4438(1)(d)	E 299.4438(1)(g) & 299.4432(2)	F 299.4438(1)(g) & 299.4432(4)
G	299.4438(1)(e)	H 299.4438(1)(f)	I 299.4438(1)(g) & 299.4429(7)
J	299.4438(1)(g)	K 299.4438(1)(g)	L 299.4438(1)(e)
M	299.4438(1)(e)	N 299.4438(1)(e)	O 299.4438(1)(g) & 299.4920(2)
<b>Name of Facility</b>		<b>Date of Inspection</b>	<b>Time of Inspection</b>
Citizens Disposal Landfill		9/24/19	1:00 pm
<b>Inspected By</b>		<b>Representing</b>	
Steve Blayer		MDEQ - RMD	

## OPERATING RECORD REQUIREMENTS

<b>A. Location Restriction Demonstrations for:</b>	<b>G. Ground Water Monitoring Results</b>
<input checked="" type="checkbox"/> Groundwater Isolation	<i>Downgradient &amp; Background Groundwater Quality</i>
<input checked="" type="checkbox"/> Horizontal Isolation	<input checked="" type="checkbox"/> i. Primary Indicators + pH (Rule 450)
<input checked="" type="checkbox"/> Sensitive Areas	<input checked="" type="checkbox"/> ii. Heavy Metals (Rule 452)
<input checked="" type="checkbox"/> Airports	<input checked="" type="checkbox"/> iii. Primary Volatile Organics (Rule 453)
<input checked="" type="checkbox"/> Floodplains	<input checked="" type="checkbox"/> iv. Secondary Organics (Rule 454)
<input checked="" type="checkbox"/> Wetlands	<input checked="" type="checkbox"/> Notice of Statistically Significant Change from Background
<input checked="" type="checkbox"/> Fault Areas and Seismic Impact Zones	<input checked="" type="checkbox"/> Assessment Monitoring Plan
<input checked="" type="checkbox"/> Unstable Areas	<input checked="" type="checkbox"/> i. Notice of Constituent Levels above Groundwater Protection Standards
<input checked="" type="checkbox"/> Vertical Expansion Exemption	<input checked="" type="checkbox"/> ii. Response Action Plan
<b>B. Prohibited Waste Procedures</b>	<input checked="" type="checkbox"/> iii. Assessment of Corrective Measures
<input checked="" type="checkbox"/> Random and Suspicious Load Inspection Records	<input checked="" type="checkbox"/> iv. Remedial Action Plan
<input checked="" type="checkbox"/> Training Procedures for Employees	<input checked="" type="checkbox"/> v. Notice of Implementation of Remedial Action Plan
<input checked="" type="checkbox"/> Notification Procedures for Hazardous Waste Discovery	
<b>C. Gas Monitoring Information</b>	<b>H. Records of the Quantity of Waste Received</b>
<input checked="" type="checkbox"/> Gas Monitoring Results	<input checked="" type="checkbox"/> (For Perpetual Care Fund)
<input checked="" type="checkbox"/> Notice of Exceedance	
<input checked="" type="checkbox"/> Remediation Plan (if Gas Levels Exceeded.)	<b>I. Documentation for the Placement of Interim Cover</b>
	<input checked="" type="checkbox"/> (Must be 1' Soil including Daily Cover or FML)
<b>D. Leachate, Secondary Collection System (SCS) Liquid and/or Gas Condensate Reintroduction Design Documentation</b>	
<input checked="" type="checkbox"/> (As required in Operating License)	<b>J. Closure Plans</b>
	An Engineering Plan in Compliance with Rule 446
	<input checked="" type="checkbox"/> [Until the Unit is Officially Certified Closed]
	<input checked="" type="checkbox"/> Notice of the Intent to Close a Unit
	<input checked="" type="checkbox"/> Approved Closure Certification
<b>E. Leachate Collection System (LCS) Monitoring Records</b>	
<input checked="" type="checkbox"/> Weekly Leachate Depths	<b>K. Post Closure Care Plan</b>
<input checked="" type="checkbox"/> Monthly Volume Pumped from each Unit	<input checked="" type="checkbox"/> An Engineering Plan in Compliance with Rule 447
<i>Leachate Quality</i>	<input checked="" type="checkbox"/> Approved Post Closure Certification
<input checked="" type="checkbox"/> i. Primary Inorganic Indicators (Rule 450)	
<input checked="" type="checkbox"/> ii. Primary Volatile Organics (Rule 453)	<b>L. Groundwater Monitoring System Documentation</b>
<input checked="" type="checkbox"/> iii. Other Constituents (Rules 451 & 452)	<input checked="" type="checkbox"/> Design Documentation
<input checked="" type="checkbox"/> LCS Pipe Cleanout and Inspection Data	<input checked="" type="checkbox"/> Installation Documentation
	<input checked="" type="checkbox"/> Development Documentation
<b>F. SCS Monitoring Records</b>	<input checked="" type="checkbox"/> Decommission Documentation
<input checked="" type="checkbox"/> Weekly Liquid Volumes Removed from each Unit	<input checked="" type="checkbox"/> Approval of Groundwater Monitoring System
Average Daily Flow Rate in gal/acre/day	
<input checked="" type="checkbox"/> [Calculated Weekly, Monthly, and Quarterly]	<b>M. Groundwater Sampling and Analysis Plan Documentation</b>
<i>SCS Liquid Quality</i>	<input checked="" type="checkbox"/> Sampling and Analysis Plan
<input checked="" type="checkbox"/> i. Primary Inorganic Indicators (Rule 450)	
<input checked="" type="checkbox"/> ii. Primary Volatile Organics (Rule 453)	<b>N. Statistical Procedures for Groundwater Monitoring</b>
<input checked="" type="checkbox"/> iii. Other Constituents (Rules 451 & 452)	<input checked="" type="checkbox"/> The Statistical Method for Groundwater Analysis
<input checked="" type="checkbox"/> SCS Pipe Cleanout and Inspection Data	<input checked="" type="checkbox"/> Justification if the Test is Different from Rule 908
	<b>O. Specific Procedures for Hydraulic Conductivity Testing</b>
	<input checked="" type="checkbox"/> The Specific Procedures for Testing Cohesive Soils



**CITY OF FLINT PROPOSAL NO. 21000605**

**Sewage Sludge Cake Disposal and Transport Services**

**THE FOLLOWING PAGES MUST BE COMPLETED AND INCLUDED WITH SUBMITTAL  
IN THE FOLLOWING ORDER.**

**Purchasing Checklist:**

- Cover Sheet
- Exhibit A – Bid Form Submittal
- Exhibit B – List of References
- Exhibit C – Certificate of Insurance
- Exhibit D - Non-Bidder's Response
- City of Flint, Michigan Affidavit



March 24, 2021

Joyce A. McClane  
City of Flint  
Finance Department-Purchases and Supplies  
1101 S Saginaw St., Room 203, 2<sup>nd</sup> Floor  
Flint, MI 48502

Re. Proposal # 21000605

Dear Ms. McClane:

Attached is Waste Management's proposal that we have prepared for City of Flint.

Based on a comprehensive evaluation of City of Flint's waste streams, service requirements and budgetary parameters, the proposed program contains solutions designed to strengthen City of Flint's operations, address compliance issues and enhance the overall business environment. It is designed to deliver those specific benefits you have identified as most important to City of Flint.

Waste Management appreciates the business relationship that we have had for several years as your current provider of this service. We are hopeful that we will be selected as the successful bidder in this new bid package. A completed Certificate of Insurance will be provided to the City with an award.

Waste Management would like to discuss the benefits of this proposal and other value-added synergies between our companies. We look forward to working with your team on this project and establishing a business relationship structured to meet your long-term goals.

We would like to discuss the details of our recommended service plan, obtain your feedback and discuss implementation procedures. In the meantime, please call me at 248 640 8338 if you have any questions.

Sincerely,

A handwritten signature in black ink, appearing to read 'Kevin Beste'.

Kevin Beste  
Industrial Account Manager  
Waste Management  
248 640 8338

**BID SUBMITTAL FORM**

**EXHIBIT A**

**Biosolids (Landfill) Disposal Contract**

**BID FORM**

<b>BIDDER Name and Address</b>		Waste Management of Michigan - People's Landfill 4143 Rathbun Rd Birch Run, MI 48415		
<b>Landfill (Sludge Disposal) Hours of Operation</b>		<b>YEAR 1</b> 7/1/21 to 6/30/22	<b>YEAR 2</b> 7/1/22 to 6/30/23	<b>YEAR 3</b> 7/1/23 to 6/30/24
		<b>Total cost per ton</b>	<b>Total cost per ton</b>	<b>Total cost per ton</b>
Monday thru Friday		\$ 38.50	\$ 40.40	\$ 42.43
Saturday		closed	closed	closed
Holidays		closed	closed	\$ closed
<b>TOTAL COST 13,000 Tons per fiscal year</b>		<b>\$ 500,000.00</b>	<b>\$ 525,200.00</b>	<b>\$ 551,590.00</b>

**Biosolids Transportation Contract**  
**YEAR 1 BID FORM**  
**July 1, 2021 to June 30, 2022**

<b>BIDDER Name and Address</b>	Waste Management of Michigan - People's Landfill 4143 Rathbun Rd Birch Run, MI 48415			
<b>LANDFILL</b>	<b>Republic Citizens Grand Blanc</b>	<b>Brent Run Montrose</b>	<b>Venice Park Lennon</b>	<b>Waste Management Birch Run</b>
<b>LOCATION</b>	2361 W Grand Blanc RD Grand Blanc MI 48439	8335 Vienna RD Montrose MI 48457	9536 E Lennon RD Lennon MI 48449	4143 East Rathbun RD Birch Run, MI 48415
<b>DISTANCE, Miles Travel Time</b>	<b>10.2</b> 12 minutes	<b>15.0</b> 17 minutes	<b>13.8</b> 19 minutes	<b>21.3</b> 29 minutes
<b>Cost per ton, per mile General rate</b>	<b>Cost per ton</b>			
\$	\$ no bid	\$ no bid	\$ no bid	\$ no bid

*Handwritten initials/signature*

## Biosolids Transportation Contract YEAR 2 BID FORM

July 1, 2022 to June 30, 2023

<b>BIDDER Name and Address</b>	Waste Management of Michigan People's Landfill 4143 Rathbun Rd Birch Run, MI 48415			
<b>LANDFILL</b>	<b>Republic Citizens Grand Blanc</b>	<b>Brent Run Montrose</b>	<b>Venice Park Lennon</b>	<b>Waste Management Birch Run</b>
<b>LOCATION</b>	2361 W Grand Blanc RD Grand Blanc MI 48439	8335 Vienna RD Montrose MI 48457	9536 E Lennon RD Lennon MI 48449	4143 East Rathbun RD Birch Run, MI 48415
<b>DISTANCE, Miles Travel Time</b>	<b>10.2</b> 12 minutes	<b>15.0</b> 17 minutes	<b>13.8</b> 19 minutes	<b>21.3</b> 29 minutes
<b>Cost per ton, per mile General rate</b>	<b>Cost per ton</b>			
\$	\$ no bid	\$ no bid	\$ no bid	\$ no bid

33

## Biosolids Transportation Contract YEAR 3 BID FORM

**July 1, 2023 to June 30, 2024**

<b>BIDDER Name and Address</b>	Waste Management of Michigan - People's Landfill 4143 Rathbun Rd Birch Run, MI 48415			
<b>LANDFILL</b>	<b>Republic Citizens Grand Blanc</b>	<b>Brent Run Montrose</b>	<b>Venice Park Lennon</b>	<b>Waste Management Birch Run</b>
<b>LOCATION</b>	2361 W Grand Blanc RD Grand Blanc MI 48439	8335 Vienna RD Montrose MI 48457	9536 E Lennon RD Lennon MI 48449	4143 East Rathbun RD Birch Run, MI 48415
<b>DISTANCE, Miles Travel Time</b>	<b>10.2</b> 12 minutes	<b>15.0</b> 17 minutes	<b>13.8</b> 19 minutes	<b>21.3</b> 29 minutes
<b>Cost per ton, per mile General rate</b>	<b>Cost per ton</b>			
\$	\$ no bid	\$ no bid	\$ no bid	\$ no bid

1. Failure to use this bid form shall result in bid disqualification.
2. Failure to bid on all items shall result in an "incomplete bid" determination.
3. List value-added considerations on a separate sheet of paper.

Terms: net 30 Fed. ID#: 28-1214786

Firm Name: Waste Management of Michigan, Inc.

Address: 4143 East Rathbun Rd

City/State/Zip Birch Run, MI 48415

Phone: 2486408338 Fax: n/a Email: kbeste@wm.com

Signed: \_\_\_\_\_ Date: March 23, 2021



FOR CORPORATION

STATE OF Michigan

S.S.

COUNTY OF Genesee

Kevin Beste being duly sworn, deposes and says that she/he/they  
is an Industrial Acct Mgr of Waste Management of Michigan, Inc.

(Official Title)

(Name of Corporation)

a corporation duly organized and doing business under the laws of the State of Michigan  
the corporation making the within and foregoing bid; that they executed said bid in behalf of said corporation by  
authority of its Board of Directors; that said bid is genuine and not sham or collusive and is not made in the  
interests of or on behalf of any person not herein named, and that they have not and said bidder has not directly  
or indirectly induced or solicited any other person or corporation to refrain from bidding; that they have not and  
said bidder has not in any manner sought by collusion to secure to themselves or to said corporation an advantage  
over other bidders.

Subscribed and sworn to before me at Flint, Michigan, in said County and State,

this 24th day of March, A.D. 20 21

Bethany Yerk

\*Notary Public, Genesee County, Michigan

My Commission expires March 8, 2023

NOTE: If executed outside of the State of Michigan, certificate by the Clerk of the Court of Record, authenticating the Notary's Signature and authority should be attached.

BETHANY YERK  
NOTARY PUBLIC - STATE OF MICHIGAN  
COUNTY OF LAPEER  
My Commission Expires March 8, 2023  
Acting in the County of Genesee

**CITY OF FLINT, MICHIGAN AFFIDAVIT**

**AFFIDAVIT FOR INDIVIDUAL**

STATE OF Michigan

S.S.

COUNTY OF Genesee

Kevin Beste being duly sworn, deposes and says that they are the person making the above bid; and that said bid is genuine and not sham or collusive, and is not made in the interest of or on behalf of any person not therein named, and that they have not directly or indirectly induced or solicited any bidder to put in a sham bid; that they have not directly or indirectly induced or solicited any other person or corporation to refrain from bidding, and that they have not in any manner sought by collusion to secure themselves any advantage over other bidders.

Subscribed and sworn to before me at Flint, Michigan, in said County and State,

this 24th day of March, A.D. 20 21

Beth Yerk

My Commission expires March 8, 2023

\*Notary Public, Genesee County, Michigan

*NOTE: If executed outside of the State of Michigan, certificate by the Clerk of the Court of Record, authenticating the Notary's Signature and authority should be attached.*

**BETHANY YERK**  
**NOTARY PUBLIC - STATE OF MICHIGAN**  
**COUNTY OF LAPEER**  
**My Commission Expires March 8, 2023**  
**Acting in the County of Genesee**



**EXHIBIT D**

*Sewage Sludge Cake Disposal and Transport Services*

**NON-BIDDER'S RESPONSE**

**VENDORS NAME:** \_\_\_\_\_

For the purpose of facilitating your firm's response to our invitation to bid, the City of Flint is interested in ascertaining reasons for prospective bidder's failure to respond to "Invitations to Bid". If your firm is not responding to this bid, please indicate the reason(s) by checking any appropriate item(s) below and return this form to the above address.

We are *not* responding to this "Invitation to Bid" for the following reason(s):

\_\_\_\_\_ Items or materials requested not manufactured by us or not available to our company.

\_\_\_\_\_ Our items and/or materials do not meet specifications.

\_\_\_\_\_ Specifications not clearly understood or applicable (too vague, too rigid, etc.).

\_\_\_\_\_ Quantities too Small.

\_\_\_\_\_ Insufficient time allowed for preparation of bid.

\_\_\_\_\_ Incorrect address used. Our correct mailing address is: \_\_\_\_\_

\_\_\_\_\_

\_\_\_\_\_ Our branch / division handles this type of bid. We have forwarded this bid on to them but for the future the correct name and mailing address is: \_\_\_\_\_

\_\_\_\_\_ **OTHER:** \_\_\_\_\_

\_\_\_\_\_

**Thank you for your participation in this bid.**

## **EXHIBIT C**

### *Sewage Sludge Cake Disposal and Transport Services*

## **CERTIFICATE OF INSURANCE**

### **INSURANCE REQUIREMENTS**

The Contractor shall notify all insurance agents and companies retained by the Contractor that these insurance requirements shall be included in any Agreement between the Contractor and the City of Flint.

The Contractor shall purchase and maintain, at its sole expense and as long as it is providing services to the City, the following insurance coverage:

**Commercial General Liability - Occurrence form, including coverage for bodily injury, personal injury, property damage (broad form), premises/operations, blanket contractual, and products/completed operations. Coverage shall be endorsed to include the City as an additional insured for work performed by the Contractor in accordance with the Agreement.**

#### **Minimum Limits:**

- **\$1,000,000 per occurrence/\$2,000,000 general aggregate**
- **\$2,000,000 aggregate for products and completed operations**
- **\$1,000,000 personal and advertising injury**

**Automobile - Michigan "no-fault" coverage, and residual automobile liability, comprehensive form, covering owned, hired, and non-owned automobiles. Coverage shall be endorsed to include the City as an additional insured for work performed by the Contractor in accordance with the Agreement.**

#### **Minimum Limits:**

- **No-fault coverages - statutory**
- **\$500,000 per person/\$1,000,000 per accident - bodily injury**
- **\$500,000 per occurrence - property damage**
- **A combined single limit of \$1,000,000 per occurrence**

**Workers' Compensation and Employer's Liability- Statutory coverage or proof acceptable to the City of approval as a self-insurer by the State of Michigan.**

## EXHIBIT C

### *Sewage Sludge Cake Disposal and Transport Services*

#### **CERTIFICATE OF INSURANCE (continues)**

##### Minimum Limits:

- Workers' Compensation - statutory
- Employer's Liability - \$100,000 each accident/\$100,000 disease - each employee
- \$500,000 disease - policy limit

Professional Liability – Covering acts, errors or omissions of a professional nature committed or alleged to have been committed by the Contractor or any of its subcontractors. Coverage shall be effective upon the date of the Agreement and shall remain effective for a period of three (3) years after the date of final payment thereunder. Such coverage shall be endorsed to include any subcontractors hired by the City.

##### Minimum Limits:

- \$1,000,000 per occurrence, \$1,000,000 annual aggregate

Insurance coverage shall cover all claims against the City of Flint, its officials and employees, arising out of the work performed by the Contractor or any subcontractors under the Agreement. Should any work be subcontracted, it shall be the responsibility of the Contractor to maintain Independent Contractor's Protective Liability Insurance with limits equal to those specified above for Commercial General Liability Insurance. In addition, the Contractor shall provide proof of Workers' Compensation Insurance for all subcontractors in compliance with the required statutory limits of the State of Michigan.

Said policies of insurance shall be with companies licensed to do business in the State of Michigan and in a form satisfactory to the City. All insurance companies must maintain a rating of B+, VIII or better from AM. Best Company. Certificates of insurance with a thirty-(30) day cancellation clause shall be filed with and approved by the City at least five (5) days in advance of commencing work under the Agreement. Cancellation, material restriction, non-renewal or lapse of any of the required policies shall be grounds for immediate termination of the Agreement by the City.

The City reserves the right to request a complete certified copy of the policies for the above coverage's.

Any reduction or exhaustion in the limits of required insurance coverage shall not be deemed to limit the indemnification afforded in accordance with the Agreement or any amendments thereto.

Depending on the subject matter of the transaction, the City may require other insurance coverage in addition to the coverage's contained herein.

**THE BID NUMBER IS TO APPEAR ON ALL INSURANCE CERTIFICATES**

**EXHIBIT B**

*Sewage Sludge Cake Disposal and Transport Services*

**LIST OF REFERENCES: (3) SIMILAR SCOPE OF WORK FROM THE LAST 5 YEARS**

Providing the following contact information enables the City of Flint to contact those accounts as references.

**Reference #1:**

Company/Municipality: City of Mount Clemens  
Contact Person: Jason Pich Title: Plant Superintendant  
Address: 1750 Clara St  
City: Mt CLEMens State: MI Zip: \_\_\_\_\_  
Telephone: 586 707 2979 Fax: \_\_\_\_\_  
Email: jpich@cityofmountclemens.com  
Type of Project: Bio Solids solidification and hauling  
\_\_\_\_\_  
Project Timeline (Dates): 3 years Budget: \$100,000

**Reference #2:**

Company/Municipality: City of Wyandotte  
Contact Person: Jason Tapp Title: Plant Manager  
Address: 797 Central  
City: Wyandotte State: MI Zip: 48192  
Telephone: 313-590-3509 Fax: \_\_\_\_\_  
Email: Jason.tapp@veolia.com  
Type of Project: sludge hauling  
\_\_\_\_\_  
Project Timeline (Dates): 5 years Budget: 1,000,000.00

**EXHIBIT B**

*Sewage Sludge Cake Disposal and Transport Services*

**LIST OF REFERENCES: (3) SIMILAR SCOPE OF WORK FROM THE LAST 5 YEARS (continues)**

**Reference #3:**

Company/Municipality: Bio Tech Agrnomics

Contact Person: Don Popma Title: General Manager

Address: \_\_\_\_\_

City: Beulah State: MI Zip: 49617

Telephone: 616.835.0100 Fax: \_\_\_\_\_

Email: dpopma@biotechag.com

Type of Project: bio solids management

Project Timeline (Dates): 5 years Budget: 2,000,000.00

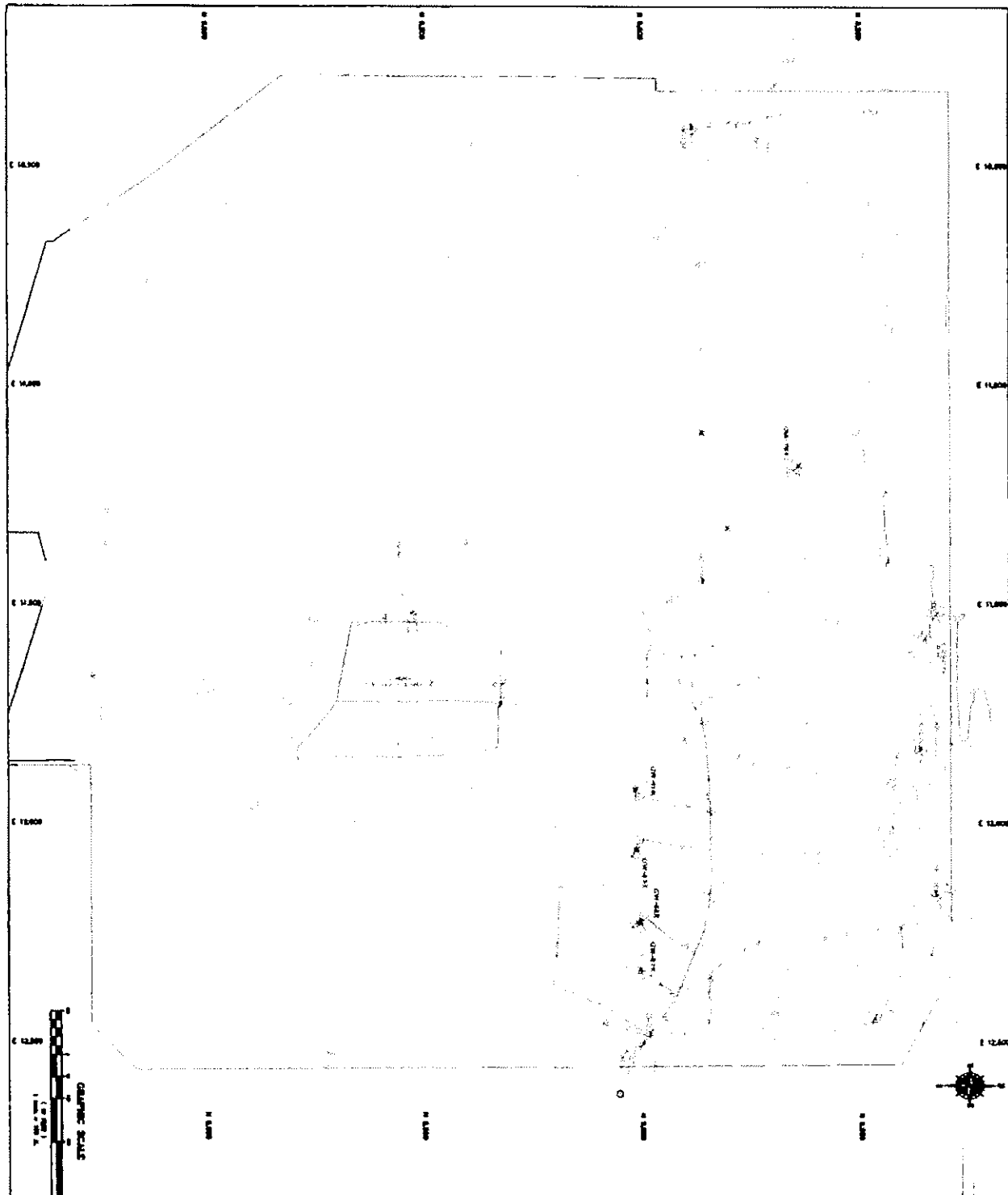

**RECORD DRAWING**

THIS DRAWING IS THE PROPERTY OF WATSON CONSULTANTS INC. AND IS NOT TO BE REPRODUCED OR TRANSMITTED IN ANY FORM OR BY ANY MEANS, ELECTRONIC OR MECHANICAL, INCLUDING PHOTOCOPYING, RECORDING, OR BY ANY INFORMATION STORAGE AND RETRIEVAL SYSTEM, WITHOUT THE WRITTEN PERMISSION OF WATSON CONSULTANTS INC.

NO.	DATE	DESCRIPTION	BY	CHKD.
1	11/15/00	ISSUED FOR PERMIT	WJ	WJ
2	11/15/00	ISSUED FOR PERMIT	WJ	WJ
3	11/15/00	ISSUED FOR PERMIT	WJ	WJ
4	11/15/00	ISSUED FOR PERMIT	WJ	WJ
5	11/15/00	ISSUED FOR PERMIT	WJ	WJ
6	11/15/00	ISSUED FOR PERMIT	WJ	WJ
7	11/15/00	ISSUED FOR PERMIT	WJ	WJ
8	11/15/00	ISSUED FOR PERMIT	WJ	WJ
9	11/15/00	ISSUED FOR PERMIT	WJ	WJ
10	11/15/00	ISSUED FOR PERMIT	WJ	WJ
11	11/15/00	ISSUED FOR PERMIT	WJ	WJ
12	11/15/00	ISSUED FOR PERMIT	WJ	WJ
13	11/15/00	ISSUED FOR PERMIT	WJ	WJ
14	11/15/00	ISSUED FOR PERMIT	WJ	WJ
15	11/15/00	ISSUED FOR PERMIT	WJ	WJ
16	11/15/00	ISSUED FOR PERMIT	WJ	WJ
17	11/15/00	ISSUED FOR PERMIT	WJ	WJ
18	11/15/00	ISSUED FOR PERMIT	WJ	WJ
19	11/15/00	ISSUED FOR PERMIT	WJ	WJ
20	11/15/00	ISSUED FOR PERMIT	WJ	WJ
21	11/15/00	ISSUED FOR PERMIT	WJ	WJ
22	11/15/00	ISSUED FOR PERMIT	WJ	WJ
23	11/15/00	ISSUED FOR PERMIT	WJ	WJ
24	11/15/00	ISSUED FOR PERMIT	WJ	WJ
25	11/15/00	ISSUED FOR PERMIT	WJ	WJ
26	11/15/00	ISSUED FOR PERMIT	WJ	WJ
27	11/15/00	ISSUED FOR PERMIT	WJ	WJ
28	11/15/00	ISSUED FOR PERMIT	WJ	WJ
29	11/15/00	ISSUED FOR PERMIT	WJ	WJ
30	11/15/00	ISSUED FOR PERMIT	WJ	WJ
31	11/15/00	ISSUED FOR PERMIT	WJ	WJ
32	11/15/00	ISSUED FOR PERMIT	WJ	WJ
33	11/15/00	ISSUED FOR PERMIT	WJ	WJ
34	11/15/00	ISSUED FOR PERMIT	WJ	WJ
35	11/15/00	ISSUED FOR PERMIT	WJ	WJ
36	11/15/00	ISSUED FOR PERMIT	WJ	WJ
37	11/15/00	ISSUED FOR PERMIT	WJ	WJ
38	11/15/00	ISSUED FOR PERMIT	WJ	WJ
39	11/15/00	ISSUED FOR PERMIT	WJ	WJ
40	11/15/00	ISSUED FOR PERMIT	WJ	WJ
41	11/15/00	ISSUED FOR PERMIT	WJ	WJ
42	11/15/00	ISSUED FOR PERMIT	WJ	WJ
43	11/15/00	ISSUED FOR PERMIT	WJ	WJ
44	11/15/00	ISSUED FOR PERMIT	WJ	WJ
45	11/15/00	ISSUED FOR PERMIT	WJ	WJ
46	11/15/00	ISSUED FOR PERMIT	WJ	WJ
47	11/15/00	ISSUED FOR PERMIT	WJ	WJ
48	11/15/00	ISSUED FOR PERMIT	WJ	WJ
49	11/15/00	ISSUED FOR PERMIT	WJ	WJ
50	11/15/00	ISSUED FOR PERMIT	WJ	WJ
51	11/15/00	ISSUED FOR PERMIT	WJ	WJ
52	11/15/00	ISSUED FOR PERMIT	WJ	WJ
53	11/15/00	ISSUED FOR PERMIT	WJ	WJ
54	11/15/00	ISSUED FOR PERMIT	WJ	WJ
55	11/15/00	ISSUED FOR PERMIT	WJ	WJ
56	11/15/00	ISSUED FOR PERMIT	WJ	WJ
57	11/15/00	ISSUED FOR PERMIT	WJ	WJ
58	11/15/00	ISSUED FOR PERMIT	WJ	WJ
59	11/15/00	ISSUED FOR PERMIT	WJ	WJ
60	11/15/00	ISSUED FOR PERMIT	WJ	WJ
61	11/15/00	ISSUED FOR PERMIT	WJ	WJ
62	11/15/00	ISSUED FOR PERMIT	WJ	WJ
63	11/15/00	ISSUED FOR PERMIT	WJ	WJ
64	11/15/00	ISSUED FOR PERMIT	WJ	WJ
65	11/15/00	ISSUED FOR PERMIT	WJ	WJ
66	11/15/00	ISSUED FOR PERMIT	WJ	WJ
67	11/15/00	ISSUED FOR PERMIT	WJ	WJ
68	11/15/00	ISSUED FOR PERMIT	WJ	WJ
69	11/15/00	ISSUED FOR PERMIT	WJ	WJ
70	11/15/00	ISSUED FOR PERMIT	WJ	WJ
71	11/15/00	ISSUED FOR PERMIT	WJ	WJ
72	11/15/00	ISSUED FOR PERMIT	WJ	WJ
73	11/15/00	ISSUED FOR PERMIT	WJ	WJ
74	11/15/00	ISSUED FOR PERMIT	WJ	WJ
75	11/15/00	ISSUED FOR PERMIT	WJ	WJ
76	11/15/00	ISSUED FOR PERMIT	WJ	WJ
77	11/15/00	ISSUED FOR PERMIT	WJ	WJ
78	11/15/00	ISSUED FOR PERMIT	WJ	WJ
79	11/15/00	ISSUED FOR PERMIT	WJ	WJ
80	11/15/00	ISSUED FOR PERMIT	WJ	WJ
81	11/15/00	ISSUED FOR PERMIT	WJ	WJ
82	11/15/00	ISSUED FOR PERMIT	WJ	WJ
83	11/15/00	ISSUED FOR PERMIT	WJ	WJ
84	11/15/00	ISSUED FOR PERMIT	WJ	WJ
85	11/15/00	ISSUED FOR PERMIT	WJ	WJ
86	11/15/00	ISSUED FOR PERMIT	WJ	WJ
87	11/15/00	ISSUED FOR PERMIT	WJ	WJ
88	11/15/00	ISSUED FOR PERMIT	WJ	WJ
89	11/15/00	ISSUED FOR PERMIT	WJ	WJ
90	11/15/00	ISSUED FOR PERMIT	WJ	WJ
91	11/15/00	ISSUED FOR PERMIT	WJ	WJ
92	11/15/00	ISSUED FOR PERMIT	WJ	WJ
93	11/15/00	ISSUED FOR PERMIT	WJ	WJ
94	11/15/00	ISSUED FOR PERMIT	WJ	WJ
95	11/15/00	ISSUED FOR PERMIT	WJ	WJ
96	11/15/00	ISSUED FOR PERMIT	WJ	WJ
97	11/15/00	ISSUED FOR PERMIT	WJ	WJ
98	11/15/00	ISSUED FOR PERMIT	WJ	WJ
99	11/15/00	ISSUED FOR PERMIT	WJ	WJ
100	11/15/00	ISSUED FOR PERMIT	WJ	WJ

**NOTES:**

1. ALL DIMENSIONS ARE IN FEET AND INCHES.
2. THE GAS SYSTEM SHALL BE INSTALLED IN ACCORDANCE WITH THE CITY OF WASHINGTON GAS CODE AND THE NATIONAL GAS PIPELINE CODE.
3. THE GAS SYSTEM SHALL BE INSTALLED IN ACCORDANCE WITH THE CITY OF WASHINGTON GAS CODE AND THE NATIONAL GAS PIPELINE CODE.
4. THE GAS SYSTEM SHALL BE INSTALLED IN ACCORDANCE WITH THE CITY OF WASHINGTON GAS CODE AND THE NATIONAL GAS PIPELINE CODE.
5. THE GAS SYSTEM SHALL BE INSTALLED IN ACCORDANCE WITH THE CITY OF WASHINGTON GAS CODE AND THE NATIONAL GAS PIPELINE CODE.
6. THE GAS SYSTEM SHALL BE INSTALLED IN ACCORDANCE WITH THE CITY OF WASHINGTON GAS CODE AND THE NATIONAL GAS PIPELINE CODE.
7. THE GAS SYSTEM SHALL BE INSTALLED IN ACCORDANCE WITH THE CITY OF WASHINGTON GAS CODE AND THE NATIONAL GAS PIPELINE CODE.
8. THE GAS SYSTEM SHALL BE INSTALLED IN ACCORDANCE WITH THE CITY OF WASHINGTON GAS CODE AND THE NATIONAL GAS PIPELINE CODE.
9. THE GAS SYSTEM SHALL BE INSTALLED IN ACCORDANCE WITH THE CITY OF WASHINGTON GAS CODE AND THE NATIONAL GAS PIPELINE CODE.
10. THE GAS SYSTEM SHALL BE INSTALLED IN ACCORDANCE WITH THE CITY OF WASHINGTON GAS CODE AND THE NATIONAL GAS PIPELINE CODE.

December 15, 2020

Terry Nichols  
Peoples Landfill, Inc.  
4143 E. Rathbun Road  
Birch Run, MI 48415

RE: Quarterly Inspection  
Peoples Garbage Disposal  
Facility #437908  
4143 E. Rathbun Road  
Taymouth Township  
Saginaw County, Michigan

Dear Mr. Nichols:

On December 11, 2020, this writer representing the Saginaw County Health Department conducted a quarterly inspection at the above captioned location. The purpose of the inspection was to evaluate compliance of the facility with the requirements of Part 115 of the Natural Resources and Environmental Protection Act P.A. 451 of 1994, as amended, and the rules promulgated pursuant to Part 115

At the time of the inspection, no operational violations were noted. Enclosed is a copy of the inspection report for your records.

Should you have any questions, please feel free to contact this office at (989) 758-3685.

Sincerely,

For Christina A. Harrington, M.P.H.  
Health Office

Jerry Maxson, R.E.H.S.  
Environmental Health Specialist I

JWM:afh

Enclosure

c: Lori Babcock, EGLE - MMD  
Saginaw County Planning Department  
Taymouth Township Supervisor

**Michigan Department of Environmental Quality  
Waste Management and Radiological Protection Division  
Part 115 - Landfill Evaluation Report**

<b>Name of Facility</b> People's Landfill, Inc.		<b>Facility Number</b> 437908		<b>License # and Expiration Date</b> 9480      7/28/2021	
<b>Facility Address</b> 4143 E. Rathbun Rd.		<b>Facility Contact : Name - Phone Number</b> Mr. Terry Nichols      (989) 777-1145			
<b>LEGEND: (C) = Compliance (V) = Violation (NE) = Not Evaluated (*) = See Note (-) = Does not Apply</b>					
<b>General Operations</b>			<b>Leachate / Stormwater Mangement</b>		
C	A.	Miscellaneous Operational Issues	C	J.	Surface Water Discharge
C	B.	Blowing Debris, Dust, Odor & Vector Control	C	K.	Protection of Surface Waters
C	C.	Gas Monitoring & Migration	C	L.	Leachate Control / Mangement
No	D.	Are there any exceedances of the LEL?	C	M.	Leachate Volume / Head Records
<b>Prohibited Waste Restrictions</b>			-	N.	Secondary Volume / ARF / RFR Records
			<b>Daily / Interim / Final Cover</b>		
C	E.	Hazardous Waste / Liquids / Yard Waste / Other Materials Prohibited for Disposal	C	O.	Adequacy of Daily Cover
C	F.	Random / Suspicious Load Records	No	P.	Are Alternate Daily Cover Materials Used?
NE	G.	Load Inspection During Evaluation		Q.	Is the Use in Compliance with Approved Plan?
# of Loads Inspected		yds. Volume of Loads	C	R.	Period and Adequacy of Interim Cover
<b>Permit and License Compliance</b>			Yes	S.	Are all lifts exposed for 90 days covered with interim cover?
C	H.	Operations Conform to Permit, License, Order Conditions & Construction Certifications	C	T.	Completion of Area / Final Cover
C	I.	Operations Conform to Approved Hydrogeo, Monitoring, Engineering and Operational Plans			
<b>REMARKS:</b>					
<b>Person Interviewed</b> Terry Nichols		<b>Date of Inspection</b> 12/11/2020		<b>Time of Inspection</b> 2:50 p.m.	
<b>Inspected By</b> Jerry Maxson		<b>Representing</b> EGLE - MMD			

DEFINITIONS





PROPOSAL# 22000030

RESOLUTION NO.: 210265

PRESENTED: JUN - 6 2021

ADOPTED: \_\_\_\_\_

BY THE CITY ADMINISTRATOR:

**RESOLUTION TO DUPERON CORPORATION  
FOR EAST PUMPING STATION WASHER COMPACTOR**

WHEREAS, in municipal wastewater treatment facilities, wastewater screening equipment is crucial to plant performance and for managing costs. The washer compactor dewateres and compacts the collected debris reducing odor and volume which in turn reduces operating and maintenance costs. Water Pollution Control (WPC) request to replace the current compactor at the Easting Pumping Station, which has failed and is not operable. WPC recommends the sole qualified bidder, Duperon Corporation, be awarded the bid in FY2022 for the amount of \$81,365 for the East Pump Station Washer Compactor.

Account Number	Account Name	Amount
590-550.300-977.000	Equipment	\$81,365.00
	<b>FY2022 GRAND TOTAL</b>	<b>\$81,365.00</b>

IT IS RESOLVED, that the appropriate City Officials are authorized to do all things necessary to enter into a contract with Duperon Corporation to provide the East Pump Station washer compactor for FY2022, pending budget adoption, for the amount of \$81,365.00.

APPROVED AS TO FORM:

Angela Wheeler  
Angela Wheeler (May 24, 2021 09:13 EDT)  
Angela Wheeler, Chief Legal Officer

APPROVED AS TO FINANCE:

shelbi frayer  
shelbi frayer (May 24, 2021 11:13 EDT)  
Shelbi Frayer, Chief Financial Officer

FOR THE CITY OF FLINT:

Clyde D Edwards  
Clyde D Edwards (May 24, 2021 14:45 EDT)  
Clyde Edwards, City Administrator

APPROVED BY CITY COUNCIL:

\_\_\_\_\_  
Kate Fields, City Council President

APPROVED AS TO PURCHASING:

Jennifer Ryan  
Jennifer Ryan (May 21, 2021 15:43 EDT)  
Jenn Ryan, Deputy Finance Director



# CITY OF FLINT

## RESOLUTION STAFF REVIEW FORM

**TODAY'S DATE:** 05/19/2021

**BID/PROPOSAL#** B22-030

**AGENDA ITEM TITLE:** East Pumping Station Washer Compactor

**PREPARED BY** John Florshinger  
Utilities Maintenance & SCADA Supervisor

**VENDOR NAME:** Duperon Corporation

**BACKGROUND/SUMMARY OF PROPOSED ACTION:**

In municipal wastewater treatment facilities, wastewater screening equipment is crucial to plant performance and for managing costs. The washer compactor dewateres and compacts the collected debris reducing odor and volume which in turn reduces operating and maintenance costs. This request to replace the current compactor at WPC's East Pumping Station which has failed and is not operable.

I recommend that the sole qualified bidder, Duperon Corporation, be awarded the bid in the FY 2022 budgeted amount of \$81,365.00 for the East Pump Station Washer Compactor.

**FINANCIAL IMPLICATIONS:** None

**BUDGETED EXPENDITURE?** YES  NO  IF NO, PLEASE EXPLAIN:

Dept.	Name of Account	Account Number	Grant Code	Amount
DPW-WPC	Equipment	590-550.300-977.000		\$81,365.00
<b>FY21 GRAND TOTAL</b>				<b>\$81,365.00</b>

**PRE-ENCUMBERED?** YES  NO  **REQUISITION NO:** 210004477

**ACCOUNTING APPROVAL:** \_\_\_\_\_ **Date:** \_\_\_\_\_

**WILL YOUR DEPARTMENT NEED A CONTRACT?** YES  NO   
*(If yes, please indicate how many years for the contract)* YEARS



## CITY OF FLINT

---

**WHEN APPLICABLE, IF MORE THAN ONE (1) YEAR, PLEASE ESTIMATE TOTAL AMOUNT FOR EACH BUDGET YEAR: (This will depend on the term of the bid proposal)**

**BUDGET YEAR 1**

**BUDGET YEAR 2**

**BUDGET YEAR 3**

**OTHER IMPLICATIONS (i.e., collective bargaining):** None.

**STAFF RECOMMENDATION: (PLEASE SELECT):**  **APPROVED**  **NOT APPROVED**

**DEPARTMENT HEAD SIGNATURE:**

  
(Jeanette Best, WPC Manager)



Sheldon A. Neeley

# City of Flint

## Department of Finance

### Division of Purchases & Supplies

---

May 18, 2021

**TO:** Jeanette Best  
**FROM:** Jennifer Ryan  
Deputy Finance Director  
**SUBJECT:** SEALED BIDS

Attached is one (1) bid that was received for **BID# 22000030 – EAST PUMPING STATION WASHER COMPACTOR**. Enclosed are copies for your file. **Bid Due Date: 5/18/21. Enclosed is a spreadsheet.**

Your staff review and recommendation form is needed as soon as possible. **Please use the new fillable form.** This form is to be used for your staff review.

A staff review must be completed for ALL **Bids/Proposals**. Please let me know if you need a copy of the fillable form.

**Please note:** If your project is being funded by any grants issued by the federal government, you must go to:  
<https://www.dol.gov/ofccp/regs/compliance/preaward/debarlist.htm> to ensure that the selected vendor has not been debarred.

**PLEASE NOTE:**

Results may be viewed next business day online **EXCEPT** when a bid is under review. The bidders/public will only see the names of the bidders that submitted a bid, not their cost. This will protect the bidders cost in case there is a re-bid.

**If you have any questions, please feel free to give me a call or send an email.**

  
\_\_\_\_\_  
Signature

cc: Shelbi Frayer

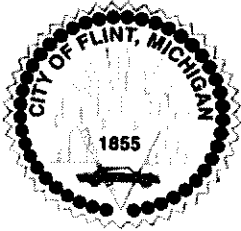

# City of Flint

## Department of Finance Division of Purchases & Supplies

---

Sheldon A. Neeley

Today's Date:

Please complete the following form if you decide to rebid:

**Proposal #**

**DETAILED REASON FOR WANTING TO REBID:**

**Authorized Signature and Title:**

**Date Signed**

.....  
**PURCHASING USE ONLY**

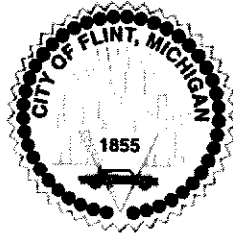

**SEALED PROPOSALS RECEIVED IN THE DIVISION OF PURCHASES & SUPPLIES**  
**For East Pumping Station Washer Compactor**  
**BID# 22000030**  
 Approximate Annual Quantities – Not Guaranteed  
 Furnish as requested for the period 7/1/21 – 6/30/22

**Bidder# 1: Duperon Corporation**  
**Saginaw, MI**

Description	Unit	QTY	Amount
Washer Compactor including hopper and discharge chute for East Pumping Stations.	LOT	1	<b>\$81,365.00</b>
<b>TOTAL</b>			<b>\$81,365.00</b>

**A SPECIAL NOTE FROM THE PURCHASING DIVISION**

*Bid results posted are before evaluation team review and award recommendation.*



May 17, 2021

Joyce A. McClane  
Division of Purchase and Supplies  
1101 S. Saginaw St.; Room 203  
Flint, Michigan 48502

RE: East Pumping Station Washer Compactor  
    BID #22000030  
    Duperon Proposal # 9450

Dear Ms. McClane;

Thank you for the opportunity to provide the Duperon washer compactor equipment for the City of Flint – East Pumping Station project. Duperon Corporation is the leader in preliminary liquids/solids separation technologies and provides technologies for coarse screening, fine screening, low flow screening, ultra screening, washing compacting and conveying. Duperon® technologies are designed and manufactured in Saginaw, Michigan and operate in North America and internationally. Saginaw is less than an hour from the East Pumping Station and all of our engineering, manufacturing after sale service and spare parts are located close by.

Privately owned, Duperon Corporation was established in 1985. Terry Duperon's knowledge and experience of pumps and pumping, as well as understanding the problems caused by water-borne debris led him to invent the Duperon® Self-Cleaning Trashrack. This technology is now a favorite for tough storm water and flood control applications in North America and as far away as New Zealand.

In 1995, Terry developed the FlexLink™ and created the patented Duperon® FlexRake®, which is now used in more than 1,500 installations in municipal wastewater, industrial wastewater and open channel applications throughout the world. This important screening technology has eliminated the need for confined space entries by engineering out submerged bearings and sprockets and has dramatically reduced maintenance for screen applications. Duperon developed the washer compactor in 2003 and it is unique as it has two interleaving augers that help to wash and move the debris to the storage bin up to forty feet away.

This proposal follows the sections laid out in the RFP and lists the details of our equipment and how our compactor would perform at the East Pump Station.

We look forward to working with you further on this project. Please visit our website at [www.Duperon.com](http://www.Duperon.com) to learn more about our company, innovative products and successful projects

Respectfully,

David Herald  
Lead Sales Project Manager  
Duperon Corporation, LLC

**BID NO. 22000030**  
**EAST PUMPING STATION WASHER COMPACTOR**

**THE FOLLOWING PAGES MUST BE COMPLETED AND INCLUDED WITH SUBMITTAL IN THE FOLLOWING ORDER.**

**Purchasing Checklist:**

- Cover Sheet
- Exhibit A - Complete Proposal Submittal with detailed Summary of Pricing
- Exhibit B –Qualifications and Licenses Requirements
- Exhibit C – Disclosure of Supplier Responsibility Statement
- Exhibit D - List of References
- Exhibit E - Certificate of Insurance
- Exhibit F – Non-Bidder’s Response
- City of Flint, Michigan Affidavit



## ❖ EXHIBIT A - SUBMITTAL WITH DETAILED SUMMARY OF PRICING

**BID NO. 22000030  
EAST PUMPING STATION WASHER COMPACTOR****SCOPE OF SERVICES**

The City of Flint Water Pollution Control (herein referred to as WPC) is seeking qualified washer compactor manufacturers to supply a new compactor for its East Pumping Station. This bid shall include all necessary engineering, integration, consultation, recommendations and oversight required to provide a complete and functioning compaction equipment. WPC shall have the final decision on all equipment, design, engineering, programming and recommendations

**1.1 SUMMARY****A. SCOPE OF WORK**

Manufacturer shall supply an interleaving, dual auger washer compactor assembly as detailed in the following specifications. A single unit shall provide washing and compacting action on wastewater screenings collected from two (2) existing Duperon barscreens located at the City's East Pumping Station.

**B. QUALITY ASSURANCE**

- 1 All equipment supplied under this section shall be of a single manufacturer and demonstrate, to the satisfaction of the City, that the quality is equal to equipment made by those manufacturers specifically named herein.
- 2 The equipment furnished shall be fabricated, assembled, erected, and placed in proper operating condition in full conformity with approved drawings, specifications, engineering data, and/or recommendations furnished by the equipment manufacturer.

**1.2 SUBMITTALS**

The equipment manufacturer shall submit the following items:

1. (4)- Sets of Shop Drawings, including: Main Layout Drawings, List of Equipment Specifications, and Recommendations furnished by the Equipment Manufacturer.
2. (4)- Sets As-Built Drawings of Washer Compactor Structure, Controls, and Accessories (as applicable)
3. Detailed description of how to integrate controls with the existing conveyor and two (2)- Duperon bar screen controls.
4. List of Spare Parts and Special Tools (as applicable).
5. (4)- Sets O&M Manuals (including As-Built Drawings) to be provided after equipment ships for inclusion in the close-out Submittal process.

**1.3 QUALITY ASSURANCE**

- A. The Washer Compactor shall be fully assembled and shop tested at the manufacturing facility prior to shipment. Shop testing shall include a minimum of 4 hours of run time.
- B. To assure quality and performance: All equipment furnished under this Section and related sections shall be of a single manufacturer who has been regularly engaged in the design and manufacture of the equipment and demonstrates, to the satisfaction of the City, that the quality is equal to equipment made by those manufacturers specifically named herein. And the Washer Compactor manufacturer shall have at least 25 installations of the specified model of Washer Compactor equipment that has been in successful operation, at similar installations, for at least five (5) years. Upon request, the manufacturer shall provide a reference of such installation sites along with the relevant contact information.

- C. The equipment furnished shall be fabricated, assembled, installed and placed in proper operation condition in full conformity with approved drawings, specifications, engineering data, and/or recommendations furnished by the equipment manufacturer.

#### 1.4 WARRANTY

- A. The Contractor shall expressly represent, warrant and agree that all goods, equipment, material, and fabrication provided or performed on or off City premises relative to this Contract will:
1. Be free of defects in workmanship and materials for a period of twelve (12) months after the delivery of the piping to the City.
  2. Conform in all respects to the City's specifications, requirements or other descriptions.
  3. Be fit for the purpose(s) of intended use.
  4. Be new and good quality, merchantable, of good workmanship, of materials best suited for the intended purposes, and free from defects of any kind.
- B. Any usage statement, guarantee, or warranty stated in the Bid relating to equipment, materials, service, or Work will be superseded by the terms and conditions stated herein or in their absence by the following:
1. If said equipment, material, service or Work is found to be defective in workmanship and materials, design fails, or is found to be nonconforming with the terms and conditions of this Contract with the time as specified in this section, it shall, at the City's option, be repaired or replaced at the City's location by the Contractor at absolutely no cost to the City.
  2. All items delivered or supplied hereunder will be free and clear of all liens, encumbrances, claims, and security interests of whatever nature and substance. Upon request, the Contractor will supply the City with documentation satisfactory to it evidencing the absence of such liens, encumbrances, claims, and security interests.

### PART 2 – PRODUCTS

#### 2.1 MANUFACTURERS

- A. Washer Compactor shall be as manufactured by Duperon Corporation.
- B. Or pre-approved equal. Washer Compactor manufacturer seeking pre-approval must submit application a minimum of one (1) weeks prior to bid day. The necessary submission to be considered a pre-approved equal shall include the following information:
1. Product data sheet
  2. Site Specific Proposal Drawing
  3. Installation drawings and instructions
  4. O & M Manual
  5. An employee list of in-house design engineers along with their respective locations and resumes.
  6. An employee list of in-house controls engineers along with their respective locations and resumes.
  7. An employee list of in-house application engineers along with their respective locations and resumes.
  8. An employee list of in-house project managers along with their respective locations and resumes.
  9. An employee list of in-house field service technicians along with their respective locations and resumes.

## 2.2 BASIS OF DESIGN

- A. Compacting Action:** The Washer Compactor shall have dual augers to provide positive displacement action. Augers shall be oriented on top of each other and rotate in opposing directions. Augers shall be intermeshed, with one left-hand and one right-hand lead. Augers shall be designed with a limited float on top of a strainer to allow for the accommodation of irregular debris.
- B. Washing Action:** The Washer Compactor shall have a wash water manifold integrated into the main housing. Two ports inside the unit shall emit a medium pressure stream. Wash water shall run continuously when the Washer Compactor is in motion. Continuous operation (non-batching) equipment is required; filling- and batching-type equipment shall not be accepted.
- C. Operation:** The Washer Compactor shall be continuous run, not requiring an operator. The Washer Compactor shall be equipped with a self-regulating, active pressure zone designed to accept non-standard wastewater debris in its original form, including but not limited to: rocks; broken concrete; and metal (such as bolts or short pipe) up to 4 inches long. The Washer Compactor shall have the ability to process multiple pieces of clothing, variable volumes of debris, and unprocessed septage or grease. The Washer Compactor shall move at a normal operating speed of 3.5 to 14.2 RPM and shall have the ability to run intermittently to sync with upstream equipment.
- D. Materials:**
1. **Fabrications:** All welded fabrications shall be made from stainless steel. All welded connections and welding procedures shall comply with AWS "Structural Welding Code – Sheet Steel" D1.3/D1.6.
  2. **Select Parts:** Select power transmission parts to be made from cast iron; however, shall conform to standard coating as follows.
  3. **Standard Coating:**  
  
Motor gearbox shall be coated in strict accordance with the paint manufacturer's specification. Surface preparation shall be done in accordance with SSPC-SP-10 near White. The three-part coating system shall be manufactured by Tnemec as follows: Prime Coat Series 90-97 Tnemec Zinc at 2.5-3.5 mils DFT; Intermediate Coat Series Typoxy at 3.0-5.0 mils DFT; and Top Coat Series 1075U Endura-Shield II at 2.0-3.0 mils DFT. Standard color is 11SF Safety Blue. Material shall meet all State and Federal VOC and other regulatory requirements.
  4. **Non-Metal:** Parts not covered in the specifications above shall be manufactured from UHMW polyethylene.

E. Design Conditions:

<b>Washer Compactor</b>	
<b>Peak Capacity:</b>	150 cu.ft./hr (3 minutes)
<b>Average Capacity (Continuous):</b>	42 cu.ft./hr
<b>Wastewater Application two (2) 3/4" barscreens:</b>	Up to 26 MGD Each
<b>Water: Typical</b>	<ul style="list-style-type: none"> <li>• Utilizes filtered effluent or municipal water</li> <li>• Consumes 3-10 GPM</li> <li>• Requires 40-60 PSI</li> <li>• ½ inch NPT supply (female threads)</li> <li>• 3 inch NPT drain (male threads)</li> </ul>
<b>Materials of Construction:</b>	<ul style="list-style-type: none"> <li>• 304 S316</li> <li>• 17-4 Spur Gears</li> <li>• Delrin (or equivalent) thrust and plane bearings</li> <li>• UHMW Auger Supports</li> </ul>
<b>Strainer:</b>	<ul style="list-style-type: none"> <li>• Perforated Screen</li> </ul>
<b>Performance Data (Typical Wastewater Debris)</b>	
<b>Dry Solids:</b>	30%-60%
<b>Mass/Weight Reduction:</b>	60%-70%
<b>Volume Reduction:</b>	70%-80%
<b>Odor/Fecal:</b>	Significantly decreases odor/fecal
<b>Motor/Drive</b>	
<b>Motor Size:</b>	5 HP
<b>Motor Paint:</b>	Duperon Standard Tnemec Coating
<b>Motor Service Factor (Minimum):</b>	1.0
<b>Output Speed:</b>	14.2 RPM
<b>Speed Reducer Ratio/Output:</b>	123:1
<b>Speed Reducer Paint:</b>	Duperon Standard Tnemec Coating
<b>Site Power</b>	
<b>Phase/Voltage:</b>	240/480 volt
<b>Controls</b>	
	<ul style="list-style-type: none"> <li>• NEMA 4X S316 enclosure</li> <li>• Main Disconnect</li> <li>• Emergency Stop</li> <li>• HOA (Auto is discrete "Run" input)</li> <li>• Fwd/Jog Reverse/E-Stop Push Button Station</li> <li>• "Run" and "In Auto" discrete outputs</li> <li>• Explosion-Proof station</li> </ul>
<b>Mounting:</b>	<ul style="list-style-type: none"> <li>• Wall</li> <li>• Pedestal (by others)</li> </ul>
<b>Project Management</b>	
<b>Submittal Quantity:</b>	2 - 4
<b>O&amp;M Manual Quantity:</b>	2 - 4
<b>Warranty Period:</b>	1 year
<b>Shipping</b>	
	<ul style="list-style-type: none"> <li>• Main unit</li> <li>• Chute(s)</li> </ul>

## 2.3 COMPONENTS

- A. Main Housing:** The main housing of the Washer Compactor shall be constructed of stainless steel (material options contained in table) with a minimum thickness of 11 gauge. Support and flange connections shall be 3/8 inch
- B. Hopper:** The hopper of the Washer Compactor shall be constructed of stainless steel with a minimum thickness of 11 gauge. Manufacturer shall measure and design the hopper to fit under the existing conveyor.
- C. Augers:** The augers shall be of stainless steel with 8-inch diameter flights, 3/8 inch-thick, with 4-inch flight pitch. The augers shall be coupled to a transmission at the drive end and be supported at the compaction end with UHMW plane bearings. This arrangement shall allow for the accommodation of irregular debris. The auger shaft shall be 2-inch stainless steel schedule 40 pipe with 2-inch solid stainless steel stub shaft.
- D. Compaction Housing:** The compaction housing of the Washer Compactor shall be 1/4 inch stainless steel and shall house a spring and gate assembly to provide the resistance for compaction. The compaction housing shall contain the auger supports.
- E. Discharge Chute:** The discharge chute of the Washer Compactor shall be constructed of stainless steel with a minimum thickness of 14 gauge. Support and flange connections shall be 1/4 inch. The discharge chute shall be tapered outward toward the discharge end. Manufacturer shall measure and design the discharge chute to run from the end of the conveyor to dumpster shed.
- F. Water Supply:** The water supply shall connect at a single point with a 1/2 inch NPT female connector. A NEMA 7/9 Explosion proof solenoid valve is provided to limit the wash water flow to only when the washer compactor is running. Ball valves shall be provided to distribute flow to the washing and trough sprayer connections.
- G. Strainer:** A strainer shall be located beneath the lower auger to filter the washed solids. The strainer shall be removable via drain trough and pressed against the lower auger with spring pressure. The strainer shall be self-cleaning through continuous, even contact with the lower auger. Strainers requiring auger-mounted brushes will not be accepted.
- H. Drain Trough:** A removable pan shall be provided beneath the main housing to collect wash water. Wash water shall be drained through a 3 inch NPT male drain port. The pan shall be a minimum of 11-gauge stainless steel.
- I. Drive Assembly:**
1. Each Washer Compactor unit shall operate independently, with its own drive unit and driven components. The gearbox shall not be vented to the outside atmosphere.
  2. The gearbox shall be grease lubricated and designed for 5 years (or 20,000 hours of operation) between recommended clean and re-grease services. The gearbox shall be right angle type, and shall incorporate cycloidal and spiral bevel gearing with a total ratio of 123:1. The gear reducer output shaft speed shall be 3.5 RPM minimum to 14.2 RPM maximum and controlled by an AC Tech, vector-type inverter (or greater service factor) based on unit torque requirements. It shall be shaft-mounted utilizing the keyless Taper-Grip bushing.
  3. The motor shall be mounted to the gear reducer by utilizing a quill, C-Face mounting style. The motor shall be AC induction type, 5 HP, 3/60/230/460 volt, explosion-proof, inverter-duty model.
  4. The drive assembly shall incorporate the Duperon<sup>®</sup> standard coating system.
- J. Auger Transmission:**
1. The Drive Assembly shall be coupled to a dual gear transmission, which drives the augers in a counter-rotation.
  2. The spur gears are contained in a stainless steel housing and supported by Delrin (or equivalent) plane bearing.
  3. Grease fittings shall be located outside of the transmission housing to provide lubrication to the gears.
- K. Speed Reducer:** The Speed Reducer shall have a maximum output of 14.2 RPM, 123:1 reduction ratio with 18,900 in.-lb. of output torque.
- L. Thrust Bearings:** Thrust Bearings shall be Delrin (or equivalent), self-lubricating, and be capable of withstanding a minimum of 2000 lb. of thrust load (each auger) at 14.2 RPM for life of machine.

- M. **Screw Supports:** Screw supports shall be UHWM plane type, self-lubricating, and fastened into place using stainless steel fasteners.

#### 2.4 ELECTRICAL, CONTROLS, INSTRUMENTATION

- A. **General:** Controls for the washer compactor shall be in an enclosure provided by the washer compactor manufacturer. The washer compactor manufacturer shall be responsible for proper sizing and function of the controls at 480V. **Note that the washer compactor controls must be interlocked with the main control panel of the bar screens and conveyors.**

1. Controls shall be designed to accept incoming power supply per specs and shall include a step-down transformer as needed to achieve 120V.
2. Control Panel shall be constructed to meet the appropriate NEMA classification requirements and will include a main, lockable disconnect. The panel will be constructed by a UL certified control panel build facility and will be supported by the appropriate UL labeling.
3. Controls shall be tested prior to shipment to owner. The washer compactor manufacturer shall verify all overload settings in the motor controller to insure proper overload and speed settings required for the application are properly programmed.
4. Control panel shall be wired complete with a minimum of #16 MTW wire in the appropriate colors for the circuits being supplied. 120VAC control shall be red, grounded AC neutral shall be white, DC control shall be blue, DC neutral shall be blue with a white tracer, equipment ground shall be green and all incoming and outgoing external power source wires shall be a yellow configuration. All AC power wiring shall be a minimum of #12 Black. All wires shall be labeled at both ends with heat-shrink wire markers. Internal panel wiring shall be contained in non-flammable, covered wire way.
5. All panel and panel mounted devices shall be labeled with engraved I.D. markers that reference back to the system schematics. Tags shall be white with black core, engraved as required.
6. All field wiring and power cables between the washer compactor Main Control Panel and the Local Push Button Station shall be provided by others.

**B. Components:**

**1. Main Control Panel**

- a. Enclosure shall be NEMA 4X 304 SSTL for indoor/outdoor installations.
- b. Enclosure shall not be located in a classified area.
- c. Main Control Panel shall be designed with a SCCR rating of 18KA at 480VAC minimum and labeled as such, unless otherwise specified.
- d. All terminals utilized in the main panel shall be 600V rated terminals and 20% spare terminal space shall be provided for any potential future revisions.
- e. The Main Control Panel shall include at a minimum the following
  - Main fusible disconnect with lockable operator, unless otherwise specified.
  - Physical or virtual Hand/Off/Auto (HOA) Selector and Push/pull E-Stop button.
  - Elapsed run-time meter
  - Indication for "Power On", "Forward" and necessary faults
  - Fused connection for the wash water solenoid.
- f. PLC Based Controls shall include the following:
  - Programmable Logic Controller (PLC)
  - Variable Frequency Drive (VFD)
  - HMI programmable functions as required
  - SCADA Interlocking via Hard Contact and/or Ethernet Communications Protocols as required.

**2. Local Control Push Button Station**

- a. Enclosure shall be NEMA 4/7/9 rated for Classified area. Local push button station must be local to the equipment to maintain requirements of local safety codes as determined by the City
- b. Local station shall be mounted within 10 feet or as close to the equipment as safely possible and be field wired by the electrical subcontractor to the corresponding terminal inputs in the main control panel
- c. The remote pushbutton station shall include Forward, Jog Reverse and E-Stop buttons

**3. Sequence of Operations:**

- a. The Washer Compactor controls shall enable the push button station installed near the Washer Compactor when in "Hand" mode and utilize an input signal from a remote source when in "Auto" mode. Upon receiving a disruption of "remote source" signal in "Auto" mode, the Washer Compactor shall utilize an off-delay timer to allow debris to finish depositing. The wash water solenoid is energized any time that the washer compactor is running.
- b. The Duperon' Speed Controller fault shall be cleared by turning off the Washer Compactor, then waiting approximately three minutes (or time designated per current UL standards) and then turning the HOA back to the desired setting. A motor overtemp fault shall clear automatically when the motor cools to a temperature within the normal operating range.

**4. Miscellaneous:**

The following shall be provided by the electrical contractor and are not part of the Washer Compactor manufacturer scope of supply:

- a. Mounting stands
- b. Mounting hardware
- c. Field wiring and conduit
  - VFD-rated motor cable (Belden #29502 or equal) recommended for all motors
  - Motor cables shall be less than 80 ft. long unless specified otherwise.
- d. Junction boxes
- e. Installation - Field wiring shall include (but not be limited to) the following connections as applicable:
  - All incoming power supply to the main control panel
  - All required grounding of the motor and controls.
  - Motor to the main control panel.
  - VFD-rated motor cable (Belden #29502 or equal) recommended for all motors
  - Motor cables shall be 80 ft. long unless specified otherwise.
  - Motor thermostat to the terminal inputs in the control panel.
  - Wash water solenoid wiring
  - Input and output signal wiring for remote start/stop as required by plans/specs
  - Remote station contacts to the corresponding terminal inputs in the main control panel.

**PART 3 – EXECUTION**

**3.1 SHIPMENT**

Shipment of all equipment shall be coordinated to allow the Washer Compactor shipment as one complete integrated assembly unless otherwise specified by the City.

**3.2 INSTALLATION**

**Anchor Bolts:** Anchor bolts and nuts shall be 304 stainless steel and furnished for each item of equipment by the CONTRACTOR.

1. Anchor bolt template drawings shall be included in the submittal to permit verification of the location structural elements, new or existing in the concrete.
2. Anchor bolt sizes, quantity and requirements will be indicated on the submittal drawings. Quantity is site specific but typically each Washer Compactor assembly requires (4) 1/2" dia. x 4 1/2" Lg. embed HILTI HAS RODS w/ RE-500v3 Adhesive system anchor bolts.

**3.3 TESTING**

- A. After completion of installation, Manufacturer shall provide for testing. Testing of the Washer Compactor shall demonstrate to the City that the equipment is fully operational and that the equipment will wash, compact, and deposit materials not to exceed 4 inches.
- B. Field certification shall include inspection of the following:
  1. Verify Washer Compactor is properly leveled and anchored per the installation instructions and site drawings.
  2. Assure controls and instrumentation work in all modes.
  3. Assure proper auger rotation.
  4. Check to assure all Start-Up requirements are completed per the Installation Guide.

**3.4 ONSITE TECHNICAL ASSISTANCE**

Manufacturer shall provide services to include Installation Certification, and shall include (1) day for Start-Up and (1) day for Training. Manufacturer shall be given minimum 14 days notification prior to the need for such services. To assure the best outcome for the Owner and Contractor, the Contractor shall provide certification for completion of the PRE-COMMISSIONING CHECKLIST.

**BID FORM**

Description	Unit	QTY	Amount
Washer Compactor including hopper and discharge chute for East Pumping Stations.	LOT	1	\$81,365.00
<b>TOTAL</b>			<b>\$81,365.00</b>



**All proposals will be evaluated on the following criteria:**

1. Failure to use this bid form shall result in bid disqualification.
2. Failure to bid on all items shall result in an "incomplete bid" determination.
3. List value-added considerations on a separate sheet of paper.
4. All bid pricing to include shipping and freight charges.

**THIS PAGE MUST BE COMPLETED AND INCLUDED WITH THE BID**

The undersigned hereby certifies, on behalf of the respondent named in this Certification (the "Respondent"), that the information provided in this offer submitted to the City of Flint, Department of Purchase and Supplies is accurate and complete, and that I am duly authorized to submit same. I hereby certify that the Respondent has reviewed all documents and requirements included in this offer and accept its terms and conditions.

Terms: Net 30Fed. ID #: 38 2578319Company (Respondent): Duperon CorporationAddress: 1200 Leon Scott CourtCity, State & Zip Code: Saginaw, MI 48601Phone / Fax Number: 989-401-7129 FAX: 989-754 2175Email: dherald@duperon.comPrint Name and Title: David Herald - Lead Sales Project ManagerSigned:   
(Authorized Representative)

❖ **EXHIBIT B - QUALIFICATIONS AND LICENSES REQUIREMENTS**

**Please give a synopsis of your qualifications and experience with this service.**

Duperon is the leader in simple, adaptive screening technologies and provides solutions for coarse screening, fine screening, low flow screening, ultra screening, washing compacting and conveying.

**Please list Licenses:**

Duperon is a leading Equipment Manufacturer based in Saginaw, MI

**How long have you been in business?**

Since 1985 - over 35 years

**Have you done business with the City of Flint?**

Yes

**If yes, please state the project name.**

Duperon provided two mechanical bar screens in 2013 for project - P4634 Flint MI East Pump Station

❖ EXHIBIT C – DISCLOSURE OF SUPPLIER RESPONSIBILITY STATEMENT

- 1. List any convictions of any person, subsidiary, or affiliate of the company, arising out of obtaining, or attempting to obtain a public or private contract, or subcontract, or in the performance of such contract or subcontract.

N/A

---

- 2. List any convictions of any person, subsidiary, or affiliate of this company for offenses such as embezzlement, theft, fraudulent schemes, etc. or any other offense indicating a lack of business integrity or business honesty which affect the responsibility of the contractor.

N/A

---

- 3. List any convictions or civil judgments under state or federal antitrust statutes.

N/A

---

- 4. List any violations of contract provisions such as knowingly (without good cause) to perform, or unsatisfactory performance, in accordance with the specifications of a contract.

N/A

---

- 5. List any prior suspensions or debarments by any government agency.

N/A

---

- 6. List any contracts not completed on time.

N/A

---

- 7. List any documented violations of federal or state labor laws, regulations or standards, or occupational safety and health rules.

N/A

---

---

❖ EXHIBIT D – LIST OF REFERENCES: (3) SIMILAR SCOPE OF WORK FROM  
THE LAST 5 YEARS

Providing the following contact information enables the City of Flint to contact those accounts as references.

**Reference #1:**

Company/Municipality: City of Trenton, MI  
 Contact Person: Shawn O'Day Title: IPP Coordinator/Asset Manager  
 Address: 1801 Van Horn Rd  
 City: Trenton State: MI Zip: 48183  
 Telephone: 734-676-0646 Fax: 734-675-5382  
 Email: soday@trenton-mi.com  
 Type of Project: Barscreen and washer compactor

Project Timeline (Dates): 8-12 weeks after approval Budget: \$215,000.00

**Reference #2:**

Company/Municipality: City of Warren, MI  
 Contact Person: Bryan Clor Title: Division Head  
 Address: 32360 Warkop Ave  
 City: Warren State: MI Zip: 48093  
 Telephone: 586-264-2530 Fax: \_\_\_\_\_  
 Email: bclor@cityofwarren.org  
 Type of Project: 3 Barscreens & 2 Washer Compactors

Project Timeline (Dates): 10-12 weeks after approval Budget: \$763,000.00

❖ EXHIBIT D – LIST OF REFERENCES: (3) SIMILAR SCOPE OF WORK FROM THE LAST 5 YEARS (CONTINUES)

Reference #3:

Company/Municipality: Benton Harbor - St Joseph WWTP

Contact Person: Tim Lynch Title: Plant Manager

Address: 269 Anchor Way

City: St. Joseph State: MI Zip: 49085

Telephone: (269) 983-7719 Fax: \_\_\_\_\_

Email: tlynch@qtm.net

Type of Project: Barscreen & Washer Compactor

Project Timeline (Dates): 8-12 weeks after approval Budget: \$327,000.00

**❖ EXHIBIT E – CERTIFICATE OF INSURANCE****INSURANCE REQUIREMENTS**

The Contractor shall notify all insurance agents and companies retained by the Contractor that these insurance requirements shall be included in any Agreement between the Contractor and the City of Flint.

The Contractor shall purchase and maintain, at its sole expense and as long as it is providing services to the City, the following insurance coverage:

Commercial General Liability - Occurrence form, including coverage for bodily injury, personal injury, property damage (broad form), premises/operations, blanket contractual, and products/completed operations. Coverage shall be endorsed to include the City as an additional insured for work performed by the Contractor in accordance with the Agreement.

**Minimum Limits:**

- \$1,000,000 per occurrence/\$2,000,000 general aggregate
- \$2,000,000 aggregate for products and completed operations
- \$1,000,000 personal and advertising injury

Automobile - Michigan "no-fault" coverage, and residual automobile liability, comprehensive form, covering owned, hired, and non-owned automobiles. Coverage shall be endorsed to include the City as an additional insured for work performed by the Contractor in accordance with the Agreement.

**Minimum Limits:**

- No-fault coverages - statutory
- \$500,000 per person/\$1,000,000 per accident - bodily injury
- \$500,000 per occurrence - property damage
- A combined single limit of \$1,000,000 per occurrence

Workers' Compensation and Employer's Liability- Statutory coverage or proof acceptable to the City of approval as a self-insurer by the State of Michigan.

**❖ EXHIBIT E – CERTIFICATE OF INSURANCE (CONTINUES)**

## Minimum Limits:

- Workers' Compensation - statutory
- Employer's Liability - \$100,000 each accident/\$100,000 disease - each employee
- \$500,000 disease - policy limit

Professional Liability – Covering acts, errors or omissions of a professional nature committed or alleged to have been committed by the Contractor or any of its subcontractors. Coverage shall be effective upon the date of the Agreement and shall remain effective for a period of three (3) years after the date of final payment thereunder. Such coverage shall be endorsed to include any subcontractors hired by the City.

## Minimum Limits:

- \$1,000,000 per occurrence, \$1,000,000 annual aggregate

Insurance coverage shall cover all claims against the City of Flint, its officials and employees, arising out of the work performed by the Contractor or any subcontractors under the Agreement. Should any work be subcontracted, it shall be the responsibility of the Contractor to maintain Independent Contractor's Protective Liability Insurance with limits equal to those specified above for Commercial General Liability Insurance. In addition, the Contractor shall provide proof of Workers' Compensation Insurance for all subcontractors in compliance with the required statutory limits of the State of Michigan.

Said policies of insurance shall be with companies licensed to do business in the State of Michigan and in a form satisfactory to the City. All insurance companies must maintain a rating of B+, VIII or better from AM. Best Company. Certificates of insurance with a thirty-(30) day cancellation clause shall be filed with and approved by the City at least five (5) days in advance of commencing work under the Agreement. Cancellation, material restriction, non-renewal or lapse of any of the required policies shall be grounds for immediate termination of the Agreement by the City.

The City reserves the right to request a complete certified copy of the policies for the above coverage's.

Any reduction or exhaustion in the limits of required insurance coverage shall not be deemed to limit the indemnification afforded in accordance with the Agreement or any amendments thereto.

Depending on the subject matter of the transaction, the City may require other insurance coverage in addition to the coverage's contained herein.

***THE BID NUMBER IS TO APPEAR ON ALL INSURANCE CERTIFICATES***

❖ EXHIBIT F – NON-BIDDER’S RESPONSE

VENDOR’S NAME: \_\_\_\_\_

**NON-BIDDER’S RESPONSE**

For the purpose of facilitating your firm’s response to our invitation to bid, the City of Flint is interested in ascertaining reasons for prospective bidder’s failure to respond to “Invitations to Bid”. If your firm is not responding to this bid, please indicate the reason(s) by checking any appropriate item(s) below and return this form to the above address.

We are *not* responding to this “Invitation to Bid” for the following reason(s):

\_\_\_\_\_ Items or materials requested not manufactured by us or not available to our company.

\_\_\_\_\_ Our items and/or materials do not meet specifications.

\_\_\_\_\_ Specifications not clearly understood or applicable (too vague, too rigid, etc.).

\_\_\_\_\_ Quantities too Small.

\_\_\_\_\_ Insufficient time allowed for preparation of bid.

\_\_\_\_\_ Incorrect address used. Our correct mailing address is: \_\_\_\_\_

\_\_\_\_\_ Our branch / division handles this type of bid. We have forwarded this bid on to them but for the future the correct name and mailing address is: \_\_\_\_\_

\_\_\_\_\_ OTHER: \_\_\_\_\_

**Thank you for your participation in this bid.**



FOR CORPORATION

STATE OF Michigan

S.S.

COUNTY OF Saginaw

David Herald

being duly sworn, deposes and says that she/he/they is Lead Sales Project Manager of Duperon Corporation

(Official Title)

(Name of Corporation)

a corporation duly organized and doing business under the laws of the State of Michigan the corporation making the within and foregoing bid; that they executed said bid in behalf of said corporation by authority of its Board of Directors; that said bid is genuine and not sham or collusive and is not made in the interests of or on behalf of any person not herein named, and that they have not and said bidder has not directly or indirectly induced or solicited any other person or corporation to refrain from bidding; that they have not and said bidder has not in any manner sought by collusion to secure to themselves or to said corporation an advantage over other bidders.

Subscribed and sworn to before me at Duperon Corporation in said County and State, this 17<sup>th</sup> day of May, A.D. 2021

Tina Severance

\*Notary Public, Michigan County, Saginaw

My Commission expires Sept 25, 2024

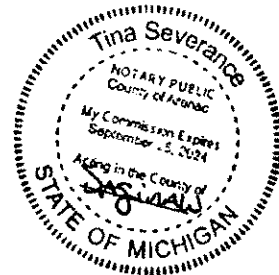



# City of Flint

## Department of Purchases & Supplies

---

Sheldon A. Neeley

TO: All Proposers  
FROM: Jennifer Ryan  
Deputy Finance Director  
DATE: May 12, 2021  
SUBJECT: Addendum #01 – Bid# 22000030 – East Pumping Station Washer Compactor

This addendum has been issued because of the following:

1. Attached are Questions and Answers
2. Listed below is the Google Meet information for the bid opening date – Tuesday, May 18, 2021 at 11:00 a.m.

Join with Google Meet

[meet.google.com/muv-koon-bnj](https://meet.google.com/muv-koon-bnj)

Meeting ID

[meet.google.com/muv-koon-bnj](https://meet.google.com/muv-koon-bnj)

Phone Numbers

(US)+1 617-675-4444

PIN: 325 251 761 3705#

All other bidding terms, requirements, and conditions continue as indicated in the remaining original bid documents.

The Deputy Finance Director, Jennifer Ryan, is an officer for the City of Flint with respect to this RFP.

In the submission of their proposal, Proposer must acknowledge receipt of this addendum. Proposer shall acknowledge this addendum by signing and returning one copy of this notice with their submission.

Company Name: Duperon Corporation

Address: 1200 Leon Scott Court

City / State / Zip: Saginaw, MI 48601

Telephone: 989-401-7129 Fax: 989-754-2175 Email: dherald@duperon.com

Print Name: David Herald Title: Lead Sales Project Manager

Signature: \_\_\_\_\_ Date: \_\_\_\_\_

Thank you.

  
Jennifer Ryan  
Deputy Finance Director

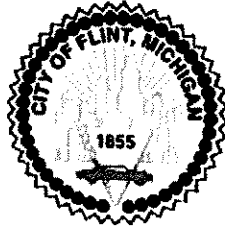

QUESTIONS RECEIVED IN THE DIVISION OF PURCHASES & SUPPLIES  
For East Pumping Station Washer Compactor  
BID# 22000030

1. During review of the bid documentation Duperon noted that it mentions performance and material payment bonds. These are often not required in an "equipment only" bid such as this one and I did not see a specific call out in the purchasing check list requiring a Bond and do not believe one is required for this project. Can you please confirm this?  
A bond is not required.
  
2. Page 22 of 37  
Section 2.4.B.1.f
  - Please advise if PLC and Ethernet functionality is required for the site.
  - Relay based and Hard Contacts to SCADA are satisfactory for the functionality of the Washer Compactor

Relay and hardwire to SCADA would be acceptable if they can give a detailed description of how that will work with the existing Bar screen. The current Duperon bar screens run all of the time due to their size and will increase or decrease based upon the upstream and downstream level sensors. What would determine when the conveyor and the compactor would run?



# City of Flint

## Department of Purchases & Supplies

---

Sheldon A. Neeley

TO: All Proposers  
FROM: Jennifer Ryan  
Deputy Finance Director  
DATE: May 14, 2021  
SUBJECT: Addendum #02 – Bid# 22000030 – East Pumping Station Washer Compactor

This addendum has been issued because of the following:

1. Attached are Revised Questions and Answers
2. Listed below is the Google Meet information for the bid opening date – Tuesday, May 18, 2021 at 11:00 a.m.

Join with Google Meet

[meet.google.com/muv-koon-bnj](https://meet.google.com/muv-koon-bnj)

Meeting ID

[meet.google.com/muv-koon-bnj](https://meet.google.com/muv-koon-bnj)

Phone Numbers

(US)+1 617-675-4444

PIN: 325 251 761 3705#

All other bidding terms, requirements, and conditions continue as indicated in the remaining original bid documents.

The Deputy Finance Director, Jennifer Ryan, is an officer for the City of Flint with respect to this RFP.

**In the submission of their proposal, Proposer must acknowledge receipt of this addendum. Proposer shall acknowledge this addendum by signing and returning one copy of this notice with their submission.**

Company Name: Duperon Corporation

Address: 1200 Leon Scott Court

City / State / Zip: Saginaw, MI 48601

Telephone: 989-401-7129

Fax: 989-754-2175

Email: dherald@duperon.com

Print Name: David Herald

Title: Lead Sales Project Manager

Signature: \_\_\_\_\_

Date: \_\_\_\_\_

Thank you.

  
Jennifer Ryan

Deputy Finance Director



**QUESTIONS RECEIVED IN THE DIVISION OF PURCHASES & SUPPLIES  
For East Pumping Station Washer Compactor  
BID# 22000030**

1. During review of the bid documentation Duperon noted that it mentions performance and material payment bonds. These are often not required in an "equipment only" bid such as this one and I did not see a specific call out in the purchasing check list requiring a Bond and do not believe one is required for this project. Can you please confirm this?  
**A bond is not required.**
  
2. Page 22 of 37  
Section 2.4.B.1.f
  - Please advise if PLC and Ethernet functionality is required for the site.
  - Relay based and Hard Contacts to SCADA are satisfactory for the functionality of the Washer Compactor**Relay and hardwire to SCADA would be acceptable if they can give a detailed description of how that will work with the existing Bar screen. The current Duperon bar screens run all of the time due to their size and will increase or decrease based upon the upstream and downstream level sensors.**
  
3. Attached please find the details of the control interface between the existing Duperon Screens and proposed new Duperon Washer Compactor.  
**See Attachment.**

## **Mechanical Screen/Washer Compactor Process Control Narrative for Flint P9450**

### Process Description

The existing facility houses two mechanical bar screening channels. All channels have manually operated slide gates at their inlet and outlet for channel isolation and/or hydraulic control. Two submersible level transducers are mounted in each channel upstream and downstream of the existing mechanical screen for screen control and alarming. Ideally, the screens will run continuously any time there is at least one foot of influent level in the channel and the screens will speed up based on a high influent level or high differential level signal.

A new washer-compactor will receive screenings from the existing Conveyor to the new washer compactor inlet hopper, and will wash, compact, and convey the screenings to a site provided disposal bin. Drainage / wash water will return to the screening channel by gravity and will be plumbed by others.

### Operation

The mechanical screens are controlled by the Screening Main Control Panel with PLC logic and door-mounted operator interface located in the control room of the Headworks building. The Screening Main Control Panel has a Hand/Off/Auto selector, elapsed run-time meter, main disconnect and indication for 'Power On', 'Forward', 'VFD Fault', and 'Motor Overtemp'. It also contains a variable frequency drive to control the speed of the multi-rake, adjustable on/off cycle timers, and hard contacts/Ethernet communication for SCADA interlock. In Hand Mode, the screen utilizes input signals from the local pushbutton panel. A local control push-button station is located directly adjacent to the multi-rake bar screen, and includes 'Forward', 'Jog Reverse' and 'E-Stop' buttons. These buttons enable the operator to reverse the direction of the rake movement to address service issues, and allow for emergency shut-down. In Auto Mode, the mechanical screens are controlled by the Screening Main Control Panel. Under normal flow conditions, when the differential level, as measured by the two submersible level transducers, is between the low (level TBD) and high (level TBD, less than 12") set points, the screens operate continuously at a normal speed/speed proportional to the differential. If the differential level is below the low set point, the screens will operate intermittently, as controlled by a cycle timer in the Main Control Panel at an operator-adjustable interval. If the differential level exceeds the high set point, the screen will move to high speed operation in an attempt reduce blinding. When the upstream channel level exceeds the high channel level setpoint, the screen will start (if not already running based on differential level) and operate at high speed. An alarm is also sent to SCADA, as this could indicate a blockage in the mechanical screen or abnormal flow condition that requires operator attention. The motor thermostat will shut down the equipment if motor over-temperature condition occurs.

The existing Conveyor located behind the screens runs when either screen is running and has an off delay timer to continue running for a period of time once both screens have shut off. The conveyor will deposit the screenings into the new washer compactor inlet hopper. The washer-compactor will be controlled by its own Washer Compactor Main Control Panel to be located in the control room of the building. The Washer Compactor Main Control Panel will be Relay Logic based and include a

Hand/Off/Auto selector, speed controller, elapsed run-time meter, push-to-test indicator lights for 'Power On', 'Forward', 'VFD Fault', and 'Motor Overtemp'. It will also contain a variable frequency drive to control the speed of the augers, and hard contacts for SCADA interlock. In Hand Mode, the washer-compactor will utilize input signals from the local pushbutton panel. A new local pushbutton panel for the washer-compactor will be located adjacent to the washer-compactor, and will include 'Forward', 'Jog Reverse' and 'E-Stop' buttons. In Auto Mode, the washer-compactor will be controlled by the Washer Compactor Main Control Panel, and will operate whenever the existing conveyor is operating. The speed of the compactor augers will be controlled by a user adjustable VFD and will be set to run from the factory at a normal speed of (30Hz). The wash water solenoid valve will be open whenever the washer compactor is running to wash and flush the washer compactor perforated plate strainer. In the absence of an input signal or upon receiving a stop signal in Auto mode, an off-delay timer allows debris to finish depositing, including upon cessation of mechanical screen operation. The motor thermostat will shut down the Washer Compactor if motor over-temperature condition ever occurs as well as send an alarm to SCADA.



**Date:** May 17, 2021

**Proposal #9450 R2**

**Project:** East Pumping Station Washer Compactor  
BID #22000030

**Bid Date:** May 18, 2021 @ 11 00 AM Local Time

**Substantial Completion:** TBD

**Addendum:** No. 1, 2

**Owner:** The City of Flint  
Finance Department – Division of Purchases and Supplies  
1101 S. Saginaw St Room 203 2<sup>nd</sup> Floor  
Flint MI 48502

**Duperon Contact:**

David Herald – Lead Sales Project Manager  
dherald@duperon.com

Steve Aiken - Regional Sales Manager  
saiken@duperon.com  
(989) 401-7110

**Local Representation:**

Jay Vermilye  
DuBois-Cooper Associates  
(248) 935-4456 Phone  
905 Penniman Ave.  
Plymouth MI 48170  
jvermilye@duboiscooper.com

**To: The City of Flint**

Duperon is pleased to offer the following scope of supply including washer compactor and accessories as listed in the scope of supply.

We appreciate the opportunity to provide the following pricing for the washer compactor requirements at the City of Flint East Pumping Station Washer Compactor project. We look forward to the opportunity to work with you and thank you for your consideration.

**Note: Duperon equipment is the basis of design for the washer compactor for this project.**





**Scope of Supply:**

**Specification Sections:** ITB-B22000030 Exhibit A with Addendum 2 Controls Changes to Relay Logic

**(1) Duperon® Washer Compactor - Dual Auger System – Indoor Installation**

- **Model WC3.C2.5**
    - 5HP Motor and gearbox
    - 3.15 ft from operating deck to top of washer compactor hopper rim
    - 3.56 ft long hopper length
    - 1.45 ft wide hopper width
      - Inlet Hopper will be customized / designed in Submittals to fit site
      - Accepting debris from two Duperon Bar Screens via a common conveyor
    - SSSL304 materials of construction
  - **Reduced Maintenance**
    - Accepts variable debris up to four inches, including rocks, clothing, concrete metal grease and septage – eliminating jams and equipment shutdown
    - Positive displacement technology assures that all debris which enters the hopper is washed, compacted, and discharged for disposal
    - Durable dual auger design eliminates debris wrapping
    - Non-clogging flood wash port located prior to compaction housing – ideal for non-potable water
  - **Reduced Odor**
    - Up to 60% dry solids and up to 60% mass/weight reduction – significantly reducing fecal content and odor
  - **Reduced Landfill Costs**
    - Up to 84% volume reduction
    - Self-Regulating Compaction Housing – allows for consistent dry solids output regardless of fluctuations in debris volume
  - **Reduced Power Consumption**
    - ¼ HP inverter duty motor consumes just 576 watts
    - Requires .4 KWH
- Discharge chute design
- Up to 10.00 ft long discharge chute with, (1) bend
- Water supply and drain criteria
- Non-Clog Flood Washing
  - Utilizes filtered effluent or municipal water
  - Consumes 3 to 10 gallons per minute at 40 to 60 PSI
  - 3.00 inch NPT male drain connection
  - 0.50 inch NPT water supply connection

---

**Estimated Anchor Bolts Needed for Washer Compactor:**

---

Estimated Anchor Bolts Needed (not included in scope of supply – by Others/Contractor):

- **Anchor Bolts**
  - Bolts for anchor toes and plates
  - (4) 12 mm (1/2 inch) diameter x 115 mm (4-1/2 inch) long Embed HAS Rods w/ Hilti RE-500-V3 Adhesive System
- Above quantities not guaranteed as accurate final quantities will be outlined in submittals.

**(1) Controls Package, Main Panel**

- **NOTE: Referencing NFPA 820, the main control panel shall be removed from the equipment/channel by a minimum of 10 feet.**
- Main fusible disconnect for incoming power 480V/60hz/3ph
- Wall mount NEMA 4X SSSL304 enclosure
- Enclosure to be
  - Located in an unclassified area

BID  
Proposal Number  
P9450 R2

East Pumping Station Washer Compactor  
BID #22000030



- Located where temperatures drop below 0°C (32°F) frequently
- Not Located where temperatures exceed 40°C (105°F) frequently
- Enclosure to include equipment
  - (1) Washer Compactor with 5HP motor driven by AC Tech VFD with panel mounted keypad
- Relay Based logic, to include
  - Pilot lights, push buttons and selector switches on front door
  - Terminal blocks, ETMs, breakers, and relays where required
  - Hand-Off-Auto selector switch uses PB station in Hand mode
  - Hard contact SCADA Interlock(s) Run, No Fault, Auto, High Level Remote start
  - Adjustable off delay timer
  - Machine runs when remote start is made and continues for an adjustable time after signal is removed
  - Line reactor
- Weather protection devices inside enclosure
  - Heater, fan, thermostat and rain hoods for fan assembly

Instrumentation

- None, not needed

Local to equipment mounted devices

- (1) Three Button NEMA 4/7/9 Enclosure for E-Stop, Jog-Reverse and Forward

Washer Compactor Spare Parts

- (2) Upper/Lower Support Auger
- (2) Side Support Auger
- (24) FHCS 0.25-20x1
- (24) 0.25 Flat Washer SAE
- (24) 0.25 Nylock Nut
- (1) 1 oz. Never Seez
- (1) 14 oz grease tube

On Site Technical Assistance

- (1) Trip(s)
- (1) Technician
- (2) 8 hour man-day(s) total on site
- *If additional Technical Service days are required, please add per the rates included in the Clarifications section of this scope of supply*

Operation and Maintenance Manuals

- 6 Hard Copies

Warranty

- One Year Standard material and workmanship

Freight to Jobsite

---

Price: \$61,365.00

Price is valid for 120 days from bid date.

---

Delivery:

- Submittals, 4-6 weeks after approved purchase order, based on workload
- Equipment Delivery 8-12 weeks after approval based on workload
- FOB Jobsite Freight Paid



---

**Exceptions:**

---

- Controls are Bid Relay Logic - per Addendum 2
- Duperon is not providing installation – by others / contractor.

---

**Clarifications:**

---

General Clarifications

- Prices are valid for 120 days unless stated otherwise in the proposal
- See Duperon Contractor Installation Guides for guidance in estimating these costs
- Duperon requires 3 week's advanced notice in writing to schedule field service technician on site.
- Field Services will be provided as outlined in this proposal. Duperon field service rate is \$750 per day plus travel and per diem expenses. If field service personnel arrive on site as scheduled and the project is not ready for intended services to be performed, Duperon will invoice for additional days, if required. If the time required is greater than the time listed in this proposal, Duperon will invoice at the above rates.
- The specifications listed are the only specifications which shall apply to this proposal either directly or by reference. Any additional specifications, with equipment or requirements specified therein, that are not specifically included as part of this offer are excluded from this proposal.

Washer Compactor Clarifications

- Some minor field assembly required
- Water supply and discharge piping by others
- Mounting hardware by others

Controls Clarifications

- All conduit and field wiring between the equipment by others
- Mounting hardware by others

---

**Not Included:**

---

- Anything not specifically stated in this Proposal.
- Bonding, tariffs, permits, taxes, liquidated damages
- Construction and/or installation work of any kind at the jobsite.
- On-site conditions affecting the work described or which affects the installation.
- Conduit, stands, control mounting wiring, junction boxes or other accessories.
- Any site work or installation tasks (i.e., unloading, placement, dewatering, diving, clearing the forebay, wiring, provision of concrete structure, etc.), equipment (such as cranes, hammer drills, etc.), or anchor bolts.
- Pre-installation tasks such as touch-up painting, checking bolts for tightness, removal of shipping containment devices, etc.
- Engineering: Does not include drawings other than those for the FlexRake.
- Additional structure for seismic or wind conditions.
- Offloading or handling of delivered equipment.
- Union labor for all field support services.
- Controls not specifically listed above.
- Videotaping of the training sessions
- Release of proprietary information
- Insulation or weather proofing.
- Site/field painting or touch up.
- Vibration and noise testing.
- Anchor Bolts by others.
- Discharge system.
- Stilling wells.

**BID**  
Proposal Number  
P9450 R2

**East Pumping Station Washer Compactor**  
BID #22000030



---

**Payment Terms:**

- 5% Due with placement of order
- 20% Invoiced upon submittal of engineering drawings
- 65% Invoiced at time of shipment
- 10% Invoiced upon successful start up or 60 days after shipment, whichever is less.
- All payments are due Net 30 days
- Based upon review and approval by Duperon credit department
- No retentions allowed

---

**Proposal Terms:**

- This offer is subject to the enclosed Duperon Corporation Terms and Conditions page unless alternate terms and conditions are specifically negotiated in writing and are signed/accepted by Duperon Corporation at the time of purchase.
- May be subject to material price escalation.
- This proposal is based upon the information available at this time and may be impacted by future specifications, scope, and other requirements.
- Duperon Corporation retains the right to revise, withdraw, or negotiate this offer at any time prior to signing a material contract.

---

**Order Processing:**

To facilitate timely order processing and submittals, refer to this proposal number and please list purchaser contact, telephone, fax, and email with your purchase order. Please provide with your order a copy of trade references and, if tax exempt, please provide a resale or tax exemption certificate. Purchase Order should be sent to and payment remitted to

Duperon Corporation  
1200 Leon Scott Court  
Saginaw, MI 48601  
Ph. 800-383-8479  
Fax 989-754-2175

---

**Approved for Purchase by:**

\_\_\_\_\_  
Signature

\_\_\_\_\_  
Date

\_\_\_\_\_  
Printed Name

\_\_\_\_\_  
Title

\_\_\_\_\_  
Company Name & Address

## Duperon Corporation Terms and Conditions

The Terms and Conditions ("Terms") contained herein shall apply to any and all Equipment sales by Duperon Corporation, Inc ("Duperon Corporation") to Purchasers ("Purchasers"). These Terms apply in lieu of any course of dealing between the parties or usage of trade in the industry. Any changes in the Terms contained herein must specifically be agreed to in writing and signed by Duperon Corporation before becoming binding on either party. The sale and purchase of Equipment described herein shall be governed exclusively by the foregoing and the following Terms:

- 1 **ACCEPTANCE:** Any prior Duperon Corporation price quotation or pricing letter is for Purchaser's information only. Duperon Corporation shall only be bound by written confirmation of acceptance of the proposal. All Purchaser orders and agreements are expressly conditioned upon assent to these terms and conditions. Terms additional to or different from those in these terms and conditions are rejected. Duperon Corporation and Purchaser agree that these terms and conditions are accepted in good faith by both parties as the controlling terms and conditions notwithstanding Section 2-207 of the Uniform Commercial Code, as enacted. Duperon Corporation's commencement of performance is not to be construed as acceptance of any of Purchaser's terms or conditions. Duperon Corporation may commence performance in reliance on Purchaser's acceptance of these terms and conditions.
- 2 **SPECIFICATIONS:** The proposal or Equipment may not be in strict compliance with the Engineer's/Owner's plans, specifications, or addenda as there may be deviations. The Equipment will meet the mechanical specifications as described by Duperon Corporation.
- 3 **ITEMS INCLUDED:** Duperon Corporation's offer includes only the listed Equipment and does not include erection, installation, accessories or associated materials such as controls, piping, etc.
- 4 **PARTIES TO CONTRACT:** Duperon Corporation is not a party to or bound by the terms of any other Purchaser contract, agreement, or understanding with third-parties and Duperon Corporation's duties are limited to this proposal with Purchaser to which there are no intended third-party beneficiaries.
- 5 **PRICE AND DELIVERY:** All selling prices quoted are subject to change without notice after 30 days from the date of a proposal unless specified otherwise. Unless otherwise stated, all prices are F.O.B. Duperon Corporation or its supplier's shipping points with freight allowed. All claims for damage, delay or shortage shall be made by Purchaser directly against the carrier. When shipments are quoted F.O.B. job site or other designation, Purchaser shall inspect the Equipment shipped, notifying Duperon Corporation of any damage or shortage within forty-eight hours of receipt. Failure to so notify Duperon Corporation shall constitute acceptance by Purchaser, relieving Duperon Corporation of any liability for shipping damages or shortages.
- 6 **PAYMENTS:** All invoices are net 30 days. Delinquencies and failure to pay after demand by Duperon Corporation are subject to a 1.5% service charge per month or the maximum permitted by law, whichever is less, on all past due accounts. Pro rata payments are due as shipments are made. If shipments are delayed by the Purchaser, invoices shall be sent on the date when Duperon Corporation is prepared to make shipment and payment shall become due under standard invoicing terms. If the work to be performed hereunder is delayed by the Purchaser, payments shall be based on percentage of completion. Unless specifically stated otherwise, prices quoted are for Equipment only. If at any time the financial condition of the Purchaser gives Duperon Corporation, in its judgment, doubt concerning the Purchaser's ability to pay, Duperon Corporation may require full or partial payment in advance or may suspend any further deliveries or continuance of the work to be performed by Duperon Corporation until such payment has been received or terminate its contract.
- 7 **CREDIT APPLICATION:** Purchaser must complete a credit application if it wishes credit terms. The provision of credit is subject to acceptance by Duperon Corporation's Credit Department and its requirements.
- 8 **RETENTIONS:** Retentions are not included, unless specifically noted. Purchaser agrees not retain payment or any part of a payment. Failure to make payment in accordance with the agreed upon terms will result in a 1.5% per month service charge.
- 9 **ESCALATION:** If shipment is, for any reason, deferred by the Purchaser beyond the contractually agreed upon normal shipment date, or if material price increases (or decreases) are greater than 5% from proposal date to material procurement date, stated prices set forth herein are subject to a shared risk escalation adjustment. Any escalation less than plus or minus 5% shall be absorbed by Duperon Corporation. All escalation (increase or credit) that exceeds 5% shall be passed onto the Purchaser at cost and shall be based upon increases (or decreases) in material costs to Duperon Corporation that occur in the time period between quotation and material procurement by Duperon Corporation. Purchaser agrees to this potential escalation (or credit) regardless of contradicting terms in the contract, except when an agreed upon escalation adder is included in the price.
  - (a) The total quoted revised price is based upon changes in the indices as published by third party sources, such as: the United States Department of Labor, Bureau of Labor Statistics. Labor will be related to the Average Hourly Earnings indices found in the Employment and Earnings publication. Material will be related to the Metal and Metal Products Indices published in Wholesale Prices and Price Indices.
  - (b) Price revision for items furnished to, and not manufactured by Duperon Corporation, which exceed the above escalation calculation, will be passed along by Duperon Corporation to Purchaser based upon the actual increase in price to Duperon Corporation for the period from the date of quotation to the date of material procurement. Any item that is so revised will be excluded from the index escalation calculations set forth in subparagraph (a) above.
- 10 **BACKCHARGES:** Duperon Corporation will not approve or accept back charges for labor, materials, or other costs incurred by Purchaser or others in modification, adjustment, service, or repair of Duperon Corporation furnished materials unless such back charge has been authorized in advance in writing by a Duperon Corporation employee, by a Duperon Corporation purchase order, or work requisition signed by Duperon Corporation.
- 11 **APPROVAL:** If approval of Equipment submittals by Purchaser or others is required, a condition precedent to Duperon Corporation supplying any Equipment shall be such complete approval.

## Duperon Corporation Terms and Conditions

- 12 **INSTALLATION SUPERVISION:** Unless specified, prices quoted for Equipment do not include installation supervision or on-site technical advice. Duperon Corporation recommends and will, upon request, make available, at Duperon Corporation's then current rate, an experienced installation supervisor to act as the Purchaser's agent to supervise installation of the Equipment. Purchaser shall at its sole expense furnish all necessary labor, Equipment, and materials needed for installation. Responsibility for proper operation of Equipment if not installed by Duperon Corporation or installed in accordance with Duperon Corporation's instructions and inspected and accepted in writing by Duperon Corporation, rests entirely with Purchaser, and any work performed by Duperon Corporation personnel in making adjustment or changes must be paid by Purchaser at Duperon Corporation's then current per diem rates plus living and traveling expenses. Duperon Corporation shall not be responsible for results in connection with the installation of the Equipment or technical advice not provided or furnished by Duperon Corporation.
- 13 **ACCEPTANCE OF PRODUCTS:** Products will be deemed accepted without any claim by Purchaser unless written notice of nonacceptance is received by Duperon Corporation within 30 days of delivery if shipped F.O.B. point of shipment, or 48 hours of delivery if shipped F.O.B. point of destination. Such written notice shall not be considered received by Duperon Corporation unless it is accompanied by all freight bills for said shipment, with Purchaser's notations as to damages, shortages and conditions of Equipment, containers, and seals. Non-accepted products are subject to the return policy stated below.
- 14 **TAXES:** Any federal, state, or local sales, use or other taxes applicable to this transaction, unless specifically included in the price, shall be the responsibility of Purchaser.
- 15 **TITLE:** The Equipment shall, regardless of the manner in which affixed to or used in connection with realty, remain the sole and personal property of Duperon Corporation until the full purchase price has been paid. Purchaser agrees to do all things necessary to protect and maintain Duperon Corporation's title and interest in and to such Equipment; and upon Purchaser's default, at Duperon Corporation's option, Duperon Corporation may retain as liquidated damages any and all partial payments made and shall be free to enter the premises where such Equipment is located and remove the same as its property without prejudice to any further claims on account of damages or loss which Duperon Corporation may suffer from any cause.
- 16 **INSURANCE:** From date of shipment until the invoice is paid in full, Purchaser agrees to provide and maintain at its expense, but for Duperon Corporation's benefit, adequate insurance including, but not limited to, builders risk insurance on the Equipment against any loss of any nature whatsoever. Purchaser shall provide proof of said coverage prior to shipment.
- 17 **SHIPMENTS:** Any estimated delivery dates represent Duperon Corporation's best estimate. No liability, direct or indirect, is assumed by Duperon Corporation for failure to ship or deliver on such dates. Duperon Corporation shall have the right to make partial shipments; and invoices covering the same shall be due and payable by Purchaser in accordance with the payment terms thereof. If Purchaser defaults in any payment when due hereunder, Duperon Corporation may, without incurring any liability therefore to Purchaser or Purchaser's customers, declare all payments immediately due and payable with maximum legal interest thereon from due date of said payment, and at its option, stop all further work and shipments until all past due payments have been made, and/or require that any further deliveries be paid prior to shipment. If Purchaser requests postponements of shipments, the purchase price shall be due and payable upon notice from Duperon Corporation that the Equipment is ready for shipment, and thereafter any storage or other charge Duperon Corporation incurs on account of the Equipment shall be added to Purchaser's account. If delivery is specified at a point other than Duperon Corporation or its supplier's shipping points, and delivery is postponed or prevented by strike, accident, embargo, or other cause beyond Duperon Corporation's reasonable control and occurring at a location other than Duperon Corporation or its supplier's shipping points, Duperon Corporation assumes no liability for delivery delay. If Purchaser refuses such delivery, Duperon Corporation may store the Equipment at Purchaser's expense. For all purposes of this agreement such tender of delivery or storage shall constitute delivery.
- 18 **WARRANTY:** DUPERON CORPORATION WARRANTS EQUIPMENT IT SUPPLIES ONLY IN ACCORDANCE WITH THE WARRANTY EXPRESSED IN THE ATTACHED COPY OF "DUPERON WARRANTY" AGAINST DEFECTS IN WORKMANSHIP AND MATERIALS WHICH IS MADE A PART HEREOF. SUCH WARRANTY IN LIEU OF ALL OTHER WARRANTIES, INCLUDING WARRANTIES OF MERCHANTABILITY AND FITNESS FOR PARTICULAR PURPOSE, WHETHER WRITTEN, ORAL, EXPRESSED, IMPLIED OR STATUTORY, DUPERON CORPORATION SHALL NOT BE LIABLE ANY CONTINGENT, INCIDENTAL, OR CONSEQUENTIAL DAMAGES FOR ANY REASON WHATSOEVER. THE PARTIES AGREE AND STIPULATE THAT AN EXPRESS WARRANTY PROVIDED TO PURCHASER IN WRITING IS THE SOLE WARRANTY REGARDING THE PRODUCT AND ANY SERVICE PROVIDED BY DUPERON CORPORATION. THE PARTIES SPECIFICALLY AGREE AND STIPULATE THAT THERE IS NO OTHER WARRANTY OF ANY TYPE WHATSOEVER, INCLUDING BUT NOT LIMITED TO CONSUMER WARRANTIES, WARRANTY OF FITNESS FOR PARTICULAR PURPOSE, WARRANTY OF MERCHANTABILITY, AND DUPERON CORPORATION IS NOT LIABLE FOR ANY SPECIAL, CONSEQUENTIAL, OR ANY OTHER DAMAGES EXCEPT AS SET FORTH IN THESE TERMS AND THE EXPRESS WARRANTY. THERE ARE NO WARRANTIES WHICH EXTEND BEYOND THE FACE OF THE EXPRESS WARRANTY.
- 19 **PATENTS:** Duperon Corporation agrees that it will, at its own expense, defend all suits or proceedings instituted against Purchaser and pay any award of damages assessed against it in such suits or proceedings, so far as the same are based on any claim that the said Equipment or any part thereof constitutes an infringement of any apparatus patent of the United States issued at the date of this Agreement provided Duperon Corporation is given prompt notice in writing of the institution or threatened institution of any suit or proceeding and is given full control of the defense, settlement or compromise of any such action, and Purchaser agrees to give Duperon Corporation needed information, assistance, and authority to enable Duperon Corporation so to do. In the event said Equipment is held or conceded to infringe such a patent, Duperon Corporation shall have the right at its sole option and expense to a) modify the Equipment to be non-infringing, b) obtain for Purchaser the license to continue using said Equipment, or c) accept return of the Equipment and refund to the Purchaser the purchase price thereof less a reasonable charge for the use thereof. Duperon Corporation will reimburse Purchaser for actual out-of-pocket expenses, exclusive of legal fees, incurred in preparing such information and rendering such assistance at Duperon Corporation's request. The foregoing states the entire liability of Duperon Corporation, with respect to patent infringement; and except as otherwise agreed to in writing, Duperon Corporation assumes no responsibility for process patent infringement.

## Duperon Corporation Terms and Conditions

20. **CANCELLATION, SUSPENSION, OR DELAY:** After acceptance by Duperon Corporation, the proposal, or Purchaser's order based on the proposal, shall be a firm agreement and is not subject to cancellation, suspension, or delay except upon payment by Purchaser of appropriate charges which shall include all costs incurred by Duperon Corporation to date of cancellation, suspension, or delay plus a reasonable profit. Additionally, all charges related to storage and/or resumption of work, at Duperon Corporation's plant or elsewhere, shall be added to Purchaser's sole account. If Duperon Corporation stores Purchaser's product upon request, Purchaser agrees to be invoiced and pay, as if the product shipped according to schedule and all risks incidental to storage shall be assumed by Purchaser. Duperon Corporation shall have the right to cancel any order or proposal without notice to Purchaser in the event that Purchaser becomes insolvent, adjudicated bankrupt, petitions for or consents to any relief under any bankruptcy reorganization statute, or becomes unable to meet its financial obligations in the normal course of business.
21. **RETURN OF PRODUCTS:** No products may be returned to Duperon Corporation without Duperon Corporation's prior written permission. Said permission may be withheld by Duperon Corporation at its sole discretion.
22. **EXTENDED STORAGE:** Extended storage instructions will be part of the information provided at shipment. If Equipment installation and start-up is delayed more than 30 days, the storage instructions must be followed to keep WARRANTY in force.
23. **INDEMNIFICATION AND HOLD HARMLESS:** Duperon Corporation and Purchaser agree to hold harmless the other party from any and all liabilities, damages, losses, claims, demands, payments, actions, fees, or judgments arising out of or resulting from injury to or death of any and all persons or from damage to or loss of property (or loss of use thereof) arising out of the sale, use, maintenance, and/or delivery of Equipment provided such liabilities, damages, losses, claims, demands, payments, actions, fees, or judgments are caused by actual, or claimed, negligence or breach of warranty and do not arise from any warranty not approved or from any sales for a purpose not authorized, nor liabilities, damages, losses, claims, demands, payments, actions, fees or judgments caused in part by Purchaser's negligence or willful misconduct. Purchaser agrees to indemnify Duperon Corporation from all costs incurred, including but not limited to court costs and reasonable attorney fees, from enforcing any provisions of this contract, including but not limited to breach of contract or costs incurred in collecting monies owed on this contract.
24. **LIMITATION OF REMEDIES:** Duperon Corporation's liability shall be limited to the obligation to repair or replace only those portions or parts of Equipment proven to have failed to meet in material respect the mechanical specifications as described by Duperon Corporation or for defects in workmanship or materials as described in the Duperon Corporation Warranty in Section 18. Duperon Corporation's cumulative liability in any way arising from or pertaining to any Equipment sold to Purchaser shall not in any case exceed the purchase price paid by Purchaser for said Equipment. **IN NO EVENT SHALL PURCHASER HAVE ANY LIABILITY FOR COMMERCIAL LOSS, CLAIMS FOR LABOR, CLAIMS BASED ON DELAY, OR ANY CONTINGENT, CONSEQUENTIAL, OR INCIDENTAL DAMAGES OF ANY TYPE, WHETHER PURCHASER'S CLAIM BE BASED IN CONTRACT, TORT, WARRANTY, EQUITY, STRICT LIABILITY, OR OTHERWISE. IT IS EXPRESSLY AGREED THAT PURCHASER'S REMEDIES EXPRESSED IN THIS PARAGRAPH ARE PURCHASER'S SOLE AND EXCLUSIVE REMEDIES AT LAW OR IN EQUITY.**
25. **FORCE MAJEURE:** Neither party shall be considered in default hereunder or be liable for any failure to perform or delay in performing any provisions of this Agreement in the customary manner to the extent that such failure or delay shall be caused by any reason beyond its control, including an act of God, fire, explosions, hostilities or war (declared or undeclared), striking or work stoppage involving either party's employees or governmental restrictions, provided that the party declaring force majeure shall give notice to the other party promptly and in writing of the commencement of the condition, the nature, and the termination of the force majeure condition. The party whose performance has been interrupted by such circumstances shall use every reasonable means to resume full performance of these Terms as promptly as possible.
26. **ENTIRE AGREEMENT:** This proposal expresses the entire agreement between the parties hereto superseding any prior understandings, either written or oral, and is not subject to modification except by a writing signed by an authorized officer of each party. Any terms and conditions of any purchase order or other offer issued by Purchaser in connection with the subject matter of Duperon Corporation's proposal which are in addition to or inconsistent with these terms and conditions, will not be binding on Duperon Corporation in any manner whatsoever unless accepted by Duperon Corporation in writing.
27. **APPLICABLE LAW AND ARBITRATION:** This contract shall be governed by, and construed and enforced in accordance with, the laws of the State of Michigan. Any controversy or claim arising out of or relating to the performance of any contract resulting from the Equipment, the proposal, or the breach thereof, shall be settled by binding arbitration filed in Saginaw County, Michigan, in accordance with the Arbitration Rules of the American Arbitration Association and the parties agree to irrevocable personal jurisdiction in Michigan. Judgment upon the award rendered by the arbitrator(s) may be entered to any court having jurisdiction.
28. **NOTICES:** Unless otherwise stated, Purchaser shall deliver notices in writing via certified mail or reputable overnight courier (postage prepaid) to Duperon Corporation, 1200 Leon Scott Court, Saginaw, MI 48601. Notices delivered in this manner become effective upon Duperon Corporation's actual receipt. Duperon Corporation's notices to Purchaser may be delivered via email, facsimile, ordinary or certified mail, reputable overnight courier, or invoice and are effective when sent.
29. **MISCELLANEOUS:** Titles and/or headings in these Terms are inserted for convenience only and are not intended to affect the interpretation or construction of the Terms. Whenever possible, each provision of this Contract shall be interpreted in such a way as to be effective and valid under applicable law. If any provision is prohibited by or invalid under applicable law, it will be ineffective only to the extent of such prohibition or invalidity, without invalidating the remainder of such provision or the remaining provisions of the Terms. The parties agree that time is of the essence. No assignment of any right or obligation under this Contract shall be made by either party without the prior consent of both parties and all others are void. Failure or inability of either party to enforce any right hereunder shall not waive any right in respect to any other or future rights or occurrences. The parties deem that this Agreement was executed and to be fully performed in Saginaw, Michigan.



RESOLUTION NO.: 210266

PRESENTED: JUN - 6 2021

ADOPTED: \_\_\_\_\_

BY THE CITY ADMINISTRATOR:

**RESOLUTION TO FISHBECK FOR COMPREHENSIVE REGULATORY COMPLIANCE ASSISTANCE**

WHEREAS, the Water Pollution Control (WPC) facility must maintain comprehensive regulatory compliance assistance to enable it to respond properly and cost effectively to a variety of regulatory, legal, and engineering requirements. WPC recommended the purchase of comprehensive regulatory compliance assistance for FY2021, FY2022, and FY2023 to the only responsive bidder Fishbeck at \$100,000 per year.

Account Number	Account Name	Amount
590-550.100-801.000	Professional Services	\$100,000.000
	<b>FY2022 GRAND TOTAL</b>	<b>\$100,000.00</b>

IT IS RESOLVED, that the appropriate City Officials are authorized to do all things necessary to enter into the second year of the contract with Fishbeck, Thompson, Carr, & Huber Inc to provide comprehensive regulatory compliance assistance for FY2022, pending the adoption of the budget, for the amount of \$100,000.00.

APPROVED AS TO FORM:

Angela Wheeler  
Angela Wheeler (May 24, 2021 16:35 EDT)  
Angela Wheeler, Chief Legal Officer

APPROVED AS TO FINANCE:

Shelbi Frayer  
Shelbi Frayer (May 25, 2021 05:58 EDT)  
Shelbi Frayer, Chief Financial Officer

FOR THE CITY OF FLINT:

CLYDE D EDWARDS  
CLYDE D EDWARDS (May 27, 2021 13:33 EDT)  
Clyde Edwards, City Administrator

APPROVED BY CITY COUNCIL:

\_\_\_\_\_  
Kate Fields, City Council President

APPROVED AS TO PURCHASING:

Jennifer Ryan  
Jennifer Ryan (May 24, 2021 16:31 EDT)  
Jenn Ryan, Deputy Finance Director



CITY OF FLINT



PROPOSAL #21000533

RESOLUTION NO: 200320

PRESENTED: AUG 10 2020

ADOPTED: 8-10-2020

BY THE CITY ADMINISTRATOR:

RESOLUTION TO FISHBECK FOR COMPREHENSIVE REGULATORY COMPLIANCE ASSISTANCE

The Division of Purchases & Supplies solicited proposals for Comprehensive Regulatory Compliance Assistance as requested by the Department of Public Works.

Fishbeck, 5913 Executive Drive, Lansing, Michigan 48911, was the sole responsive bidder for said requirements.

Funding for said services will come from the following accounts for FY21 (07/01/20 - 06/30/21):

Table with 3 columns: Account Number, Account Name, Amount. Row 1: 590-550.100-801.000, Professional Service, \$100,000.00. Row 2: FY21 (07/01/20 - 06/30/21) Total, \$100,000.00

IT IS RESOLVED, that the proper city officials are to do all things necessary to enter into a contract with Fishbeck for Comprehensive Regulatory Compliance Assistance in the amount not to exceed \$100,000 for FY21 (07/01/20 - 06/30/21) and pending FY22 budget for the amount of \$100,000.00, and pending FY23 budget for the amount of \$100,000.00.

APPROVED AS TO FORM: Angela Wheeler, Chief Legal Officer

APPROVED AS TO FINANCE: Amanda Trujillo, Acting Chief Financial Officer

FOR THE CITY OF FLINT: Clyde Edwards, City Administrator

APPROVED BY CITY COUNCIL: Monica Galloway, City Council President

APPROVED AS TO PURCHASING: Joyce A. McClane, Purchasing Manager



CITY OF FLINT

RESOLUTION STAFF REVIEW FORM

TODAY'S DATE: 07/24/2020

BID/PROPOSAL# 21000533

AGENDA ITEM TITLE: Comprehensive Regulatory Compliance

PREPARED BY Jeanette Best
WPC Manager

VENDOR NAME: FishBeck

BACKGROUND/SUMMARY OF PROPOSED ACTION:

Approval to proceed with a three(3) year contract with Fishbeck, Thompson, Carr, and Huber (FTCH) to provide Comprehensive Regulatory Compliance Assistance for the Water Pollution Control Facility in the amount of \$100,000.00 per year for fiscal years 2021, 2022, and 2023 (pending budget adoption), with an overall funding limit of \$300,000.
WPCF must maintain this support service to enable it to respond properly and cost effectively to a variety of regulatory, legal, and engineering requirements. The FY 2021 tasks include updates to the Capacity Management study required by the NPDES permit, negotiation of a new NPDES Permit, and the implementation of Local Limits for the IPP (Industrial Pretreatment Program), which call for specialized expertise.
These efforts are a continuation of projects performed under a previous contract. FTCH has performed well under that contract.
Please issue a contract for the FY2021 budgeted amount of \$100,000.00, using funds from account 590-550.100-801.000.

FINANCIAL IMPLICATIONS: None

BUDGETED EXPENDITURE? YES [X] NO [ ] IF NO, PLEASE EXPLAIN:

Table with 5 columns: Dept., Name of Account, Account Number, Grant Code, Amount. Rows include DPW-WPC Professional Service, FY20/21 GRAND TOTAL \$100,000.00, and THREE YEAR TOTAL \$300,000.00.



**CITY OF FLINT**

**PRE-ENCUMBERED?** YES  NO  **REQUISITION NO:** 200002929

**ACCOUNTING APPROVAL:** \_\_\_\_\_ **Date:** \_\_\_\_\_

**WILL YOUR DEPARTMENT NEED A CONTRACT?** YES  NO   
*(If yes, please indicate how many years for the contract)* YEARS

**WHEN APPLICABLE, IF MORE THAN ONE (1) YEAR, PLEASE ESTIMATE TOTAL AMOUNT FOR EACH BUDGET YEAR: (This will depend on the term of the bid proposal)**

**BUDGET YEAR 1** \$100,000.00

**BUDGET YEAR 2** \$100,000.00

**BUDGET YEAR 3** \$100,000.00

**OTHER IMPLICATIONS (i.e., collective bargaining):** None.

**STAFF RECOMMENDATION: (PLEASE SELECT):**  **APPROVED**  **NOT APPROVED**

**DEPARTMENT HEAD SIGNATURE:** \_\_\_\_\_  
*Jeanette H. Best*  
(Jeanette Best, WPC Manager)



# City of Flint

## Department of Finance Division of Purchases & Supplies

---

Sheldon A. Neeley

July 16, 2020

**TO:** Jeanette Best  
Krystal Wallace  
(WPC)

**FROM:** Joyce A. McClane  
Purchasing Manager

**SUBJECT:** SEALED BIDS

Attached is one (1) bid that was received for **PROPOSAL #21000533 - COMPREHENSIVE REGULATORY COMPLIANCE ASSISTANCE**. Enclosed are copies for your file. **Bid Due Date: 7/16/20. Enclosed is a spreadsheet.**

Your staff review and recommendation form is needed as soon as possible. **Please use the new fillable form.** This form is to be used for your staff review.

A staff review must be completed for ALL **Bids/Proposals**. Please let me know if you need a copy of the fillable form.

This project has been identified that multiple departments use this item. Please get with those departments to determine the total usage and the amount that needs to go to Council for approval. **This proposal is good for 3 years.**

**Please note:** If your project is being funded by any grants issued by the federal government, you must go to:  
<https://www.dol.gov/ofccp/regs/compliance/preaward/debarlst.htm> to ensure that the selected vendor has not been debarred.

**PLEASE NOTE:**

Results may be viewed next business day online EXCEPT when a bid is under review. The bidders/public will only see the names of the bidders that submitted a bid, not their cost. This will protect the bidders cost in case there is a re-bid.

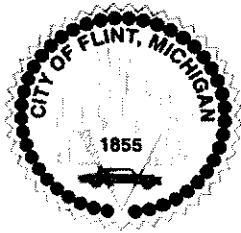

Sheldon A. Neeley

# City of Flint

## Department of Finance

### Division of Purchases & Supplies

---

Today's Date:

Please complete the following form if you decide to rebid:

**Proposal #** \_\_\_\_\_

**DETAILED REASON FOR WANTING TO REBID:**

**Authorized Signature and Title:**

**Date Signed**

.....

**PURCHASING USE ONLY**



**SEALED PROPOSALS RECEIVED IN THE DIVISION OF PURCHASES & SUPPLIES**  
**For 3-Yr. Comprehensive Regulatory Compliance Assistance**  
**PROPOSAL #21000533**  
**Company: Fishbeck – Lansing, Michigan**  
 Approximate Annual Quantities – Not Guaranteed  
 Furnish as requested for the period 7/1/20 – 6/30/23

## Rate Schedule

*June 13, 2020*

Principal		\$243
Architect   Construction Engineer/Manager/Administrator   Engineer   Estimator   Geologist   Hydrogeologist   Industrial Hygienist   Interior Designer   Project Manager   Scientist   Surveyor		
	Senior Level	\$135-\$235
	Mid Level	\$122-\$135
	Staff Level	\$79-\$122
Architectural Specialist   Engineering Specialist   Environmental Specialist   Health & Safety Specialist   Operations Specialist   Technical Specialist   Project Superintendent   Survey Specialist		
	Senior Level	\$141-\$212
	Mid Level	\$101-\$141
	Staff Level	\$79-\$101
Technician		
	Senior Level	\$110-\$128
	Mid Level	\$93-\$110
	Staff Level	\$70-\$93
Production Support		
		\$82
Photocopies	\$0.10/Copy	
Mileage/Passenger Vehicles	\$0.70/Mile	
Field and Service Vehicles	\$0.95/Mile (\$37/day min.)	
Equipment Schedule	Separate Schedule	
Expenses and Outside Services	Cost Plus 10%	

Compensation to be at one and one-half times the hourly rate for approved overtime.

Invoices are rendered every four weeks and payment is due upon receipt. A service charge of 1% per four-week period is added to accounts unpaid after 28 days from date of billing.



# **CITY OF FLINT 3-YR COMPREHENSIVE REGULATORY COMPLIANCE ASSISTANCE**

**PROPOSAL NO. 21000533**

**5913 EXECUTIVE DRIVE, SUITE 100, LANSING, MI 48911  
517.882.0383 | [INFO@FISHBECK.COM](mailto:INFO@FISHBECK.COM)**





5913 Executive Drive, Suite 100  
Lansing, Michigan 48911

517.882.0383 | fishbeck.com

June 24, 2020

Ms. Joyce A. McClane, CPPB  
Purchasing Manager  
City of Flint  
Finance Department – Division of Purchasing and Supplies  
1101 South Saginaw Street, Room 203, 2<sup>nd</sup> Floor  
Flint, MI 48502

**Request for Proposals (RFP) No. 2100533**  
**3-Year Comprehensive Regulatory Compliance Assistance**

Dear Ms. McClane:

Fishbeck is pleased to present our proposal to provide as needed regulatory assistance at the City's WPCF for fiscal years 2021, 2022, and 2023.

Fishbeck is a full-service firm with a staff of over 450 highly qualified personnel with 14 offices in Michigan, Ohio, and Indiana. Having primarily served Michigan-based clients since 1956, we have a hard-earned reputation for integrity, quality, innovation, and efficiency. This reputation is best demonstrated by our numerous long-term relationships with clients, like Flint, as well as the many awards received by our staff and our client's projects. We are proud of our steadfast commitment to 100-percent employee ownership, which helps motivate our staff to produce top quality work products and seek full client satisfaction.

The Fishbeck project team, complemented by our in-house staff, has the expertise and experience to meet most of the WPCF's regulatory compliance assistance needs. For those situations where specialized services are warranted, we will work with City staff to identify and select qualified subconsultants to add to the team. This helps ensure the City's regulatory requirements are met accurately and cost-effectively. Such an enhanced team approach has been highly successful for our regulatory assistance contracts with the City over the past 18 years and, if selected for this contract, we plan to similarly proceed for the next 3 years.

We look forward to continuing our work with the WPCF staff on this critical assignment, and appreciate the opportunity to offer our proposal. If you have any questions or require additional information, please contact us.

Sincerely,

Jeffrey J. Brown, PE  
Principal | Senior Vice President





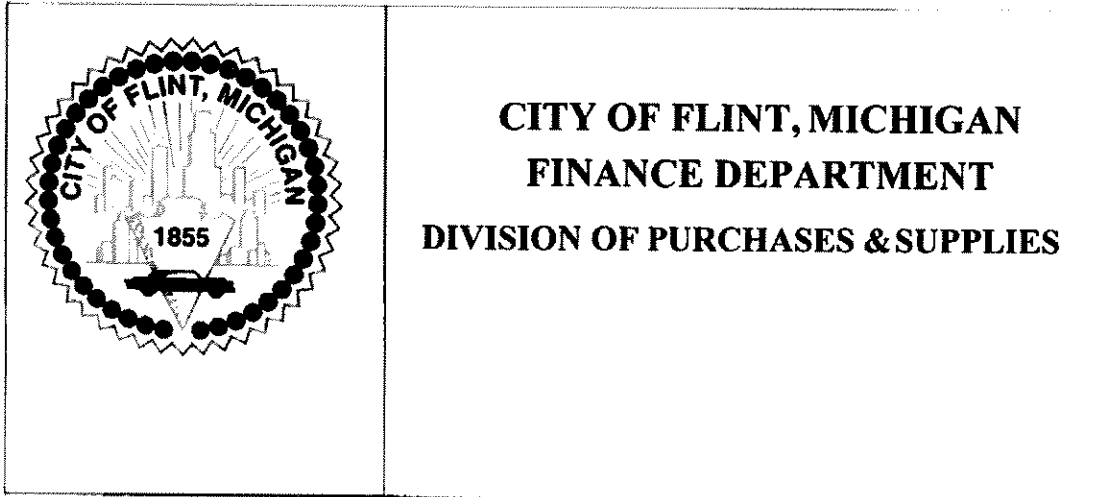

**ADDENDUM No. 1**

**PROPOSAL #** 21000533  
**ITB TITLE:** (3) YR COMPREHENSIVE REGULATORY COMPLIANCE ASSISTANCE  
**ISSUE DATE:** June 15, 2020

**To all potential bidders:**

This addendum is being issued to extend the bid due date from June 17, 2020 at 1:00 PM

**TO:**

**Extended Bid Date: Thursday, June 25, 2020 @ 1:00 PM.**

If your firm is interested in providing the requested services, please submit one (1) original and one (1) unbound copy of your detailed bid to the City of Flint, Finance Department of Purchases and Supplies, 1101 S. Saginaw St., Room 203, Flint, MI, 48502, by **June 25, 2020 at 1:00 PM (EST)**. Please note: all detailed bids received after 1:00 PM (EST) will not be considered. Bids must be in a sealed envelope clearly identifying the proposal and number. Faxed bids are not accepted.

All information contained herein is binding on all Bidders who respond to this ITB.

**ALL OTHER TERMS AND CONDITIONS REMAIN THE SAME.**

**Acknowledgement**

Name of the Firm:	
Fishbeck	
Signature/Title:	
<i>Jeffrey J. Brown</i>	Principal   Sr. Vice President
Date:	June 23, 2020

# TABLE OF CONTENTS

---

TITLE PAGE

COVER LETTER

PROPOSAL FORM

## 01 — PROJECT PROPOSAL

- + FISHBECK COMPANY INFORMATION
- + PROJECT UNDERSTANDING AND APPROACH

## 02 — PROJECT PORTFOLIO

- + COMPREHENSIVE REGULATORY COMPLIANCE ASSISTANCE EXPERIENCE
- + FLOW MONITORING SERVICES
- + FLOW MONITORING AND MODELING EXPERIENCE
- + GRANT + FUNDING ASSISTANCE INFORMATION

## 03 — DESIGN BUDGET

- + SCHEDULE/COST OF SERVICES
- + RATE SCHEDULE

## 04 — TEAM QUALIFICATIONS

- + PROJECT TEAM DESCRIPTION
- + ORGANIZATIONAL CHART
- + RESUMES OF KEY PERSONNEL

## 05 — REFERENCES

## 06 — REQUIRED FORMS

- + CERTIFICATE REGARDING DEBARMENT, SUSPENSION, AND OTHER RESPONSIBILITY MATTERS
- + INSURANCE CERTIFICATE
- + CITY OF FLINT AFFIDAVIT

# FISHBECK COMPANY INFORMATION



**COMPANY NAME:** Fishbeck

**WEBSITE:** [www.fishbeck.com](http://www.fishbeck.com)

## OFFICE LOCATIONS:

### MICHIGAN

Grand Rapids | 1515 Arboretum Drive, SE, Grand Rapids, MI 49546 | 616.575.3824  
 Ann Arbor | 2001 Commonwealth Boulevard, Suite 200, Ann Arbor, MI 48105 | 734.864.7700  
 Canton | 44978 Ford Road, Suite A, Canton, MI 48187 | 734.454.7566  
 Detroit | 1001 Woodward Avenue, Suite 860, Detroit, MI 48226 | 313.293.3550  
 Kalamazoo | 4775 Campus Drive, Kalamazoo, MI 49008 | 269.375.3824  
 Lansing | 5913 Executive Drive, Suite 100, Lansing, MI 48911 | 517.882.0383  
 Macomb | 45200 Card Road, Suite 128, Macomb Township, MI 48044 | 586.412.1406  
 Novi | 39500 MacKenzie Drive, Suite 100, Novi, MI 48377 | 248.324.2090  
 Traverse City | 921 West Eleventh Street, Suite 2E, Traverse City, MI 49684 | 231.463.5981

### OHIO

Cincinnati | 11353 Reed Hartman Hwy, Suite 500, Cincinnati, OH 45241 | 513.469.2370  
 Columbus | One East Campus View Boulevard, Columbus, OH 43235 | 614.363.1001  
 Dayton | 1167 Lyons Road, Building E, Dayton, OH 45458 | 937.291.9092  
 Toledo | 3220 Central Park West, Toledo, OH 43617 | 419.841.4704

### INDIANA

Indianapolis | 8520 Allison Pointe Boulevard, Suite 100, Indianapolis, IN 46250 | 317.577.9050

**TYPE OF COMPANY:** Employee-owned Corporation

**ESTABLISHED:** 1956

**TOTAL PERSONNEL OF FIRM:** 450

## FIRM HISTORY:

Fishbeck is a professional architectural/engineering, civil engineering, environmental, and construction services consulting firm that serves governmental, educational, healthcare, commercial, industrial, and private clients. Our range of services and integrated project approach provides our clients with specifically suited, innovative designs. We are committed to delivering exceptional service, outstanding technical quality, and establishing long term client relationships.

Our projects range from small feasibility, planning, and regulatory studies to very large design and construction projects. Our architectural/engineering division has complete building design capabilities with architects and structural, mechanical, and electrical engineers. Our civil engineering division consists of experienced civil engineers, surveyors, stormwater/drainage experts, and landscape architects. The environmental division is a mix of environmental engineers, chemists, biologists, chemical engineers, air quality experts, compliance/regulatory specialists, geologists, hydrogeologists, certified safety professionals, and wetland experts. Our construction division offers construction management and design/build services.

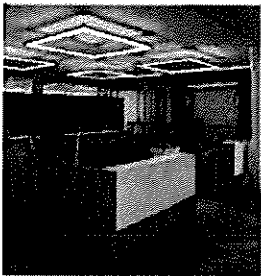

**PHILOSOPHY:**

Fishbeck is a 100-percent employee-owned corporation that believes in the straightforward philosophy of providing outstanding service to our clients with our core values being:

- Enthusiasm & Intensity
- Honesty & Integrity
- Innovation & Excellence in Everything We Do
- A Concern & Respect for People and Their Personal & Professional Growth

These four values result in the **most important value: EXCEPTIONAL CLIENT SERVICE.**

At Fishbeck, **our core purpose** is to “help people realize their visions while benefiting society.”

Fishbeck’s **mission** is to meet our clients’ needs and achieve our business goals in a manner that exemplifies our core values. Our mission basics include:

- Provide innovative and excellent designs within budget.
- Work in a supportive and synergistic way with other team members of all disciplines.
- Consider the client a project team member.
- Know the program requirements and meet them in the simplest, most constructible, cost-effective manner.
- Align expectations with clients’ needs, budgets, and the scope of our services.
- Conduct preschematic multidiscipline brainstorming.
- Keep cost estimates updated, the client informed, and design to stay within approved estimates.
- Conduct QA/QC reviews at appropriate milestones to minimize redesign.
- Minimize addenda, bulletins, and change orders.

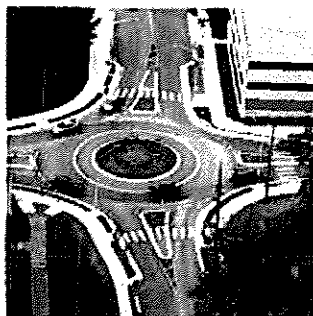
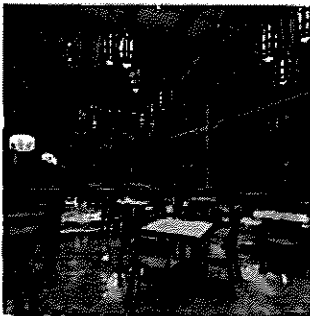

**ARCHITECTURE/  
ENGINEERING**

- Architecture
- Mechanical
- Electrical
- Structural
- Interior Design
- Systems Commissioning
- Indoor Air Quality
- Master Planning
- Facility Condition Assessment
- Energy Assessment

**INFRASTRUCTURE  
ENGINEERING**

- Site Development
- Transportation
- Surveying
- Water Distribution
- Water Supply/Treatment
- Water Storage
- Watershed Management
- Wastewater Collection
- Wastewater Treatment
- GIS/Computer Mapping
- Asset Management
- Stormwater Management

**ENVIRONMENTAL**

- Remediation
- State and Federal Environmental Program Assistance
- Air Quality
- Brownfield Redevelopment
- Water Resources
- Industrial Hygiene
- Asbestos/Lead Management
- Environmental Site Assessment
- Due Diligence

**CONSTRUCTION**

- Construction Management
- Design/Build
- Cost Estimating
- Scheduling
- Preconstruction
- Reconstruction and Cost Reduction Studies

## REGULATORY ASSISTANCE PROGRAM

Residents of the Great Lakes basin are stewards for 20% of the earth's usable fresh water. As a result, many communities in this region face challenging regulatory requirements for wastewater discharge.

Fishbeck's Regulatory Assistance Program (RAP) offers communities a path through the wastewater regulatory labyrinth. Created to be flexible for use on an as-needed basis, this program offers a unique combination of experience, expertise, and modern technology.

Our staff is recognized across Michigan for WWTP regulatory expertise. We have longstanding professional relationships with many of the EGLE representatives who administer these rules and regulations. We also are regular presenters on wastewater related topics at the Michigan Water Environment Association's conferences and seminars.

Some of the RAP services offered by Fishbeck are:

- NPDES Permits
- Renewal Applications
- Draft Permit Reviews
- Negotiations with the EGLE
- Industrial Pretreatment Program (IPP)
- Permitting of Nondomestic Users
- Categorical Standards
- Local Limits for Compatibles and Inorganic/Organic Toxics
- Special Alternative Limits (SALs)
- Extra-Strength Surcharge Rate Reevaluations
- Program Development - Manual of Procedures, Sewer Use Ordinance, Enforcement Response Plans
- Mercury Minimization
- Program Development
- Annual Status Reporting
- Enforcement Actions
- Technical Support to Legal Counsel

With access to all of Fishbeck's in-house resources, RAP clients have a direct link for addressing related spinoff issues such as Source Detection Studies, Capital Improvement Plans, Wet-Weather Flow Reduction, Infrastructure Asset Management, Air Quality Support, Structural and Architectural Assessments, and Safety/Risk Management.

References of communities with RAP successes are available upon request.



# WRAP CLIENT LOCATIONS

**67**  
CLIENTS

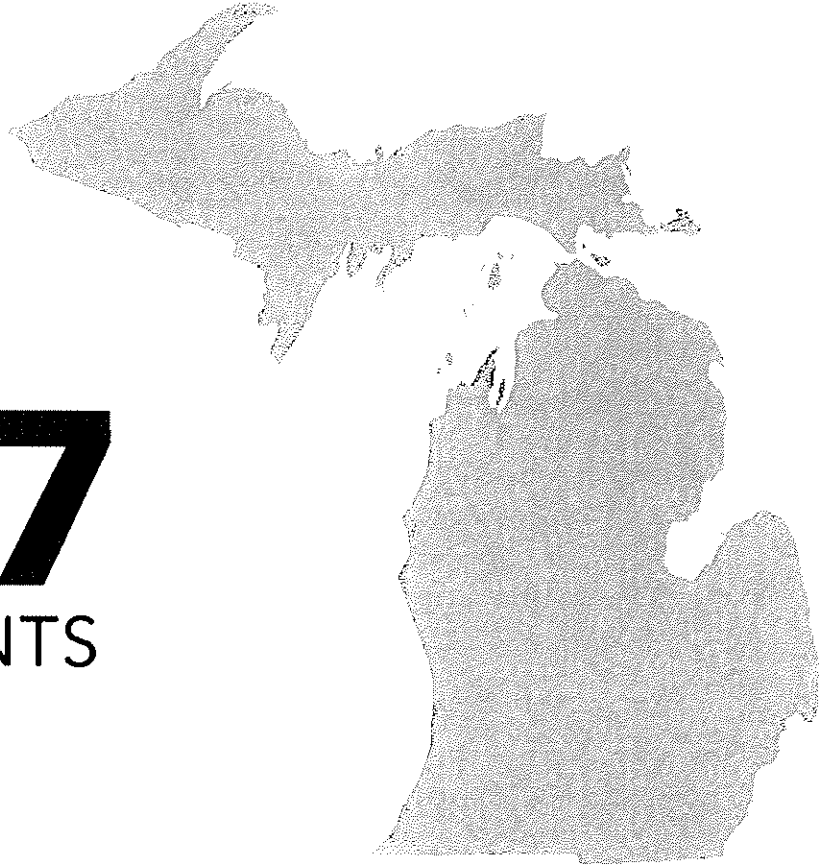

Brighton Township  
City of Adrian  
City of Ann Arbor  
City of Bad Axe  
City of Bay City  
City of Big Rapids  
City of Brighton  
City of Charlevoix  
City of Charlotte  
City of Cheboygan  
City of Chelsea  
City of Croswell  
City of Flint  
City of Frankenmuth  
City of Grand Ledge  
City of Grand Rapids  
City of Hastings  
City of Hillsdale

City of Holland  
City of Howell  
City of Ionia  
City of Ithaca  
City of Jackson  
City of Kalamazoo  
City of Lansing  
City of Lapeer  
City of Litchfield  
City of Ludington  
City of Mackinac Island  
City of Manistee  
City of Marshall  
City of Marquette  
City of Mason  
City of Midland  
City of Milan  
City of Mt. Clemens

City of Negaunee  
City of New Baltimore  
City of Otsego  
City of Owosso  
City of Petoskey  
City of Plainwell  
City of Pontiac  
City of Port Huron  
City of Reed City  
City of Richmond  
City of Saline  
City of Sault Ste. Marie  
City of South Lyon  
City of St. Clair  
City of St. Johns  
City of Warren  
City of Wyoming  
Northfield Township

Oakland County  
Scio Township  
South Huron Valley  
Southern Clinton County Municipal  
Utilities Authority  
Village of Armada  
Village of Manchester  
Wayne County/South Huron Valley  
Wayne County/Wyandotte  
Ypsilanti Community Utilities Authority  
Coldwater Board of Public Utilities  
Delta Charter Township  
Genesee County  
Lakewood Wastewater Authority

 fishbeck

## SPECIAL ALTERNATIVE LIMITS (SALS)

Local limits under an IPP are commonly determined using a uniform allocation methodology. While providing the required environmental protection, this approach restricts treatment plant utilization and development of the local economy.

Due to reduced flows and pollutant loads, many communities are experiencing issues with WWTP utilization and operating margins. Many communities also have industrial users that, if allowed, could discharge more while paying extra-strength surcharges. Local limit allocations can be viewed as pieces of a pie that represents the Maximum Allowable Headworks Loading (MAHL). Like a real pie, there is nothing left when all the pieces have been claimed.

A uniform local limit, while straightforward to implement, has several disadvantages:

- Artificially depletes available capacity by allocating load to industrial users which do not need it.
- Offers minimal flexibility to accommodate special needs of certain industrial users.
- Reduces surcharge revenue by requiring pretreatment of compatible pollutants, even when the WWTP is underutilized.

SALs represent an alternate local limit allocation approach which is rapidly gaining popularity. Conceptually, SALs are simply an extension of the uniform allocation method:

- Set aside a portion of the MAHL as reserve.
- Uniformly allocate what remains.
- When SAL assigned, withdraw from reserve.

Fishbeck is a recognized leader in preparing SAL programs for those seeking increased flexibility and surcharge revenues. Typical services include reevaluation of local limits with a SAL reserve, written procedures for assigning and accounting for SALs, and user-friendly Excel® software for continuous monitoring of the WWTP allocation status.

With this expertise and Fishbeck's decades of wastewater/IPP experience, available capacity can become an asset for enhancing operating margins while promoting development of the local economy.

## SURCHARGE RATE EVALUATIONS

Many communities find it beneficial to regularly reevaluate extra-strength surcharge rates to reflect current wastewater treatment costs. Outdated rates may decrease justifiable revenues, prevent some users from paying their fair share, or place an undue economic burden on other users.

To help maintain up-to-date surcharge rates, Fishbeck has developed a software package to accurately determine O&M costs to treat extra-strength discharges of compatible pollutants from nondomestic sources. Calibrated with the site-specific process configuration and performance/cost data, this software is linked with a state-of-the-art computer program using USEPA models for municipal treatment facilities.

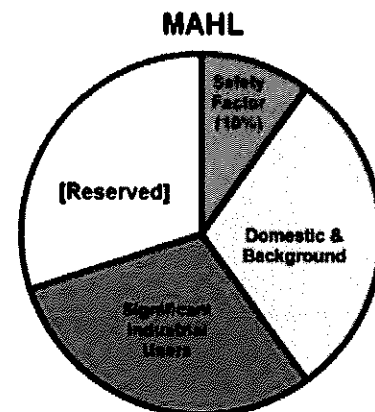
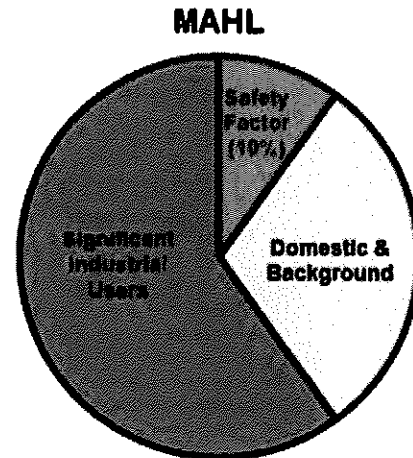



**WASTEWATER**

- Raw Sewage Pumping
- Equalization
- Screening/Grit Removal
- Primary Sedimentation
- Secondary Treatment via Activated Sludge, Oxidation Ditch, Biotower, Rotating Biological Contactor, or Lagoon
- Nitrification
- Secondary Clarification
- Chemical or Biological Phosphorus Removal
- Tertiary Filtration
- Chlorination/Dechlorination or UV Disinfection

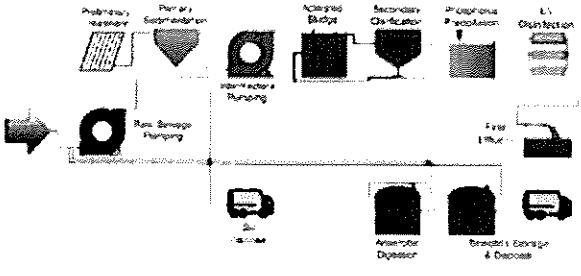

**BIO-SOLIDS**

- Anaerobic or Aerobic Digestion
- Gravity Thickening, Belt Filter Press Dewatering, or Drying Beds
- Disposal using Incineration, Landfill, or Land Application

When combined with Fishbeck's experience in wastewater treatment and industrial pretreatment programs, this software provides an efficient tool to determine both the breakdown of current O&M costs and the unit costs of treatment for incremental loadings of surchargeable pollutants.

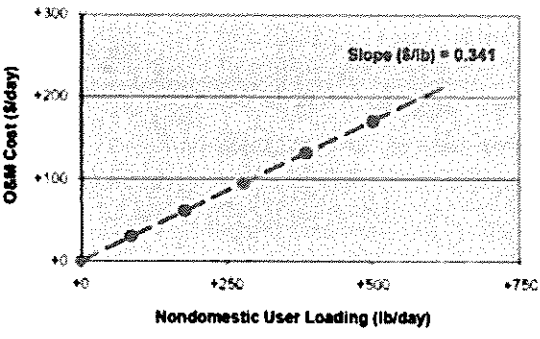
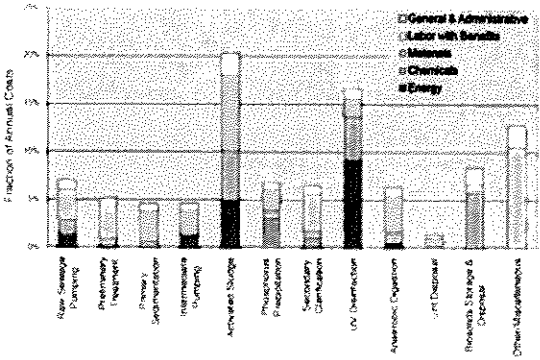

## Project Understanding and Approach

Fishbeck understands the City seeks a qualified consultant to provide as-needed support for the City of Flint – Water Pollution Control (WPC) regulatory compliance program during fiscal years 2021, 2022, and 2023. We also understand the City's needs are dependent on specific issues that arise during that time, so this contract's scope of services must remain flexible.

### THE PAST AND PRESENT...

Our ability to respond to the City's needs is best demonstrated by our performance on the WPC's Regulatory Assistance Program over the past 18 years. We successfully provided services for a wide range of projects, including the tasks highlighted below:

#### NPDES Permit Negotiations

Helped WPC staff and the City's attorney negotiate the renewal of Flint's NPDES discharge permits with the Michigan Department of Environmental Quality (MDEQ), now the Michigan Department of Environment, Great Lakes & Energy (EGLE). Evaluated conceptual designs and costs of retention basin options to mitigate wet weather overflows. Developed a master plan for the Mercury Minimization Program. Provided technical expertise resulting in the MDEQ's acceptance of a less restrictive effluent limit for low-level mercury.

#### Industrial Pretreatment Program (IPP)

Performed a headworks loading reevaluation of the WPC for compatible pollutants. Assisted in negotiations with the MDEQ that led to the approval of a flexible Special Allocation Limit (SAL) program for regulating the City's industrial users. Provided technical consultation to the City's attorney for drafting a new sewer use ordinance. Helped develop a headworks load accounting system, which provides the City with a tool for the straightforward monitoring of pollutant allocations to non-domestic users.

#### Wet Weather Management

Worked with the City to select metering locations, assist with installation and troubleshooting, and provide data analysis for over 30 locations throughout the system from the onset of the City's Flow Metering program nearly 18 years ago.

Prepared a detailed map of the City's overall collection system (pictured below) using as-built drawings provided by the City. Developed a dynamic hydraulic model of main trunk lines using a commercial software package (XP-SWMM). Helped WPC staff purchase new and replacement flow meters for the collection system and provided field support to install/relocate these meters at selected points across the City. Assisted in the installation of cell modems in select locations to automate the meter data uploading process, relieving some time constraints for busy field staff. Fishbeck routinely worked with WPC staff to review metering data and determine locations for future flow metering.

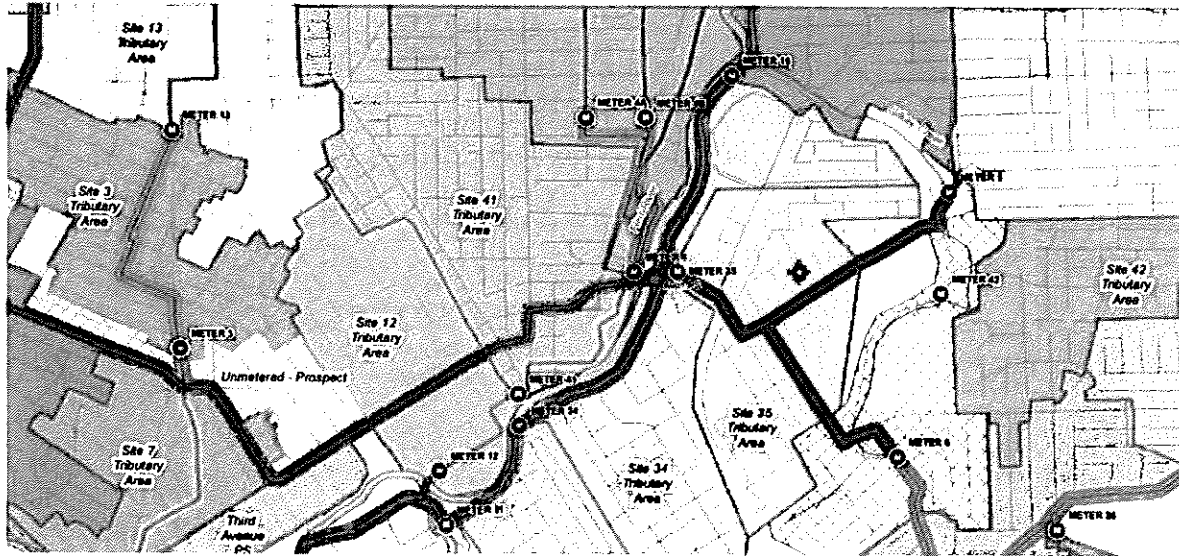

Prepared an extensive flow capacity report in accordance with NPDES permit requirements. Helped conduct evaluations aimed at determining whether the system can achieve the MDEQ's wet weather capacity standard (i.e., 25-year/24-hour storm event during growth conditions and normal soil moisture). Prepared capacity assessment reports in accordance with NPDES permit requirements. Provided data from a temporary flow meter to help WPC staff identify suspicious discharges from a non-domestic user (OilChem).

### Asset Management

Advised on the WPC's capital improvements program for improving and upgrading the plant. Investigated biosolids disposal options, including capital/O&M cost estimates of alternatives. Evaluated influent and effluent flow measurement systems, leading to improvements and improved accuracy. Provided structural repair assessment of influent junction chamber and primary tank influent channels. Provided technical support to upgrade the WPC grit removal system. Provided design services to improve the chlorine gas system, including evaluating sodium hypochlorite as an alternate chemical for disinfection. Provided design services to repair and replace components of system feeding polymer to the solids dewatering process. Helped evaluate the reactivation of anaerobic digester tanks for proposed waste-to-energy modifications; performed structural assessment of necessary repairs. Provided electrical engineering support for motor control center upgrade, leading to new monitoring instrumentation and improved process control. Performed architectural assessment of a former process building to control deterioration during idle period. Assisted with the evaluation of upgrade alternatives for the Northwest Pump Station to improve pumping efficiency, reliability, and effectiveness.

### Other Regulatory Support

Provided technical assistance to update the WPC's Process Safety Management (PSM) program, ensuring compliance with federal regulations for highly hazardous chemicals. This included an audit of the overall program and updating PSM documentation.

Provided Risk Management Plan (RMP) consulting services including conducting the required RMP audit, submitting the RMP renewal, and updating the City's RMP documentation.

## **THE FUTURE...**

As the City moves to another 3-year WPC regulatory compliance program, Fishbeck is eager to continue to provide the regulatory services the City needs. We anticipate the following tasks and associated activities, as follows.

### **Task 1 — NPDES Permit Negotiation and Support**

Fishbeck is prepared to continue assisting the City with NPDES permit negotiations and related activities. Our team is fully knowledgeable in the state and federal wastewater regulations, and has longstanding relationships with EGLE staff.

Our experience with the City's permit, as well as NPDES permits in general, could be useful for negotiating the term of the anticipated draft NPDES permit. We also would be available for assisting with Whole Effluent Toxicity (WET) tests, administrating the Mercury Minimization Program, addressing issues that may arise related to PFAS or other emerging contaminants of concern, assisting in the City's response to EGLE on an NPDES-related enforcement action, and other general permit-required activities.

### **Task 2 — Wet Weather Management**

Fishbeck is prepared to continue providing as-needed assistance to evaluate the collection and treatment system's capacity for flows relative to EGLE's wet weather standard.

Combining our experience with the City's previous flow studies with the now fully operational XP-SWMM model, we could seek to further define the site-specific relationship between rainfall intensity to plant flows. This would involve the ongoing assessment of collection system details, updating system maps, and evaluating collected data on plant flows, river elevations, and rainfall.

We could continue evaluating the data collected from flow meters installed in the collection system, including additional updates to the XP-SWMM model. The City completed a SAW Grant in 2018 which included an update to the City-wide sewer system GIS database. This allows for the opportunity to expand the hydraulic model into upstream areas of the system that may be of interest to the City. These areas may include portions of the system that are susceptible to sanitary sewer overflow or an area that is a candidate for future rehabilitation. We will also provide guidance on additional metering recommended to define the flow characteristics of the given areas.

We could also continue identifying area(s) within the model boundaries where the predicted flow exceeds the collection system's capacity and quantifying any additional storage volume and/or source removal required to meet the wet weather capacity standard. We have previously used the hydraulic model and metering data to identify sewersheds with excessive inflow and infiltration that should be targeted for future investigation. This is an evolving process that would be beneficial to reevaluate annually, as areas of the system are rehabilitated, and new data flow measurements are collected.

Fishbeck can also provide recommendations on where to focus on future flow monitoring efforts. We understand the collection system group continues to line sewers in localized areas where there are structural issues that can also affect infiltration. We can provide assistance with post-sewer lining flow metering to quantify flow reductions from sewer rehabilitation efforts.

### **Task 3 – IPP Assistance**

With extensive experience in all facets of this federally-mandated program, we are prepared to provide a variety of IPP-related services when needed by the WPC. Our team is fully knowledgeable in both the state and federal IPP regulations and has longstanding relationships with EGLE staff providing local and statewide oversight.

Our prior experience drafting the City's current sewer use ordinance could be useful in support of efforts to further revise the ordinance, or to work cooperatively with other jurisdictions to update their ordinances. We observe many communities to be challenged by the need for up-to-date interjurisdictional agreements on IPP requirements and administration.

Our general IPP experience could also be useful if the City seeks to revise its headworks loading evaluations for compatible or toxic pollutants. We have worked with EGLE to develop alternate methods for calculating background loads, allowing for less stringent local limits. Fishbeck is experienced and available for other IPP-related activities the City may require; these could include updating the IPP Manual of Procedures, reevaluating extra-strength surcharge rates, and assisting in the City's response to EGLE on an IPP-related enforcement action.

Note: Fishbeck is not currently working for any industrial users of the WPC. While we have previous involvement on a few relatively small environmental projects for General Motors (in Grand Rapids and Lansing) and for Delphi and Country Fresh (in West Michigan), none of these projects would constitute a conflict of interest relative to serving as IPP consultant to the City.

### **Task 4 – Asset Management**

Fishbeck is familiar with the City's Asset Management Plan and the 5-year Project Plan, and is prepared to assist with implementation of this plan either through discussions with EGLE or as a technical advisor for the implementation of the plan. With our prior experience at the City and grant/loan opportunities for other communities in Michigan, this could be a continuation of our previous work with the WPC's Capital Improvement Plan (CIP) and to help implement the City's Asset Management Plan as well as the 5-year Project Plan.

### **Task 5 – Stormwater Management Program**

Fishbeck staff members with extensive familiarity of the Municipal Separate Storm Sewer System (MS4) regulations are available on an as-needed basis to assist with the City's Stormwater Management Program. Such assistance could include preparation for an MS4 compliance audit by developing program updates, reviewing the overall program, or conducting a mock audit. We can also help with future planning, as we continuously maintain an awareness of what is evolving at the state/federal levels. Elements for which our expertise is particularly suitable include:

- Public education plan.
- Illicit discharge elimination program.
- Post-construction stormwater control for new development and redevelopment projects.
- Brownfield sites where contaminated seepage might be problematic inputs to storm sewers.
- Municipal pollution prevention and good housekeeping activities.

### **Other As-Needed Tasks**

We understand, because this contract covers three years, currently unanticipated tasks may appear. Our team, supplemented by additional Fishbeck staff members, has the technical expertise to assist with a wide variety of assignments.

We are able to assist the City with the next RMP compliance audit due no later than July 22, 2022, and the next PSM compliance audit due no later than September 6, 2022.

If an issue arises outside of our expertise, we will work with WPC staff to select and retain an appropriate subconsultant. We will then oversee these subconsultants to ensure an effective, economical resolution for the City.

# PROJECT PORTFOLIO

## COMPREHENSIVE REGULATORY COMPLIANCE ASSISTANCE EXPERIENCE

### COLDWATER BOARD OF PUBLIC UTILITIES

**Contact:** Jon Foley, WWTP Superintendent  
**Address:** 1 Grand Street, Coldwater, MI 49036  
**Phone:** 517.279.9531  
**E-mail:** jfoley@coldwater.org

**Type of Project:** Technical and regulatory assistance: evaluation of local limits, SAL Program, Manual of Procedures, Enforcement Response Plan, Surcharge rate evaluation; industrial user permits development and reviews.

**Project Timeline:** 2017-Present  
**Budget:** \$9,500 per fiscal year

### LAKEWOOD WASTEWATER AUTHORITY

**Contact:** Doug Suntken, Superintendent  
**Address:** 839 Fourth Avenue, Lake Odessa, MI 48849  
**Phone:** 616.374.3265  
**E-mail:** suntkendoug@gmail.com

**Type of Project:** Technical and regulatory assistance: development of local limits, SAL Program, Manual of Procedures, Enforcement Response Plan, Surcharge rate evaluation; industrial user permits development and reviews. Assistance with Mercury PMP, compliance with EGLE IPP PFAS Initiative.

**Project Timeline:** 2014-Present

### CITY OF IONIA

**Contact:** Chris Kenyon, Utilities Director  
**Address:** 720 Wells Street, Ionia, MI 48846  
**Phone:** 616.523.0165  
**E-mail:** CKenyon@ci.ionia.mi.us

**Type of Project:** Technical and regulatory assistance: NPDES permit compliance, reissuance, negotiations with EGLE; assistance with IPP and Mercury PMP; compliance with EGLE IPP PFAS Initiative, other WWTP-related regulatory issues as they arise.

**Project Timeline:** 2004-Present  
**Budget:** \$60,000 annually

### CITY OF KALAMAZOO

**Contact:** Steve Rochow, Environmental Compliance Supervisor  
**Address:** 1415 Harrison Street, Kalamazoo, MI 49007  
**Phone:** 269.337.8365  
**E-mail:** RochowS@kalamazoo.city.org

**Type of Project:** IPP update: reevaluation of local limits, Manual of Procedures SAL Program; assistance with updating basis of design.

**Project Timeline:** 2017-2019  
**Budget:** \$54,000

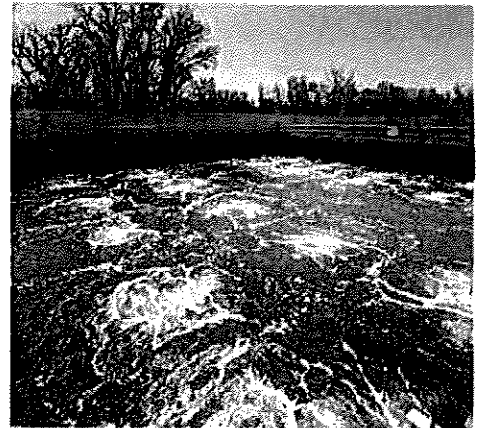
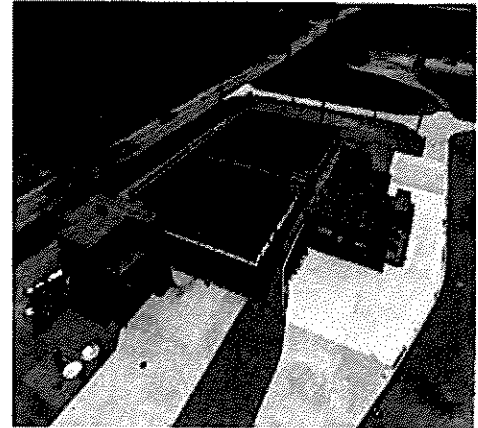

**CITY OF ANN ARBOR**

**Contact:** Keith Sanders, Wastewater Treatment Services Assistant Manager

**Address:** 49 South Dixboro Road, Ann Arbor, MI 48105

**Phone:** 734 794 6450

**E-mail:** ksanders@a2gov.org

**Type of Project:** Technical and regulatory assistance: NPDES permit compliance and negotiations with EGLE, administration of IPP, assistance with Mercury PMP, other WWTP-related regulatory issues as they arise.

**Project Timeline:** 2005-Present

**Budget:** \$24,500 per fiscal year

**CITY OF ST. JOHNS**

**Contact:** Steven M. Martin, Director of Public Services

**Address:** 100 East State Street, Suite 1100, St. Johns, MI 48879

**Phone:** 989-224-8944 ext. 281

**E-mail:** smartin@stjohnsmich.com

**Type of Project:** Development of IPP: local limits, SAL Program, Manual of Procedures, Enforcement Response Plan, surcharge rate evaluation. Administration of IPP: industrial user permits development and reviews. Assistance with compliance with EGLE IPP PFAS Initiative.

**Project Timeline:** 2017-2019

**Budget:** \$60,000



# FLOW MONITORING SERVICES

Fishbeck has the equipment, personnel, and experience to provide the necessary services to develop and implement a flow monitoring program that will help you understand how your system operates under various dry and wet weather conditions. This means you can correct deficiencies in your collection system or plan for future needs with solid baseline data.

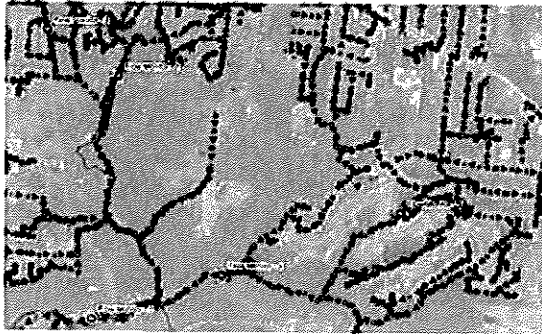

## ASSISTANCE IN SITE SELECTION

Selecting an appropriate site requires understanding the monitoring program goals, as well as experience in determining sites that will yield quality data. Our field technicians and engineers will work with you to identify the most appropriate locations to monitor.

## OUR EQUIPMENT IS READY FOR YOUR PROJECT NOW

We maintain an inventory of various flow monitor types to fit various applications, as well as rain gauges so we can respond to your needs quickly. Delays can cause missed capture of important storm event data.

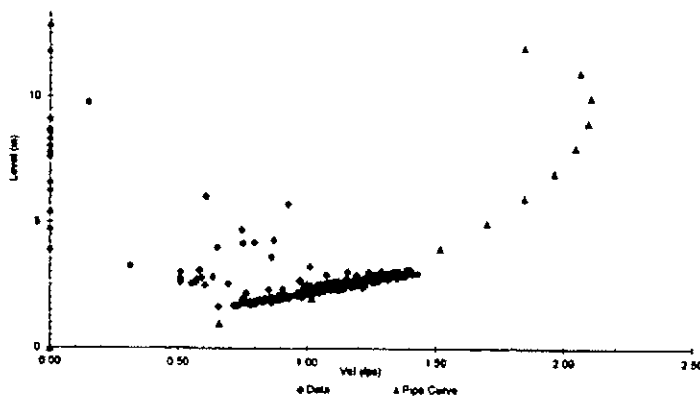

## OUR QA/QC PROCEDURES ENSURE DATA INTEGRITY

Onsite QA/QC procedures allow us to address problems immediately, without having to revisit a site. This minimizes the possibility of lost or unreliable data. Scattergraphs, like the one below, confirm data integrity and can help identify site problems.

800.456.3824 | fishbeck.com

**fishbeck**  
Engineers | Architects | Scientists | Constructors

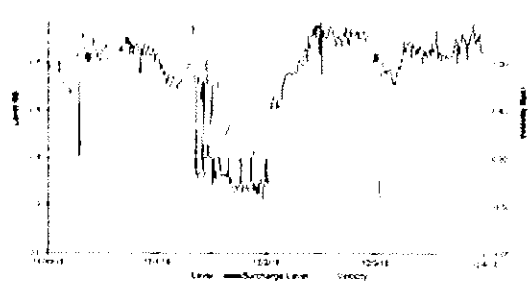

**DATA HANDLING AND ANALYSIS**

Fishbeck uses multiple software applications to provide the most appropriate data handling and analysis. Our monitor download software is used to retrieve data and provide onsite QA/QC. We have developed customized applications to analyze the data and view it in an easy-to-understand format, which helps identify problems in your collection system.

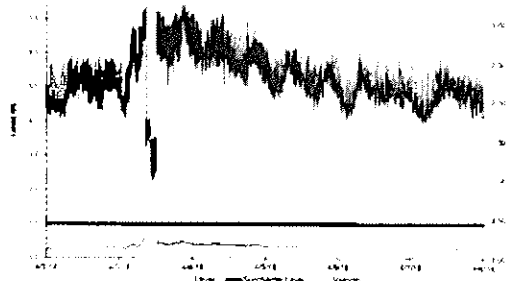

**MODELING CAPABILITIES FOR SYSTEM ANALYSIS**

We use multiple modeling software platforms to analyze collection systems. The choice of software depends on the collection system's characteristics and the output data desired. Our dynamic modeling software can be calibrated to your collection system's performance based on the flow monitoring data and then used to predict future flows or collection system performance during selected rainfall events. This enables you to make logical and cost effective decisions on system upgrades. Our various customized software can be integrated into the analysis to provide the best overall solution to your modeling needs and provide the answers you need.

**EXPERIENCED FIELD TECHNICIANS**

Fishbeck technicians have installed equipment in all pipe sizes and configurations. Customizing the installation is critical to obtaining reliable data.

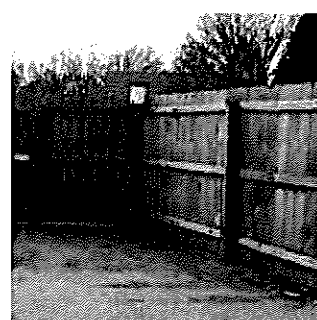

**MODELING CAPABILITIES FOR SYSTEM ANALYSIS**

Our goal is to provide you the flow monitoring services you need at a cost you can afford. This means developing a flow monitoring program that targets specific needs and addresses the problems in your system. We can team with you in a number of ways to make the program work, whether it includes phasing over a period of time or involving you in some of the monitoring activities to reduce costs. In the end, you will gain a better understanding of your collection system performance and be able to correct deficiencies or plan for future growth.

# FLOW MONITORING AND MODELING EXPERIENCE

38 ●

LOCATIONS

## MICHIGAN

11 ½ Mile Relief Drain Drainage District  
Baldwin  
Benton Harbor  
Cedar Springs  
Coldwater  
Ecorse  
Flat Rock  
Flint  
Gibraltar  
Grand Haven  
Grand Ledge  
Grand Rapids  
Jackson  
Lansing  
Lincoln Park  
Macomb Township  
Meridian Township  
Michigan State University  
Monroe  
New Baltimore  
Niles  
Oakland County  
Paw Paw  
Riverview  
South Haven  
Spring Lake  
St. Joseph  
Stephens Relief Drain Drainage District  
Stevensville

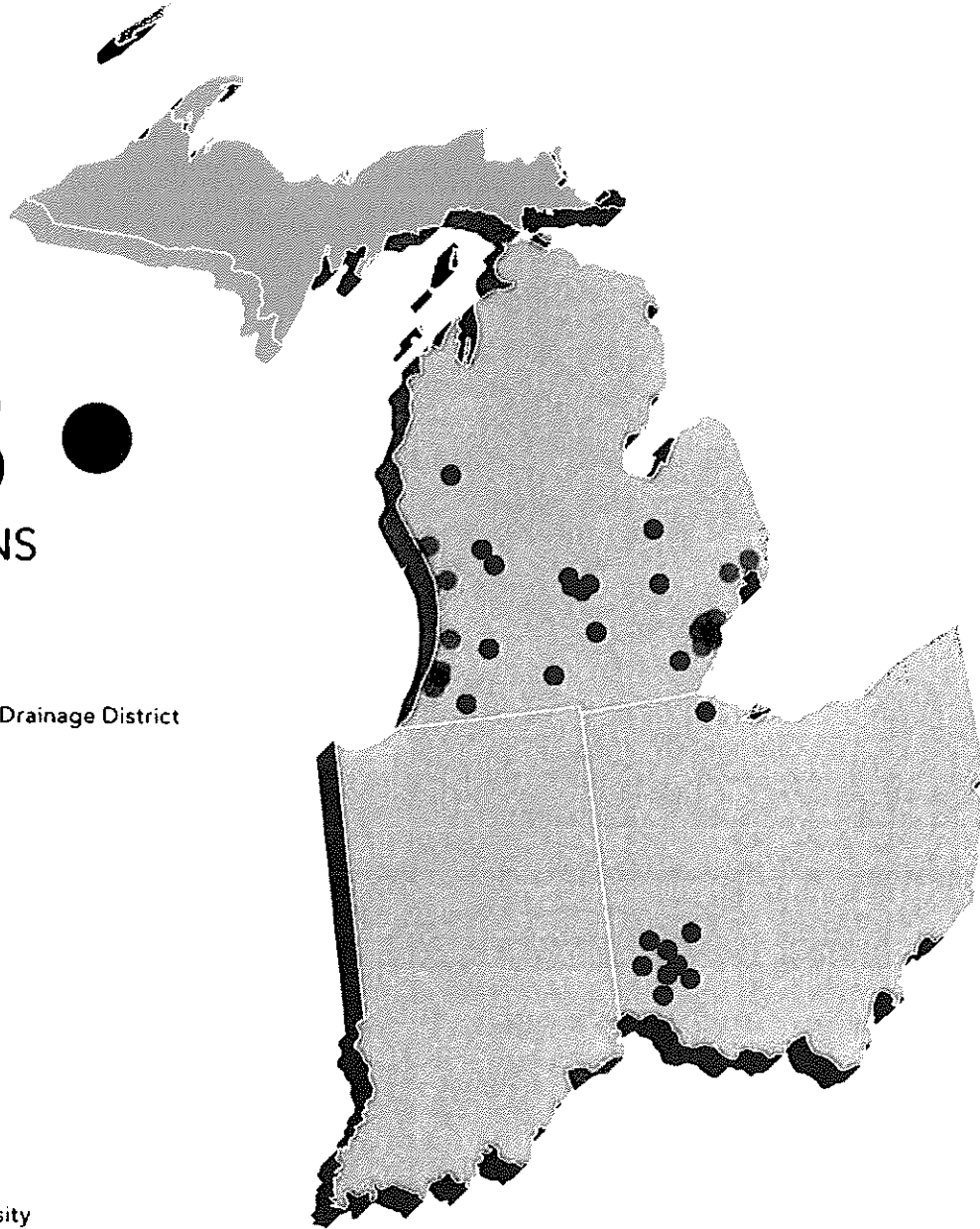

## OHIO

Batavia  
Butler County  
Clermont County  
Fairfield  
Hamilton  
Lebanon  
Lucas County  
Mason  
Metropolitan Sewer District of  
Greater Cincinnati

# GRANT + FUNDING ASSISTANCE

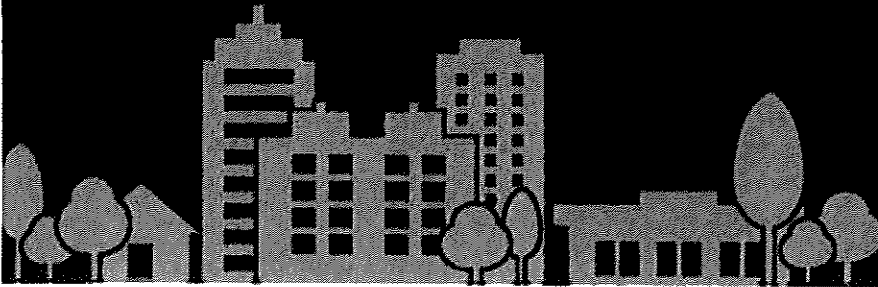

## HOW FISHBECK CAN HELP

Fishbeck has extensive experience working to obtain funding from many sources available for municipal projects. These include grants, low-interest loans, bonds, tax abatements, tax credits, and tax increment financing.

Funding has become a critical consideration in planning the scope and implementation for major municipal projects, but navigating the world of funding can be a daunting task. **Fishbeck's team has the experience you can rely on.**

### WHO'S DOING IT

Fishbeck's team of engineers, architects, and scientists work hand in hand with you to reflect your visions. Our grant specialists offer an additional resource we can bring to the table to get your project off the ground.

### WHAT FISHBECK IS DOING

- ✓ We maintain relationships with funding agencies, keeping up to date with available incentives at the federal, state, and local levels.
- ✓ We maintain subscriptions to resources, such as the Foundation Directory Online and Michigan Grant Watch, allowing our clients access to a wealth of information on grants and grantmakers.
- ✓ We take advantage of training opportunities, enhancing our ability to tell your story in a manner that resonates with grantmakers.

### WHY WE ARE DOING IT

We know funding is important to you, and we know we can help make a difference. Fishbeck has secured millions of dollars in funding for our clients – we would be happy to help you find the funding to make your vision a reality.

### WHEN WE CAN GET INVOLVED



**EARLY ENGAGEMENT** is key to maximizing economic incentives. Before major planning efforts begin, we can help you become grant ready.



**PROJECT DESIGN** is when we can help look for opportunities to fund the efforts of construction.



Creating a **FINANCING STRATEGY** during capital improvement planning and incorporating the funder's priorities in project designs increases a community's chance for success.

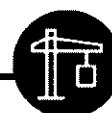

Even **AFTER A PROJECT** has been constructed, there may be opportunities to fund programming or rehabilitation.



#### UTILITIES

USDA, MDARD, EGLE



#### ENVIRONMENT

EPA, EGLE, MEDC



#### TRANSPORTATION

FHWA, MDOT, FTA



#### ECONOMIC DEVELOPMENT

HUD, EPA, MEDC



**BOTTOM LINE:** It is always a good time to think about funding. We are here for you every step of the way.



## Schedule | Cost of Services

Because this is an as-needed contract, individual tasks must have a flexible budget and schedule. The scope, budget, and schedule for each task will be discussed with Ms. Best, or her designee, at the time of the request. Adjustments will then be made, as appropriate, to match the City's needs and available funding. To effectively manage the contract, each task will be assigned a separate project number and invoiced separately. This approach will ensure that, if the full contract budget is not required, the excess funds will not be spent.

Services will be on a time-and-materials basis, using hourly rates in effect when the work is performed. Our current standard rate schedule is enclosed. Direct reimbursable expenses such as company vehicles, special equipment, copying, etc., will be billed at Fishbeck's current rates. Other reimbursable expenses, including outside subcontracted services, will generally be billed at our standard of actual charges plus 10 percent.

Fishbeck will continue to apply the following project management philosophy that has been successfully used for the WPC regulatory assistance contracts, of which the last six were with Fishbeck:

- As each task arises, hold general discussions with Ms. Best, or her designee, regarding the City's goals and objectives.
- Agree on scope, schedule, and budget before proceeding.
- Clearly communicate the City-Fishbeck agreement to a senior project specialist, which is selected based on appropriate experience and expertise. For those situations where specialized services are warranted, we will work with City staff to identify and retain qualified subconsultants.
- Provide an activity report with each invoice to summarize how the City's funds were expended, as demonstrated by the attached report from a recent invoice.
- Periodically follow-up with Ms. Best, or her designee, to ensure the City's goals and objectives are being met.

We have attached figures of the final budget status since fiscal year (FY) 2003, when the City initially retained Fishbeck as the WPC's regulatory consultant. These figures clearly demonstrate how our contract management has consistently responded to the City's needs while maintaining costs at, or below, the allocated budgets.

### Example Activity Report

FTCH PROJECT No. 171961  
FY-2019

INVOICE NUMBER: 389165  
INVOICE DATE: January 7, 2020

**LABOR**

Name	Activity	Hours
Jeff Brown	WW Regulatory Assistance: Day to Day Mgmt of Project teams, technical oversight, and QA/QC	3
Sarah Rutkowski	WW Regulatory Assistance: Coordination with HESCO, meter data review, and invoicing	2.5
Meagan Rea	WW Regulatory Assistance: Processed monthly flow meter and rainfall data	19
Caitlin Wineka	WW Regulatory Assistance: Processed monthly flow meter and rainfall data	3
Doug Dunn	WW Regulatory Assistance: TAPS Site Visit and assistance with Pump improvements	8
Corrinne Haybarker	NPDES Assistance: Phosphorous Recommendations Memo	12.5
Elizabeth Marsh	OSHA PSM Audit: PSM Audit and Binder Preparation	33
Dawn Grates	OSHA PSM Audit: Administrative assistance and QA/QC for PSM Audit	9.5
Susan Kuleck	OSHA PSM Audit: Technical QC for PSM Audit	0.5
Deborah Alderink	OSHA PSM Audit: Technical QC for PSM Audit	1

**REIMBURSABLE EXPENSES**

Name	Activity	Amount
FTCH Internal	Mileage for PSM On-site Review Meeting on 11/6/19-Elizabeth Marsh	\$79.80
FTCH Internal	Mileage for TAPS Site Visit on 11/26/19 - Doug Dunn	\$79.80
HESCO Industrial, LLC	Flow Meter Maintenance/Dessicant Kit	\$160.00
Teledyne Instruments	Flow Meter Battery Boxes	\$3,657.28
Worldwide Express	Postage	\$8.67

**SUBCONTRACTS**

Name	Activity	Amount
	---None---	

Task	Budgeted to Date	Previously Invoiced	Current	Invoiced to Date
2 (Wet Weather Regulatory Assistance)	\$250,000.00	\$201,009.34	\$8,130.25	\$209,139.59
RMP (Risk Management Plan)	\$12,500.00	\$12,479.30	\$0.00	\$12,479.30
OSHA PSM Audit	\$9,900.00	\$1,275.80	\$7,165.80	\$8,441.60
7L (NW PS PUMP RPL PRE DES)	\$6,400.00	\$6,387.30	\$0.00	\$6,387.30
NPDES Asst	\$12,500.00	\$9,457.00	\$1,562.50	\$11,019.50
<i>Subtotal</i>	\$291,300	\$230,608.74	\$16,858.55	\$247,467.29
<i>Authorized</i>	\$300,000			\$300,000.00
<i>Remaining</i>	\$8,700 3%			\$52,532.71 18%

**Final Budget Performance, 2018 - 2020**

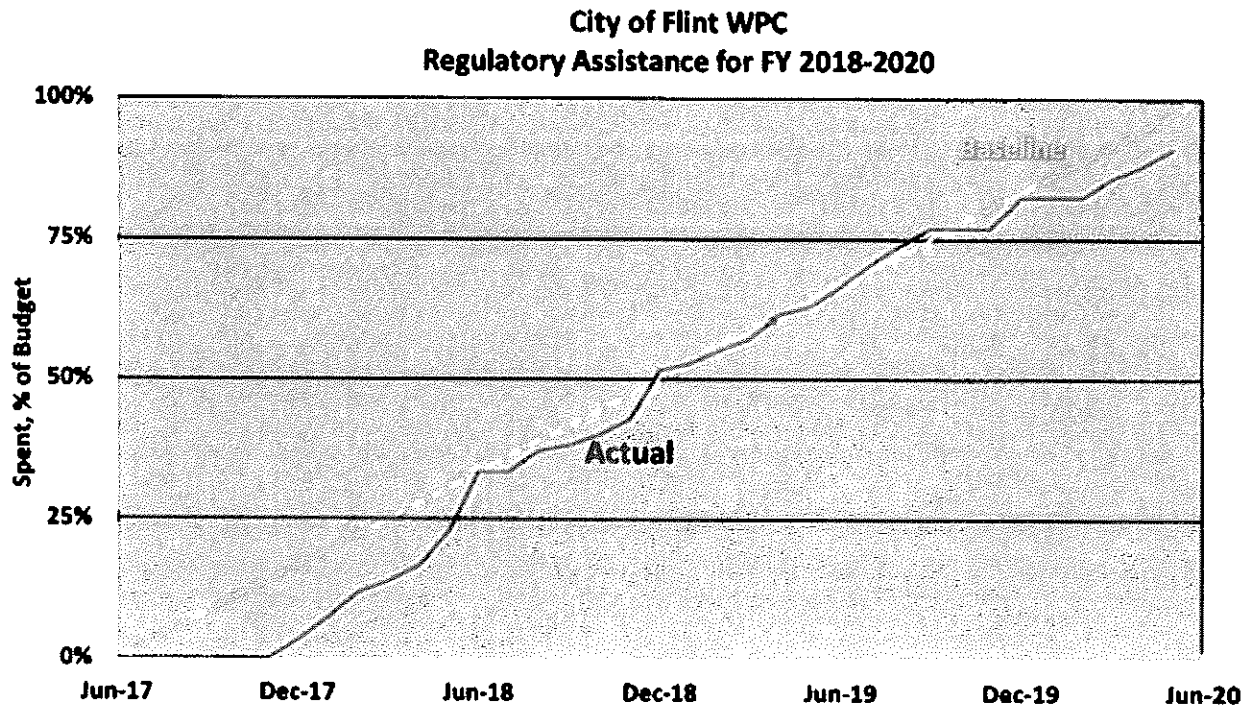

**Final Budget Performance, 2003 - 2017**

FY2015 - 2017

FY2012-FY2014

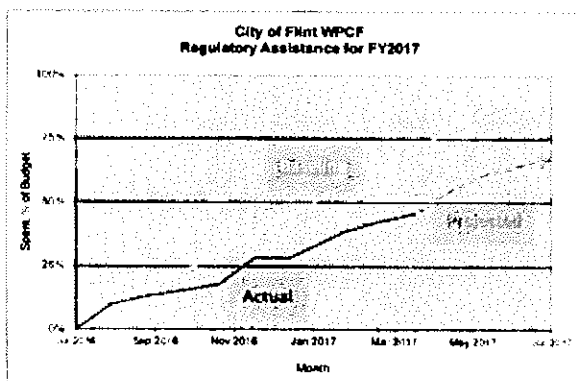

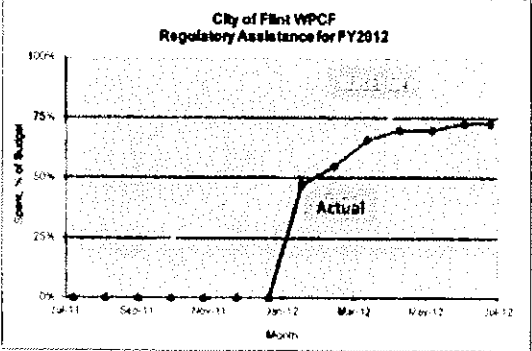
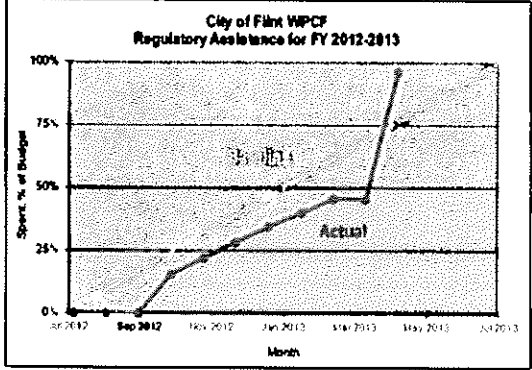
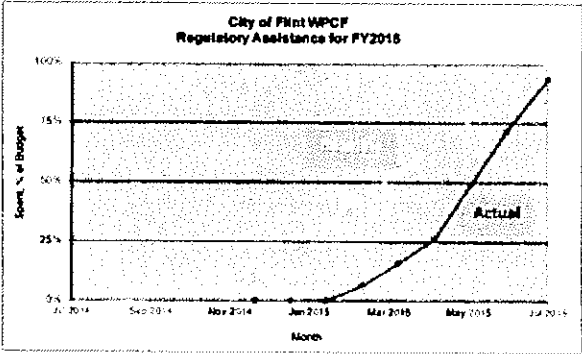
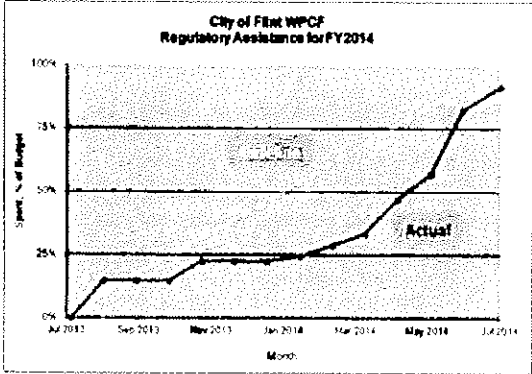
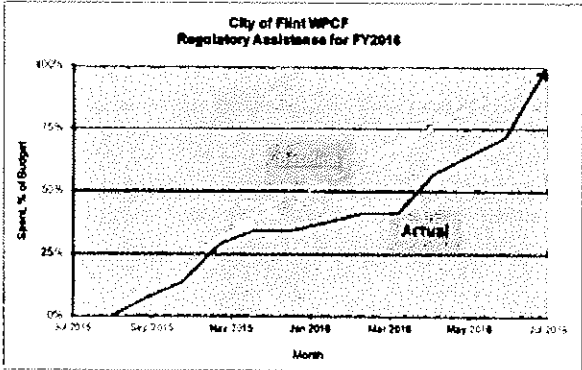



FY2009-FY2011

FY2006-FY2008

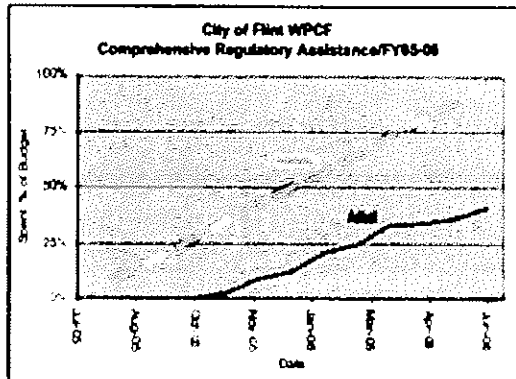
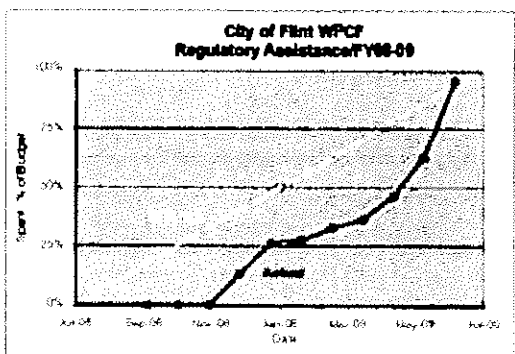
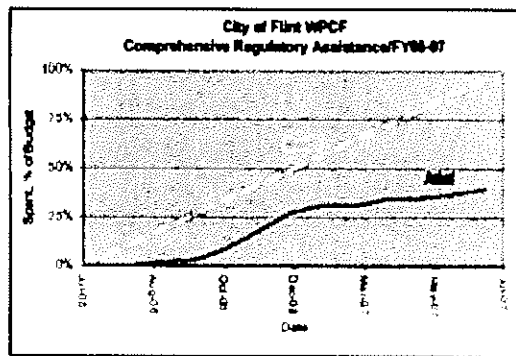
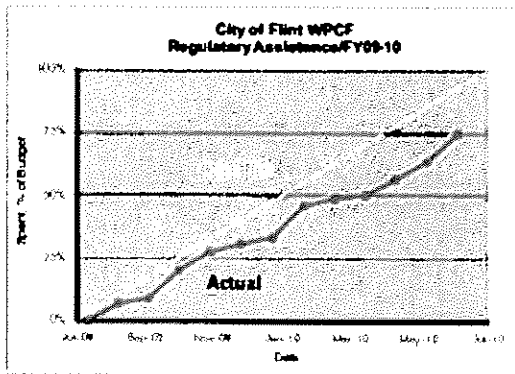
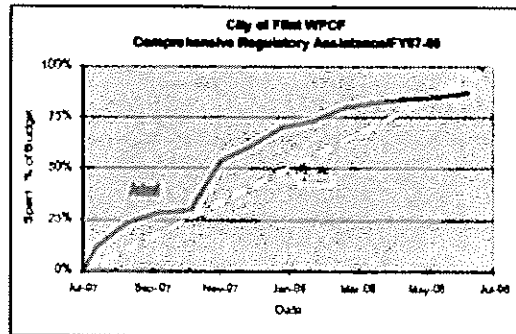
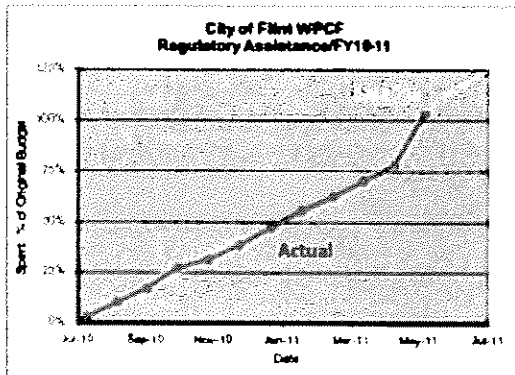

FY2003-FY2005

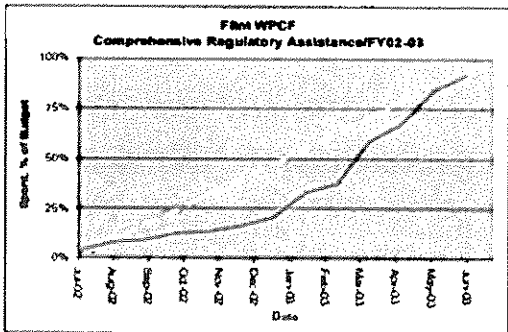
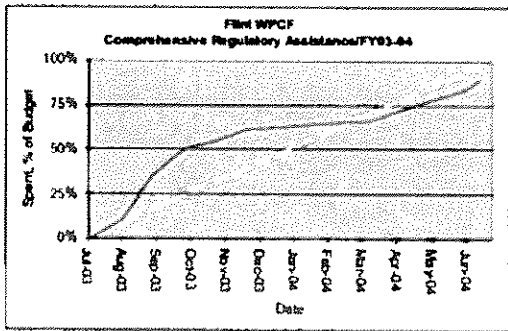
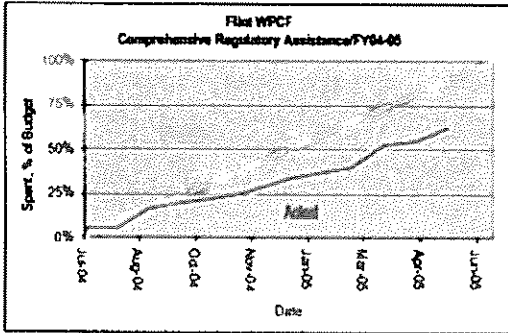

## Rate Schedule

June 13, 2020

Principal		\$243
Architect   Construction Engineer/Manager/Administrator   Engineer   Estimator   Geologist   Hydrogeologist   Industrial Hygienist   Interior Designer   Project Manager   Scientist   Surveyor	Senior Level	\$135-\$235
	Mid Level	\$122-\$135
	Staff Level	\$79-\$122
Architectural Specialist   Engineering Specialist   Environmental Specialist   Health & Safety Specialist   Operations Specialist   Technical Specialist   Project Superintendent   Survey Specialist	Senior Level	\$141-\$212
	Mid Level	\$101-\$141
	Staff Level	\$79-\$101
Technician	Senior Level	\$110-\$128
	Mid Level	\$93-\$110
	Staff Level	\$70-\$93
Production Support		\$82
Photocopies	\$0.10/Copy	
Mileage/Passenger Vehicles	\$0.70/Mile	
Field and Service Vehicles	\$0.95/Mile (\$37/day min.)	
Equipment Schedule	Separate Schedule	
Expenses and Outside Services	Cost Plus 10%	

Compensation to be at one and one-half times the hourly rate for approved overtime.

Invoices are rendered every four weeks and payment is due upon receipt. A service charge of 1% per four-week period is added to accounts unpaid after 28 days from date of billing.

## Project Team

Because of the variable scope of this contract, Fishbeck proposes a team consisting of a principal in charge, project manager, and senior project specialists to lead specific tasks on an as-needed basis. These specialists were selected to provide the experience and technical expertise to ensure tasks are completed in line with the City's goals and objectives. Additional members of our technical and clerical staff will provide supplemental assistance as necessary on a task-by-task basis.

Further details of this team are highlighted below, with resumes enclosed for your review:

### Principal-in-Charge / Project Manager

Mr. Jeffrey J. (Jeff) Brown, PE will serve as project manager and the City's primary interface for contract activities. Mr. Brown has over 25 years of consulting experience, specializing in helping local communities plan their wastewater systems. He has led the City's flow monitoring program from its inception and been involved with a variety of projects for the City of Flint WPC, including serving as project manager for the last regulatory assistance contract between Fishbeck and the City (2017-2020).

### Fishbeck Senior Project Specialists

#### Task 1 – NPDES Permit Negotiation and Support

Ms. Corrine Haybarker will lead the Fishbeck team in addressing general NPDES permit compliance issues. Ms. Haybarker has over 14 years of experience providing consulting services on a variety of municipal and industrial wastewater, water, and air projects, with a current focus on municipal and industrial wastewater regulatory compliance. Her previous experience with the City's permit includes assisting with EGLE negotiations for permit renewals. Most recently Ms. Haybarker assisted with EGLE negotiations for the WPC phosphorus effluent limit, which included a technical review of the EGLE water quality survey. Ms. Haybarker also has extensive experience with NPDES permitting for other municipal facilities in Michigan.

#### Task 2 – Wet Weather Management

Ms. Sarah Rutkowski, PE will lead the Fishbeck team addressing NPDES requirements that the City's facilities must be adequate to treat all dry and wet weather flows resulting from up to a 25-year/24-hour storm. Ms. Rutkowski has been involved with the City's regulatory compliance program for the past four years and understands the history of the system and goals of the program moving forward. She is currently assisting the City with its ongoing NPDES permit negotiations pertaining to wet weather compliance. She will be responsible for continuing the ongoing flow monitoring, model development, and data analysis. Ms. Rutkowski will lead efforts to refine the City's plan to reduce/manage the flows and identify work to be completed in the collection system. She understands the need to develop a cost-effective plan to abate, or at least manage, the excess flows. Ms. Rutkowski has extensive experience in the flow monitoring and hydraulic modeling of wastewater collection systems for numerous municipalities across the state.

#### Task 3 – Industrial Pretreatment Program (IPP) Assistance

Ms. Haybarker will also lead the Fishbeck team assisting WPC staff with the City's IPP. Having worked with this program for the past four years, she has valuable knowledge of current policies and procedures. She has also conducted headworks loading evaluations used to develop the compatible and toxic pollutant local limits, assisted with drafting new sewer use ordinances, assisted with industrial user permit development, and supported enforcement response activities for many municipal facilities in Michigan.

#### **Task 4 – Asset Management**

Mr. Joshua W. (Josh) Redner, PE will lead the Fishbeck team to address the City's infrastructure and asset management needs. Mr. Redner has over 11 years of experience helping municipal and industrial clients find solutions to their wastewater treatment issues. Mr. Redner is very familiar with the WPC, having been involved with the grit system evaluation and the Northwest Pump Station evaluation. Mr. Redner worked extensively with Mr. John C. (Jack) Rafter, PE and has acquired much of the working knowledge that Mr. Rafter gained during his 12 years assisting the City of Flint. Mr. Redner is well-versed in EGLE's asset management requirements and SRF program requirements, and he has the expertise to help the City implement the 5-year Project Plan. He has extensive experience evaluating, cost estimating, prioritizing, facilities planning, and obtaining grants/loans for wastewater systems across Michigan. Mr. Redner was named 2012 New Professional of the Year by the Michigan Water Environment Association.

Mrs. Danielle N. Yoon, PE will provide grant and funding assistance. Mrs. Yoon leads grant writing efforts for Fishbeck, utilizing capital improvement plans and other master level planning documents to develop funding strategies for clients. She has worked closely with various regulatory agencies and communities to develop and submit numerous grant and loan applications at both the state and federal level; successful applications have secured more than \$28 M grant and \$4 M loan dollars to date.

#### **Task 5 – Storm Water Management Program**

Ms. Rutkowski will also lead the Fishbeck team providing as-needed assistance with the MS4 Storm Water Permit. With knowledge of the City's sewer systems, she will provide as-needed assistance with pollution prevention, public education, illicit connection elimination, and MS4 permit compliance.

#### **Task 6 – Other Regulatory Support**

Elizabeth (Liz) A. Marsh, PE, CHMM will support environmental, health, and safety (EHS) compliance. Liz is a Senior Environmental Engineer in Fishbeck's Novi office and has over 25 years of environmental experience as a consultant specializing in regulatory compliance. She has previously assisted the City with its RMP and PSM programs.

### **Subconsultants**

We also offer potential subconsultants available to the City through the Fishbeck team. The advantage of such an approach is demonstrated by the following subconsultants that have provided key roles in the last three Fishbeck Comprehensive Regulatory Assistance contracts with the City:

- HESCO Services can provide as-needed installation, maintenance, and data collection of the City's sewer flow monitoring equipment. They are well-known across Michigan for technical expertise, reliability, accuracy, and completeness. Our contact at HESCO, Mr. Kevin Livingston, is the president and has been working with Fishbeck and the City on sewer metering associated with the SWMM model and the Collection System and Treatment Facility Capacity Analysis.

Subconsultants who have been involved in a lesser extent in the last four regulatory assistance contracts are also available on an as-needed basis to the City through the Fishbeck team. These include Cecil Lue-Hing & Associates, Inc.; Hinshon Environmental Consulting; Industrial Furnace Company; and Sigma Consulting, Inc. Other subconsultants selected in cooperation with the City may also be retained, where appropriate, to address a particular issue.

# ORGANIZATIONAL CHART

## CITY OF FLINT – 3-YEAR COMPREHENSIVE REGULATORY COMPLIANCE ASSISTANCE

### CITY OF FLINT

PRINCIPAL-IN-CHARGE  
PROJECT MANAGER  
**\*Jeff Brown, PE**

**TASK 1**  
NPDES PERMIT  
NEGOTIATION AND  
SUPPORT

**\*Corrine Haybarker**  
Dave Filipiak, CHMM

**TASK 2**  
WET WEATHER  
MANAGEMENT

**\*Sarah Rutkowski, PE**  
Caitlin Wineka  
Chuck Carr  
Haley Miller

**TASK 3**  
IPP ASSISTANCE

**\*Corrine Haybarker**  
Dave Filipiak, CHMM

**TASK 4**  
ASSET MANAGEMENT

**\*Josh Redner, PE**  
Erin Szczegielniak, PE  
Andy Austin, PE  
Deann Falkowski, PE  
Danielle Yoon, PE

**TASK 5**  
STORMWATER MANAGEMENT  
PROGRAM

**\*Sarah Rutkowski, PE**  
Brian McKissen, PE, CFM

**OTHER**

**\*Liz Marsh, PE, CHMM**

**GIS**

Michelle Lazar, PE, GISP

\* Key staff, resume included.



## **JEFF BROWN, PE**

**SENIOR VICE PRESIDENT | PRINCIPAL**

Jeff is an experienced civil engineering project manager. His areas of concentration include general municipal engineering, utility master planning, drainage/ stormwater management, utility improvements, water systems, pumping stations, and sanitary sewers.

## **EXPERIENCE**

### **WASTEWATER COLLECTION**

#### **CITY OF FLINT, MICHIGAN SWMM MODEL**

Developed a plan to meet MDEQ requirements for available retention basin capacity at the WPCF. The project included flow monitoring and hydraulic modeling.

#### **CITY OF LANSING, MICHIGAN WET WEATHER CONTROL PLAN**

Project manager for the second phase of the wet weather control plan. The plan includes an overall system model update based on flow metering at over 60 locations, CSO improvements, pump station improvements, and a comprehensive plan to address CSO/SSO issues over the next 20 years.

#### **CLIPPERT STREET**

Project engineer for preliminary design of a 120-cfs stormwater pumping station.

#### **HARTON STREET**

Project engineer for design of a 150-cfs stormwater pumping station.

#### **OKEMOS ROAD**

Project manager for design of a 1,200-gpm sanitary sewer pumping station to serve the Jackson National Life development.

#### **NORTH ALAIEDON PUMP STATION**

Project manager for design of a 1,400-gpm dry pit/wet pit sanding pump station to serve underdeveloped commercial/ industrial areas.

#### **ALAIEDON TOWNSHIP TRUNK SEWER**

Project manager for design of approximately seven miles of sanitary sewer force main.

#### **NORTH PLANT**

Project engineer for a study to evaluate operation of the equipment in the influent structure along with condition of the surface concrete and several miscellaneous improvements.

#### **CSO WWTP IMPROVEMENTS**

Project engineer for predesign for improvements at the WWTP including the equalization basin flushing system and pump replacements.

#### **COLDWATER BPU, MICHIGAN SOUTH ANGOLA ROAD UTILITY STUDY**

Project manager for a study to determine the necessary utility improvements to serve the area along Angola Road south of the city limits.

#### **EAST END SANITARY SEWER STUDY**

Project manager for a study to determine if the City's system had capacity for a proposed development.

### **YEARS OF EXPERIENCE**

17 years — Fishbeck

27 years — total

### **EDUCATION**

BS in Civil Engineering, Michigan State University

### **REGISTRATIONS/ CERTIFICATIONS**

Professional Engineer - Michigan

### **MEMBERSHIPS**

Michigan Water Environment Association

SS Member (Select Society of Sanitary Sludge Shovelers)

Water Environment Federation

Water Environment Association, Ohio

### **AWARDS**

2013 MWEA Collections Systems Engineer of the Year



**JEFF BROWN, PE**  
**SENIOR VICE PRESIDENT |**  
**PRINCIPAL**

**SSES**

Project manager for an SSES to identify infiltration sources as part of an SRF project including flow monitoring, hydraulic modeling, manhole inspections, television inspection, and dye testing.

**WILLOWBROOK PUMP STATION**

Project manager the Willowbrook pump station upgrade design.

**WASHINGTON AND SPRAGUE STREET SANITARY SEWER IMPROVEMENTS**

Project manager for design of improvements, including CIPP lining, sewer replacement, and manhole rehabilitation.

**2010 MANHOLE AND SEWER LINING**

Project manager for design.

**JAY STREET CIPP**

Project manager for design.

**CITY OF LINCOLN PARK, MICHIGAN**  
**SRF PROJECT PLAN**

Project manager responsible for preparing an SRF project plan that included smoke testing, flow monitoring, hydraulic modeling and preparation of a collection system map in GIS.

**CITY OF NILES, MICHIGAN**

**SSES**

Project manager responsible for completing an SSES for the City as part of an SRF project.

**CITY OF ESSEXVILLE, MICHIGAN**

**HYDRAULIC STUDY**

Project manager responsible for a hydraulic study to determine if the City was in compliance with their current CSO program.

**CLERMONT COUNTY WATER RESOURCES DEPARTMENT | BATAVIA, OHIO**  
**NINE MILE COLLECTION IMPROVEMENTS**

Performed QA/QC for the evaluation of collection system improvements upstream of the Nine Mile WWTP. The evaluation including flow monitoring at six locations that was used to calibrate the County's hydraulic model. The evaluation looked at existing and future flows along with several alternatives for eliminating a capacity restriction in the system.

**LOCUST LAKE LIFT STATION**

Using the existing wet well, this project involved total replacement of the Locust Lake lift station and pump building to eliminate near constant bypass pumping during wet weather events. Performed QA/QC.

**CITY OF GRAND LEDGE, MICHIGAN**  
**SANITARY SEWER MASTER PLAN**

Project manager for preparation of the City's collection and treatment system master plan. Addressing wet weather issues with cost effective solutions was a primary concern. Work included an SSES and application for SRF funding.

**WEST JEFFERSON PUMP STATION**

Project manager for upgrade design for the existing 50-foot-deep pump station.

**CITY OF WILLIAMSTON, MICHIGAN**  
**SANITARY SEWER MASTER PLAN**

Project manager for a collection system master plan to determine the available capacity of the City's system. The City's primary concern was the effect of RDII on the system and preparing an SSES plan to maximize effectiveness.

**VICTORY MEADOWS/LINN ROAD SANITARY SEWER IMPROVEMENTS**

Project manager for design of two suction lift pumping stations to serve two proposed developments and surrounding areas.





## **CORRINE HAYBARKER**

### **ENVIRONMENTAL ENGINEER**

Corrine is an environmental engineer with 14 years of experience providing consulting services on a variety of water, air, industrial, and municipal wastewater engineering projects. Her professional experience includes process design and coordinating environmental compliance issues for a variety of industries and municipalities. Corrine is currently focused on industrial and municipal regulatory compliance.

## **EXPERIENCE**

### **WASTEWATER PROCESS**

#### **IPP ACTIVITIES**

Project engineer responsible for discharge evaluations, headworks loading studies, advanced allocation strategy implementation, procedures manual development, enforcement action support, and/or Michigan approval agency interface for numerous municipal clients

- City of Kalamazoo, Michigan
- City of Lapeer, Michigan
- City of Litchfield, Michigan
- City of Charlotte, Michigan
- City of Wyoming, Michigan
- City of St. Johns, Michigan
- City of Owosso, Michigan
- Delta Charter Township, Michigan
- Coldwater Board of Public Utilities, Michigan
- Lakewood Wastewater Authority, Michigan
- City of Ann Arbor, Michigan

Prepared IPP permit compliance Industrial User Discharge Reports for industrial users

- Woodward; Fort Collins and Loveland, Colorado
- Hewlett Packard, Fort Collins, Colorado
- WaterPik; Fort Collins, Colorado
- Whip Mix, Fort Collins, Colorado
- Florida Cir Tech, Greeley, Colorado
- Colorado Premium, Greeley, Colorado
- APW Wyott, Cheyenne, Wyoming
- Avago Technologies, Fort Collins, Colorado

#### **NPDES PERMITTING ACTIVITIES**

Engineer responsible for activities such as renewal applications and assistance with Michigan approval agency negotiations for municipal clients.

- City of Flint, Michigan
- City of St. Johns, Michigan
- City of Litchfield, Michigan
- City of New Baltimore, Michigan
- City of Petoskey, Michigan
- City of Holland, Michigan
- City of Ionia, Michigan

#### **MERCURY MINIMIZATION**

Project engineer responsible for assistance in planning and implementing mercury minimization programs for municipal wastewater treatment facilities. These efforts have included programmed sampling, user surveys, source identification studies, sewer use ordinance modifications, and/or enforcement assistance for various municipal clients.

#### **YEARS OF EXPERIENCE**

4 years — Fishbeck

14 years — total

#### **EDUCATION**

BS in Environmental Engineering  
Colorado State University

#### **REGISTRATIONS/ CERTIFICATIONS**

Engineer in Training



**CORRINE  
HAYBARKER**  
ENVIRONMENTAL ENGINEER

- City of Ann Arbor, Michigan
- City of Grand Ledge, Michigan
- City of Ionia, Michigan
- City of Ithaca, Michigan
- City of Bad Axe, Michigan

**SADDLER RIDGE METROPOLITAN DISTRICT | SEVERANCE, COLORADO**

Project engineer for the process design and detailed design drawings and specifications for a municipal MBR water reclamation facility and influent sewer.

**VILLAGE OF ST. PARIS, OHIO**

Project engineer for WWTP influent fine screen and building design, specifications, and contract documents.

**CITY OF COLUMBUS, OHIO**

Analyzed and reported on flow monitoring and field inspection data to quantify private inflow and infiltration rates from individual houses and sub-basins in the project area.

**PORT COLUMBUS INTERNATIONAL AIRPORT | COLUMBUS, OHIO**

Project engineer responsible for design of a glycol collection system diversion valve vault.

**STORMWATER**

**CITY OF COLUMBUS, OHIO**

**REGULATORY ASSISTANCE**

- Developed select sections of the stormwater management plan (SWMP).
- Collected wet weather stormwater samples in accordance with NPDES stormwater permit.
- Analyzed and reported on rainfall data, flow results, and water quality results.

**INFLOW/INFILTRATION STUDY**

Analyzed and reported on flow monitoring and field inspection data to quantify private inflow and infiltration rates from individual houses and sub-basins in the project area.

**ENVIRONMENTAL MANAGEMENT SERVICES**

**WESTWATER FARMS PRODUCED WATER TREATMENT FACILITY | WESTWATER, UTAH**

Project engineer responsible the development of a UPDES permit application for a natural gas production water recycling facility.

**GOLDEN BUFFS HOTEL | BOULDER, COLORADO**

Project engineer responsible for the development and submittal of a discharge permit application for groundwater resulting from construction of a new hotel.

**STERLING ETHANOL | STERLING, COLORADO**

Project engineer responsible for the development and submittal of an industrial individual wastewater discharge permit for an ethanol production facility.

**ROYAL GORGE BRIDGE AND PARK | CANON CITY, COLORADO**

- Project engineer responsible for the development and submittal of the site applications for the WTP and WWTP.
- Project engineer responsible for the development and submittal of the preliminary effluent limit application for the WWTP.

**AIR REGULATORY ASSISTANCE**

**WESTWATER FARMS PRODUCED WATER TREATMENT FACILITY | WESTWATER, UTAH**

Project engineer responsible for air emission calculations and permit application submittal for a natural gas production water recycling facility.



**SARAH RUTKOWSKI, PE**  
**SENIOR WATER & WASTEWATER ENGINEER**

Sarah is a project engineer involved in planning and analysis of wastewater, stormwater, and water distribution systems. She specializes in the wastewater flow monitoring studies for I/I programs and the hydrologic/hydraulic analysis of collection systems in InfoWorks ICM, EPA SWMM, and XP SWMM modeling software.

**EXPERIENCE**

**WASTEWATER COLLECTION**

**YEARS OF EXPERIENCE**

5 years — Fishbeck  
8 years — total

**EDUCATION**

MS in Agricultural and Biological Engineering, Purdue University

BS in Agricultural and Biological Engineering, Purdue University

**REGISTRATIONS/  
CERTIFICATIONS**

Professional Engineer - Michigan

Envision Sustainability Professional

**MEMBERSHIPS**

American Society of Civil Engineers

Michigan Water Environment Association

**CITY OF FLINT, MICHIGAN  
FLOW MONITORING AND HYDRAULIC MODELING**

Project Engineer providing support to the City's sanitary sewer flow metering and hydraulic modeling program. Tasks include monthly review and analysis of the City's flow monitoring data. Analyzed data to determine areas most prone to inflow and infiltration, recommend areas for future sewer rehabilitation, and evaluation of flow reductions following improvement projects throughout the service area

Performed a recalibration of the City's hydraulic model in 2017/2018 to assess compliance with the 25-Year 24 hour remedial design storm and provided guidance to the City on wet weather regulatory compliance. Also provided hydraulic model analysis to support other projects and initiatives proposed by the City.

**GREAT LAKES WATER AUTHORITY, MICHIGAN  
COMPREHENSIVE REGIONAL WASTEWATER MASTER PLAN**

GLWA formed in 2015 to provide water and wastewater service to the greater Detroit Regional System. In 2017, GLWA initiated a comprehensive wastewater master plan. Tasks under the project include First Tier customer outreach and coordination, collection and analysis of customer service area characteristics, contract capacity review, regulatory compliance, and MS-4/illicit discharge information to support the Authority's future decision making.

**MACOMB COUNTY PUBLIC WORKS OFFICE, MICHIGAN  
8 1/2 MILE RELIEF DRAIN DRAINAGE DISTRICT WASTEWATER ASSET MANAGEMENT PROGRAM**

- Completed a green infrastructure study for the drainage district. Selected feasible BMP options for the drainage district based on land use and soil type and analyzed the effectiveness to reduce peak runoff and volume to the Chapaton RTB using the existing XP-SWMM hydraulic model. The outcome of the project was a stormwater reduction scoping tool to use in evaluating potential stormwater reduction for future green infrastructure projects.
- Assisted with horizontal asset inventory, condition assessments, and criticality
- Developed work order forms and maintenance calendar for Chapaton RTB vertical assets

**MACOMB INTERCEPTOR DRAIN DRAINAGE DISTRICT WASTEWATER MASTER PLAN**

A wastewater master plan is currently being developed for the Macomb Interceptor Drain Drainage District (MIDDD) through the year 2045. Project role included performing a recalibration of the existing MIDDD model hydrology for each customer billing meter. A future conditions model was also developed using estimates of projected sewerage areas and populations. The existing and future conditions models were used to analyze improvement alternatives to accommodate the current and future MIDDD customers through the year 2045.



**SARAH  
RUTKOWSKI, PE  
WATER & WASTEWATER  
ENGINEER**

**8 ½ MILE RELIEF DRAIN DRAINAGE DISTRICT - SRF PROJECT PLAN**

Developed SRF Project Plan in 2019 for the District on behalf of the Macomb County Public Works Office. Proposed projects include control measures to reduce the frequency and volume of partially treated combined sewer overflows from the Chapaton Retention Treatment Basin (RTB) into Lake St. Clair, including expansion of the Chapaton RTB and addition of in-system storage control structures in the 8 ½ Mile Drain. The SRF funding requested for both projects is \$30.3 million.

**CITY OF LANSING, MICHIGAN  
HYDRAULIC MODEL CAPACITY STUDIES**

Reviewed and updated the City's InfoWorks ICM hydraulic model to assess sewer capacity for proposed commercial and residential developments. Provided recommendations for handling the additional flow based on modeling results.

**METROPOLITAN SEWER DISTRICT OF GREATER CINCINNATI, OHIO  
I/I PROGRAM SUPPORT**

Analyzed sewer system flow meter data for quarterly reports. Calculated dry weather and wet weather flow metrics in EPA SSOAP Toolbox from over 100 meter locations in the system for the quarterly flow monitoring program. Ranked sanitary sewer districts using available GIS data to recommend the highest priority areas for rehabilitation projects. Assembled cost estimates for maintenance packages.

**CITY OF RIVERVIEW, MICHIGAN  
WASTEWATER SAW ASSET MANAGEMENT PROGRAM**

Developed, calibrated, and analyzed a sanitary sewer hydraulic model in XP-SWMM software. Assessed model results from the historic August 11, 2014, rainfall event and the 25-year, 24-hour storm to evaluate capacity and potential hydraulic restrictions within the collection system. Project also included a planning level design of Lift Station improvements and storage basin for area with high I/I.

**CITY OF FLAT ROCK, MICHIGAN  
WASTEWATER SAW ASSET MANAGEMENT PROGRAM**

Collected and analyzed flow data for 10 meters within the sanitary sewer network. Calculated flow metrics and compared the data against USEPA standards for dry and wet weather I/I. Recommended projects in the highest priority districts for the capital improvement plan.

**CITY OF GIBRALTAR, MICHIGAN  
WASTEWATER SAW ASSET MANAGEMENT PROGRAM**

Analyzed and collected flow data for meters within the sanitary sewer network. Calculated flow metrics and compared the data against USEPA standards for dry and wet weather I/I. Recommended projects in the highest priority districts for the capital improvement plan.

**STORMWATER**

**OAKLAND COUNTY WATER RESOURCES COMMISSIONER, MICHIGAN  
MINNOW POND DRAIN - HALSTED ROAD DRAIN CROSSING STUDY**

Prepared HEC-RAS hydraulic model to analyze Minnow Pond Drain at Halsted Road under existing conditions and with proposed improvements. The road is frequently closed due to flooding. Prepared USACE/MDEQ joint permit application to complete construction activities.

**WASHTENAW COUNTY WATER RESOURCES COMMISSIONER, MICHIGAN  
JJ KNAPP DRAIN HYDRAULIC ASSESSMENT AND CULVERT REPLACEMENT**

Prepared HEC-RAS hydraulic model of the J.J. Knapp Drain at two road crossings and completed the engineering design for culvert replacement and stream rehabilitation. The crossings at both locations have exceeded their useful life and one crossing is permanently closed for safety reasons. The study and resulting design improves the hydraulic capacity from existing conditions.



## **JOSH REDNER, PE**

### **SENIOR WATER & WASTEWATER ENGINEER**

Josh is a design engineer and technical consultant on municipal and industrial wastewater treatment projects. He has specific experience in the planning, design, and implementation phases for mechanical, biological, and chemical treatment systems and asset management and wastewater regulations.

## **EXPERIENCE**

### **STUDIES**

#### **CITY OF FLINT, MICHIGAN**

Project engineer for a study to right-size an existing main sanitary lift station and provide wet weather pumping capacity.

#### **CITY OF ST. JOHNS, MICHIGAN**

Project manager and engineer for WWTP facility master plan that established a pathway to implement approximately \$23 million of improvements over 15 years.

#### **CITY OF REED CITY, MICHIGAN**

Project manager and engineer for planning phase of WWTP improvements that will upgrade aging facilities. Construction expected to begin in 2021.

#### **CITY OF COLDWATER, MICHIGAN**

Project manager and engineer for WWTP asset management master plan and ongoing treatment improvements investigation.

#### **CITY OF NILES, MICHIGAN**

Project engineer for WWTP asset management master planning. Anticipated improvements include grit removal, influent sanitary screening, wet weather flow improvements, and disinfection improvements.

#### **CITY OF GRANDVILLE, MICHIGAN**

Helped the City identify I/I sources throughout their collection system. Study included extensive flow monitoring, televising, smoke testing, and field observations.

#### **VILLAGE OF CALEDONIA, MICHIGAN**

Prepared a feasibility study to identify option for continued sanitary sewer service. Study used a triple bottom line approach to identify the long-term recommended alternative.

#### **CITY OF HUDSON, MICHIGAN**

Helped the City with the planning phase of WWTP and collection system improvements by preparing a Michigan SRF Project Plan. This report helped the City secure SRF financing for system improvements.

## **ASSET MANAGEMENT/O&M**

Helped various communities evaluate the existing condition of collection system and WWTP assets to develop capital improvements plans that address the short- and long-term needs of their facilities.

- Village of Bellaire, Michigan
- City of Grandville, Michigan

### **YEARS OF EXPERIENCE**

3 years — Fishbeck

11 years — total

### **EDUCATION**

BS in Civil and Environmental Engineering, University of Michigan

### **REGISTRATIONS/ CERTIFICATIONS**

Professional Engineer - Michigan

### **MEMBERSHIPS**

Michigan Water Environment Association

Water Environment Federation

### **AWARDS**

2012 New Professional of the Year, Michigan Water Environment Association

2019 Kenneth J. Miller Founders' Award, Michigan Water Environment Association



**JOSH REDNER, PE**  
**SENIOR WATER &**  
**WASTEWATER ENGINEER**

- City of Belding, Michigan
- Village of Baldwin, Michigan
- Lakewood Wastewater Authority, Lake Odessa, Michigan

## **REGULATORY ASSISTANCE**

### **JACK BROWN PRODUCE, LLC | SPARTA, MICHIGAN**

Helped negotiate a new NPDES permit for this apple processing facility, including flow monitoring and waste characterization study.

## **WATER & WASTEWATER PROCESS**

### **CITY OF LUDINGTON, MICHIGAN**

Project manager and design engineer for the design and construction of wastewater system pump station improvements, screening and grit removal, extended aeration biological treatment system, biosolids storage facility, and disinfection system.

### **CITY OF CALEDONIA, MICHIGAN**

Project manager and design engineer for planning and design of wastewater system improvements to the existing SBR WWTP. Assisted in design validation, funding acquisition, and improvements design. Construction to begin in fall 2020.

### **CITY OF HILLSDALE, MICHIGAN**

Project engineer for design and construction of WWTP improvements including influent pumping, grit removal, primary clarification, primary sludge pumping, secondary clarification, RAS and WAS pumping, tertiary filtration, and anaerobic digester modifications.

### **CITY OF GRANDVILLE, MICHIGAN**

Design engineer for WWTP improvements including screening, grit removal, primary clarifiers, aeration basins, final clarifiers, UV system improvements, and anaerobic digestion with a cogeneration system to capture and beneficially reuse biogas.

### **CITY OF CHARLOTTE, MICHIGAN**

Design engineer for the implementation of a UV disinfection system at the WWTP, which replaced the existing chlorine disinfection system.

### **VILLAGE OF SARANAC, MICHIGAN**

Project engineer for replacement of the influent pumping system at the WWTP.

### **HOMESTEAD DAIRY, LLC | PLYMOUTH, INDIANA**

Design engineer for planning, design, and construction of an anaerobic digestion facility including co-digestion to increase biogas yield

### **MONTGOMERY COUNTY, INDIANA**

Design engineer for creation of a new collection system and SBR WWTP. The sanitary sewer system replaced failing onsite treatment systems and allowed continued economic growth in the area.

### **CITY OF ZEELAND, MICHIGAN**

- Assisted with construction engineering for WWTP improvements, including screening, grit removal, sludge storage, and a non-potable water system.
- Project engineer for design and construction of a high-pressure booster pump replacement project for the BPU

### **CITY OF GRAND RAPIDS, MICHIGAN**

Assisted with design and construction engineering for a sanitary lift station replacement project.



## LIZ MARSH, PE, CHMM

### SENIOR ENVIRONMENTAL ENGINEER

Liz specializes in auditing, regulatory compliance, due diligence, and emergency response activities with a focus on waste management - including Resource Conservation and Recovery Act (RCRA) and Toxic Substance Control Act (TSCA) waste. She specializes in regulatory compliance and due diligence for the automotive, food, consumer goods, utilities, rail, and oil and gas sectors. Liz's environmental compliance experience includes hands-on experience at two automotive manufacturing plants, managing the solid and hazardous waste in addition to the recycling. She is an experienced multimedia environmental compliance auditor, leading or participating in over 100 environmental compliance audits across the world. She has helped clients develop and maintain environmental compliance programs and management systems. Liz also has site investigation, remediation, plant decommissioning, closure, and demolition experience.

#### YEARS OF EXPERIENCE

3 years — Fishbeck  
25 years — total

#### EDUCATION

Graduate Certificate in  
Hazardous Waste Control, Wayne  
State University

BS in Civil/Environmental  
Engineering, University of  
Michigan

#### REGISTRATIONS/ CERTIFICATIONS

Professional Engineer - Michigan

Certified Hazardous Materials  
Manager

HAZWOPER Site Worker

MDEQ Stormwater Management  
Certification for Industrial Sites

#### TRAINING

USDOT Hazardous Materials  
Shipping

#### AFFILIATIONS

Alliance of Hazardous Materials  
Professionals

- Director, 2011-2014
- Secretary, 2015
- Awards Committee Member, 2016

## EXPERIENCE

### ENVIRONMENTAL PROGRAMS

#### CITY OF FLINT, MICHIGAN

##### RISK MANAGEMENT PLAN (RMP) AND PROCESS SAFETY MANAGEMENT (PSM)

Project engineer and lead auditor for RMP and PSM audits. Prepared RMP submittal and updated RMP and PSM documentation.

#### CITY OF KALAMAZOO, MICHIGAN

##### RISK MANAGEMENT PLAN

Project engineer and lead auditor for RMP audit. Prepared RMP submittal and updated RMP documentation.

#### ALLNEX | KALAMAZOO, MICHIGAN

##### RISK MANAGEMENT PLAN

Project engineer and lead auditor for RMP audit. Prepared RMP submittal.

### VARIOUS MANUFACTURING AND INDUSTRIAL PLANTS | THROUGHOUT UNITED STATES (28 STATES AND 1 TERRITORY)

#### ENVIRONMENTAL COMPLIANCE AUDITING AND SUPPORT

Project manager and lead auditor for multimedia environmental compliance audits addressing the following topics:

- Emergency Planning and Community Right-To-Know Act (EPCRA)
- Air emissions
- Hazardous and solid waste (RCRA)
- Stormwater discharge
- Hazardous materials transportation
- TSCA
- Industrial wastewater discharge
- Spill prevention, control, and countermeasures (SPCC)
- National Pollutant Discharge Elimination System (NPDES)
- Drinking water
- UST
- Federal Insecticide, Fungicide, and Rodenticide Act (FIFRA)
- Manufacturing plants include:
  - Boat manufacturing
  - Engine manufacturing
  - Glass manufacturing



## **LIZ MARSH, PE, CHMM**

### **SENIOR ENVIRONMENTAL ENGINEER**

#### **AFFILIATIONS, CONTINUED**

Certified Hazardous Materials  
Managers, Michigan Chapter

- President and Chairperson of Membership Committee, 2009
- Past President, 2010
- Director, 2011-2012, 2018-Present
- Chairperson of Education Committee, 2013

- Aerospace propulsion manufacturing
- Bowling products manufacturing
- Fitness equipment manufacturing
- Food manufacturing

Industrial facilities include:

- Treatment, storage, and disposal facilities (TSDFs)
- Light product terminals
- Asphalt terminals
- Salt storage terminals
- Coke batteries
- Oilseeds processing
- Railroad yards
- Marine distribution facilities

#### **VARIOUS ACTIVE MANUFACTURING AND INDUSTRIAL PLANTS | THROUGHOUT UNITED STATES (28 STATES AND 1 TERRITORY) REGULATORY COMPLIANCE ASSISTANCE**

Developed and implemented processes and procedures to maintain environmental compliance with permits. Prepared and submitted required reporting requirements associated with:

- Air emissions
- Hazardous and solid waste (RCRA)
- EPCRA
- Industrial wastewater discharge
- NPDES

#### **GENERAL MOTORS CORPORATION | MICHIGAN AND NEW YORK REGULATORY COMPLIANCE ASSISTANCE**

Member of decommissioning team tasked with identifying environmental liabilities prior to plant decommissioning and closure. Reviewed and cataloged historical environmental files for use after plant closure. Closed applicable environmental permits associated with manufacturing activities. Developed and implemented processes and procedures to maintain environmental compliance with permits remaining after plant closure. Prepared and submitted required reports associated with air emissions, hazardous waste, EPCRA, industrial wastewater discharge, and NPDES.

#### **FORD MOTOR COMPANY | MINNESOTA AND VIRGINIA REGULATORY COMPLIANCE ASSISTANCE**

Member of decommissioning team tasked with identifying environmental liabilities prior to plant decommissioning and closure. Reviewed and cataloged historical environmental files for use after plant closure.

#### **CSX TRANSPORTATION | KENTUCKY REGULATORY COMPLIANCE ASSISTANCE AT LARGE-SCALE DERAILMENT**

Member of onsite emergency response team. Tasked with characterization, profiling, and management of nonhazardous and hazardous waste generated during spill cleanup. Developed and implemented processes and procedures to track waste movement from derailment area into appropriate waste container at the waste storage area. Developed and implemented waste shipping processes and procedures. Obtained contained-in determination from state agency to minimize hazardous waste.

#### **GENERAL MOTORS CORPORATION | MULTIPLE SITES, MICHIGAN ISO 14001 IMPLEMENTATION**

Key member of cross-functional team that successfully implemented ISO 14001 and project manager/coordinator responsible for developing procedures for ISO 14001 implementation for various locations in Michigan.



### LIST OF REFERENCES: (3) SIMILAR SCOPE OF WORK FROM THE LAST 5 YEARS

Providing the following contact information enables the City of Flint to contact those accounts as references.

#### Reference #1:

Company/Municipality: Coldwater Board of Public Utilities | Coldwater, Michigan

Contact Person: Jon Foley Title: WWTP Superintendent

Address: 1 Grand Street

City: Coldwater State: Michigan Zip: 49036

Telephone: 517.279.9531 Fax: \_\_\_\_\_

Email: jfoley@coldwater.org

Type of Project: Technical and regulatory assistance: evaluation of local limits, SAL Program, Manual of Procedures, Enforcement Response Plan, Surcharge rate evaluation; industrial user permits development and reviews.

Project Timeline (Dates): 2017 - Present Budget: \$9,500 per fiscal year

#### Reference #2:

Company/Municipality: City of Ionia, Michigan

Contact Person: Chris Kenyon Title: Utilities Director

Address: 720 Wells Street

City: Ionia State: Michigan Zip: 48846

Telephone: 616.523.0165 Fax: \_\_\_\_\_

Email: CKenyon@ci.ionia.mi.us

Type of Project: Technical/regulatory assistance: NPDES permit compliance, reissuance, negotiations with EGLE; assistance with IPP and Mercury PMP; compliance with EGLE IPP PFAS Initiative, other WWTP-related regulatory issues as required.

Project Timeline (Dates): 2004 - Present Budget: \$60,000 annually

#### Reference #3:

Company/Municipality: City of Ann Arbor, Michigan

Contact Person: Keith Sanders Title: Wastewater Treatment Services Assistant Mgr.

Address: 49 South Dixboro Road

City: Ann Arbor State: Michigan Zip: 48105

Telephone: 734.794.6450 Fax: \_\_\_\_\_

Email: ksanders@a2gov.org

Type of Project: Technical and regulatory assistance: NPDES permit compliance and negotiations with EGLE, administration of IPP, assistance with Mercury PMP, other WWTP-related regulatory issues as they arise.

Project Timeline (Dates): 2005 - Present Budget: \$24,500 per fiscal year

**Certification Regarding  
Debarment, Suspension, and Other Responsibility Matters**

**BID#:** 21000533

The prospective participant certifies, to the best of its knowledge and belief, that it, its principals, and that of their subcontractor and/ or sub-subcontractors and their principals:

- 1) Are not presently or proposed to be debarred or suspended, declared ineligible, or voluntarily excluded from federal, state, or local (hereinafter "public") transactions;
- 2) Have not within a three-year period preceding this Agreement been convicted of or had a civil judgment rendered against them for
  - i. Fraud or commission of a criminal offence in connection with obtaining, attempting to obtain, or performing a public transaction or contract under a public transaction,
  - ii. Violation of federal or state antitrust laws, or
  - iii. Embezzlement, theft, forgery, bribery, falsification or destruction of records, making false statements or receiving stolen property;
- 3) Have not within the preceding three years had a public transaction terminated for cause or default; and
- 4) Are not presently indicted for or otherwise criminally or civilly charged by a public entity with commission of any of the offenses enumerated under the above.

I understand that a false statement on this certification may be grounds for the rejection of this proposal or the termination of the award.

Jeffrey J. Brown, PE | Principal, Senior Vice President

Name and Title of Authorized Representative

Fishbeck

Name of Participant Agency or Firm

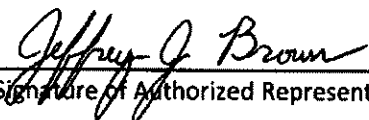
  
Signature of Authorized Representative

6/17/2020

Date

I am unable to certify to the above statement. Attached is my explanation.



**CITY OF FLINT, MICHIGAN AFFIDAVIT**

**AFFIDAVIT FOR INDIVIDUAL**

STATE OF \_\_\_\_\_

S.S.

COUNTY OF \_\_\_\_\_

\_\_\_\_\_ being duly sworn, deposes and says that they are the person making the above bid; and that said bid is genuine and not sham or collusive, and is not made in the interest of or on behalf of any person not therein named, and that they have not directly or indirectly induced or solicited any bidder to put in a sham bid; that they have not directly or indirectly induced or solicited any other person or corporation to refrain from bidding, and that they have not in any manner sought by collusion to secure themselves any advantage over other bidders.

Subscribed and sworn to before me at \_\_\_\_\_, in said County and State,

this \_\_\_\_\_ day of \_\_\_\_\_, A.D. 20 \_\_\_\_\_,

\_\_\_\_\_  
\*Notary Public, \_\_\_\_\_ County, \_\_\_\_\_

My Commission expires \_\_\_\_\_, 20 \_\_\_\_\_

**FOR CORPORATION**

STATE OF Michigan

S.S.

COUNTY OF Kent

Jeffrey J. Brown, PE being duly sworn, deposes and says that she/he/they is Principal/Sr. Vice President of Fishbeck

(Official Title)

(Name of Corporation)

a corporation duly organized and doing business under the laws of the State of Michigan the corporation making the within and foregoing bid; that they executed said bid in behalf of said corporation by authority of its Board of Directors; that said bid is genuine and not sham or collusive and is not made in the interests of or on behalf of any person not herein named, and that they have not and said bidder has not directly or indirectly induced or solicited any other person or corporation to refrain from bidding; that they have not and said bidder has not in any manner sought by collusion to secure to themselves or to said corporation an advantage over other bidders.

Subscribed and sworn to before me at Kent County, MI, in said County and State,

this 15th day of June, A.D. 20 20

Laura A. Carson  
NOTARY PUBLIC, STATE OF MI  
COUNTY OF KENT  
MY COMMISSION EXPIRES 11/17, 2025  
ACTING IN COUNTY OF KENT

\*Notary Public Laura A. Carson County, \_\_\_\_\_

My Commission expires March 27, 20 26

**FOR PARTNERSHIP**

STATE OF \_\_\_\_\_

S.S.

COUNTY OF \_\_\_\_\_

\_\_\_\_\_ being duly sworn, deposes and says that they are a member of the firm of \_\_\_\_\_, a co-partnership, making the above bid; that they are duly authorized to make said bid on behalf of said co-partnership; that said bid is genuine and not sham or collusive, and is not made in the interest of or on behalf of any person not therein named, and that they have and said bidder has not directly or indirectly induced or solicited any other person or corporation to refrain from bidding, and that they have not and said bidder has not in any manner sought by collusion to secure to themselves or to said bidder any advantage over other bidders.

Subscribed and sworn to before me at \_\_\_\_\_, in said County and State,

this \_\_\_\_\_ day of \_\_\_\_\_, A.D. 20\_\_\_\_\_

\_\_\_\_\_

\*Notary Public, \_\_\_\_\_ County, \_\_\_\_\_

My Commission expires \_\_\_\_\_, 20\_\_\_\_\_

**FOR AGENT**

STATE OF \_\_\_\_\_

S.S.

COUNTY OF \_\_\_\_\_

\_\_\_\_\_ being duly sworn, deposes and says that they executed the within and foregoing bid in behalf of \_\_\_\_\_, the bidder therein named, they having been theretofore lawfully authorized, as the agent of said bidder, so to do; that said bid is genuine and not sham or collusive and not made in the interests of or on behalf of any person not therein named, and that they have not and said bidder has not directly or indirectly induced or solicited any bidder to put in a sham bid; that they have not and said bidder has not directly or indirectly induced or solicited any other person or corporation to refrain from bidding, and that they have not and said bidder has not in any manner sought by collusion to secure to themselves or to said bidder any advantage over other bidders.

Subscribed and sworn to before me at \_\_\_\_\_, in said County and State,

this \_\_\_\_\_ day of \_\_\_\_\_, A.D. 20\_\_\_\_\_

\_\_\_\_\_

\*Notary Public, \_\_\_\_\_ County, \_\_\_\_\_

My Commission expires \_\_\_\_\_, 20\_\_\_\_\_

*NOTE: If executed outside of the State of Michigan, certificate by the Clerk of the Court of Record, authenticating the Notary's Signature and authority should be attached.*



RESOLUTION NO.: 210267

PRESENTED: JUN - 6 2021

ADOPTED: \_\_\_\_\_

(Proposal #20000558)

BY THE CITY ADMINISTRATOR:

**RESOLUTION TO SPALDING DEDECKER FOR PRELIMINARY ENGINEERING (PE) TO REHABILITATE MILLER RD. FROM HAMMERBERG TO BALLENGER HWY. CHANGE ORDER**

On May 26, 2020, the Proper City Officials were authorized to enter into a contract per resolution #210214 with Spalding DeDecker, 905 South Blvd. East, Rochester Hills, Michigan for Preliminary Engineering (PE) services to rehabilitate Miller Rd. from Hammerberg to Ballenger Hwy. in an amount not to exceed \$209,508.09, and

The original scope of work included a water main design for the entire length of the project. This was removed from the scope of work between the submittal of the preliminary plans and the final submittal package to MDOT. This caused substantial revisions to the design. The cost of removing the water main and making substantial changes to the design has resulting in additional fees in the amount of \$25,000.00. Funding for said services will come from the following account:

496-555.000-801.066 FEPA18WIIN-1	Water Capital Projects Grant Fund	\$25,000.00
-------------------------------------	-----------------------------------	-------------

**IT IS RESOLVED**, that the Proper City Officials, upon City Council's approval, are hereby authorized to enter into change order #1 to the contract with Spalding DeDecker to facilitate a design change during the Preliminary Engineering (PE) Services to rehabilitate Miller Rd., in an amount not to exceed \$25,000.00 and a revised aggregate amount of \$234,508.09. (Water Capital Projects Fund)

APPROVED PURCHASING DEPT:

Jennifer Ryan  
Jennifer Ryan (Jun 2, 2021 11:45 EDT)

Jennifer Ryan  
Deputy Finance Director

APPROVED AS TO FINANCE:

Shelbi Frayer  
Shelbi Frayer (Jun 2, 2021 11:54 EDT)

Shelbi Frayer  
Chief Finance Officer

APPROVED AS TO FORM:

Angela Wheeler  
Angela Wheeler, Chief Legal Officer

CLYDE D EDWARDS  
CLYDE D EDWARDS (Jun 2, 2021 12:37 EDT)

Clyde Edwards, City Administrator

CITY COUNCIL:

Kate Fields  
Kate Fields, Council President

**RESOLUTION STAFF REVIEW FORM**

**TODAY'S DATE:** May 21, 2021

**BID/PROPOSAL#** 20000558

**AGENDA ITEM TITLE:** Resolution for design changes to the Miller Rd. rehabilitation

**PREPARED BY** Kathryn Neumann for Michael Brown, Director of Public Works

**VENDOR NAME:** Spalding DeDecker

**BACKGROUND/SUMMARY OF PROPOSED ACTION:**

On May 26, 2020, the Proper City Officials authorized the issuance of a contract to Spalding DeDecker for the Miller Rd. rehabilitation from Hammerberg to Ballenger Hwy. The original scope of work included a water main design for the entire length of the project. This was removed from the scope of work between the submittal of the preliminary plans and the final submittal package to MDOT. This caused substantial revisions to the design. The cost of removing the water main and making substantial changes to the design has resulting in additional fees in the amount of \$25,000.00

**FINANCIAL IMPLICATIONS:** There is money in the account listed below.

**BUDGETED EXPENDITURE?** YES  NO  IF NO, PLEASE EXPLAIN:

Dept.	Name of Account	Account Number	Grant Code	Amount
496	Water Capital Projects Grant Fund	555.000-801.066	FEP18WIN-1	\$25,000.00

**PRE-ENCUMBERED?** YES  NO  REQUISITION NO: 21004565

**ACCOUNTING APPROVAL:** Kirstie Troup Date: 5/21/21

**WILL YOUR DEPARTMENT NEED A CONTRACT?** YES  NO   
(If yes, please indicate how many years for the contract) 1 YEAR

**OTHER IMPLICATIONS (i.e., collective bargaining):** None

**STAFF RECOMMENDATION: (PLEASE SELECT):**  APPROVED  NOT APPROVED

**DEPARTMENT HEAD SIGNATURE:**

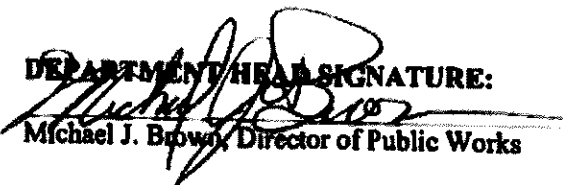
  
Michael J. Brown, Director of Public Works

# FACT SHEET: The Coronavirus State and Local Fiscal Recovery Funds Will Deliver \$350 Billion for State, Local, Territorial, and Tribal Governments to Respond to the COVID-19 Emergency and Bring Back Jobs

May 10, 2021

*Aid to state, local, territorial, and Tribal governments will help turn the tide on the pandemic, address its economic fallout, and lay the foundation for a strong and equitable recovery*

Today, the U.S. Department of the Treasury announced the launch of the Coronavirus State and Local Fiscal Recovery Funds, established by the American Rescue Plan Act of 2021, to provide \$350 billion in emergency funding for eligible state, local, territorial, and Tribal governments. Treasury also released details on how these funds can be used to respond to acute pandemic response needs, fill revenue shortfalls among these governments, and support the communities and populations hardest-hit by the COVID-19 crisis. With the launch of the Coronavirus State and Local Fiscal Recovery Funds, eligible jurisdictions will be able to access this funding in the coming days to address these needs.

State, local, territorial, and Tribal governments have been on the frontlines of responding to the immense public health and economic needs created by this crisis – from standing up vaccination sites to supporting small businesses – even as these governments confronted revenue shortfalls during the downturn. As a result, these governments have endured unprecedented strains, forcing many to make untenable choices between laying off educators, firefighters, and other frontline workers or failing to provide other services that communities rely on. Faced with these challenges, state and local governments have cut over 1 million jobs since the beginning of the crisis. The experience of prior economic downturns has shown that budget pressures like these often result in prolonged fiscal austerity that can slow an economic recovery.

To support the immediate pandemic response, bring back jobs, and lay the groundwork for a strong and equitable recovery, the American Rescue Plan Act of 2021 established the Coronavirus State and Local Fiscal Recovery Funds, designed to deliver \$350 billion to state, local, territorial, and Tribal governments to bolster their response to the COVID-19 emergency and its economic impacts. Today, Treasury is launching this much-needed relief to:

- Support urgent COVID-19 response efforts to continue to decrease spread of the virus and bring the pandemic under control;
- Replace lost public sector revenue to strengthen support for vital public services and help retain jobs;
- Support immediate economic stabilization for households and businesses; and,
- Address systemic public health and economic challenges that have contributed to the unequal impact of the pandemic on certain populations.

The Coronavirus State and Local Fiscal Recovery Funds provide substantial flexibility for each jurisdiction to meet local needs—including support for households, small businesses, impacted industries, essential workers, and the communities hardest-hit by the crisis. These funds also deliver resources that recipients can invest in building, maintaining, or upgrading their water, sewer, and broadband infrastructure.



Starting today, eligible state, territorial, metropolitan city, county, and Tribal governments may request Coronavirus State and Local Fiscal Recovery Funds through the Treasury Submission Portal. Concurrent with this program launch, Treasury has published an Interim Final Rule that implements the provisions of this program.

## **FUNDING AMOUNTS**

The American Rescue Plan provides a total of \$350 billion in Coronavirus State and Local Fiscal Recovery Funds to help eligible state, local, territorial, and Tribal governments meet their present needs and build the foundation for a strong recovery. Congress has allocated this funding to tens of thousands of jurisdictions. These allocations include:

<b>Type</b>	<b>Amount (\$ billions)</b>
States & District of Columbia	\$195.3
Counties	\$65.1
Metropolitan Cities	\$45.6
Tribal Governments	\$20.0
Territories	\$4.5
Non-Entitlement Units of Local Government	\$19.5

Treasury expects to distribute these funds directly to each state, territorial, metropolitan city, county, and Tribal government. Local governments that are classified as non-entitlement units will receive this funding through their applicable state government. Treasury expects to provide further guidance on distributions to non-entitlement units next week.

Local governments should expect to receive funds in two tranches, with 50% provided beginning in May 2021 and the balance delivered 12 months later. States that have experienced a net increase in the unemployment rate of more than 2 percentage points from February 2020 to the latest available data as of the date of certification will receive their full allocation of funds in a single payment; other states will receive funds in two equal tranches. Governments of U.S. territories will receive a single payment. Tribal governments will receive two payments, with the first payment available in May and the second payment, based on employment data, to be delivered in June 2021.

## **USES OF FUNDING**

Coronavirus State and Local Fiscal Recovery Funds provide eligible state, local, territorial, and Tribal governments with a substantial infusion of resources to meet pandemic response needs and rebuild a stronger, more equitable economy as the country recovers. Within the categories of eligible uses, recipients have broad flexibility to decide how best to use this funding to meet the needs of their communities. Recipients may use Coronavirus State and Local Fiscal Recovery Funds to:

- **Support public health expenditures**, by funding COVID-19 mitigation efforts, medical expenses, behavioral healthcare, and certain public health and safety staff;
- **Address negative economic impacts caused by the public health emergency**, including economic harms to workers, households, small businesses, impacted industries, and the public sector;
- **Replace lost public sector revenue**, using this funding to provide government services to the extent of the reduction in revenue experienced due to the pandemic;
- **Provide premium pay for essential workers**, offering additional support to those who have borne and will bear the greatest health risks because of their service in critical infrastructure sectors; and,
- **Invest in water, sewer, and broadband infrastructure**, making necessary investments to improve access to clean drinking water, support vital wastewater and stormwater infrastructure, and to expand access to broadband internet.

Within these overall categories, Treasury’s Interim Final Rule provides guidelines and principles for determining the types of programs and services that this funding can support, together with examples of allowable uses that recipients may consider. As described below, Treasury has also designed these provisions to take into consideration the disproportionate impacts of the COVID-19 public health emergency on those hardest-hit by the pandemic.

### 1. Supporting the public health response

Mitigating the impact of COVID-19 continues to require an unprecedented public health response from state, local, territorial, and Tribal governments. Coronavirus State and Local Fiscal Recovery Funds provide resources to meet these needs through the provision of care for those impacted by the virus and through services that address disparities in public health that have been exacerbated by the pandemic. Recipients may use this funding to address a broad range of public health needs across COVID-19 mitigation, medical expenses, behavioral healthcare, and public health resources. Among other services, these funds can help support:

- **Services and programs to contain and mitigate the spread of COVID-19, including:**
  - ✓ Vaccination programs
  - ✓ Medical expenses
  - ✓ Testing
  - ✓ Contact tracing
  - ✓ Isolation or quarantine
  - ✓ PPE purchases
  - ✓ Support for vulnerable populations to access medical or public health services
  - ✓ Public health surveillance (e.g., monitoring for variants)
  - ✓ Enforcement of public health orders
  - ✓ Public communication efforts
  - ✓ Enhancement of healthcare capacity, including alternative care facilities
  - ✓ Support for prevention, mitigation, or other services in congregate living facilities and schools
  - ✓ Enhancement of public health data systems
  - ✓ Capital investments in public facilities to meet pandemic operational needs
  - ✓ Ventilation improvements in key settings like healthcare facilities

- **Services to address behavioral healthcare needs exacerbated by the pandemic, including:**
  - ✓ Mental health treatment
  - ✓ Substance misuse treatment
  - ✓ Other behavioral health services
  - ✓ Hotlines or warmlines
  - ✓ Crisis intervention
  - ✓ Services or outreach to promote access to health and social services
- **Payroll and covered benefits expenses** for public health, healthcare, human services, public safety and similar employees, to the extent that they work on the COVID-19 response. For public health and safety workers, recipients can use these funds to cover the full payroll and covered benefits costs for employees or operating units or divisions primarily dedicated to the COVID-19 response.

## 2. Addressing the negative economic impacts caused by the public health emergency

The COVID-19 public health emergency resulted in significant economic hardship for many Americans. As businesses closed, consumers stayed home, schools shifted to remote education, and travel declined precipitously, over 20 million jobs were lost between February and April 2020. Although many have since returned to work, as of April 2021, the economy remains more than 8 million jobs below its pre-pandemic peak, and more than 3 million workers have dropped out of the labor market altogether since February 2020.

To help alleviate the economic hardships caused by the pandemic, Coronavirus State and Local Fiscal Recovery Funds enable eligible state, local, territorial, and Tribal governments to provide a wide range of assistance to individuals and households, small businesses, and impacted industries, in addition to enabling governments to rehire public sector staff and rebuild capacity. Among these uses include:

- **Delivering assistance to workers and families**, including aid to unemployed workers and job training, as well as aid to households facing food, housing, or other financial insecurity. In addition, these funds can support survivor's benefits for family members of COVID-19 victims.
- **Supporting small businesses**, helping them to address financial challenges caused by the pandemic and to make investments in COVID-19 prevention and mitigation tactics, as well as to provide technical assistance. To achieve these goals, recipients may employ this funding to execute a broad array of loan, grant, in-kind assistance, and counseling programs to enable small businesses to rebound from the downturn.
- **Speeding the recovery of the tourism, travel, and hospitality sectors**, supporting industries that were particularly hard-hit by the COVID-19 emergency and are just now beginning to mend. Similarly impacted sectors within a local area are also eligible for support.
- **Rebuilding public sector capacity**, by rehiring public sector staff and replenishing unemployment insurance (UI) trust funds, in each case up to pre-pandemic levels. Recipients may also use this funding to build their internal capacity to successfully implement economic relief programs, with investments in data analysis, targeted outreach, technology infrastructure, and impact evaluations.

### 3. **Serving the hardest-hit communities and families**

While the pandemic has affected communities across the country, it has disproportionately impacted low-income families and communities of color and has exacerbated systemic health and economic inequities. Low-income and socially vulnerable communities have experienced the most severe health impacts. For example, counties with high poverty rates also have the highest rates of infections and deaths, with 223 deaths per 100,000 compared to the U.S. average of 175 deaths per 100,000.

Coronavirus State and Local Fiscal Recovery Funds allow for a broad range of uses to address the disproportionate public health and economic impacts of the crisis on the hardest-hit communities, populations, and households. Eligible services include:

- **Addressing health disparities and the social determinants of health**, through funding for community health workers, public benefits navigators, remediation of lead hazards, and community violence intervention programs;
- **Investments in housing and neighborhoods**, such as services to address individuals experiencing homelessness, affordable housing development, housing vouchers, and residential counseling and housing navigation assistance to facilitate moves to neighborhoods with high economic opportunity;
- **Addressing educational disparities** through new or expanded early learning services, providing additional resources to high-poverty school districts, and offering educational services like tutoring or afterschool programs as well as services to address social, emotional, and mental health needs; and,
- **Promoting healthy childhood environments**, including new or expanded high quality childcare, home visiting programs for families with young children, and enhanced services for child welfare-involved families and foster youth.

Governments may use Coronavirus State and Local Fiscal Recovery Funds to support these additional services if they are provided:

- within a Qualified Census Tract (a low-income area as designated by the Department of Housing and Urban Development);
- to families living in Qualified Census Tracts;
- by a Tribal government; or,
- to other populations, households, or geographic areas disproportionately impacted by the pandemic.

### 4. **Replacing lost public sector revenue**

State, local, territorial, and Tribal governments that are facing budget shortfalls may use Coronavirus State and Local Fiscal Recovery Funds to avoid cuts to government services. With these additional resources, recipients can continue to provide valuable public services and ensure that fiscal austerity measures do not hamper the broader economic recovery.

Many state, local, territorial, and Tribal governments have experienced significant budget shortfalls, which can yield a devastating impact on their respective communities. Faced with budget shortfalls and pandemic-related uncertainty, state and local governments cut staff in all 50 states. These budget shortfalls and staff cuts are particularly problematic at present, as these entities are on the front lines of battling the COVID-19 pandemic and helping citizens weather the economic downturn.

Recipients may use these funds to replace lost revenue. Treasury's Interim Final Rule establishes a methodology that each recipient can use to calculate its reduction in revenue. Specifically, recipients will compute the extent of their reduction in revenue by comparing their actual revenue to an alternative representing what could have been expected to occur in the absence of the pandemic. Analysis of this expected trend begins with the last full fiscal year prior to the public health emergency and projects forward at either (a) the recipient's average annual revenue growth over the three full fiscal years prior to the public health emergency or (b) 4.1%, the national average state and local revenue growth rate from 2015-18 (the latest available data).

For administrative convenience, Treasury's Interim Final Rule allows recipients to presume that any diminution in actual revenue relative to the expected trend is due to the COVID-19 public health emergency. Upon receiving Coronavirus State and Local Fiscal Recovery Funds, recipients may immediately calculate the reduction in revenue that occurred in 2020 and deploy funds to address any shortfall. Recipients will have the opportunity to re-calculate revenue loss at several points through the program, supporting those entities that experience a lagged impact of the crisis on revenues.

Importantly, once a shortfall in revenue is identified, recipients will have broad latitude to use this funding to support government services, up to this amount of lost revenue.

#### **5. Providing premium pay for essential workers**

Coronavirus State and Local Fiscal Recovery Funds provide resources for eligible state, local, territorial, and Tribal governments to recognize the heroic contributions of essential workers. Since the start of the public health emergency, essential workers have put their physical well-being at risk to meet the daily needs of their communities and to provide care for others.

Many of these essential workers have not received compensation for the heightened risks they have faced and continue to face. Recipients may use this funding to provide premium pay directly, or through grants to private employers, to a broad range of essential workers who must be physically present at their jobs including, among others:

- ✓ Staff at nursing homes, hospitals, and home-care settings
- ✓ Workers at farms, food production facilities, grocery stores, and restaurants
- ✓ Janitors and sanitation workers
- ✓ Public health and safety staff
- ✓ Truck drivers, transit staff, and warehouse workers
- ✓ Childcare workers, educators, and school staff
- ✓ Social service and human services staff

Treasury's Interim Final Rule emphasizes the need for recipients to prioritize premium pay for lower income workers. Premium pay that would increase a worker's total pay above 150% of the greater of the state or county average annual wage requires specific justification for how it responds to the needs of these workers.

In addition, employers are both permitted and encouraged to use Coronavirus State and Local Fiscal Recovery Funds to offer retrospective premium pay, recognizing that many essential workers have not yet received additional compensation for work performed. Staff working for third-party contractors in eligible sectors are also eligible for premium pay.

#### **6. Investing in water and sewer infrastructure**

Recipients may use Coronavirus State and Local Fiscal Recovery Funds to invest in necessary improvements to their water and sewer infrastructures, including projects that address the impacts of climate change.

Recipients may use this funding to invest in an array of drinking water infrastructure projects, such as building or upgrading facilities and transmission, distribution, and storage systems, including the replacement of lead service lines.

Recipients may also use this funding to invest in wastewater infrastructure projects, including constructing publicly-owned treatment infrastructure, managing and treating stormwater or subsurface drainage water, facilitating water reuse, and securing publicly-owned treatment works.

To help jurisdictions expedite their execution of these essential investments, Treasury's Interim Final Rule aligns types of eligible projects with the wide range of projects that can be supported by the Environmental Protection Agency's Clean Water State Revolving Fund and Drinking Water State Revolving Fund. Recipients retain substantial flexibility to identify those water and sewer infrastructure investments that are of the highest priority for their own communities.

Treasury's Interim Final Rule also encourages recipients to ensure that water, sewer, and broadband projects use strong labor standards, including project labor agreements and community benefits agreements that offer wages at or above the prevailing rate and include local hire provisions.

#### **7. Investing in broadband infrastructure**

The pandemic has underscored the importance of access to universal, high-speed, reliable, and affordable broadband coverage. Over the past year, millions of Americans relied on the internet to participate in remote school, healthcare, and work.

Yet, by at least one measure, 30 million Americans live in areas where there is no broadband service or where existing services do not deliver minimally acceptable speeds. For millions of other Americans, the high cost of broadband access may place it out of reach. The American Rescue Plan aims to help remedy these shortfalls, providing recipients with flexibility to use Coronavirus State and Local Fiscal Recovery Funds to invest in broadband infrastructure.

Recognizing the acute need in certain communities, Treasury's Interim Final Rule provides that investments in broadband be made in areas that are currently unserved or underserved—in other words, lacking a wireline connection that reliably delivers minimum speeds of 25 Mbps download and 3 Mbps upload. Recipients are also encouraged to prioritize projects that achieve last-mile connections to households and businesses.

Using these funds, recipients generally should build broadband infrastructure with modern technologies in mind, specifically those projects that deliver services offering reliable 100 Mbps download and 100

Mbps upload speeds, unless impracticable due to topography, geography, or financial cost. In addition, recipients are encouraged to pursue fiber optic investments.

In view of the wide disparities in broadband access, assistance to households to support internet access or digital literacy is an eligible use to respond to the public health and negative economic impacts of the pandemic, as detailed above.

#### 8. Ineligible Uses

Coronavirus State and Local Fiscal Recovery Funds provide substantial resources to help eligible state, local, territorial, and Tribal governments manage the public health and economic consequences of COVID-19. Recipients have considerable flexibility to use these funds to address the diverse needs of their communities.

To ensure that these funds are used for their intended purposes, the American Rescue Plan Act also specifies two ineligible uses of funds:

- **States and territories may not use this funding to directly or indirectly offset a reduction in net tax revenue due to a change in law from March 3, 2021 through the last day of the fiscal year in which the funds provided have been spent.** The American Rescue Plan ensures that funds needed to provide vital services and support public employees, small businesses, and families struggling to make it through the pandemic are not used to fund reductions in net tax revenue. Treasury's Interim Final Rule implements this requirement. If a state or territory cuts taxes, they must demonstrate how they paid for the tax cuts from sources other than Coronavirus State Fiscal Recovery Funds—by enacting policies to raise other sources of revenue, by cutting spending, or through higher revenue due to economic growth. If the funds provided have been used to offset tax cuts, the amount used for this purpose must be paid back to the Treasury.
- **No recipient may use this funding to make a deposit to a pension fund.** Treasury's Interim Final Rule defines a "deposit" as an extraordinary contribution to a pension fund for the purpose of reducing an accrued, unfunded liability. While pension deposits are prohibited, recipients may use funds for routine payroll contributions for employees whose wages and salaries are an eligible use of funds.

Treasury's Interim Final Rule identifies several other ineligible uses, including funding debt service, legal settlements or judgments, and deposits to rainy day funds or financial reserves. Further, general infrastructure spending is not covered as an eligible use outside of water, sewer, and broadband investments or above the amount allocated under the revenue loss provision. While the program offers broad flexibility to recipients to address local conditions, these restrictions will help ensure that funds are used to augment existing activities and address pressing needs.



RESOLUTION NO.: 210268  
PRESENTED: JUN - 6 2021  
ADOPTED: \_\_\_\_\_

**Resolution to Set a Public Hearing to consider a rezoning request for 448 S Saginaw St.  
(PID 41-18-107-019) from D-4 Metropolitan Business District to  
D-5 Metropolitan Commercial Services District.**

**BY THE CITY ADMINISTRATOR:**

The applicant, Shaltz Acquisitions LLC, requests a rezoning from D-4 to D-5 at 448 S. Saginaw Street. The applicant intends to use the property for a Provisioning Center. Provisioning Centers, a Group E Special Regulated use, require properties to be located in D-5, D-6, E, F, or G, zoning districts. This requires a public hearing.

A public hearing will be held on \_\_\_\_\_ at 5:30 pm p.m at the scheduled City Council Meeting. Pursuant to the amended Michigan Open Meetings Act and COVID 19 related Executive Orders, all City Council meetings are currently scheduled to be conducted electronically through StartMeeting by dialing (617)944-8177. This hearing is being held to provide for the opportunity for public comment on the rezoning request.

IT IS RESOLVED, that authorized officials will do all things necessary to schedule and hold a Public Hearing on \_\_\_\_\_ for the purposes of allowing for public comment on the rezoning request for 448 S. Saginaw St.

**APPROVED AS TO FORM:**

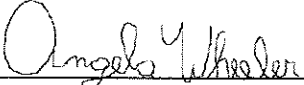
  
\_\_\_\_\_  
Angela Wheeler, Chief Legal Officer

**FOR THE CITY OF FLINT:**

  
\_\_\_\_\_  
Clyde Edwards, City Administrator

**APPROVED BY CITY COUNCIL:**

\_\_\_\_\_  
Kate Fields, City Council President



**RESOLUTION STAFF REVIEW FORM**

**TODAY'S DATE:** 02/08/2021

**BID/PROPOSAL#:** N/A

**AGENDA ITEM TITLE:** Resolution to Set a Public Hearing on xxx at 5:30 pm at the City of Flint Council Meeting to consider a rezoning request for 448 S Saginaw St. (PID 41-18-107-019) from D-4 Metropolitan Business District to D-5 Metropolitan Commercial Services District.

**PREPARED BY:** Planning and Zoning Staff  
*(Please type name and Department)*

**VENDOR NAME:** N/A

**BACKGROUND/SUMMARY OF PROPOSED ACTION:**

The applicant, Shaltz Acquisitions LLC, requests a rezoning from D-4 to D-5 at 448 S. Saginaw Street. The applicant intends to use the property for a Provisioning Center. Provisioning Centers, a Group E Special Regulated use, require properties to be located in D-5, D-6, E, F, or G, zoning districts. This requires a public hearing.

**FINANCIAL IMPLICATIONS:** N/A

**BUDGETED EXPENDITURE?** YES  NO  **IF NO, PLEASE EXPLAIN:** Public Hearing Only

Dept.	Name of Account	Account Number	Grant Code	Amount
<b>FY20/21 GRAND TOTAL</b>				

**PRE-ENCUMBERED?** YES  NO  **REQUISITION NO:** N/A

**ACCOUNTING APPROVAL:** N/A **Date:** \_\_\_\_\_

**WILL YOUR DEPARTMENT NEED A CONTRACT?** YES  NO   
*(If yes, please indicate how many years for the contract)* N/A YEARS

**OTHER IMPLICATIONS (i.e., collective bargaining):** Public Hearing to meet the requirements set forth as an ordinance requirement for rezoning requests.

**STAFF RECOMMENDATION: (PLEASE SELECT):**  **APPROVED**  **NOT APPROVE**

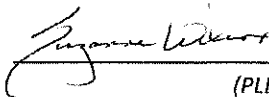
**DEPARTMENT HEAD SIGNATURE:**  Director, DPD  
*(PLEASE TYPE NAME, TITLE)*

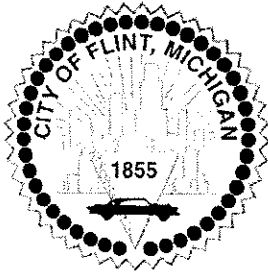

RESOLUTION NO.:

210270

JUN - 6 2021

PRESENTED:

ADOPTED:

**RESOLUTION RECOGNIZING BACK TO THE BRICKS INC., AS A NONPROFIT ORGANIZATION OPERATING IN THE CITY OF FLINT FOR THE PURPOSE OF OBTAINING A CHARITABLE GAMING LICENSE, ISSUED BY THE MICHIGAN LOTTERY CHARITABLE GAMING ORGANIZATION.**

**BY THE MAYOR:**

Back to the Bricks Inc., a non-profit organization, produces family focused events that educate the public about Flint, Michigan's automobile heritage and its impact upon the global automobile industry.

The City of Flint, being the local governing body with authority to grant local charitable gaming licenses that also conform to requirements set forth by the State of Michigan, and Back to the Bricks Inc., a non-profit organization, having made proper application for a Charitable Gaming License to conduct a 50/50 raffle on August 17, 2021 through August 2, 2021, in downtown Flint and the US -23 Drive in. Ticket prices are \$1.00 for 1 ticket and \$5.00 for 6 tickets. This resolution is submitted in accordance with the qualification process pursuant to the State of Michigan, Bureau of State Lottery, as allowed by Act 382 of the Public Act of 1972, as amended.

**NOW THEREFORE BE IT RESOLVED**, that Back to the Bricks Inc., is recognized as a non-profit organization operating in the City of Flint for the purpose of obtaining a charitable gaming license, issued by the State of Michigan Lottery Charitable Gaming Division, relative to conducting charity and fundraising events, as allowed by Act 382 of the Public Act of 1972, as amended.

**APPROVED AS TO FORM:**

**FOR THE CITY OF FLINT:**

  
Angela Wheeler, City Attorney

  
Sheldon A. Neeley, Mayor

**APPROVED BY CITY COUNCIL:**

\_\_\_\_\_  
Kate Fields, City Council President

**Documentation Needed for Preparation of Charitable Gaming License Resolution**

Full name of organization requesting Charitable Gaming Resolution

Mission Statement

Date(s) of event and type of event

Location of event: Name of event center with the complete address

Tax Exemption Letter

Price of Raffle Tickets and how many raffles will be taking place and what is the prize

Return all to Victoria Cooper, Litigation Assistant/Paralegal  
City Attorney's Office  
Telephone: 766-7146

S:\Bag\Charitable Gaming Licenses\Documents needed for processing reso.doc

April 29, 2021

City of Flint Attorney's Office  
1101 S. Saginaw Street  
Flint, MI 48501

Attention: Victoria Cooper

Dear Ms. Cooper,

Please be advised that I represent the Back to the Bricks, Inc. Enclosed please find the following documents which are being submitted pursuant to my client's request for a charitable gaming license which will allow it to conduct 50/50 raffles during certain events:

1. The full name of the organization is, "Back to the Bricks, Inc., a Michigan non-profit corporation".
2. Mission Statement: "To produce family-focused events that educate the public about Flint, Michigan's automobile heritage and its impact upon the global automobile industry."
3. Dates and types of events:
  - a. "Dust'em Off Car Show"  
May 23 2021  
Dort Event Center
  - b. Back to the Bricks annual car show  
August 17 - 21, 2021  
Downtown Flint and U.S. 23 Drive-in
4. IRS Tax Exemption letter: see included document.
5. Raffles will be the "50/50" type. Ticket cost: \$1 for 1 ticket and \$5 for 6 tickets.

**GEORGE KILLEEN**

*Attorney at Law, 218 Alhambra Beach, Bay City, MI, 48706, Telephone (810) 240-4600*

Thank you for your anticipated cooperation. If you have any additional questions or need any further documentation, please advise me at your earliest opportunity.

Sincerely,



George Killeen

Attorney for Back to the Bricks

INTERNAL REVENUE SERVICE  
P. O. BOX 2508  
CINCINNATI, OH 45201

DEPARTMENT OF THE TREASURY

Date:

MAR 07 2019

BACK TO THE BRICKS AUTOMOTIVE  
HERITAGE FUND  
4178 CALKINS RD  
FLINT, MI 48532-0000

Employer Identification Number:  
83-3244716  
DLN:  
26053437005809  
Contact Person:  
CUSTOMER SERVICE ID# 31954  
Contact Telephone Number:  
(877) 829-5500  
Accounting Period Ending:  
December 31  
Public Charity Status:  
509(a)(2)  
Form 990/990-EZ/990-N Required:  
Yes  
Effective Date of Exemption:  
September 28, 2018  
Contribution Deductibility:  
Yes  
Addendum Applies:  
No

Dear Applicant:

We're pleased to tell you we determined you're exempt from federal income tax under Internal Revenue Code (IRC) Section 501(c)(3). Donors can deduct contributions they make to you under IRC Section 170. You're also qualified to receive tax deductible bequests, devises, transfers or gifts under Section 2055, 2106, or 2522. This letter could help resolve questions on your exempt status. Please keep it for your records.

Organizations exempt under IRC Section 501(c)(3) are further classified as either public charities or private foundations. We determined you're a public charity under the IRC Section listed at the top of this letter.

If we indicated at the top of this letter that you're required to file Form 990/990-EZ/990-N, our records show you're required to file an annual information return (Form 990 or Form 990-EZ) or electronic notice (Form 990-N, the e-Postcard). If you don't file a required return or notice for three consecutive years, your exempt status will be automatically revoked.

If we indicated at the top of this letter that an addendum applies, the enclosed addendum is an integral part of this letter.

For important information about your responsibilities as a tax-exempt organization, go to [www.irs.gov/charities](http://www.irs.gov/charities). Enter "4221-PC" in the search bar to view Publication 4221-PC, Compliance Guide for 501(c)(3) Public Charities, which describes your recordkeeping, reporting, and disclosure requirements.

Letter 947

BACK TO THE BRICKS AUTOMOTIVE

Sincerely,

*Stephen A. Martin*

Director, Exempt Organizations  
Rulings and Agreements

For Internal Use Only

## QUALIFICATION INFORMATION

Complete this form and submit with the required qualification documents listed on the attached Qualification Requirements sheet. A Bingo, Raffle, or Charity Game Ticket license application and fee may also be submitted with this information. See box #5 below for mailing instructions.

### 1. ORGANIZATION INFORMATION

Organization Name Back to the Bricks, Inc.			
Organization Physical Street Address 4400 S. Saginaw St.			
City Flint	State Mi.	Zip Code 48507	County Genesee
Organization Mailing Address P.O. Box 500,			<input type="checkbox"/> Same as Physical Address
City Flint	State Mi	Zip Code 48501	County Genesee
Organization Telephone Number 810-877-8383			

### 2. ORGANIZATION PURPOSE

Briefly describe the purpose of your organization.

The purpose is to educate the public about the history of the automotive industry and evolution in Genesee County and to in furtherance to erect statutes and other lasting memorabilia of the original founders and inventors; to conduct automobile shows and events for the education and entertainment of the public so as to inspire the next generations of automotive leaders.

### 3. LICENSE APPLICATION

Enclosed is a completed application and fee for a  Bingo  Raffle  Charity Game Ticket license  
 Make checks payable to STATE OF MICHIGAN.

### 4. AUTHORIZED CONTACT PERSON

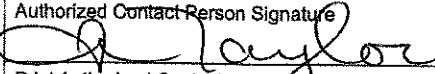
First Name Amber		Last Name Taylor		Position/Role with Organization Executive Director	
Mailing Address P.O. Box 500				City Flint	
State Mi.	Zip Code 48501	Telephone Number (Day) 810-877-8383	Telephone Number (Evening) same		
By signing below, I hereby certify that the representations, information, and data presented are true, accurate, and complete to the best of my knowledge. I understand that failure to answer truthfully, completely, and accurately could preclude the organization from receiving an approval to obtain a gaming license.					
Authorized Contact Person Signature 				Date 3/9/2021	
Print Authorized Contact Name and Title Amber Taylor, Executive Director					

### 5. MAILING INSTRUCTIONS

Mail this completed Qualification Information form, the required qualification documentation listed on the Qualification Requirements sheet, and the completed license application and fee (if also applying for a gaming license) to Charitable Gaming Division, PO Box 30023, Lansing, MI 48909. If submitting by overnight carrier (FedEx, UPS, etc.), send to Charitable Gaming Division, 101 East Hillsdale, Lansing, MI 48933.







RESOLUTION NO.: 210269  
 PRESENTED: JUN - 6 2021  
 ADOPTED: \_\_\_\_\_

BY THE CITY ADMINISTRATOR:

**RESOLUTION OF SUPPORT TO MOVE THE RESURFACING OF SAGINAW ST. FROM  
 ATHERTON RD. TO OAKLEY ST. FROM FY23 TO FY22**

On February 20, 2019, City Council authorized a resolution of support (resolution 190052) for FY2020-2023 Transportation Improvement Program (TIP) Projects to secure funding for improvements to Federal Aid Eligible Roads within the City of Flint’s jurisdiction. The following four projects were approved; the resurfacing of Miller Rd. from Ballenger Hwy. to Hammerberg Rd.; the resurfacing of Robert T. Longway Blvd. from Chavez Dr. to E. Boulevard Dr.; resurfacing of Saginaw St. from Atherton Rd. to Oakley St., and the resurfacing of Twelfth St. from Fenton Rd. to Grand Traverse St. for a total cost of \$4,780,196.00.

At the April 21, 2021 meeting, the Genesee County Metropolitan Alliance approved the following project for the City of Flint to move up a year, from FY2023 to FY2022: resurfacing of Saginaw St. from Atherton Rd. to Oakley St. This project has been programmed with the new Highway Infrastructure Program/COVID Relief funding. By using this money, the City will only pay a 13% local match, instead of a 20% match. The new local match will be \$61,882.00.

**IT IS RESOLVED**, That this resolution is adopted to attest the City’s support for moving the year for resurfacing of Saginaw St. from Atherton Rd. to Oakley St. from FY2023 to FY2022. The City of Flint’s local match is in the amount of \$61,882.00

**IT IS FURTHER RESOLVED**, That this resolution attests the City’s commitment to providing local funding for its share of the resurfacing of Saginaw St. from Atherton Rd. to Oakley St. in FY2022 that was previously selected for inclusion in the FY2020-2023 Transportation Improvement Program.

APPROVED AS TO FINANCE:

shelbi frayer  
shelbi frayer (May 26, 2021 12:26 EDT)  
 Shelbi Frayer, Chief Finance Officer

APPROVED AS TO FORM:

Angela Wheeler  
 Angela Wheeler, Chief Legal Officer

Clyde D Edwards  
Clyde D Edwards (May 26, 2021 14:24 EDT)  
 Clyde Edwards, City Administrator

CITY COUNCIL:

\_\_\_\_\_  
 Kate Fields, Council President

# Resolution Routing

**TO:** Resolution Signatories  
**FROM:** Dept. of Public Works  
**SUBJECT:** RESOLUTION FOR APPROVAL

This RESOLUTION has been forwarded to you for your respective review and approval.

**Date recorded:** May 21, 2021 **No.** 21-1225

**\*\* All documents should be reviewed within three (3) working days after receipt by your office.**

**Contractor:**

**Resolution of support**

**Resolution Content:**

**Resolution of support to move the resurfacing of Saginaw St.  
 from Atherton Rd. to Oakley from FY23 to FY22**

**\$0.00**

The attached resolution is submitted to the Legal Dept. for approval as to form only:

The **Legal Department** reviewed this **RESOLUTION**, as to form and by signing this form approves as to **FORM ONLY**.

Review and Approval:	<u>IN</u>	<u>OUT</u>	<u>APPROVAL</u>
1. City Attorney (Form Only):	<u>5/21</u>	<u>5-21</u>	<u></u>
2. Finance/Budget	<u>          </u>	<u>05/28/2021</u>	<u>Jennifer Ryan</u> <small>Jennifer Ryan May 28, 2021 09:14 EDT</small>
Mayor's Office	<u>          </u>	<u>          </u>	<u>          </u>

**\* Please call KATHRYN, ext. 2625, Thank You. \***

**RESOLUTION STAFF REVIEW FORM**

**TODAY'S DATE:** May 21, 2021

**BID/PROPOSAL#**

**AGENDA ITEM TITLE:** Resolution to move up by one year the resurfacing of Saginaw St. from Atherton Rd. to Oakley St.

**PREPARED BY** Kathryn Neumann for Michael Brown, Director of Public Works

**VENDOR NAME:**

**BACKGROUND/SUMMARY OF PROPOSED ACTION:**

On February 20, 2019, City Council authorized a resolution of support (resolution 190052) for the resurfacing of Saginaw St. from Atherton Rd. to Oakley St., for the fiscal year 2023. Since this project has been reprogrammed with the new Highway Infrastructure Program/COVID Relief funding, the project has been proposed to move up one year early, to fiscal year 2022. By using this money, the City will only pay a 13% local match, instead of a 20% match. The new local match will be \$61,882.00

**FINANCIAL IMPLICATIONS:** There will be TIP money available to pay the local match in FY2022

**BUDGETED EXPENDITURE?** YES  NO  IF NO, PLEASE EXPLAIN:

**PRE-ENCUMBERED?** YES  NO  **REQUISITION NO:**

**ACCOUNTING APPROVAL:** Kirstie Troup **Date:** 5/21/21

**WILL YOUR DEPARTMENT NEED A CONTRACT?** YES  NO   
(If yes, please indicate how many years for the contract) 1 YEAR

**OTHER IMPLICATIONS (i.e., collective bargaining):** None

**STAFF RECOMMENDATION: (PLEASE SELECT):**  **APPROVED**  **NOT APPROVED**

**DEPARTMENT HEAD SIGNATURE:**  
  
Michael J. Brown, Director of Public Works

210158

ORDINANCE NO. \_\_\_\_\_

An ordinance to amend the Code of the City of Flint by amending Chapter 18, Taxation; Funds; Purchasing; Article I, In General; Section 18-4.1, Service Charge in Lieu of Taxes for Housing Facilities for Certain Persons.

IT IS HEREBY ORDAINED BY PEOPLE OF THE CITY OF FLINT:

Sec. 1. That the provisions of Chapter 18, Taxation; Funds; Purchasing; Article I, In General; Section 18-4.1, Service Charge in Lieu of Taxes for Housing Facilities for Certain Persons, shall be amended by adding subsection (GG), which shall read in its entirety as follows:

(GG) THE CITY ACKNOWLEDGES THAT **FLUSHING PLACE LIMITED DIVIDEND HOUSING ASSOCIATION, LP A LIMITED PARTNERSHIP** (THE "OWNER") HAS OFFERED, SUBJECT TO RECEIPT OF AN AUTHORITY-AIDED OR FEDERALLY-AIDED MORTGAGE LOAN AND/OR ALLOCATION OF LOW INCOME HOUSING TAX CREDITS FROM THE MICHIGAN STATE HOUSING AND DEVELOPMENT AUTHORITY ("MSHDA"), TO OWN AND OPERATE A HOUSING PROJECT IDENTIFIED AS "FLUSHING PLACE" (THE "PROJECT") ON CERTAIN PROPERTY LOCATED IN THE CITY TO SERVE PERSONS AND FAMILIES OF LOW INCOME, AND THAT THE SPONSOR HAS OFFERED TO PAY THE CITY ON ACCOUNT OF THIS HOUSING DEVELOPMENT AN ANNUAL SERVICE CHARGE FOR PUBLIC SERVICES IN LIEU OF AD VALOREM TAXES.

THE CITY ACKNOWLEDGES THAT THE SPONSOR SHALL BE AFFORDED TAX BENEFITS OF PAYING A SERVICE CHARGE

IN LIEU OF AD VALOREM TAXES (BUT NOT IN LIEU OF PAYMENT OF SPECIAL ASSESSMENTS INCLUDING, BUT NOT LIMITED TO, THE STREET LIGHTING SPECIAL ASSESSMENT). THE CITY FURTHER ACKNOWLEDGES THAT THE SPONSOR FITS WITHIN THE CLASS AS DESCRIBED IN §18-4.3 BELOW. THE ANNUAL SERVICE CHARGE FOR THE CLASS OF PERSONS OF LOW AND MODERATE INCOME SHALL BE EQUAL TO FOUR PERCENT (4%) OF THE ANNUAL SHELTER RENTS, EXCLUSIVE OF CHARGES FOR GAS, ELECTRICITY, HEAT, OR OTHER UTILITIES FURNISHED TO THE OCCUPANTS, INCLUDING THE PORTION OF RENT PAYABLE UNDER ANY GOVERNMENTAL SUBSIDY. NOTWITHSTANDING THE FOREGOING, THE ANNUAL SERVICE CHARGE SHALL NOT EXCEED AD VALOREM PROPERTY TAXES THAT WOULD BE ASSESSED OR PAID ABSENT THIS TAX EXEMPTION.

Sec. 2. This ordinance shall become effective immediately upon publication.

Adopted this \_\_\_\_\_ day of

\_\_\_\_\_, 2021 A.D.

\_\_\_\_\_  
Sheldon A. Neeley, Mayor

APPROVED AS TO FORM:

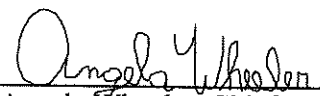
  
\_\_\_\_\_  
Angela Wheeler, Chief Legal Officer

**ORDINANCE REVIEW FORM**

FROM: Planning and Development  
Department

NO. 21- \_\_\_\_\_  
Law Office Login #

ORDINANCE NAME: PILOT ORDINANCE RESOLUTION TO GRANT A FOUR (4%) PAYMENT IN LIEU OF TAXES (PILOT) TO PROJECT ENCOMPASSING SEVERAL PARCELS ON N. STEVENSON, KNOWN AS "FLUSHING PLACE", PROVIDING 60 UNITS OF AFFORDABLE HOUSING TO LOW AND MODERATE INCOME RESIDENTS.

**1. ORDINANCE REVIEW - DEPARTMENT DIRECTOR**

The attached ORDINANCE is approved by the Director of the affected Department. By signing, the Director approves this ordinance to be processed for signatures and fully executed.

By: Director  DATE: March 29, 2021  
Suzanne Wilcox, Director

**2. ORDINANCE REVIEW - LAW DEPARTMENT**

The attached ORDINANCE is submitted to the Legal Department for approval. By signing, the Legal Department approves this ordinance to be processed for signatures and fully executed.

By:  DATE: 3-30-2021  
Angela Wheeler, Chief Legal Officer

**3. ORDINANCE REVIEW-FINANCE DEPARTMENT**

The attached ORDINANCE is submitted to the Finance Department for approval. By signing, the Finance

By:  DATE: 03/30/2021  
Amanda Trujillo, Chief Financial Officer

**4. ORDINANCE REVIEW-MAYORS OFFICE**

The attached ORDINANCE is submitted to the Mayors Office for approval. By signing, the Mayor's office

By: \_\_\_\_\_ DATE: \_\_\_\_\_  
Clyde Edwards, City Administrator

**Flushing Place PILOT Vs. Tax Comparisons**

1) Current taxable generated:	\$3,024	Pilot is based on 4%
2) PILOT estimation	\$18,700.00	DIFFERENCE BETWEEN PILOT AND AD VALOREM TAX
		\$48,828 per year

Based on the Schedule of Rents provided by PK Development., at 100% occupancy, given its rental rates for households at 30%, 40%, and 60% of AMI, the total annual rent potential for the 60 units is \$467,424.

3) Estimated project ad valorum taxable value:

	One Bedroom	Two Bedroom
Market Rent	\$600	\$875
Number of Units	24	36
	<u>\$14,400</u>	<u>\$31,500</u>

Monthly Income	\$45,900
Yearly Income	\$550,800
Vacancy/Loss (10%)	(\$82,620)
Potential Gross Income	<u>\$468,180</u>
Expenses	<u>(\$210,681)</u>
Net Operating Income	\$257,499
Cap Rate of 13%	\$1,980,762
SEV/TV	990,381
Potential Taxes	<u>\$67,528</u>

**PAYMENT IN LIEU OF TAXES  
(PILOT)  
APPLICATION**



**CITY OF FLINT**

1101 S SAGINAW ST.  
FLINT, MI 48502  
TEL: 810-766-7436

## **PURPOSE**

To administer the City of Flint Code of Ordinances 18-4.1 to 18-4.8, establishing a class of housing developments pursuant to the State Housing Development Authority Act of 1966, known as Act 436 of the Acts of 1966, being MCLA §§ 125.1401 et seq. , as amended, which are exempt from property taxes, paying instead a service charge to be paid in lieu of taxes (PILOT) by any or all classes of housing exempt from taxation under this Act at any amount it chooses, but not to exceed the taxes that would be paid for if not for this Act.

The City acknowledges that serving persons of low income is a public necessity, and as such the City of Flint will be benefited and improved by such housing, the encouragement of the same by providing certain real estate tax exemption for such housing is a valid public purpose. The applicant for a PILOT is affirming that the economic feasibility of this housing development is reliant on this requested tax exemption.

Furthermore, in considering this application for PILOT, the evaluators of such request shall consider that the community shall be developed in a manner consistent with the adopted Master Plan and Consolidated Action Plan. Evaluation of the application should take into consideration maintaining the overall goals and objectives set forth in these plans.

## **ELIGIBILITY**

- 1) Applicant must be a nonprofit housing corporation, consumer housing cooperative, limited dividend housing corporation, mobile home park cooperative or mobile home park association, and must be financed with a federally-aided or Michigan State Housing Development Authority (MSHDA) aided mortgage or advance or grant from MSHDA.
- 2) PILOT has been requested during the planning stage of the project; any development project under construction at the time of application is not eligible to apply for, or to receive, a PILOT.
- 3) The applicant must own the property or have an option or other right to purchase the property under consideration and provide in application.
- 4) Housing development must contain a minimum of 51% affordable units.
- 5) Project includes a Low Income Housing Tax Credit (LIHTC) allocation.
- 6) The property is not designated as a Brownfield or 5/50 property or has contacted City to discuss.
- 7) All parcels that are separate have been combined through proper City channels.



## **PROCESS**

1) **Mandatory Pre-Application Conference:** This will be a meeting of all applicable City Departments to include:

- City Administrator
- City Planner
- City Engineer
- City Treasurer
- City Assessor
- Chief Building Official
- Community and Economic Development Staff
- Representatives of applicant development team

This meeting will serve to familiarize all parties with the scope of the project and any issues that may exist. The applicant will also be familiarized with the PILOT process and policies.

2) **Submission of Application:** Application form must be complete and packet of required supporting documentation assembled based upon requirements set forth in the application. Any additional concerns or items that were discussed in the Pre-Application Conference should also be addressed. Application forms are available on both the City of Flint website and in the Department of Community and Economic Development.

One original and one electronic copy shall be submitted no later than seven (7) weeks before the Regular City Council meeting, which are typically held on the 2<sup>nd</sup> and 4<sup>th</sup> Mondays of each month.

3) **Internal (Administrative) Review:** An internal review will occur, resulting in either Administrative approval within three (3) weeks or return to the applicant for corrections.

Applications will be scored on a scoring matrix as attached in this application.

Administrative approval will move the application forward to an ordinance amendment that will be placed on the Government Operation Committee meeting agenda.

4) **Council Committee Review:** Meetings are held the Wednesday prior to the Regular City Council meeting. The developer is required to be in attendance at this meeting to answer any questions the committee may have.

5) **Review by City Council:** Once committee approval is obtained, the ordinance amendment will proceed to the following Regular City Council Meeting (the Monday following committee). The developer is required to be in attendance at this meeting.

6) **Approval:** If the PILOT application is approved by resolution of the City Council, a certified copy of the resolution and a copy of the minutes will be provided to the applicant. Additionally, digital copies will be provided to all applicable City Departments.

***\*Note: All applicants are required to file their MISDA affidavit with the City Assessor by November 1 of the year before the PILOT is to take effect.***

## **APPLICATION REQUIREMENTS**

1) Completed Application Form

2) Narrative:

a. Background information:

- i. Development experience of team
- ii. Describe the corporate partnership structure

b. Describe the proposed Project (include the following sections):

- i. Intended usage/target market
- ii. Economic impact
- iii. Environmental impact (to include any mitigation actions taken)
- iv. Impact on City infrastructure (transportation and utilities)
- v. Impact on City services (police, fire, EMS, code enforcement)
- vi. Square footage of the building and land to be renovated
- vii. Architectural renderings to include the number and type of units
- viii. Any other information to fully explain the project

c. Describe the marketing of the project, clearly identifying the intended market. If the project is speculative, how long is full occupancy expected to take and who will be the property manager?

d. Briefly describe the ownership and tax information for this project:

- i. State the location or the proposed project to include street address, parcel ID, and the legal description.
- ii. Name of the property owner at the time of application.
- iii. If the applicant is not the current owner of record, attach a valid option to purchase.
- iv. Describe any and all financing, options, and liens on the property
- v. State the current assessed value of the property.
- vi. Are any assessments currently under appeal? If yes, describe.

e. Provide a detailed development pro forma outlining proposed hard, soft and financing costs associated with the development. Pro forma must also identify all sources of financing and terms, including Applicant equity, construction, and permanent financing, as well as any government assistance. Proposals must contain detailed cost breakdowns.

f. Provide a detailed operating pro forma. This must include all anticipated major revenues and expenses for the full term of the requested PILOT.

g. Provide a detailed schedule of rents and income limits of lessees

- h. Provide housing market data to show demand.
- i. State a proposed timeline for the Project to include:
  - i. Closing of the loan or contributing financing
  - ii. First expenditure of funds with regards to the project
  - iii. Anticipated date construction will begin
  - iv. Anticipated date of completion
- j. Describe any potential conflicts of interest the applicant or any guarantor may have with any City Personnel or City Council members.
- k. To receive application bonus points, address the following:
  - i. Mixed use (PILOT ONLY applies to housing- not commercial SF)
  - ii. Energy efficiency and green practices
  - iii. Neighborhood and block club outreach (Full list of outreach done)
  - iv. External amenities (walk score, proximity to transit, jobs, etc)
- l. Include a copy of the completed MSHDA application for Low Income Housing Tax Credits (LIHTC) within thirty (30) days of submittal to MSHDA.

(APPLICATION FORM ON NEXT PAGE- ATTACH APPLICATION FORM TO THE REQUIRED NARRATIVES AND SUPPORTING DOCUMENTS)



**PAYMENT IN LIEU OF TAXES (PILOT) APPLICATION**  
**CITY OF FLINT**

**APPLICANT INFORMATION**

<b>ENTITY NAME</b>	Flushing Place LDHA LP
<b>REPRESENTATIVES NAME</b>	Chris Potterpin
<b>ADDRESS</b>	1784 Hamilton Road, Okemos, MI 48864
<b>TELEPHONE NUMBER</b>	517-347-9662
<b>E-MAIL ADDRESS</b>	cpotterpin@pkhousing.com

**GUARANTORS INFORMATION**

<b>ENTITY NAME</b>	PK Companies LLC
<b>ENTITY PRINCIPAL</b>	Chris Potterpin
<b>ADDRESS</b>	1784 Hamilton Road, Okemos, MI 48864
<b>TELEPHONE NUMBER</b>	517-347-9662
<b>E-MAIL ADDRESS</b>	cpotterpin@pkhousing.com

<b>ENTITY NAME</b>	
<b>ENTITY PRINCIPAL</b>	
<b>ADDRESS</b>	
<b>TELEPHONE NUMBER</b>	
<b>E-MAIL ADDRESS</b>	

## **PROJECT INFORMATION**

<b>PROJECT NAME</b>	Flushing Place
<b>ADDRESS OF PROJECT</b>	847, 841, 833, 829, 823 N Stevenson Street, Flint, MI 48504
<b>PARCEL ID</b>	Full parcel ID's and legal descriptions are included in the application narrative.
<b>LEGAL DESCRIPTION</b>	

## **DEVELOPMENT TEAM**

<b>APPLICANT PRIMARY POINT OF CONTACT</b>	Chris Potterpin, PK Companies LLC
<b>ARCHITECTURAL FIRM</b>	Integrated Architecture
<b>CONSTRUCTION PROJECT MANAGER</b>	DW Lurvey Construction Co
<b>GENERAL CONTRACTOR FOR PROJECT</b>	DW Lurvey Construction Co.

*Applicant is to attach items a-l as required in the narrative portion of the application.*

- a. Background information
- b. Project description
- c. Project marketing/target market
- d. Ownership description/tax information
- e. Detailed development pro forma
- f. Operating pro forma
- g. Schedule of rents/income levels
- h. Housing market data supporting demand
- i. Proposed project timeline
- j. Conflicts of interest
- k. Application bonus point items
- l. MSHDA application for LIHTC credits

## Flushing Place PILOT Application Narrative

### *a. Background Info*

- i. Devel experience of team*
- ii. Describe corporate partnership structure.*

The partnership structure for Flushing Place LDHA LP will include both PK Companies LLC and Metro Community Development as co-general partners. Please see the attached PK Companies Resume package for a full overview of our company's development, construction, and management experience.

### *b. Describe Proposed Project*

- i. Intended usage/target market*
- ii. Economic Impact*
- iii. Environmental Impact (include any mitigation actions taken)*
- iv. Impact on City infrastructure (transportation and utilities)*
- v. Impact on City services (police, fire, EMS, code enforcement)*
- vi. Square footage of the building and land to be renovated*
- vii. Architectural rendering to include the number and type of units*
- viii. Any other info to fully explain the project*

Flushing Place is the redevelopment of an entire block along within the University Corridor, bound by Flushing Road, Frost St, Stevenson, and Fifth Ave. The development project will be completed in phases with the first phase being a 9% LIHTC development at the corner of Flushing Road and Stevenson Road. The LIHTC development will include 60-apartment homes for families and individuals in need of affordable housing options in close proximity to community amenities.

The land area of the LIHTC portion of Flushing Place is approximately 1.448 acres or approximately 63,075 square feet. The building area of the LIHTC portion of Flushing Place is approximately 57,580 square feet. Please see the attached drawing and rent roll demonstrating the number and unit types within the Flushing Place LIHTC development.

The intended market for Flushing place is families and individuals in need of quality affordable housing in proximity to employment, goods and services in the city of Flint. The apartment homes will be made available to individuals and families with income at or below 60% of the Area Median Income (AMI), which translates to a maximum of approximately \$30,720 for a two-person household.

Along with the 60 apartment homes under the 9% LIHTC phase of Flushing Place, the project team will also be simultaneously developing an 84-unit market-rate townhouse style project. These new diverse housing opportunities, along with the new commercial and office space for community goods and services will replace a block that has long stood primarily vacant and has been gradually deteriorating. The construction of the development itself is anticipated to create around 150 jobs, while the new commercial and office space could create several new permanent employment positions.

A Phase I environmental study is being commissioned by PM Environmental. The report will detail any contamination or required remediation activity for the site. Once complete, the Flushing Place block will

resolve any existing environmental concerns or abatement. There are no uses planned for the site that will result in any future adverse environmental impacts.

The development of Flushing Place will include significant investment in site infrastructure, as well as upgrades to tie-ins and infrastructure located in the road right-of-way surrounding the development.

Flushing Place is expected to alleviate demand for city services as they relate to blighted and vacant property. The development of Flushing Place will bring additional site security reducing the need for visits by Police and Fire departments. Creating a vibrant neighborhood with Flushing Place will reduce the amount of crime that occurs in this area.

- c. *Describe the marketing of the project, clearly identifying the intended market. If the project is speculative, how long is full occupancy expected to take and who will be the property manager*

Marketing for the finished apartment homes will follow an Affordable Fair Housing Marketing Plan (attached as an exhibit) as required by the MSHDA LIHTC program. This plan will be carried out by PK Housing & Management, an affiliate of PK Development Group (member of PK Metro Flushing Place LDHA LP). We expect to reach full occupancy within 8 months of completing construction.

- d. *Briefly describe the ownership and tax info for this project:*
- i. *State the location of the proposed project to include street address, parcel ID and the legal description*
  - ii. *Name of the property owner at the time of application*
  - iii. *If the applicant is not the current owner of record, attach a valid option to purchase*
  - iv. *Describe any and all financing, options, and liens on the property*
  - v. *State the current assessed value of the property*
  - vi. *Are any assessments currently under appeal? If yes, describe.*

The Flushing Place project site is bound by Flushing Road, University Ave, Frost Street, and Stevenson Road. The redevelopment of this block will occur over several phases. For purposes of this application, the first phase, also the 9% LIHTC phase, will be constructed on the corner of Flushing Road and Stevenson Road. The street addresses, parcel numbers, current ownership entities, current assessed values, and legal descriptions are listed below:

- 841 N Stevenson Street (Parcel ID: 40-12-358-038)  
Current Owner: DFPH, LLC  
Assessed Value: \$123,200  
Legal Description:  
LOTS 16 AND 17, BLK A OF A. MCFARLAN'S REPLAT OF PARTS OF BLOCK 3, MCFARLAN & CO.'S COTTAGE GROVE ADDITION EXC BEG AT THE SE'LY COR OF SD LOT 17; TH N'LY TO THE LT ALONG A 30 DEG 49 MIN CURVE TO A PT ON N LINE OF SD LOT 16, 17.9 FT W OF W LINE OF STEVENSON ST; TH E'LY 17.9 FT ALONG SD N LINE TO W LINE OF STEVENSON ST; TH S'LY TO POB; ALSO EXC BEG ON THE N LINE OF SD LOT 16, 17.9 FT W OF THE NE COR OF SD LOT; TH W ALONG SD N LINE 81.8 FT; TH S 30 DEG 0 MIN E 0.66 FT; TH E'LY 81.81 FT TO POB; ALSO LOT 17, BLK 3 EXC S'LY 26 FT OF MCFARLAN & CO.'S COTTAGE GROVE ADDITION.

- 847 N Stevenson Street (Parcel ID: 40-12-358-052)  
 Current Owner: DFPH, LLC  
 Assessed Value: \$70,300  
 Legal Description:  
 A. MCFARLAN'S REPLAT OF PARTS OF BLOCK 3, MCFARLAN & CO.'S COTTAGE GROVE ADDITION LOTS 13 AND 14; ALSO LOT 15 EXC BEG AT A PT ON NLY LINE OF SD LOT, 0.1 FT ELY FROM NWLY COR OF SD LOT; TH SELY ALG A 30 DEG 49 MIN CURVE TO THE RIGHT TO A PT ON SLY LINE OF SD LOT, 17.9 FT WLY FROM SELY COR OF SD LOT; TH ELY ALG SD SLY LINE 17.9 FT TO SD SELY COR; TH NLY ALG ELY LINE 28.3 FT TO NELY COR OF SD LOT; TH WLY ALG NLY LINE OF SD LOT, 108.4 FT TO POB; ALSO PART OF LOT 16 DESC AS: BEG AT A PT ON NLY LINE OF SD LOT, 17.9 FT WLY FROM NELY COR OF SD LOT; TH WLY ALG SD NLY LINE, 81.80 FT; TH SLY = WITH ELY LINE OF SD LOT, 0.66 FT; TH ELY 81.81 FT TO POB, BLK A
  
- 823 Stevenson Street (Parcel ID: 40-12-358-041)  
 Current Owner: Arif, Ahmed A  
 Assessed Value: \$13,900  
 Legal Description:  
 MCFARLAN & CO.'S COTTAGE GROVE ADDITION LOT 15, BLK 3
  
- 829 Stevenson Street (Parcel ID: 40-12-358-040)  
 Current Owner: Hughes, Anna & Husna, Arif  
 Assessed Value: \$2,800  
 Legal Description:  
 MCFARLAN & CO.'S COTTAGE GROVE ADDITION SLY 48 FT OF LOT 16, BLK 3
  
- 833 Stevenson Street (Parcel ID: 40-12-358-039)  
 Current Owner: Husna Arif Properties, LLC  
 Assessed Value: \$15,000  
 Legal Description:  
 MCFARLAN & CO.'S COTTAGE GROVE ADDITION NLY 18 FT OF LOT 16, ALSO SLY 26 FT OF LOT 17, BLK 3

The project team is currently resolving final negotiations for Purchase Option Agreements on each of the aforementioned properties. Current drafts of these agreements are attached. Aside from these agreements, there are no other options, financing, or liens on the property, nor any assessments under appeal.

- e. Provide a detailed development proforma outlining proposed hard, soft and financing costs associated with the development. Pro forma must also identify all sources of financing and terms, including applicant equity, construction, and permanent financing, as well as any government assistance. Proposals must contain detailed cost breakdowns.*

Please see the attached development sources and uses.

- f. Provide a detailed operating pro forma. This must include all anticipated major revenues and expenses for the full term of the requested PILOT.*



Please see the attached operating proforma.

- g. Provide a detailed schedule of rents and income limits of lessees.*

Please see the attached rent roll and income limits.

- h. Provide housing market data to show demand.*

A full market study for Flushing Place is currently being commissioned by Bowen National Research, as required by MSHDA for a LIHTC application. The market study report will be shared with the City of Flint once complete.

- i. State a proposed timeline for the Project to include:
  - i. Closing of the loan or contributing financing.*
  - ii. First expenditure of funds with regards to the project.*
  - iii. Anticipated date construction will begin*
  - iv. Anticipated date of completion**

Closing on the construction loan for Flushing Place will occur by the fourth quarter 2021, with construction commencing at that same time. The project team has already begun expenditure of funds with due diligence work including land acquisition, environmental investigation, site planning and design work. We anticipate the construction will be complete by September of 2022.

- j. Describe any potential conflicts of interest the applicant or any guarantor may have with any City Personnel or City Council members.*

There are no conflicts of interest between the applicant, it's guarantors, and City Personnel or City Council members.

- k. To receive application bonus points, address the following:
  - i. Mixed- use (PILOT ONLY applies to housing, not commercial SF)*
  - ii. Energy efficiency and green practices*
  - iii. Neighborhood and block club outreach (full list of outreach done)*
  - iv. External amenities (walkscore, proximity to transit, jobs, etc)**

The development will include a 5-story mixed use building on the corner of Flushing and Stevenson. This building will include approximately 60 apartment homes as well as 3,800 square feet of first floor commercial space.

The construction and development of the Flushing Place project will follow and adhere to Enterprise Green Building Standards for certification within that program as a new construction project.

The PK-Metro team has been very active in engaging stakeholders before moving forward with this project. We have presented plans and received input from the Mott Foundation, Genesee County Land Bank, Kettering University, and Hurley Hospital. We have worked diligently to refine and improve this project with the helpful input from each of our meetings. In addition, the project team has relied heavily on work done by the neighborhood group to envision the redevelopment of this land – Flushing Place seeks to drive that vision forward.

While the walkscore for the property is on the low end with a score of 42, due to the project location upon the University Avenue Corridor, there are several MTA bus stops within close walking distance of Flushing Place. This proximity to transportation will enable residents to access many nearby community amenities that may be just out of walking distance, as well as the downtown core of the city. There are many employment opportunities within close proximity, with large employers such as the Hurley Medical Center to the east and Kettering University to the west.

- 1. Include a copy of the completed MSHDA application for LIHTC within 30 days of submittal to MSHDA.*

A copy of the Flushing Place LIHTC application will be provided to the City of Flint once it has been submitted to MSHDA.

PK Development Group  
Sources and Uses  
Flushing Place - Mixed Use  
Flint, MI

Sources	Construction	Permanent	Housing TC Acq Basis	Housing TC Rehab Basis	Amortized	Other
Interim Loan		-				
Construction Loan #1		-				
Housing Credit Equity	3,736,188	12,453,960				
Construction / Perm Loan #1	9,503,981	2,000,000				
Construction / Perm Loan #2	-	-				
Construction / Perm Loan #3	-	-				
Developer Equity	-	-				
GP Loan	-	-				
Mott Investment	-	-				
Grant #2	-	-				
Reserves Transferred						
Historic Tax Credit Equity						
Deferred Developer Fee	1,125,000	178,061				
Cash from Operations						
<b>Total Sources</b>	<b>14,365,169</b>	<b>14,632,021</b>				
<b>Uses</b>						
<i>Acquisition Costs</i>						
Acquisition - Cash	625,000					62,500
Acquisition - Debt Assumed	-					-
Acquisition Soft Costs	-					-
<i>Hard Costs</i>						
Building Costs - Residential	8,700,000			8,700,000		
Building Costs - Townhouses	-			-		
Site Work	1,475,000			1,475,000		
Contractor Profit & Fees	-			-		
Retail TI	120,000			-		
FF&E, Owner Items	-			-		
Contingency	508,750			508,750		
<i>Soft Costs</i>						
Architect & Engineering Fees	486,169			415,692		
Real Estate Legal	35,000			29,926		
Survey	10,500			8,978		
Capital Needs Assessment	-			-		
Appraisal	5,000			4,275		
Environmental	30,000			25,651		
Title, Recording, Taxes	50,000			42,752		
Builder's Risk & GL Insurance	30,000			25,651		
Real Estate Taxes	-			-		
Payment & Performance Bond	-			-		
Construction Interest	371,250			158,716		212,534
Interim Loan Fees	110,000			94,054		
Interim Lender Legal	30,000			25,651		
Accounting	20,000			20,000		
Relocation Costs/Marketing	15,000			-		
Developer Fees	1,500,000			1,500,000		
Market Study	6,000			6,000		
Tax Exempt Bond COI & Interest	-			-		
Soft Cost Contingency	75,000			64,128		
Permanent Loan #1 Fees		27,500			27,500	
Permanent Loan #1 Legal		15,000			15,000	
Permanent Loan #2 Fees		-			-	
Permanent Loan #2 Legal		-			-	
Syndicator Legal		-			-	
Tax Credit fees	112,500					112,500
Other Soft Cost #1						-
Other Soft Cost #2						-
Other Soft Cost #3						-
Leaseup Reserve	50,000					50,000
Operating Reserve (6 mos)		224,352				224,352
Replacement Reserve		-				-
Repair Escrow		-				-
<b>Total Uses</b>	<b>14,365,169</b>	<b>14,632,021</b>	<b>-</b>	<b>13,105,225</b>	<b>42,500</b>	<b>661,886</b>

LIHTC Allocation % 0.86

PK Development Group  
 Summary Proforma  
 Flushing Place - Mixed Use  
 Flint, MI

Construction

	Base Year 20%							
	1	2	3	4	5	6	7	8
	2022	2023	2024	2025	2026	2027	2028	2029
Gross Rent Potential - Residential	467,424	467,424	476,772	486,308	496,034	505,955	516,074	526,395
Gross Rent Potential - Commercial	17,951	18,000	18,360	18,727	19,102	19,484	19,873	20,271
Commercial Reimbursement	16,953	17,000	17,510	18,035	18,576	19,134	19,708	20,299
Vacancy - Residential	(377,334)	(93,485)	(33,374)	(34,042)	(34,722)	(35,417)	(36,125)	(36,848)
Vacancy - Commercial	-	(1,800)	(1,836)	(1,873)	(1,910)	(1,948)	(1,987)	(2,027)
Other Income	-	-	-	-	-	-	-	-
<b>Total Revenue</b>	<b>124,994</b>	<b>407,139</b>	<b>477,432</b>	<b>487,156</b>	<b>497,080</b>	<b>507,207</b>	<b>517,542</b>	<b>528,090</b>
Administrative and Office Expense	12,534	25,000	25,750	26,523	27,318	28,138	28,982	29,851
Audit and Tax Return	6,016	12,000	12,360	12,731	13,113	13,506	13,911	14,329
Management Fees	33,840	33,840	34,855	35,901	36,978	38,087	39,230	40,407
Utilities - Gas	9,025	18,000	18,540	19,096	19,669	20,259	20,867	21,493
Utilities - Water and Sewer	25,068	50,000	51,500	53,045	54,636	56,275	57,964	59,703
Utilities - Electric	9,025	18,000	18,540	19,096	19,669	20,259	20,867	21,493
Elevator	5,014	10,000	10,300	10,609	10,927	11,255	11,593	11,941
Maintenance and Grounds	16,044	32,000	32,960	33,949	34,967	36,016	37,097	38,210
Commercial Taxes	6,016	12,000	12,360	12,731	13,113	13,506	13,911	14,329
Commercial Insurance	2,507	5,000	5,150	5,305	5,464	5,628	5,796	5,970
Marketing/Leasing	-	-	-	-	-	-	-	-
Property Taxes - 4% PILOT	6,440	12,846	15,554	15,837	16,124	16,417	16,714	17,016
Insurance	7,521	15,000	15,450	15,914	16,391	16,883	17,389	17,911
Payroll	32,589	65,000	66,950	68,959	71,027	73,158	75,353	77,613
	171,639	308,686	320,269	329,693	339,397	349,387	359,673	370,265
<b>Net Operating Income</b>	<b>(46,645)</b>	<b>98,454</b>	<b>157,163</b>	<b>157,463</b>	<b>157,683</b>	<b>157,820</b>	<b>157,869</b>	<b>157,826</b>
Replacement Reserve Funding	-	4,500	18,540	19,096	19,669	20,259	20,867	21,493
Perm Loan #1 Payment	-	27,474	109,895	109,895	109,895	109,895	109,895	109,895
Perm Loan #2 Payment	-	-	-	-	-	-	-	-
Leaseup Reserve w/d	(35,000)	-	-	-	-	-	-	-
<b>Net Cash Flow</b>	<b>(11,645)</b>	<b>66,480</b>	<b>28,729</b>	<b>28,472</b>	<b>28,119</b>	<b>27,666</b>	<b>27,108</b>	<b>26,438</b>
DSCR - Hard Loans			1.26	1.26	1.26	1.25	1.25	1.24

PK Development Group  
 Summary Proforma  
Flushing Place - Mixed Use  
Flint, MI

	9 2030	10 2031	11 2032	12 2033	13 2034	14 2035	15 2036
Gross Rent Potential - Residential	536,923	547,662	558,615	569,787	581,183	592,807	604,663
Gross Rent Potential - Commercial	20,676	21,090	21,512	21,942	22,381	22,828	23,285
Commercial Reimbursement	20,908	21,535	22,181	22,847	23,532	24,238	24,965
Vacancy - Residential	(37,585)	(38,336)	(39,103)	(39,885)	(40,683)	(41,496)	(42,326)
Vacancy - Commercial	(2,068)	(2,109)	(2,151)	(2,194)	(2,238)	(2,283)	(2,328)
Other Income	-	-	-	-	-	-	-
Total Revenue	538,855	549,841	561,054	572,496	584,175	596,094	608,258
Administrative and Office Expense	30,747	31,669	32,619	33,598	34,606	35,644	36,713
Audit and Tax Return	14,758	15,201	15,657	16,127	16,611	17,109	17,622
Management Fees	41,619	42,867	44,154	45,478	46,842	48,248	49,695
Utilities - Gas	22,138	22,802	23,486	24,190	24,916	25,664	26,434
Utilities - Water and Sewer	61,494	63,339	65,239	67,196	69,212	71,288	73,427
Utilities - Electric	22,138	22,802	23,486	24,190	24,916	25,664	26,434
Elevator	12,299	12,668	13,048	13,439	13,842	14,258	14,685
Maintenance and Grounds	39,356	40,537	41,753	43,005	44,295	45,624	46,993
Commercial Taxes	14,758	15,201	15,657	16,127	16,611	17,109	17,622
Commercial Insurance	6,149	6,334	6,524	6,720	6,921	7,129	7,343
Marketing/Leasing	-	-	-	-	-	-	-
Property Taxes - 4% PILOT	17,323	17,636	17,954	18,277	18,605	18,939	19,279
Insurance	18,448	19,002	19,572	20,159	20,764	21,386	22,028
Payroll	79,942	82,340	84,810	87,355	89,975	92,674	95,455
	381,169	392,397	403,958	415,861	428,117	440,736	453,730
Net Operating Income	157,686	157,444	157,096	156,635	156,058	155,357	154,528
Replacement Reserve Funding	22,138	22,802	23,486	24,190	24,916	25,664	26,434
Perm Loan #1 Payment	109,895	109,895	109,895	109,895	109,895	109,895	109,895
Perm Loan #2 Payment	-	-	-	-	-	-	-
Leaseup Reserve w/d	-	-	-	-	-	-	-
Net Cash Flow	25,654	24,748	23,715	22,550	21,247	19,799	18,200
DSCR - Hard Loans	1.23	1.23	1.22	1.21	1.19	1.18	1.17



Project: Flushing Place Apartments  
Flint, MI

The following information is being submitted as the Affirmative Fair Housing Marketing Plan for Flushing Place Apartments located in Flint, Michigan. Flushing Place is an affordable senior community that will operate with the funding provided by low income housing tax credits.

The intent of this document is to define what minority populations exist within the community and to outline the methods which will be used by PK Housing & Management to make these groups aware of the opportunity for them to reside at Flushing Place Apartments.

Flushing Place Apartment's Primary Market Area (PMA) consists of The City of Flint and Genesee County. For purposes of this report, Genesee County 2019 estimated census data is utilized. According to the census data, there was an estimated 405,813 people in the Primary Market area; of this group 13.4% were disabled and 28.3% were minority. The minority population consists of 20.3% black, 0.6% American Indian or Alaska Native, 1% Asian, 2.8% reporting two or more races, and 3.6% Hispanic or Latino. The target population least likely to apply for housing at Flushing Place Apartments is the minority and handicap population. The goal of PK Housing is to market at least 17 units of the total 60 units in the project to minority individuals and 8 units to disabled individuals. PK Housing and Management will make a concentrated effort through advertising, community outreach, and staff orientation and training using the methods outlined in the attached training schedule to accomplish this goal.

The community outreach portion of the Affirmative Marketing Plan will center round personal contact and written correspondence with business and industry, governmental agencies, and influential members of the minority/handicap population of the community. Chief operating officers of governmental agencies who deal with minority/handicap group members will be personally contacted and their assistance in reaching this target population will be solicited. Follow-up contact will be via letter/brochure describing the apartments and amenities. A partial list of these groups along with their addresses and telephone numbers are included as Exhibit B.

The method used to initiate contact with minority group members will be threefold and begin 120 days before the first units are released: newspaper, community outreach (business and industry); governmental agencies; contact with community groups whose membership is either primarily composed of minorities, or at least heavily represented by that segment of the population, and contact with well-known and/or influential individuals within the minority community itself.

The Regional Property Manager that will be responsible for supervising the marketing of Flushing Place Apartments and is responsible for the training and achievement of the Affirmative Marketing and Handicap Marketing goals. The Marketing Staff will meet as a group at least once a week to discuss individual prospects they have met. Each member will be instructed to take special note of all applicants who contact him or her, and to record after that person leaves his/her attitude toward the project in general, and the degree of interest in any specific unit. Staff members will be required to read the Affirmative Marketing Plan as a prerequisite to working at Flushing Place Apartments. Additionally, they will be asked to query all applicants as to how they heard about the apartments. This information will be continually evaluated so the advertising effort can be more effective.

PK Housing & Management's approach toward media advertising to attract members of minority groups will center on newspaper and flyer/brochure mailings. The largest newspaper in the area is the Flint Journal. The newspaper's readership is within the Primary Market Area. The classified section will be utilized weekly during the initial marketing of the project.

A flyer/brochure will be developed for Flushing Place Apartments if needed. The brochure will indicate location in relation to community amenities, unit layout, information on appliances, and will contain all necessary slogans and logos. The brochure as well as all advertising will contain the words "Equal Housing Opportunity" and logo as well as the wheelchair logo.

The Affirmative Marketing Plan and Handicap Marketing Plan are plans that are in place for the life of the mortgage, constructed to accomplish marketing of Flushing Place Apartments to a representative minority and handicap populations. If, after marketing efforts have begun, it is perceived that these goals can be better achieved by

advertising with different or additional agencies or individuals, these plans will be flexible enough to be changed and/or expanded.

The following is a breakdown of the overall annual marketing budget for Flushing Place Apartments. The portion of expenses utilized to implement this Affirmative Marketing Plan are noted.

Item	Affirmative Marketing	General	Total
Brochure/Flyers	\$156	\$446	\$602
Stationary	\$46	\$132	\$178
Newspaper	\$291	\$822	\$1,113
Signage	\$29	\$90	\$119
Open House	\$85	\$241	\$326
Postage	\$73	\$207	\$280
Staff	\$230	\$652	\$882
<b>TOTAL</b>	<b>\$910</b>	<b>\$2,590</b>	<b>\$3,500</b>

PK Housing & Management, as a Managing Agent, specializes in the management of subsidized housing that has been constructed under the HUD, MSHDA and Rural Development programs. All advertising contains the wheelchair logo to aid in achieving our handicapped goals. PK Housing & Management has been able to reach its Affirmative Marketing and Handicap goals on projects all over the state of Michigan, as well as Texas, Indiana, and Ohio to maintain its compliance with various funding programs.

PK Housing and Management also agrees to comply with the following requirements:

1. That a continuous outreach program will be conducted to maintain a well-balanced waiting list that will assure the meeting of the affirmative marketing goal at all times.
2. That a housing discrimination disclaimer clause shall be included in any preliminary and/or full application blank. (Pledge not to discriminate against applicants based on their race, sex, age, religion, national origin, familial status, or handicap.)
3. That the handicap logo will be in all advertisements, if the development has barrier free or accessible units.
4. That the MSHDA approved equal opportunity housing slogan or logo will be included in all advertising.
5. That a log of community contacts, daily traffic records, and any other record keeping materials be maintained for inspection and a copy of the AFHMP will be kept on site.
6. That all fair housing required signs will be posted in designated locations.
7. That the management agent, PK Housing and Management, has agreed to start the Affirmative Fair Housing Marketing efforts with respect to the "target population" at least 120 days prior to anticipated initial occupancy.
8. That any prospective residential preferences will be identified and made known.

\_\_\_\_\_  
Signature  
  
\_\_\_\_\_  
Ronald Potterpin  
Print Name

\_\_\_\_\_  
January 5, 2021  
Date  
  
\_\_\_\_\_  
President  
Title



## PK Housing & Management - Staff Training Schedule

PK Housing & Management has one annual training per year for its staff and Fair Housing is always a topic at our annual training.

In addition, Administrative and Site Management staff is required to take and pass Fair Housing I, Fair Housing II, and Preventing Sexual Harassment provided by Grace Hill; Essential Multifamily Educators online education annually. See listing below.

Maintenance staff is required to take and pass Fair Housing for Maintenance provided by Grace Hill online educators annually.

Other Fair Housing Training Seminars are also sought for additional training at all levels of our personnel.

**Flushing Place Apartments  
Exhibit B**

Flint Housing Commission  
3820 Richfield Rd  
Flint, MI 49506  
810-736-3050  
Fax 810-736-0158  
Director: Harold Ince, Jr.

The Disability Network  
3600 Dort Hwy #54  
Flint, MI 48507  
810-742-1800  
Director: Duncan Beagle

Family Service Agency of Mid Michigan  
1422 West Court Street  
Flint, MI 48503  
801-767-4014 ext. 419  
Director: Brooke Gow

Spectrum Human Services  
711 Saginaw St  
Flint, MI 48503  
734-458-8736  
Director: Barbara Fowkes

## OPTION AGREEMENT

This Option Agreement, entered into this \_\_\_\_ day of October, 2020, between **UPTOWN REINVESTMENT CORPORATION**, a Michigan nonprofit corporation, of 503 S. Saginaw Street, Suite 1500, Flint, MI 48502 (hereinafter "Optionor"), and **PK DEVELOPMENT GROUP LLC** (or its assignee), a Michigan limited liability company, of 1784 Hamilton Road, Okemos, MI 48864 and **METRO COMMUNITY DEVELOPMENT**, a Michigan nonprofit corporation, of 503 S. Saginaw Street, Suite 804, Flint, MI 48502 (hereinafter the "Optionee"), is entered for the purpose of giving the Optionee exclusive rights to purchase the property described on Exhibit A ("Property"), pursuant to the Flushing Place Development Plan demonstrated by Exhibit B ("Development Plan").

1. **Term of Option.** This Option for the Property is effective from the date set forth above until the 1<sup>st</sup> day of \_\_\_\_\_, 20\_\_.

2. **Earnest Money Deposit.** Optionee shall deposit in escrow with Cinnaire Title Services, LLC (the "Title Company") the sum of Five Thousand and No/100 (\$5,000.00) Dollars cash, deposited within five (5) Business Days (as defined below) of the Effective Date (the "Initial Earnest Money Deposit"). The Earnest Money Deposit shall be held in a non-interest bearing account. The Earnest Money Deposit shall be credited to the Purchase Price at closing and shall be non-refundable upon expiration of the last to expire of the contingency periods except as otherwise specifically provided. For purposes hereof, the phrase "Business Days" shall mean the days of the week other than Saturday, Sunday, or a day on which banking institutions in Detroit, Michigan are obligated or authorized by law or executive action to be closed to the transaction of normal banking business.

3. **Escrow Agent.** The Escrow Agent shall be Cinnaire Title Services LLC of 1118 S. Washington Avenue, Lansing, MI 48910.

4. **Method of Exercising Option.** To exercise this Option, the Optionee shall notify the Optionor in writing that it is exercising the Option, and shall either personally deliver to or mail by certified mail, return receipt requested, such notice to the Optionor. To be effective, said notice must be sent by the Optionee on or before the expiration date of this Option.

5. **Terms of Agreement.** Optionor and Optionee hereby agree to the following terms upon which this Option shall be contingent:

- A. **Tax Credits and Financing.** The obligations of Optionee hereunder are subject to Optionee's successful obtainment of LIHTC credits upon terms and conditions satisfactory to Optionee, in Optionee's sole discretion. Subject to securing the required PILOT, which shall be diligently pursued, Optionee shall timely submit its initial application to the Michigan State Housing Development Authority ("MSHDA") for the February 2021 funding round and shall diligently pursue such application. The obligations of Optionee hereunder are further subject to Optionee's prospective lender receiving an acceptable appraisal report.

- B. Optionee shall timely submit its initial application to the Michigan State Housing Development Authority (“MSHDA”) for the February 2021 funding round and shall diligently pursue such application.

6. **Warranties and Representations.**

A. **Mutual Representations.** Each party represents and warrants to the other that: (1) it has full power and authority to enter into this Agreement and consummate the transactions contemplated by this Agreement; and (2) all necessary actions have been taken to authorize the signatories herein to execute and deliver this Agreement and the other documents and instruments contemplated by this Agreement.

B. **Inducement.** Each party makes the representations and warranties made by it in order to induce the other to enter into this Agreement.

C. **Optionor's Representations and Warranties.** Optionor represents and warrants that each of the following are true as of the Effective Date and will be true as of the date of Closing and makes these representations and warranties with the understanding that each of said representations and warranties is material, notwithstanding any investigations, inspections or examinations made by or on behalf of Optionee, and has been relied upon by Optionee in connection herewith and shall survive the Closing of any sale made pursuant to this Agreement and the delivery of the warranty deed and other closing documents. Optionor shall indemnify, defend and hold Optionee and its members, partners, officers, directors, employees and agents harmless from and against any and all claims, demands, liabilities, costs, expenses, penalties and damages, (including reasonable attorneys' fees) arising out of, resulting or related in any manner to a breach of any of these representations and warranties by Optionor. Optionee may not make a claim hereunder using any fact or event which is inconsistent with any representation or warranty, which fact or event it obtains actual knowledge prior to closing as a result of its due diligence or otherwise.

1. **Litigation.** Optionor has no actual knowledge of any litigation, claim, governmental proceeding or investigation of any kind or nature pending or threatened, or any orders, judgments of any court relating to Optionor or the Property, or against Optionor's title to or right to possess the Property and Optionor has no knowledge or reason to believe that anyone other than Optionor has any interest or right whatsoever in the Property, except as disclosed in the title commitment.

2. **Other Claims.** Except as otherwise disclosed to Optionee on the Title Commitment, Optionor has received no notice and has no knowledge of any condemnation or regular or special assessment, or proceeding concerning same, affecting either the whole or any part of the Property, and no federal, state or local taxing authority has asserted any tax deficiency, lien or assessment against the Property or Optionor or any officers of Optionor.

3. **Environmental Status.** To the best of Optionor's knowledge, except with respect to the asbestos flooring, which has been encapsulated, Optionor has not received any notice from any applicable governmental entity or to the best of

Optionor's knowledge any other person of the potential or actual existence of any hazardous material on, in, under or otherwise affecting the Property.

4. Construction Liens. Optionor represents and warrants that it has no knowledge of any claim for construction liens or of work done from which a construction lien could arise, and that all work done on the Property that could result in a construction lien has been paid or will be paid.

5. Ownership. To the best of Optionor's knowledge, it is the fee owner of the Property. Optionor has not granted, and shall not grant prior to closing, any option or rights of first refusal to third parties to acquire or purchase any interest in any of the Property that may impede Optionor's performance under this Agreement or remain outstanding after the Closing.

6. Bankruptcy. As of the Effective Date, there are no attachment, execution or assignment for the benefit of creditors or voluntary proceedings in bankruptcy or under other debtor relief law pending, contemplated by, or (to Optionor's knowledge) threatened against Optionor, or otherwise affecting all or any of the Property, other than any such action against an individual tenant. Optionor will, at closing, reaffirm this representation.

7. Condemnation. Optionor has not received any notice and has no actual knowledge of any pending or threatened condemnation or similar proceeding affecting any of the Property, or any pending public improvements in or adjoining any of the Property that could in any manner affect any of the Property.

8. Right to Possession. To the best of Optionor's knowledge, no person, firm, or corporation has a right to possession or is in possession of the Property or any portion thereof, as a lessee or tenant of Optionor or otherwise except as shown on the leases, rent roll and title report.

9. Optionor is not a foreign person as defined in Section 1445(f) (3) of the Internal Revenue Code and Regulations promulgated thereunder, which Optionor shall so certify at Closing.

Whenever a representation is qualified by the phrase "to Optionor's best knowledge" or by words of similar import, the accuracy of such representation shall be based solely on the actual knowledge without independent investigation or inquiry.

D. Optionee's Representations and Warranties. Optionee represents and warrants that each of the following are true as of the Effective Date and will be true as of the date of Closing and makes these representations and warranties with the understanding that each of said representations and warranties is material, notwithstanding any investigations, inspections or examinations made by or on behalf of Optionor, and has been relied upon by Optionor in connection herewith and shall survive the Closing of any sale made pursuant to this Agreement and the delivery of the warranty deed and other closing

documents, but shall be subject to the limitations set forth in Section 7.2 above. Optionee shall indemnify, defend and hold Optionor and its members, partners, officers, directors, employees and agents harmless from and against any and all claims, demands, liabilities, costs, expenses, penalties and damages, (including reasonable attorneys' fees) arising out of, resulting or related in any manner to a breach of any of these representations and warranties by Optionee. Optionor may not make a claim hereunder using any fact or event which is inconsistent with any representation or warranty, which fact or event it obtains actual knowledge prior to closing as a result of its due diligence or otherwise.

1. Authority. Neither the execution and delivery of this Agreement nor the consummation of the transactions contemplated hereby will: (i) be in violation of Optionee's organizational documents; (ii) conflict with or result in a breach of any law, regulation, writ, injunction or decree of any court or governmental instrumentality applicable to Optionee; or (iii) constitute a breach of any agreement to which Optionee is a party or by which Optionee is bound.

2. OFAC. Each of Optionee and those persons and entities having any direct or indirect ownership interest in Optionee is: (i) not a "blocked" person listed in the Annex to Executive Order Nos. 12947, 13099 and 13224 and all modifications thereto or thereof (as used herein, the "Annex"); (ii) in full compliance with the requirements of the Patriot Act and all other requirements contained in the rules and regulations of the Office of Foreign Assets Control, Department of the Treasury ("OFAC"); (iii) operated under policies, procedures and practices, if any, that are in compliance with the Patriot Act; (iv) not in receipt of any notice from the Secretary of State or the Attorney General of the United States or any other department, agency or office of the United States claiming a violation or possible violation of the Patriot Act; (v) not listed as a "Specially Designated Terrorist" or as a "blocked" person on any lists maintained by the OFAC pursuant to the Patriot Act or any other list of terrorists or terrorist organizations maintained pursuant to any of the rules and regulations of the OFAC issued pursuant to the Patriot Act or on any other list of terrorists or terrorist organizations maintained pursuant to the Patriot Act; (vi) not a person who has been determined by competent authority to be subject to any of the prohibitions contained in the Patriot Act; and (vii) not owned or controlled by or now acting and or will in the future act for or on behalf of any person named in the Annex or any other list promulgated under the Patriot Act or any other person who has been determined to be subject to the prohibitions contained in the Patriot Act. All capitalized words and phrases and all defined terms used in the USA Patriot Act of 2001, 107 Public Law 56 (October 26, 2001) and in other statutes and all orders, rules and regulations of the United States government and its various executive departments, agencies and offices related to the subject matter of the Patriot Act, including Executive Order 13224 effective September 24, 2001 (collectively referred to as the "Patriot Act") are incorporated into this Section.

7. Contents of Real and Personal Property. Optionor shall retain ownership of all contents of the structures located on the Property and any personal property therein. Any contents or personal property left on the property when Optionee takes possession shall be considered

abandoned by Optionor. Optionor acknowledges that the structures will be demolished by Optionee shortly after closing and Optionor agrees to hold Optionee harmless for any loss of contents of the structures or personal property located on the Property when Optionee takes possession.

8. **Title**. Upon the execution of this Option Agreement, the Optionor shall have fifteen (15) days to provide a title commitment from the Escrow Agent in the amount of the Purchase Price insuring title in a form acceptable to Optionee. Optionor shall provide a fee simple title policy at closing and shall pay for the cost of said policy. If Optionor cannot provide marketable or insurable title, and/or the right to lease the Property in a form acceptable to Optionee, then Optionee shall be entitled to void this agreement.

8. **Assignment**. The Optionee has the sole right to assign this Option to any entity designated by Optionee without Optionor's consent.

9. **Taxes and Assessments**. All real estate taxes to date, shall be prorated as of date of Closing.

10. **Optionee's Right to Rezone**. Optionor agrees that the Optionee shall have the right during the Option period to apply for whatever municipal approvals are necessary to utilize the property for its intended use and that the Optionor shall support, and cooperate with any such approvals by Optionee.

11. **Site Inspection Rights**: Upon reasonable notice to Optionor, Optionee, and Optionee's agents, employees, contractors and consultants, shall have access to the Property to conduct such inspections, investigations, appraisals, tests and determinations of the Property as Optionee shall desire in order to determine, in Optionee's sole opinion, that the condition of the Property is acceptable and that the Property is suitable for Optionee's intended use. The cost of any and all such inspections, investigations, appraisals, tests and determinations shall be paid by the Optionee. Any report obtained shall be kept confidential and disclosed only to those necessary to effect this transaction. In the event Optionee discovers an environmental condition to which it objects, Optionee shall notify Optionor of such objection. Optionor shall have the right, but not the obligation, to correct such objection within thirty (30) days of notice of such objection which correction may be acceptable to Optionee in its sole discretion.

Optionee and its agents, employees and independent contractors shall have an irrevocable license and right to enter upon the Property during normal business hours after at least 48 hours prior notice to Optionor, for engineering, inspection and other purposes, including, but not limited to, feasibility studies, environmental inspections, the establishment of boundaries, the examination of any and all utilities and/or mechanical devices or equipment contained on the Property and the examination of the interior of and exterior to buildings and such other investigations as Optionee's lender may require. All such entries shall be at the risk of Optionee and its agents, employees and independent contractors and Optionor shall have no liability arising from these parties' entries. Optionee shall restore the Property to the same condition that existed prior to such entry. Optionee hereby indemnifies and holds Optionor harmless from any and all loss, claim, actions, demand and liability, including reasonable attorneys' fees that may arise against Optionor or the Property by virtue of Optionee's or its employees and agents, actions in connection with this Agreement.

12. **Transfer Documents.** Optionor shall convey title to the Real Estate by a warranty deed acceptable to the Title Company as good and sufficient to convey marketable and insurable title to the Real Estate in the title condition provided for in this Agreement, plus the divisions to which Optionor may be entitled under Section 108 of the Land Division Act, 1967 P.A. 208; Optionor shall execute and deliver any other Closing or transfer documents that Optionee and the Title Company may reasonably require, including but not limited to an Owner's Affidavit.

13. **Closing.** Closing of this transaction shall occur by the payment of the full purchase price of Three Hundred Fifty Thousand and No/100 dollars (\$350,000.00). Closing shall be consummated within thirty (30) days of the exercise of this Option, or upon mutual agreement between Optionor and Optionee. Optionee shall have possession at time of closing.

14. **Notices.** All notices, demand and other communications hereunder shall be in writing and shall be deemed to have been duly given when physically delivered or seven days after having been deposited in the United States Mail, addressed to the recipient, as follows:

If to Optionor:

Uptown Reinvestment Corporation  
503 S. Saginaw Street, Suite 1500  
Flint, MI 48502  
Phone:  
Email: [jmartin@mott.org](mailto:jmartin@mott.org)

If to Optionee:

PK Development Group LLC  
1784 Hamilton Road  
Okemos, MI 48864  
Phone: 517-347-9662  
Email: [cpotterpin@pkhousing.com](mailto:cpotterpin@pkhousing.com)

15. **Risk of Loss.** If the Real Estate is materially damaged or destroyed by a casualty or taken, in whole or part, by eminent domain between the Effective Date and the Closing Date, then Optionor and Optionee shall negotiate in good faith to adjust the Purchase Price to reflect the change in fair market value. If the parties cannot agree on an adjusted Purchase Price within twenty (20) days following the applicable event (the "Election Period"), then Optionee shall elect, by giving written notice to Optionor, either to: (A) terminate this Agreement, in which case the Optionor shall return the Earnest Money Deposit to Optionee and this Agreement shall thereupon be null and void and neither party shall have any rights or obligations hereunder; or (B) close the transaction contemplated by this Agreement, in which case Optionee shall be entitled to any insurance proceeds less proceeds already expended to repair the Property (with payment by Optionor of any insurance deductible) or condemnation award resulting from such damage, destruction, condemnation or taking and shall have the absolute right to handle the negotiations and/or suit regarding same. If Optionee fails to notify Optionor by the expiration of the Election Period, Optionee shall be deemed to have elected option (B).



16. **Termination; Defaults and Remedies.**

A. **Optionor's Default.** If Optionor breaches or defaults in the performance of its obligations hereunder, which default is not due to the fault of Optionee, Optionee may, at its option, to the exclusion of any other remedies, (a) specifically enforce the terms of this Agreement in a court of equity or (b) terminate this Agreement and receive a refund of its Deposit, and Additional Deposit, if applicable, in which event neither party shall have any other or further liability hereunder.

B. **Optionee's Default.** Except as otherwise expressly provided herein, in the event Optionee breaches or defaults in the performance of its obligations hereunder, then provided Optionor is not also in default, Optionor shall, as its sole and exclusive remedy on account of Optionee's default, receive the Earnest Money Deposit as liquidated damages and neither party shall have any further liability or obligation to the other. Optionee acknowledges and agrees that actual damages in such event of default are uncertain in amount and difficult to ascertain and that the foregoing amount of liquidated

17. **Utilities and Survey.** Optionee assumes responsibility for the extension of utilities, roadways, surveys, permits, engineering as well as other fees pertaining to the easement of the property. Optionee agrees to extend the utility, water and sewer connection rights with the Property at no additional cost to the Optionor. Further, all property bordering the road, upon installation, will be final graded and seeded or appropriately landscaped.

18. **Miscellaneous.**

A. **Entire Agreement.** This Agreement constitutes the entire contract between the parties hereto, and may not be modified except by instrument in writing signed by the parties hereto.

B. **Governing Law.** This Agreement shall be governed by and construed in accordance with the laws of the State of Michigan.

C. **Time of Essence.** Time is of the essence in the performance by each party hereto of its obligations under this Agreement.

D. **Further Documents and Actions.** The parties hereto agree that at any time or from time to time after the execution of this Agreement and the Closing, they shall, upon the request of the other, execute and deliver such further documents and do such further actions and things as may be reasonably requested in order to fully effect the purposes of this Agreement.

E. **Assignment.** Optionee shall have the right to assign this Agreement and its rights hereunder at anytime prior to Closing without the consent of Optionor to any entity. In the event of such a transfer, the transferee shall assume the rights of the Optionee and the Optionee shall remain liable hereunder.

F. **Construction.** This Agreement shall not be construed more strictly against any one party than against any other party, merely by virtue of the fact that it may have been prepared by counsel for one of the parties, it being recognized that all of the parties

hereto and their respective counsel have contributed substantially and materially to the preparation of this Agreement.

G. **Counterparts**. This Agreement may be executed in any number of identical counterparts, any one of which may contain the signatures of less than all of the parties hereto, but all of which taken together shall constitute but one and the same agreement.

H. **Amendment**. This Agreement cannot be amended or modified except by a writing signed by all of the parties to be affected thereby.

I. **No Waiver of Rights**. Except as otherwise expressly provided herein, no failure or delay on the part of any party hereto in the exercise of any power or right hereunder shall operate as a waiver of such power or right with respect to any other term, provision or condition hereof and all rights and remedies hereunder are cumulative and shall not be deemed exclusive of any other rights or remedies provided by law.

J. **Severability**. Whenever possible, each provision of this Agreement and all related documents shall be interpreted in such a manner as to be valid under applicable law, but if any such provision is invalid or prohibited under said applicable law, such provision shall be ineffective to the extent of such invalidity or prohibition without invalidating the remainder of such provision or the remaining provision of the affected document.

Signature page to follow.

IN WITNESS WHEREOF, the parties hereto have executed this Option Agreement the day and year first written above.

WITNESS:

\_\_\_\_\_

OPTIONOR:

Uptown Reinvestment Corporation, a Michigan nonprofit corporation

By: \_\_\_\_\_

Address: 503 S. Saginaw Street, Suite 1500  
Flint, MI 48502

OPTIONEE:

PK Development Group, LLC, a Michigan limited liability company

\_\_\_\_\_

By: \_\_\_\_\_  
Chris Potterpin, Member

Address: 1784 Hamilton Rd  
Okemos, MI 48864

EXHIBIT A – Legal Description of the Property

- 847 N Stevenson Street, Flint, MI 48504

Legal Description: A. MCFARLAN'S REPLAT OF PARTS OF BLOCK 3, MCFARLAN & CO.'S COTTAGE GROVE ADDITION LOTS 13 AND 14; ALSO LOT 15 EXC BEG AT A PT ON NLY LINE OF SD LOT, 0.1 FT ELY FROM NWLY COR OF SD LOT; TH SELY ALG A 30 DEG 49 MIN CURVE TO THE RIGHT TO A PT ON SLY LINE OF SD LOT, 17.9 FT WLY FROM SELY COR OF SD LOT; TH ELY ALG SD SLY LINE 17.9 FT TO SD SELY COR; TH NLY ALG ELY LINE 28.3 FT TO NELY COR OF SD LOT; TH WLY ALG NLY LINE OF SD LOT, 108.4 FT TO POB; ALSO PART OF LOT 16 DESC AS: BEG AT A PT ON NLY LINE OF SD LOT, 17.9 FT WLY FROM NELY COR OF SD LOT; TH WLY ALG SD NLY LINE, 81.80 FT; TH SLY = WITH ELY LINE OF SD LOT, 0.66 FT; TH ELY 81.81 FT TO POB, BLK A

- 841 N Stevenson Street, Flint, MI 48504

Legal Description: LOTS 16 AND 17, BLK A OF A. MCFARLAN'S REPLAT OF PARTS OF BLOCK 3, MCFARLAN & CO.'S COTTAGE GROVE ADDITION EXC BEG AT THE SE'LY COR OF SD LOT 17; TH N'LY TO THE LT ALONG A 30 DEG 49 MIN CURVE TO A PT ON N LINE OF SD LOT 16, 17.9 FT W OF W LINE OF STEVENSON ST; TH E'LY 17.9 FT ALONG SD N LINE TO W LINE OF STEVENSON ST; TH S'LY TO POB; ALSO EXC BEG ON THE N LINE OF SD LOT 16, 17.9 FT W OF THE NE COR OF SD LOT; TH W ALONG SD N LINE 81.8 FT; TH S 30 DEG 0 MIN E 0.66 FT; TH E'LY 81.81 FT TO POB; ALSO LOT 17, BLK 3 EXC S'LY 26 FT OF MCFARLAN & CO.'S COTTAGE GROVE ADDITION.



## OPTION AGREEMENT

This Option Agreement, entered into this \_\_\_\_ day of January, 2021, between **DR. AHMED ARIF**, of 1201 Flushing Road, Flint, MI 48504 (hereinafter "Optionor"), and **PK DEVELOPMENT GROUP LLC** (or its assignee), a Michigan limited liability company, of 1784 Hamilton Road, Okemos, MI 48864 and **METRO COMMUNITY DEVELOPMENT**, a Michigan nonprofit corporation, of 503 S. Saginaw Street, Suite 804, Flint, MI 48502 (hereinafter collectively the "Optionee"), is entered for the purpose of giving the Optionee exclusive rights to purchase the property described on Exhibit A ("Property"), pursuant to the Flushing Place Development Plan demonstrated by Exhibit B ("Development Plan").

1. **Term of Option.** This Option for the Property is effective from the date set forth above until the 1<sup>st</sup> day of November, 2022.

2. **Earnest Money Deposit.** Optionee shall deposit in escrow with Cinnaire title Services, LLC (the "Title Company") the sum of Five Thousand and No/100 (\$5,000.00) Dollars cash, deposited within five (5) Business Days (as defined below) of the Effective Date (the "Initial Earnest Money Deposit"). The Earnest Money Deposit shall be held in a non-interest bearing account. The Earnest Money Deposit shall be credited to the Purchase Price at closing and shall be non-refundable upon expiration of the last to expire of the contingency periods except as otherwise specifically provided. For purposes hereof, the phrase "Business Days" shall mean the days of the week other than Saturday, Sunday, or a day on which banking institutions in Detroit, Michigan are obligated or authorized by law or executive action to be closed to the transaction of normal banking business.

3. **Escrow Agent.** The Escrow Agent shall be Cinnaire Title Services LLC of 1118 S. Washington Avenue, Lansing, MI 48910.

4. **Method of Exercising Option.** To exercise this Option, the Optionee shall notify the Optionor in writing that it is exercising the Option, and shall either personally deliver to or mail by certified mail, return receipt requested, such notice to the Optionor. To be effective, said notice must be sent by the Optionee on or before the expiration date of this Option.

5. **Terms of Agreement.** Optionor and Optionee hereby agree to the following terms upon which this Option shall be contingent:

A. Optionor shall receive a 15% net gain in parking spaces for the operation of his medical offices located at 1201 Flushing Road, Flint, MI 48504 during the first phase of construction under the Development Plan. The offices are currently served by 76 parking spaces and the final site shall therefore provide 88 parking spaces for use by the Optionor. Layout and design of the new parking area shall be subject to Optionor approval.

B. Optionor shall be granted and opportunity to review and approve the final site plan and massing for the first phase of the Development Plan.

E. Tax Credits, PILOT and Financing. The obligations of Optionee hereunder are subject to the following: (i) Optionee's successful obtainment of LIHTC credits upon terms and conditions satisfactory to Optionee, in Optionee's sole discretion; (ii) securing the required PILOT, which shall be diligently pursued; (iii) Receipt of a Commitment from a lender acceptable to Optionee for a construction and permanent loan; and (iv) Optionors compliance with the Letter Agreement dated November 24, 2020,

D. Optionee shall timely submit its initial application to the Michigan State Housing Development Authority ("MSHDA") for the February 2021 funding round and shall diligently pursue such application.

6. **Warranties and Representations.**

A. **Mutual Representations.** Each party represents and warrants to the other that: (1) it has full power and authority to enter into this Agreement and consummate the transactions contemplated by this Agreement; and (2) all necessary actions have been taken to authorize the signatories herein to execute and deliver this Agreement and the other documents and instruments contemplated by this Agreement.

B. **Inducement.** Each party makes the representations and warranties made by it in order to induce the other to enter into this Agreement.

C. **Optionor's Representations and Warranties.** Optionor represents and warrants that each of the following are true as of the Effective Date and will be true as of the date of Closing and makes these representations and warranties with the understanding that each of said representations and warranties is material, notwithstanding any investigations, inspections or examinations made by or on behalf of Optionee, and has been relied upon by Optionee in connection herewith and shall survive the Closing of any sale made pursuant to this Agreement and the delivery of the warranty deed and other closing documents. Optionor shall indemnify, defend and hold Optionee and its members, partners, officers, directors, employees and agents harmless from and against any and all claims, demands, liabilities, costs, expenses, penalties and damages, (including reasonable attorneys' fees) arising out of, resulting or related in any manner to a breach of any of these representations and warranties by Optionor.

1. **Litigation.** Optionor has no actual knowledge of any litigation, claim, governmental proceeding or investigation of any kind or nature pending or threatened, or any orders, judgments of any court relating to Optionor or the Property, or against Optionor's title to or right to possess the Property and Optionor has no knowledge or reason to believe that anyone other than Optionor has any interest or right whatsoever in the Property, except as disclosed in the title commitment.

2. **Other Claims.** Except as otherwise disclosed to Optionee on the Title Commitment, Optionor has received no notice and has no knowledge of any condemnation or regular or special assessment, or proceeding concerning same, affecting either the whole or any part of the Property, and no federal, state or local taxing authority has asserted any tax deficiency, lien or assessment against the Property or Optionor or any officers of Optionor.

3. Environmental Status. To the best of Optionor's knowledge, except with respect to the asbestos flooring, which has been encapsulated, Optionor has not received any notice from any applicable governmental entity or to the best of Optionor's knowledge any other person of the potential or actual existence of any hazardous material on, in, under or otherwise affecting the Property.

4. Construction Liens. Optionor represents and warrants that it has no knowledge of any claim for construction liens or of work done from which a construction lien could arise, and that all work done on the Property that could result in a construction lien has been paid or will be paid.

5. Ownership. To the best of Optionor's knowledge, it is the fee owner of the Property. Optionor has not granted, and shall not grant prior to closing, any option or rights of first refusal to third parties to acquire or purchase any interest in any of the Property that may impede Optionor's performance under this Agreement or remain outstanding after the Closing.

6. Bankruptcy. As of the Effective Date, there are no attachment, execution or assignment for the benefit of creditors or voluntary proceedings in bankruptcy or under other debtor relief law pending, contemplated by, or (to Optionor's knowledge) threatened against Optionor, or otherwise affecting all or any of the Property, other than any such action against an individual tenant. Optionor will, at closing, reaffirm this representation.

7. Condemnation. Optionor has not received any notice and has no actual knowledge of any pending or threatened condemnation or similar proceeding affecting any of the Property, or any pending public improvements in or adjoining any of the Property that could in any manner affect any of the Property.

8. Right to Possession. To the best of Optionor's knowledge, no person, firm, or corporation has a right to possession or is in possession of the Property or any portion thereof, as a lessee or tenant of Optionor or otherwise except as shown on the leases, rent roll and title report.

9. Optionor is not a foreign person as defined in Section 1445(f) (3) of the Internal Revenue Code and Regulations promulgated thereunder, which Optionor shall so certify at Closing.

Whenever a representation is qualified by the phrase "to Optionor's best knowledge" or by words of similar import, the accuracy of such representation shall be based solely on the actual knowledge without independent investigation or inquiry.

D. Optionee's Representations and Warranties. Optionee represents and warrants that each of the following are true as of the Effective Date and will be true as of the date of Closing and makes these representations and warranties with the understanding



that each of said representations and warranties is material, notwithstanding any investigations, inspections or examinations made by or on behalf of Optionor, and has been relied upon by Optionor in connection herewith and shall survive the Closing of any sale made pursuant to this Agreement and the delivery of the warranty deed and other closing documents. Optionee shall indemnify, defend and hold Optionor and its members, partners, officers, directors, employees and agents harmless from and against any and all claims, demands, liabilities, costs, expenses, penalties and damages, (including reasonable attorneys' fees) arising out of, resulting or related in any manner to a breach of any of these representations and warranties by Optionee.

1. Authority. Neither the execution and delivery of this Agreement nor the consummation of the transactions contemplated hereby will: (i) be in violation of Optionee's organizational documents; (ii) conflict with or result in a breach of any law, regulation, writ, injunction or decree of any court or governmental instrumentality applicable to Optionee; or (iii) constitute a breach of any agreement to which Optionee is a party or by which Optionee is bound.

2. OFAC. Each of Optionee and those persons and entities having any direct or indirect ownership interest in Optionee is: (i) not a "blocked" person listed in the Annex to Executive Order Nos. 12947, 13099 and 13224 and all modifications thereto or thereof (as used herein, the "Annex"); (ii) in full compliance with the requirements of the Patriot Act and all other requirements contained in the rules and regulations of the Office of Foreign Assets Control, Department of the Treasury ("OFAC"); (iii) operated under policies, procedures and practices, if any, that are in compliance with the Patriot Act; (iv) not in receipt of any notice from the Secretary of State or the Attorney General of the United States or any other department, agency or office of the United States claiming a violation or possible violation of the Patriot Act; (v) not listed as a "Specially Designated Terrorist" or as a "blocked" person on any lists maintained by the OFAC pursuant to the Patriot Act or any other list of terrorists or terrorist organizations maintained pursuant to any of the rules and regulations of the OFAC issued pursuant to the Patriot Act or on any other list of terrorists or terrorist organizations maintained pursuant to the Patriot Act; (vi) not a person who has been determined by competent authority to be subject to any of the prohibitions contained in the Patriot Act; and (vii) not owned or controlled by or now acting and or will in the future act for or on behalf of any person named in the Annex or any other list promulgated under the Patriot Act or any other person who has been determined to be subject to the prohibitions contained in the Patriot Act. All capitalized words and phrases and all defined terms used in the USA Patriot Act of 2001, 107 Public Law 56 (October 26, 2001) and in other statutes and all orders, rules and regulations of the United States government and its various executive departments, agencies and offices related to the subject matter of the Patriot Act, including Executive Order 13224 effective September 24, 2001 (collectively referred to as the "Patriot Act") are incorporated into this Section.

7. Contents of Real and Personal Property. Optionor shall retain ownership of all contents of the structures located on the Property and any personal property therein. Any contents

or personal property left on the property when Optionee takes possession shall be considered abandoned by Optionor. Optionor acknowledges that the structures will be demolished by Optionee shortly after closing and Optionor agrees to hold Optionee harmless for any loss of contents of the structures or personal property located on the Property when Optionee takes possession.

8. **Title.** Upon the execution of this Option Agreement, the Optionor shall have fifteen (15) days to provide a title commitment from the Escrow Agent in the amount of the Purchase Price insuring title in a form acceptable to Optionee. Optionor shall provide a fee simple title policy at closing and shall pay for the cost of said policy. If Optionor cannot provide marketable or insurable title, and/or the right to lease the Property in a form acceptable to Optionee, then Optionee shall be entitled to void this agreement.

8. **Assignment.** The Optionee has the sole right to assign this Option to any entity designated by Optionee without Optionor's consent.

9. **Taxes and Assessments.** All real estate taxes as of the Closing Date, shall be prorated as of date of Closing.

10. **Optionee's Right to Rezone.** Optionor agrees that the Optionee shall have the right during the Option period to apply for whatever municipal approvals are necessary to utilize the property for its intended use and that the Optionor shall support, and cooperate with any such approvals by Optionee.

11. **Site Inspection Rights:** Upon reasonable notice to Optionor, Optionee, and Optionee's agents, employees, contractors and consultants, shall have access to the Property to conduct such inspections, investigations, appraisals, tests and determinations of the Property as Optionee shall desire in order to determine, in Optionee's sole opinion, that the condition of the Property is acceptable and that the Property is suitable for Optionee's intended use. The cost of any and all such inspections, investigations, appraisals, tests and determinations shall be paid by the Optionee. Any report obtained shall be kept confidential and disclosed only to those necessary to effect this transaction. In the event Optionee discovers an environmental condition to which it objects, Optionee shall notify Optionor of such objection. Optionor shall have the right, but not the obligation, to correct such objection within thirty (30) days of notice of such objection which correction may be acceptable to Optionee in its sole discretion.

Optionee and its agents, employees and independent contractors shall have an irrevocable license and right to enter upon the Property during normal business hours after at least 48 hours prior notice to Optionor, for engineering, inspection and other purposes, including, but not limited to, feasibility studies, environmental inspections, the establishment of boundaries, the examination of any and all utilities and/or mechanical devices or equipment contained on the Property and the examination of the interior of and exterior to buildings and such other investigations as Optionee's lender may require. All such entries shall be at the risk of Optionee and its agents, employees and independent contractors and Optionor shall have no liability arising from these parties' entries. Optionee shall restore the Property to the same condition that existed prior to such entry. Optionee hereby indemnifies and holds Optionor harmless from any and all loss, claim, actions, demand and liability, including reasonable attorneys' fees that may arise against Optionor or the Property by virtue of Optionee's or its employees and agents, actions in connection with this Agreement.

12. **Transfer Documents**. Optionor shall convey title to the Real Estate by a warranty deed acceptable to the Title Company as good and sufficient to convey marketable and insurable title to the Real Estate in the title condition provided for in this Agreement, plus the divisions to which Optionor may be entitled under Section 108 of the Land Division Act, 1967 P.A. 208; Optionor shall execute and deliver any other Closing or transfer documents that Optionee and the Title Company may reasonably require, including but not limited to an Owner's Affidavit.

13. **Closing**. Closing of this transaction shall occur by the payment of the full purchase price of Two Hundred Fifty Thousand and No/100 dollars (\$250,000.00). Closing shall be consummated within thirty (30) days of the exercise of this Option, or upon mutual agreement between Optionor and Optionee. Optionee shall have possession at time of closing.

14. **Closing Costs**.

A. Optionor shall be responsible for the costs of the Owners Policy title insurance; transfer tax and fifty (50%) of the closing fee charged by Escrow Agent;

B. Optionee shall be responsible for recording fees and fifty (50%) percent of the Closing Fee charged by the Escrow Agent;

14. **Notices**. All notices, demand and other communications hereunder shall be in writing and shall be deemed to have been duly given when physically delivered or seven days after having been deposited in the United States Mail, addressed to the recipient, as follows:

If to Optionor:

Dr. Ahmed Arif  
1201 Flushing Road  
Flint, MI 48504  
Phone:  
Email: [aarif70@hotmail.com](mailto:aarif70@hotmail.com)

If to Optionee:

PK Development Group LLC  
1784 Hamilton Road  
Okemos, MI 48864  
Phone: 517-347-9662  
Email: [cpotterpin@pkhousing.com](mailto:cpotterpin@pkhousing.com)

15. **Risk of Loss**. If the Real Estate is materially damaged or destroyed by a casualty or taken, in whole or part, by eminent domain between the Effective Date and the Closing Date, then Optionor and Optionee shall negotiate in good faith to adjust the Purchase Price to reflect the change in fair market value. If the parties cannot agree on an adjusted Purchase Price within twenty (20) days following the applicable event (the "Election Period"), then Optionee shall elect,

by giving written notice to Optionor, either to: (A) terminate this Agreement, in which case the Optionor shall return the Earnest Money Deposit to Optionee and this Agreement shall thereupon be null and void and neither party shall have any rights or obligations hereunder; or (B) close the transaction contemplated by this Agreement, in which case Optionee shall be entitled to any insurance proceeds less proceeds already expended to repair the Property (with payment by Optionor of any insurance deductible) or condemnation award resulting from such damage, destruction, condemnation or taking and shall have the absolute right to handle the negotiations and/or suit regarding same. If Optionee fails to notify Optionor by the expiration of the Election Period, Optionee shall be deemed to have elected option (B).

16. **Termination; Defaults and Remedies.**

A. **Optionor's Default.** If Optionor breaches or defaults in the performance of its obligations hereunder, which default is not due to the fault of Optionee, Optionee may, at its option, to the exclusion of any other remedies, (a) specifically enforce the terms of this Agreement in a court of equity or (b) terminate this Agreement and receive a refund of its Deposit, and Additional Deposit, if applicable, in which event neither party shall have any other or further liability hereunder.

B. **Optionee's Default.** Except as otherwise expressly provided herein, in the event Optionee breaches or defaults in the performance of its obligations hereunder, then provided Optionor is not also in default, Optionor shall, as its sole and exclusive remedy on account of Optionee's default, receive the Earnest Money Deposit as liquidated damages and neither party shall have any further liability or obligation to the other. Optionee acknowledges and agrees that actual damages in such event of default are uncertain in amount and difficult to ascertain and that the foregoing amount of liquidated

17. **Utilities and Survey.** Optionee assumes responsibility for the extension of utilities, roadways, surveys, permits, engineering as well as other fees pertaining to the easement of the property. Optionee agrees to extend the utility, water and sewer connection rights with the Property at no additional cost to the Optionor. Further, all property bordering the road, upon installation, will be final graded and seeded or appropriately landscaped.

18. **Miscellaneous.**

A. **Entire Agreement.** This Agreement constitutes the entire contract between the parties hereto, and may not be modified except by instrument in writing signed by the parties hereto.

B. **Governing Law.** This Agreement shall be governed by and construed in accordance with the laws of the State of Michigan.

C. **Time of Essence.** Time is of the essence in the performance by each party hereto of its obligations under this Agreement.

D. **Further Documents and Actions.** The parties hereto agree that at any time or from time to time after the execution of this Agreement and the Closing, they shall, upon the request of the other, execute and deliver such further documents and do such further

actions and things as may be reasonably requested in order to fully effect the purposes of this Agreement.

E. **Assignment**. Optionee shall have the right to assign this Agreement and its rights hereunder at anytime prior to Closing without the consent of Optionor to any entity. In the event of such a transfer, the transferee shall assume the rights of the Optionee and the Optionee shall remain liable hereunder.

F. **Construction**. This Agreement shall not be construed more strictly against any one party than against any other party, merely by virtue of the fact that it may have been prepared by counsel for one of the parties, it being recognized that all of the parties hereto and their respective counsel have contributed substantially and materially to the preparation of this Agreement.

G. **Counterparts**. This Agreement may be executed in any number of identical counterparts, any one of which may contain the signatures of less than all of the parties hereto, but all of which taken together shall constitute but one and the same agreement.

H. **Amendment**. This Agreement cannot be amended or modified except by a writing signed by all of the parties to be affected thereby.

I. **No Waiver of Rights**. Except as otherwise expressly provided herein, no failure or delay on the part of any party hereto in the exercise of any power or right hereunder shall operate as a waiver of such power or right with respect to any other term, provision or condition hereof and all rights and remedies hereunder are cumulative and shall not be deemed exclusive of any other rights or remedies provided by law.

J. **Severability**. Whenever possible, each provision of this Agreement and all related documents shall be interpreted in such a manner as to be valid under applicable law, but if any such provision is invalid or prohibited under said applicable law, such provision shall be ineffective to the extent of such invalidity or prohibition without invalidating the remainder of such provision or the remaining provision of the affected document.

Signature page to follow.

IN WITNESS WHEREOF, the parties hereto have executed this Option Agreement the day and year first written above.

WITNESS:

\_\_\_\_\_

OPTIONOR:

By: \_\_\_\_\_

Dr. Ahmed Arif

Address: 1201 Flushing Road  
Flint, MI 48504

OPTIONEE:

PK Development Group, LLC, a Michigan limited liability company

\_\_\_\_\_

By: \_\_\_\_\_

Chris Potterpin, Member

Address: 1784 Hamilton Rd  
Okemos, MI 48864

EXHIBIT A – Legal Description of the Property

820 Frost Street, Flint, MI 48504 –

MCFARLAN & CO'S COTTAGE GROVE ADDITION LOTS 27, 28, 29 AND 30, BLK 3  
PROPERTY EXEMPT FROM AD VALOREM TAXES AND ASSESSED ON THE SPECIAL  
ACT ROLL PURSUANT TO PA 261 OF 2003 EXPIRING 12/30/2021

823 Stevenson Street, Flint, MI 48504 –

MCFARLAN & CO.'S COTTAGE GROVE ADDITION LOT 15, BLK 3

829 Stevenson Street, Flint, MI 48504 –

MCFARLAN & CO.'S COTTAGE GROVE ADDITION SLY 48 FT OF LOT 16, BLK 3

833 Stevenson Street, Flint, MI 48504 –

MCFARLAN & CO.'S COTTAGE GROVE ADDITION NLY 18 FT of LOT 16; ALSO SLY 26  
FT OF LOT 17, BLK 3