

## **Section 00 9113 Addendum No. 01**

WPC Sludge Dewatering Improvements Rehabilitation Project  
Proposal No. 20000582  
City of Flint, Michigan 48502

To all prospective bidders and others concerned, YOU ARE HEREBY ADVISED THAT the Contract Documents for the above referenced Project are revised in the following particulars:

### **Pre-Bid Meeting**

A mandatory, virtual pre-bid meeting was held on Thursday, June 11, 2020, at 9:00 AM. The sign-in sheet(s) and meeting minutes from the meeting are attached.

### **Section**

### **Description of Change**

00 1116

The Invitation to Bid shall be revised such that submittals shall be made to the City of Flint is as follows:

Due to Covid-19, the City of Flint is requiring the following for bid submittals:

One (1) electronic copy emailed to [purchasingbids@cityofflint.com](mailto:purchasingbids@cityofflint.com)  
One (1) unbound copy and one (1) thumb drive dropped off to the City of Flint.

Please note that electronic copies will need to be submitted to the City by the due date and time listed above. The City has set up a separate email set up for electronic bids and emails submitted to this email address will not be opened until the bid due date and time.

As City hall is still closed they MUST follow the following procedure in order to drop off bid submittals:

1. Have only one person drop off the bid at City hall.
2. Call Joyce McClane at 810-397-9649 and coordinate with her a time for bid drop off and you will receive instructions on where to meet at City hall. If Joyce does not answer, please leave a voicemail and wait for her to return your call.
3. Must practice social distancing guidelines.
4. Must wear a mask.

40 0552

Article 2.01.A.7 shall be revised to read as follows:

7. Valves shall be DeZurik, Val-Matic, Pratt, Crispin or Flomatic.

40 0552

The last sentence of Article 2.02.A.1 shall be revised to read as follows:

"...Valves shall be complete with outside lever and spring suitable for vertical or horizontal service and shall be Apco, Val-Matic, Crispin, Pratt or Flomatic."

40 0552

The last sentence of Article 2.02.A.2 shall be revised to read as follows:

"...Valves shall be Apco, Val-Matic, Crispin, Pratt. or Flomatic."

<u>Section</u>	<u>Description of Change</u>
40 0552	Article 2.04.A.2 and Article 2.04.B.2 shall both be revised to read as follows:

2. Valves shall be DeZurik, Val-Matic, Crispin, Pratt or Flomatic.

<u>Sheet</u>	<u>Description of Change</u>
D-001	Replace Sheet D-001 of the Contract Drawings in its entirety; a revised Sheet D-001 accompanies this Addendum. Changes to the drawing have been identified on the drawing itself and include but are not limited to (1) inclusion of a north arrow, (2) removal of extraneous section cuts, and (3) clarifications on pipe labeling.
D-002	Replace Sheet D-002 of the Contract Drawings in its entirety; a revised Sheet D-002 accompanies this Addendum. Changes to the drawing have been identified on the drawing itself and include but are not limited to (1) clarification on wall penetrations and need for link seals through existing and proposed walls/floors, (2) removal of extraneous section cuts, (3) clarifications on pipe labeling, and (4) clarification of slab on grade in area of proposed centrifuge equipment.
D-003	Replace Sheet D-003 of the Contract Drawings in its entirety; a revised Sheet D-003 accompanies this Addendum. Changes to the drawing have been identified on the drawing itself and include but are not limited to (1) clarification on wall penetrations and need for link seals through existing and proposed walls/floors, (2) removal of extraneous section cuts, and (3) clarifications on pipe labeling.
D-004	Replace Sheet D-004 of the Contract Drawings in its entirety; a revised Sheet D-004 accompanies this Addendum. Changes to the drawing have been identified on the drawing itself and include but are not limited to (1) clarification on wall penetrations and need for link seals through existing and proposed walls/floors, (2) removal of extraneous section cuts, (3) clarifications on pipe labeling, and (4) clarification of slab on grade in area of proposed centrifuge equipment.
D-005	Replace Sheet D-005 of the Contract Drawings in its entirety; a revised Sheet D-005 accompanies this Addendum. Changes to the drawing have been identified on the drawing itself and include but are not limited to (1) clarification on wall penetrations and need for link seals through existing and proposed walls/floors, (2) removal of extraneous section cuts, (3) clarifications on pipe labeling, and (4) clarification of slab on grade in area of proposed centrifuge equipment.

This Addendum is hereby incorporated into the original Contract Documents for the bidding referred to above and is considered as binding as though originally appearing therein. RECEIPT OF THIS ADDENDUM MUST BE NOTED in the place provided on the Proposal page 00 4243-1 and dated **June 17, 2020**.



## Pre-Bid Meeting Minutes

### City of Flint WPC Sludge Dewatering Improvements SRF #5696-01

Virtual MS Teams Meeting - Thursday, June 11, 2020 at 9:00 AM

#### Items to Discuss:

1. Welcome & Housekeeping
  - a. Sign-In
    - i. For those joining this meeting by computer, please use the “Chat” icon that appears near the bottom of your screen and submit your name and contact information (i.e., company, company address, email and telephone number) so that the moderator may verify your attendance and record it on a sign-in sheet. 
    - ii. For those joining by phone, please wait until the end of the meeting and the moderator will collect your information.
  - b. Questions
    - i. For those joining this meeting by computer and you have questions, please use the “Chat” icon and submit your questions to the moderator.
    - ii. For those joining by phone, please wait until there is a break in the presenter’s speaking or a call for questions.
  - c. Minutes from this meeting will be distributed as part of an Addendum and will include questions posed by potential bidders during the meeting.
2. Introduction
  - a. Owner: City of Flint  
Jeanette Best, WPC Manager  
Joyce McClane, Purchasing Manager
  - b. Engineer: Wade Trim (WT)  
John Arvai, PE, Project Manager  
Tiffany Harrison, PE, Project Engineer  
Hubbell, Roth & Clark (HRC)  
Trevor Wagenmaker, PE, Project Engineer
3. Purchasing Department Requirements
  - a. Bidding documents, including Contract Drawings, the Contract Manual (including procurement documents and technical specifications), as well as all Addenda to date are posted to the City’s website:  
<https://www.cityofflint.com/finance/purchasing/bids-2/>
  - b. When looking for documents related to this project, please use “P20-582” in the Search window.
  - c. Currently there are no Addenda posted for this project.

- d. Bids are to be submitted via email to [purchasingbids@cityofflint.com](mailto:purchasingbids@cityofflint.com) no later than 1:00 PM on July 1, 2020 **AND** Contractor is to drop off hard copies to City hall. As City Hall is still closed they MUST follow the following procedure.
  - i. Have only one person drop off the bids at City hall.
  - ii. Call Joyce McClane at 810-397-9649 and coordinate with her a time for bid drop off and you will receive instructions on where to meet at City hall. *If you reach Ms. McClane's voicemail, please leave a message and wait for a return call.*
  - iii. Must practice social distancing guidelines.
  - iv. Must wear a mask.
- e. The revised submission procedure will be addressed in an Addendum.

#### 4. Project Summary

- a. Work shall include the partial demolition and renovation of an existing building at the Water Pollution Control Facility, including but not limited to partial demolition of an existing 1-story structure and the construction of a 1-story wall for the portion of the structure that is to remain; construction of a new exterior wall along with two (2) overhead doors; the partial demolition of a large bank of windows and the construction of an exterior wall to take their place; the construction of an interior wall to create a new and separate room for the proposed solids dewatering equipment and appurtenances; upgrades and/or modifications to the existing electrical system including demolition of existing panels, conduit, and wiring, as well as new panels, conduit and wiring; separation of the existing ventilation system and installation of a new ventilation system with BACnet network to interface with the WPCF's existing HVAC control system for the partitioned area; two (2) centrifuges including necessary piping, valves, pumps, motor starters, variable frequency drives, programmable logic controllers, instrumentation and SCADA controls; and a polymer feed system consisting of two (2) polymer skids, a 6,000-gallon HDPE storage tank, piping, valves, pumps, mixing system, filling station, instrumentation and SCADA controls; two (2) horizontal split-case pumps, including motor starters, variable frequency drives, programmable logic controllers, instrumentation and SCADA controls; connection to existing sludge piping and the construction of new sludge transfer lines to the proposed centrifuge equipment, including pipe, bends, fittings, and valves as well as instrumentation and SCADA controls.
- b. This project is funding through the State Revolving Fund (SRF) program.
- c. Time is of the essence with this project and it is the City's intention that once the Work has been started, it shall proceed expeditiously.

#### 5. Contracting Requirements

- a. Bidder's Qualifications (Section 00 2113, Article 1.04): Indicates information regarding bidder's qualifications to perform the work must be submitted within 48 hours after Owner request.
- b. Examination of Site (Section 00 2113, Article 1.06):
  - i. Arrangements to visit the Water Pollution Control Facility will be made after this pre-bid meeting via Tiffany Harrison (Wade Trim).
- c. Bid Security (Section 00 2113, Article 1.08): 5% of the Bidder's maximum price in the form of a Bid Bond or Cashier's Check made payable to "Treasurer, City of Flint"

- d. Substitute or “Or-Equal” Items (Section 00 2113, Article 1.10): In no case shall denial of substitute application give rise to any claim for additional cost.
- e. Receipt and Form of Bid (Section 00 2113, Article 1.11):
  - i. Quantities (where provided) in the Proposal are approximate only and will be used as a basis of comparison of Bids, and award of Contracts. Payment will be made on basis of actual quantities of Work performed in accordance with the Contract Documents.
  - ii. Unit Prices bid, shall include such amounts as the Bidder deems proper for overhead, profit, taxes, General Conditions and such other incidentals as noted in the Contract Documents.
  - iii. Bid shall contain an acknowledgment of receipt of all Addenda.
  - iv. Legal Status of Bidder Form contained in the Contract Documents must be submitted with each Proposal and must clearly state the legal position of a Bidder (see Section 00 4345)
- f. American Iron & Steel Requirements (Section 00 2213, Article 1.01): This project is funded with monies made available by the State Revolving Fund and/or Drinking Water Revolving Fund and as such law contains provisions commonly known as “American Iron and Steel (AID)” that requires iron and steel products to be produced in the US, including iron and steel provided by the Contractor.
- g. Certification Regarding Debarment, Suspension and Other Responsibility Matters (Section 00 4345) must be submitted with each Proposal and must clearly status of the Bidder.
- h. Disadvantages Business Enterprise (Section 00 4539.13): Contractors bidding on this project must follow, document, and maintain documentation of their Good Faith Efforts to ensure DBEs have the opportunity to participate in the project.
- i. Contract Time (Section 00 5200): Work will be substantially completed within **four hundred twenty (420) calendar days** of the issuance of the Notice to Proceed, and completed and ready for final payment in accordance with the General Conditions within **four hundred eighty (480) calendar days** of said Notice.
- j. Liquidated Damages (Section 00 5200): **One Thousand Five Hundred Dollars (\$1,500.00)** for each day that expires after Substantial Completion until the Work is Substantially Complete; liquidated damages charged shall be deducted from the Contractor's progress payment.
- k. Prevailing Federal Wage Rate (Section 00 6521): This project is funded by federal dollars and is subject to the prevailing federal wage rate determination. An updated wage determination, if available, will be provided as part of an Addendum closer to the bid opening.
- l. Insurance Requirements (Section 00 7300): Additional insureds and insurance limits.
- m. Contract Closeout (Section 01 7700): Cleaning, project record documents, O&M data, spare parts and special tools, start-up, substantial completion, warranties, final payment and acceptance.

6. Important Project Elements

- a. This project will be constructed within an existing building located at the Water Pollution Control Facility and the information provided in the drawings is the best available, based on historical drawings and information provided by WPCF staff.
- b. Submittal Procedures (Section 01 3300): Schedules, shop drawings, product data, O&M data, audio-video route survey, photographs. Electronic submittals are acceptable and encouraged.
- c. Quality Control (Section 01 4500): Certification of materials. Field Testing by Contractor (concrete, compaction, etc).
- d. Temporary Facilities and Control (Section 01 5000): Site access and parking; public road maintenance, emergency access, public access to roadways, maintaining traffic, temporary utilities (power, sanitary, water, etc.).
  - i. Contractor will be required to provide a Field Trailer, which may be situated adjacent to the existing building where the Work is to take place.

7. Permits – By Contractor

- a. Building Permit is to be obtained by the Contractor from Flint Township

8. Project Timeline

- a. Bid Advertisement: Monday, June 1, 2020
- b. Virtual Mandatory Pre-bid Meeting: Thursday, June 11, 2020 at 9:00 AM EST
- c. In-Person Site Tour: By Appointment
- d. Final Date for Questions: Thursday, June 25, 2020 by 5:00 PM EST
- e. Final Addendum: Friday, June 26, 2020 by 5:00 PM EST
- f. Bid Due Date: Wednesday, July 1, 2020 by 1:00 PM EST
- g. Bid Review: Tuesday, July 2, 2020
- h. Introduce to Finance Committee: Tuesday, July 8, 2020
- i. Anticipated City Council Approval: Monday July 27, 2020
- j. Anticipated Contract Execution: Wednesday, August 26, 2020
- k. \*Anticipated Notice to Proceed: Wednesday, September 2, 2020
- l. \*\*Substantial Completion Wednesday, October 27, 2021
- m. \*\*Final Completion Monday, December 27, 2021

*\*This project is funded through SRF and the bond closing date is scheduled for September 1, 2020.*

*\*\*Assumes NTP issued 9/2/2020 and 420 calendar days until SC and 480 calendar days to FC.*

9. Addenda

- a. Addendum No. 1 will be issued and will include pre-bid meeting minutes and sign-in sheet, revised bid submission requirements, revised specifications (if applicable), reissued Contract Drawings (if applicable), revised wage determination (if applicable) and any other contract documents necessary for clarification.

## **Site Visit**

1. Safety Requirements – Please bring and wear a mask in addition other standard PPE ,  
*including steel-toed boots.*
2. Schedule

## **Questions by Audience**

*Q: Any need for temporary dewatering while this is under construction.*

*A: Per John Arvai, dewatering is not needed during construction; this project will be providing redundancy at the plant and the existing sludge dewatering process will not be affected.*

## **Adjournment**

*Meeting adjourned at 9:30 AM*



## Sign-In Sheet

Project: Sludge Dewatering Improvements  
Purpose: Pre-Bid Meeting

Job No.: COF107201F  
Date/Time: 6/11/20 at 9:00 AM

Name/Title	Company	Address	E-Mail	Telephone
Tiffany Harrison, PE Engineer	Wade Trim, Inc.	555 S. Saginaw St, Suite 201 Flint, MI 48502	<a href="mailto:tharrison@wadetrim.com">tharrison@wadetrim.com</a>	810.553.6541
John Arvai, PE Engineer	Wade Trim, Inc.	25251 Northline Rd Taylor, MI 48180	<a href="mailto:jarvai@wadetrim.com">jarvai@wadetrim.com</a>	734.249.2157
Jeanette Best WPC Manager	City of Flint Water Pollution Control Facility	G4652 Beecher Rd Flint, MI 48532	<a href="mailto:jbest@cityofflint.com">jbest@cityofflint.com</a>	810.691.9811
John Florshinger SCADA & Maintenance Super.	City of Flint Water Pollution Control Facility	G4652 Beecher Rd Flint, MI 48532	<a href="mailto:jflorshinger@cityofflint.com">jflorshinger@cityofflint.com</a>	810.766.7210
Joyce McClane Purchasing Manager	City of Flint Purchasing Department	1101 S. Saginaw St Flint, MI 48502	<a href="mailto:jmcclane@cityofflint.com">jmcclane@cityofflint.com</a>	810.766.7340
Chuck Ellingson	Commercial Contracting	4260 N. Atlantic Blvd Auburn Hills, MI 48326	<a href="mailto:chuck.ellingson@cccnetwork.com">chuck.ellingson@cccnetwork.com</a>	248.209.0500
Henry Taylor	Newkirk Electric	2751 Lippincott Blvd Flint, MI 48507	<a href="mailto:hbraylor@newkirk-electric.com">hbraylor@newkirk-electric.com</a>	810.742.4400
Rod Bauer	RCL Construction Co.	777 W. Maynard Rd Sanford, MI 48657	<a href="mailto:Rod@rclconstruct.com">Rod@rclconstruct.com</a>	989.687.7319
Ryan Sly	Sorensen Gross Company	3407 Torrey Road Flint, Mi 48507	<a href="mailto:rsly3@sgcs.net">rsly3@sgcs.net</a>	810.767.4821
Sabrina Byers	LaSalle Construction	sbyers@lasalleinc.com	<a href="mailto:sbyers@lasalleinc.com">sbyers@lasalleinc.com</a>	734.394.0650
Tim Stewart	Merrell Brothers, Inc.	8811 W. 500 N Kokomo, IN, 46901	<a href="mailto:tim@merrellbros.com">tim@merrellbros.com</a>	800.663.8830
Lynn Natzic, PE	Reliance Building Co.	26200 Town Center Dr, Suite 195, Novi, MI 48375	<a href="mailto:Lynn@RelianceBC.com">Lynn@RelianceBC.com</a>	248.374.3210
Jessica George	J. F. Cavanaugh Company	20750 Sunnysdale St Farmington Hills, MI 48336	<a href="mailto:jessica@jfcav.com">jessica@jfcav.com</a>	248.476.9366



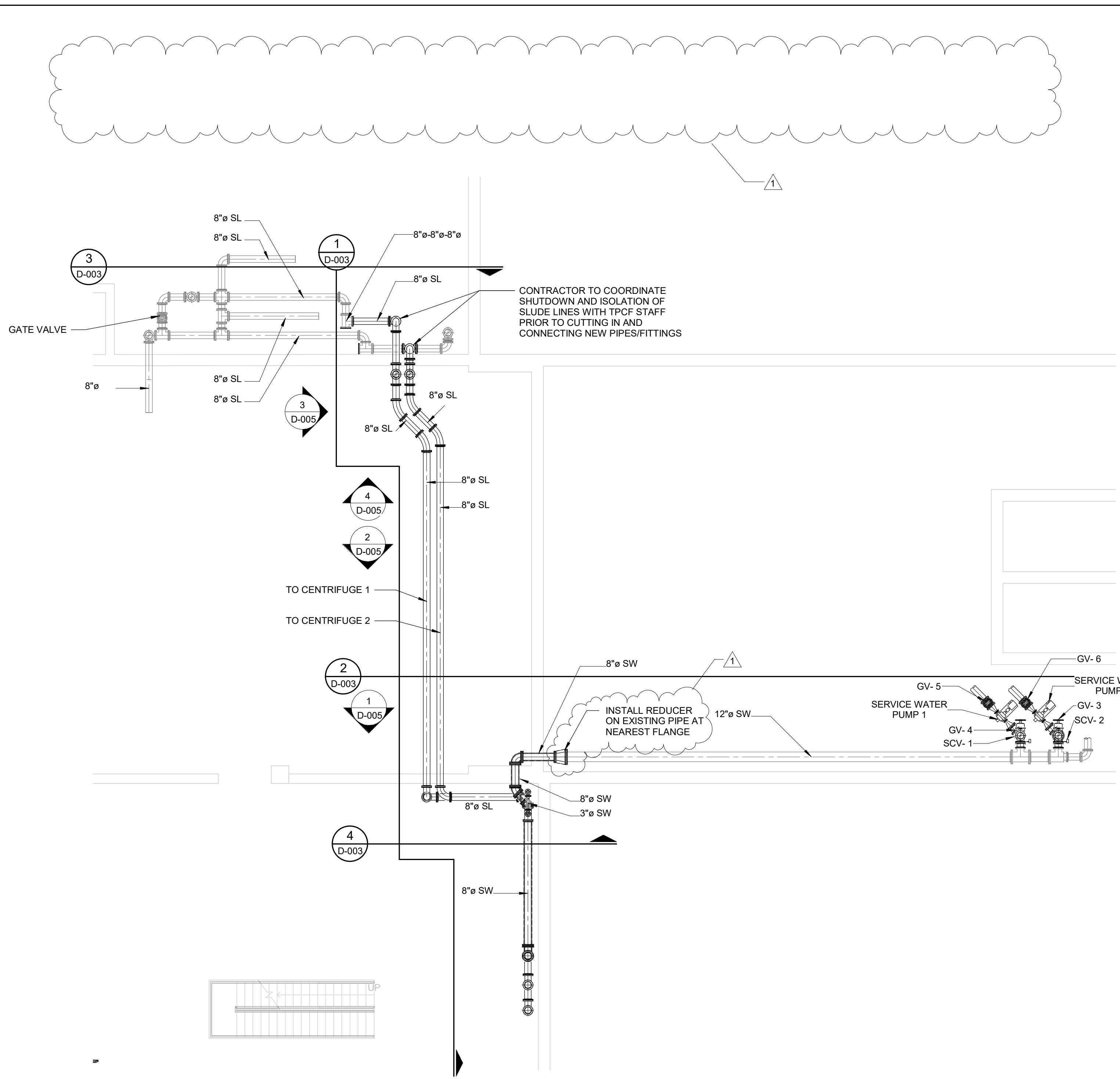

**001 LOWER LEVEL PROCESS**  
SCALE: 1/8" = 1'-0"

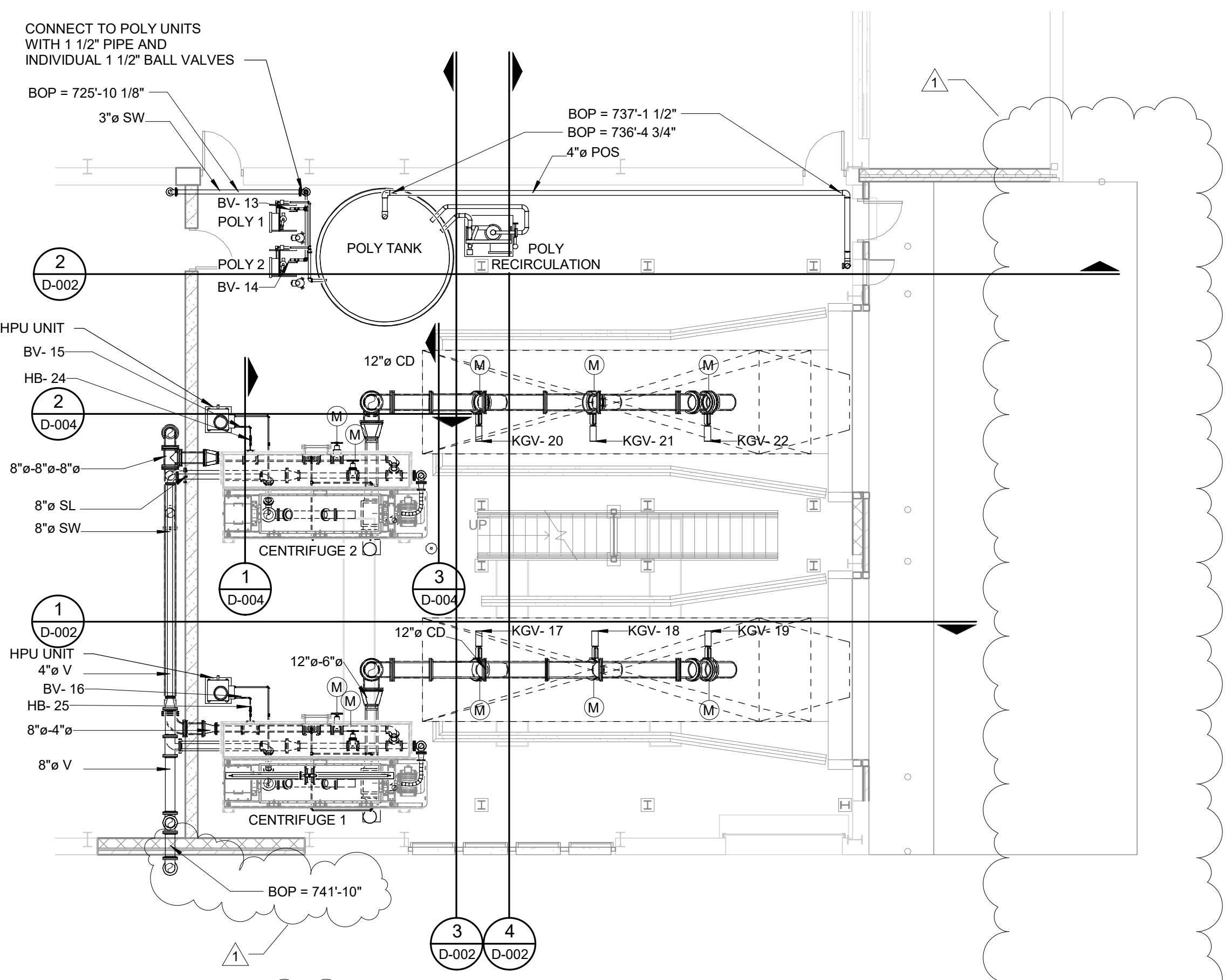

**01 GROUND FLOOR PROCESS**  
SCALE: 1/8" = 1'-0"

NOTES:  
ALL REDUCERS ON SLUDGE LINES, CAKE LINES, AND SERVICE WATER LINES SHALL BE ECCENTRIC (TOPS FLAT).  
ALL ELBOWS ON SLUDGE AND CAKE PIPING SHALL BE LONG RADIUS  
PROVIDE PIPE SLEEVES AND LINK SEAL ALL PIPE PENETRATIONS THROUGH NEW WALLS  
CORE AND LINK SEAL ALL PIPE PENETRATIONS THROUGH EXISTING WALLS

CONTRACTOR TO COORDINATE SHUTDOWN AND ISOLATION OF SLUDGE LINES WITH TPCF STAFF PRIOR TO CUTTING IN AND CONNECTING NEW PIPES/FITTINGS

INSTALL REDUCER ON EXISTING PIPE AT NEAREST FLANGE

CONNECT TO POLY UNITS WITH 1 1/2" PIPE AND INDIVIDUAL 1 1/2" BALL VALVES

PLOTTED 2020.06.12 3:31:04 PM

V:\0298348\COF\07201E\_WPC-Sludge-Dewatering-Improvements\_D-1.rvt

REV#	DATE	DESCRIPTION	TH	BY
1	06/15/2020	ADDENDUM 1		



**WADE TRIM**  
555 South Saginaw Street, Suite 201  
Flint, MI 48502  
610.235.2555/800.841.0342  
FAX: 810.235.4975  
www.wadetrिम.com

**HRC**  
HUBBELL, ROTH & CLARK, INC.  
CONSULTING ENGINEERS SINCE 1915  
505 WEST BERRY  
BLOOMFIELD HILLS, MICH. P.O. BOX 65  
48302 - 0824  
PHONE: (248) 654-6300  
FAX (248) 654-6312  
FAX (248) 338-2382  
WEB SITE: http://www.hrc-corp.com

CITY OF FLINT  
1101 SAGINAW STREET, FLINT, MICHIGAN 48502  
FLINT WASTE WATER TREATMENT PLANT  
SLUDGE DEWATERING IMPROVEMENTS  
PLAN VIEWS

ISSUED FOR:	DATE:	BY:
90% REVIEW	03/25/2020	TH
100% REVIEW	04/17/2020	TH
IFB	06/01/2020	TH

JOB NO.  
**COF107201F**

SHEET  
**D-001**

© Wade Trim Group, Inc.

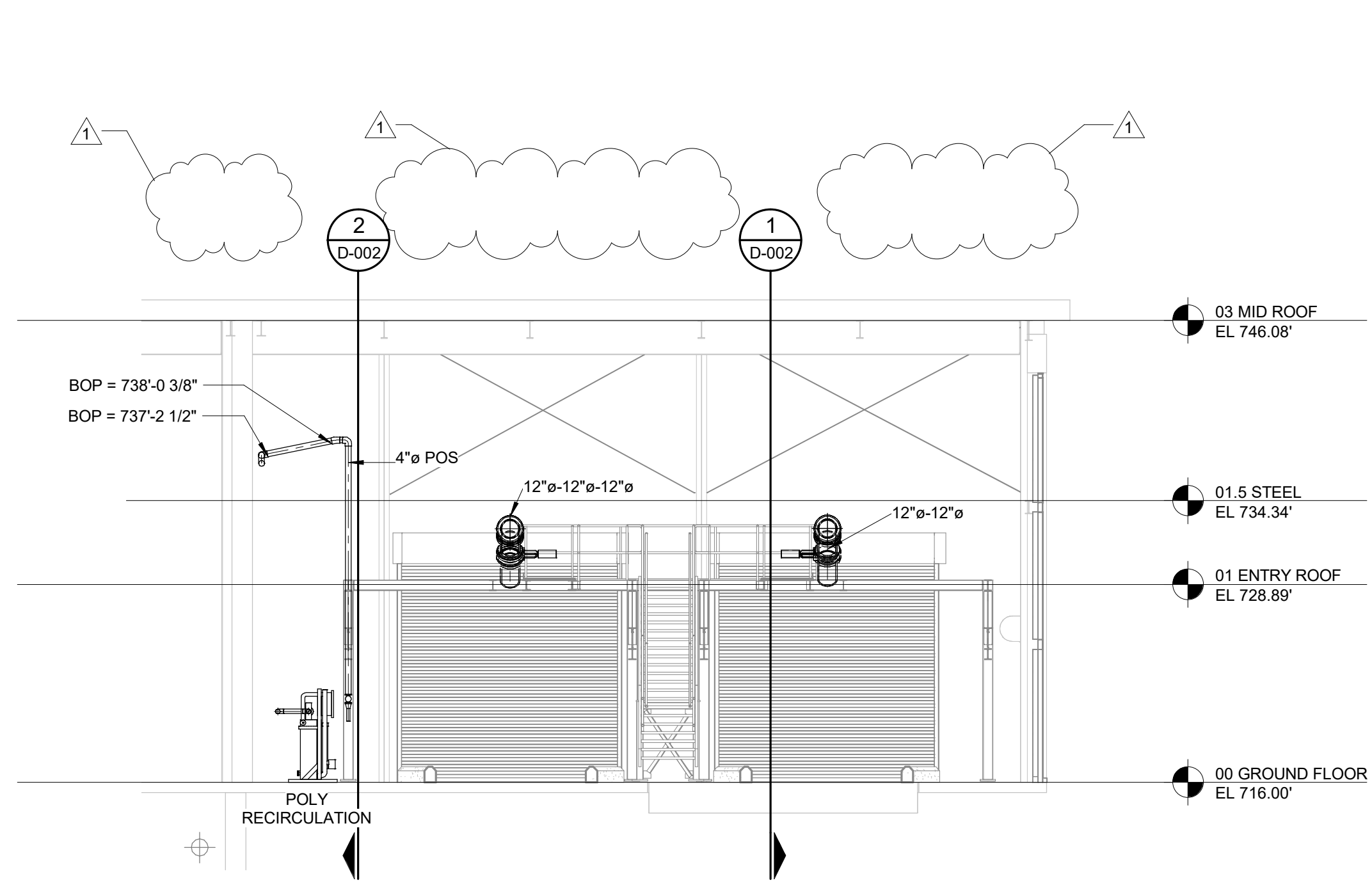

**4 TRUCK BAY SECTION 4**  
D-001 SCALE: 1/8" = 1'-0"

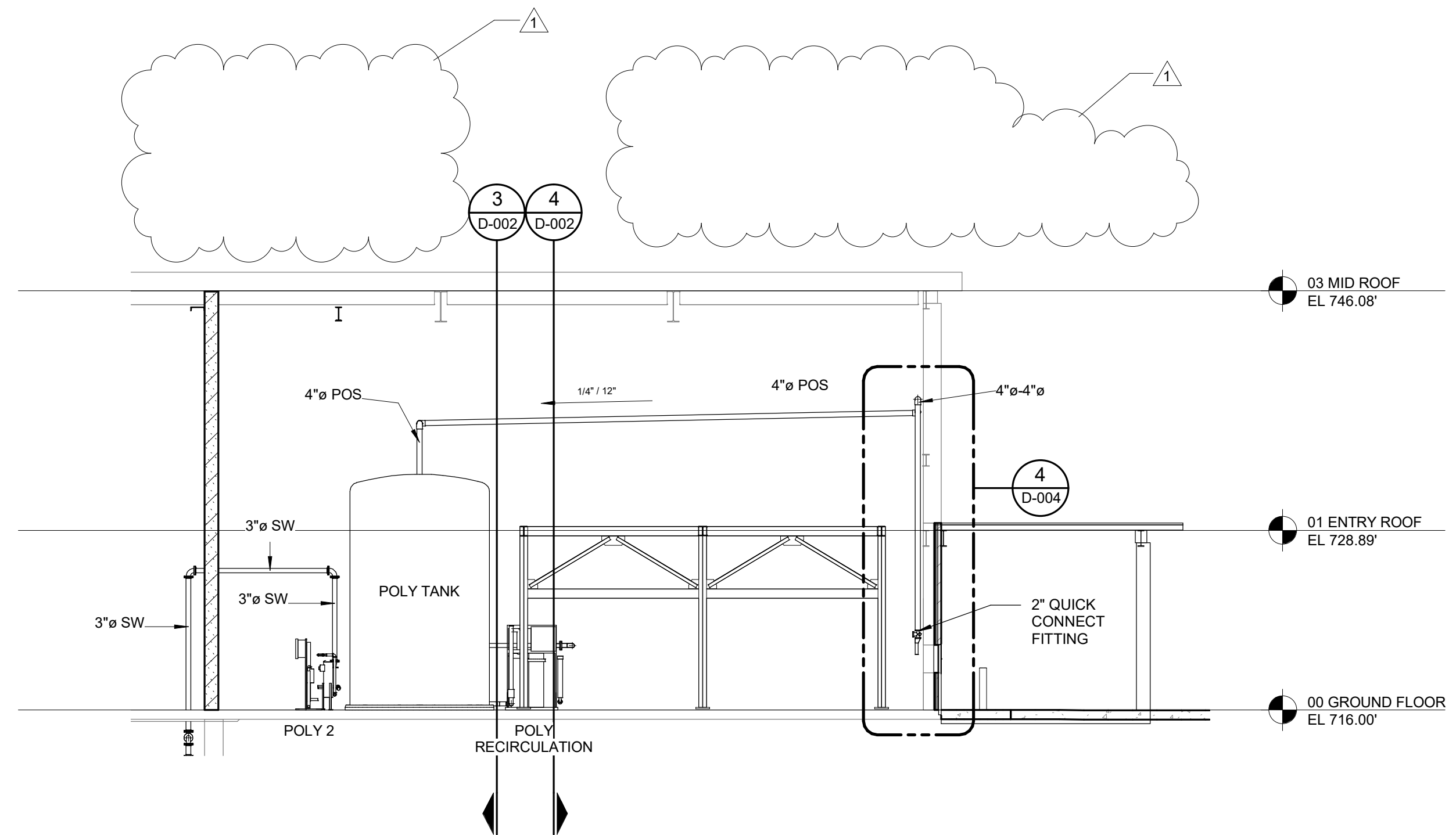

**2 TRUCK BAY SECTION 2**  
D-001 SCALE: 1/8" = 1'-0"

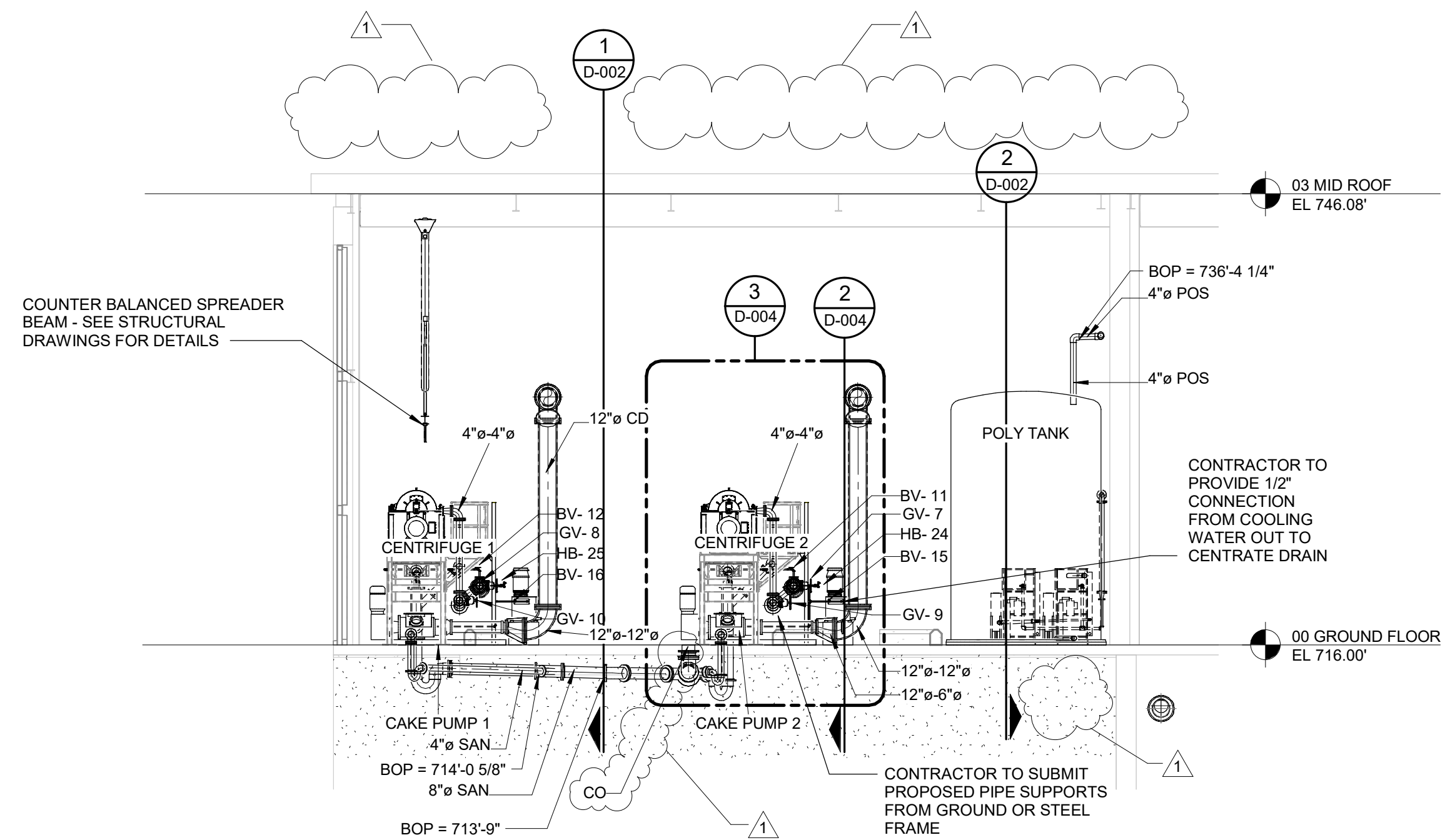

**3 TRUCK BAY SECTION 3**  
D-001 SCALE: 1/8" = 1'-0"

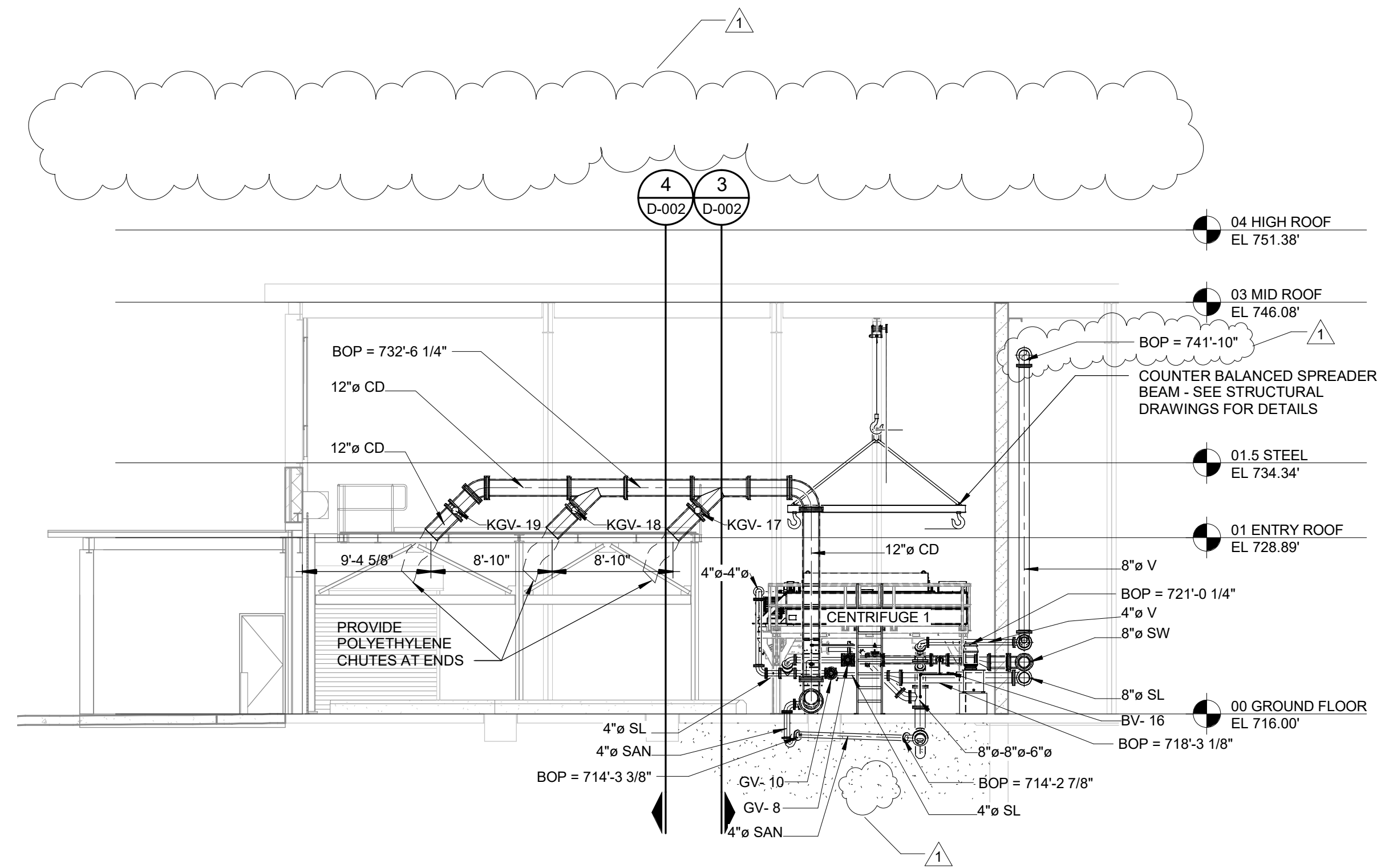

**1 TRUCK BAY SECTION 1**  
D-001 SCALE: 1/8" = 1'-0"

- NOTES:**
- ALL REDUCERS ON SLUDGE LINES, CAKE LINES, AND SERVICE WATER LINES SHALL BE ECCENTRIC (TOPS FLAT).
  - ALL ELBOWS ON SLUDGE AND CAKE PIPING SHALL BE LONG RADIUS
  - PROVIDE PIPE SLEEVES AND LINK SEAL ALL PIPE PENETRATIONS THROUGH NEW WALLS
  - CORE AND LINK SEAL ALL PIPE PENETRATIONS THROUGH EXISTING WALLS

PLOTTED 2020.08.12 3:31:16 PM

V:\0298248\COF\07201E\_WPC\Sludge-Dewatering-Improvements\_D-17.rvt

REV#	DATE	DESCRIPTION	TH	BY
1	08/15/2020	ADDENDUM 1		



**WADE TRIM**  
555 South Saginaw Street, Suite 201  
Flint, MI 48502  
610.235.2555/800.841.0342  
FAX: 810.235.4975  
www.wadetrिम.com

**HRC**  
**HUBBELL, ROTH & CLARK, INC.**  
CONSULTING ENGINEERS SINCE 1915  
505 WEST HENRY  
BLOOMFIELD HILLS, MICH. 48304-0824  
PHONE: (248) 654-6300  
FAX (Toll Free): (248) 654-6312  
FAX (On Site): (248) 338-2392  
WEB SITE: http://www.hrc-enr.com

CITY OF FLINT  
1101 SAGINAW STREET, FLINT, MICHIGAN 48502  
FLINT WASTE WATER TREATMENT PLANT  
SLUDGE DEWATERING IMPROVEMENTS  
GROUND FLOOR SECTION VIEWS

ISSUED FOR:	DATE:	BY:
90% REVIEW	03/25/2020	TH
100% REVIEW	04/17/2020	TH
IFB	06/01/2020	TH

JOB NO.  
**COF107201F**

SHEET  
**D-002**

© Wade Trim Group, Inc.



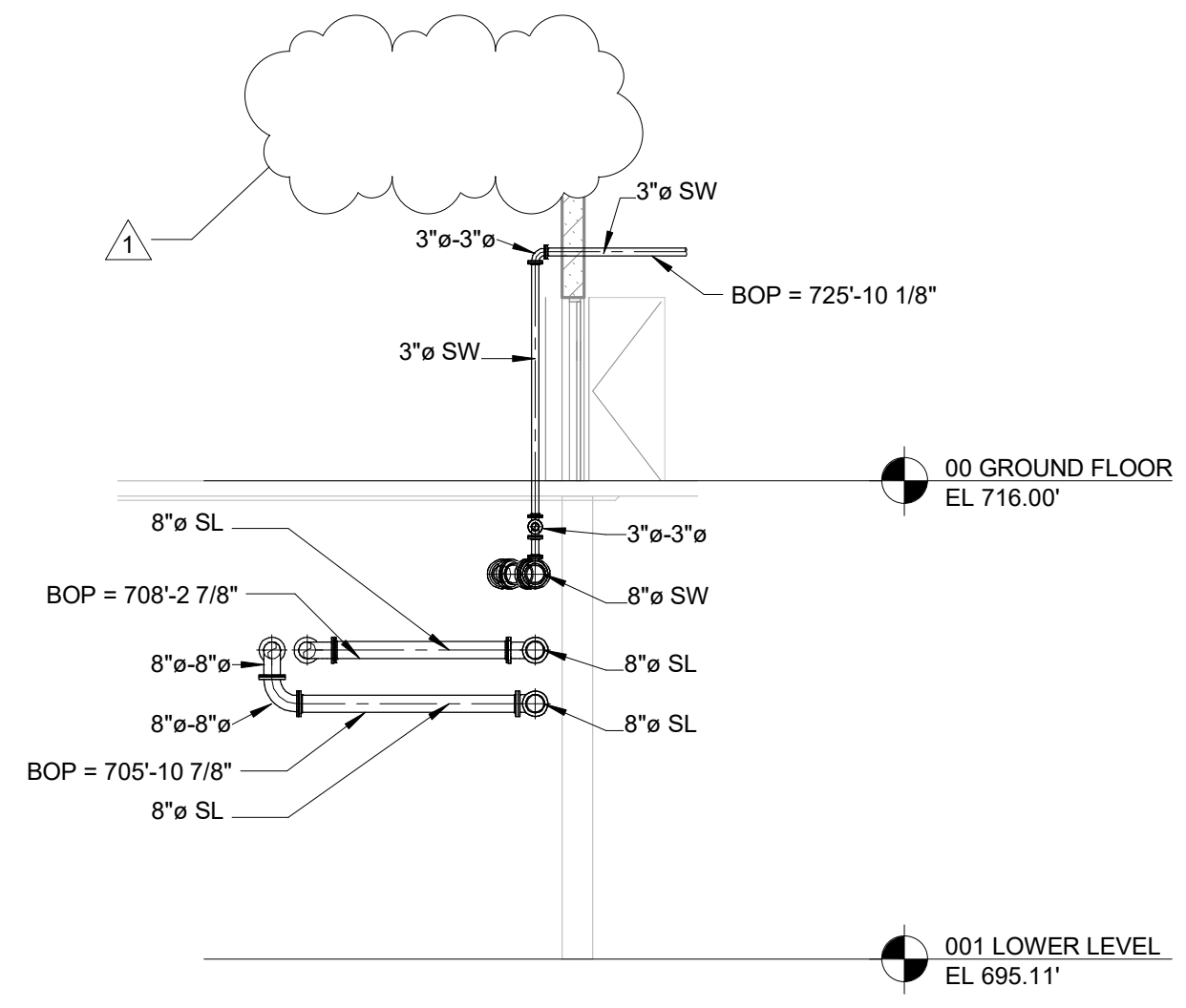

**4 WALL PENETRATION DETAIL**  
D-001 SCALE: 1/8" = 1'-0"

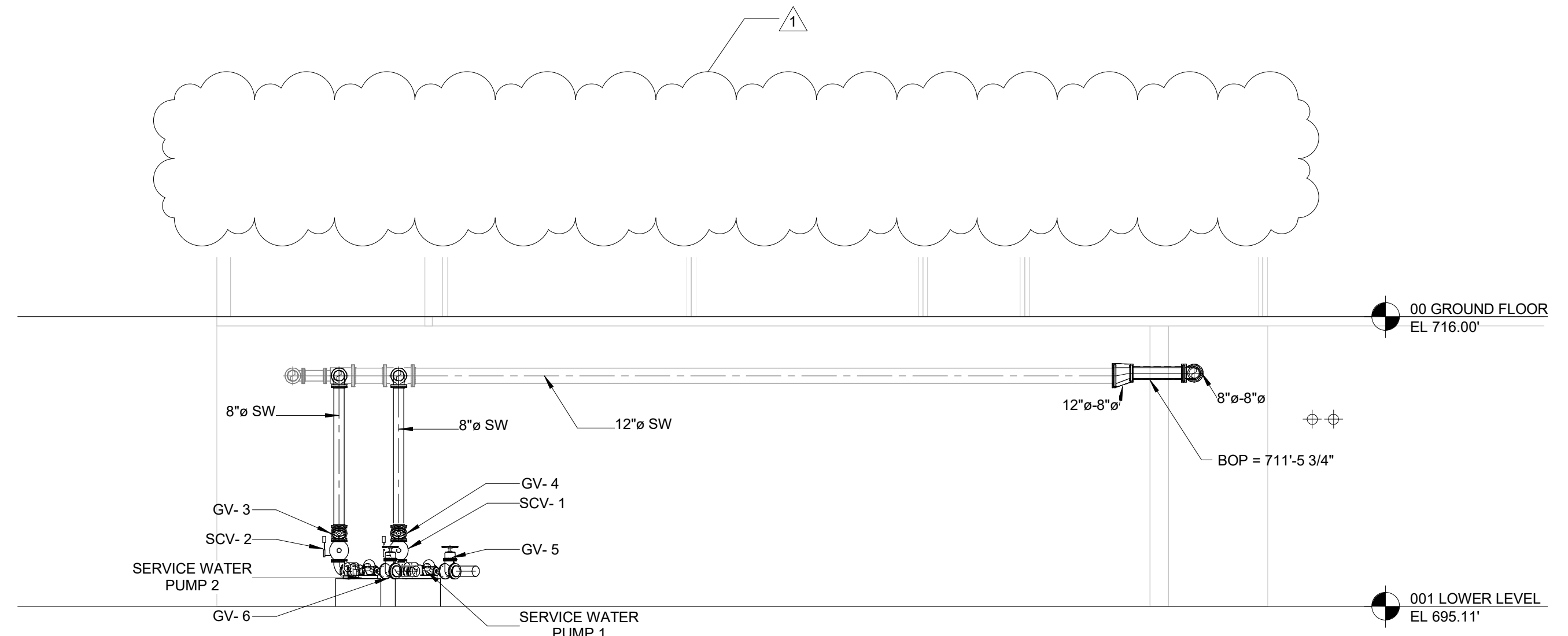

**2 NEW SERVICE WATER PUMP CONNECTION**  
D-001 SCALE: 1/8" = 1'-0"

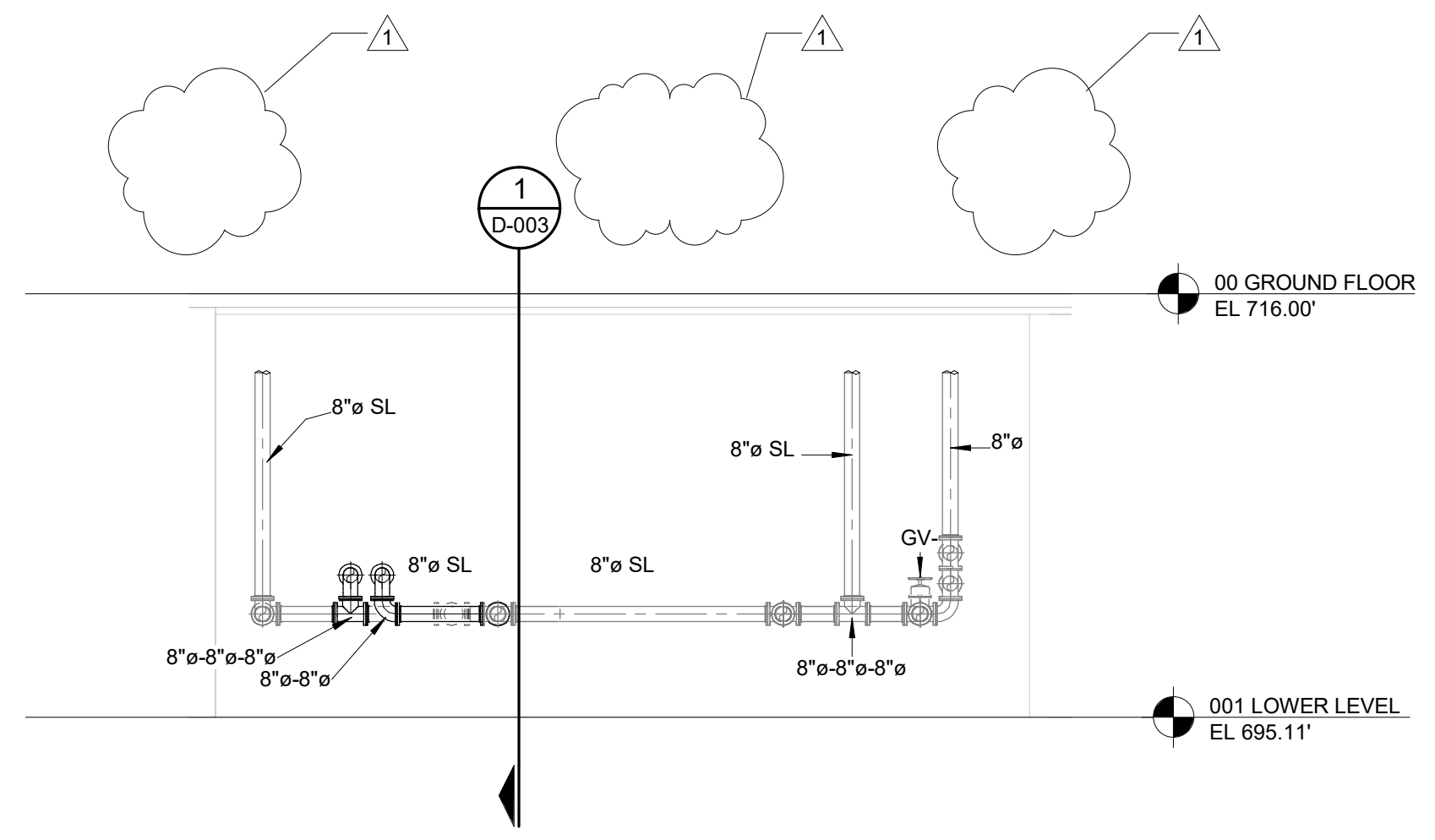

**3 EXISTING TIE IN LOCATION**  
D-001 SCALE: 1/8" = 1'-0"

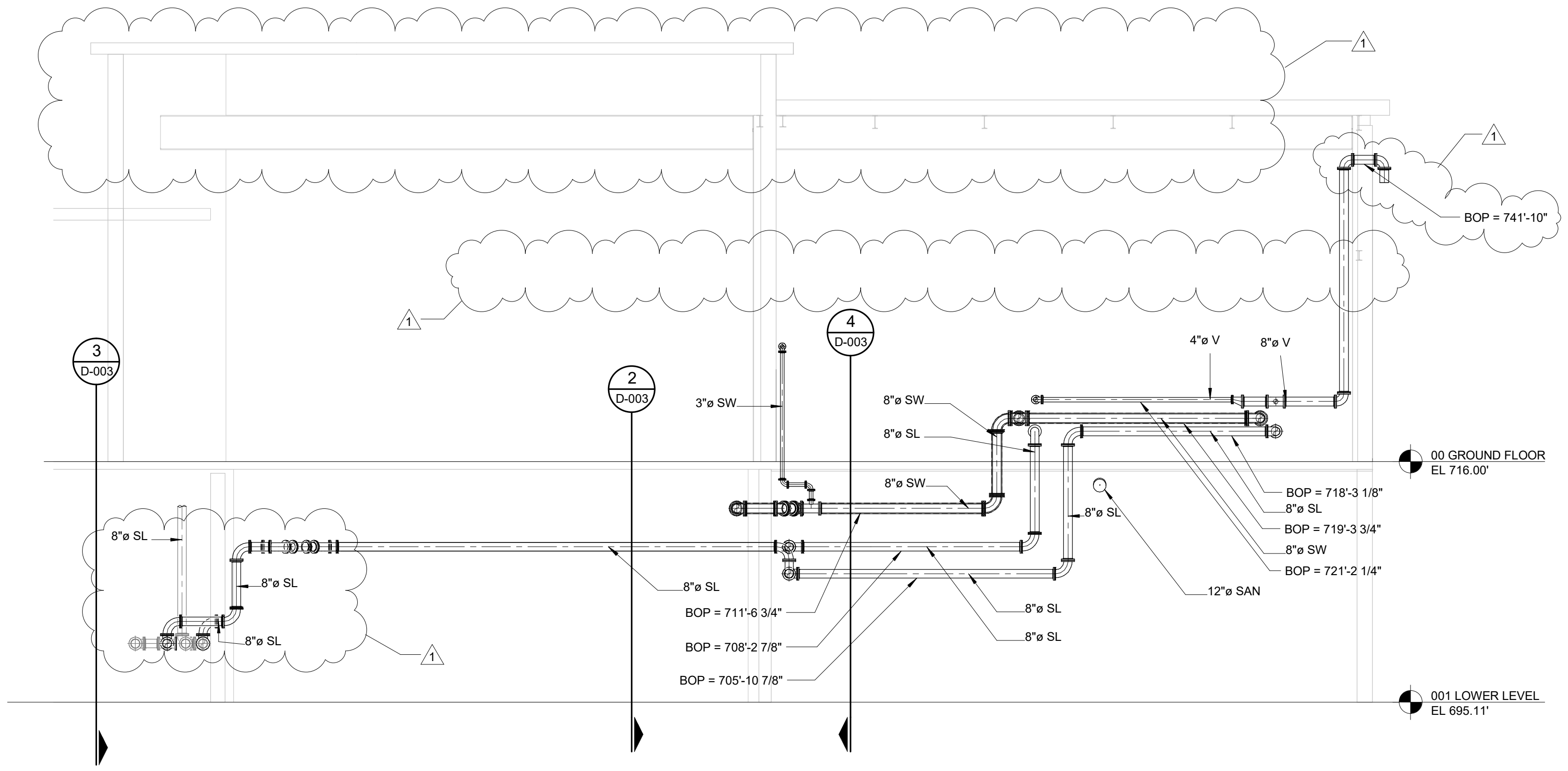

**1 NEW CONNECTION PIPING**  
D-001 SCALE: 1/8" = 1'-0"

NOTES:  
 ALL REDUCERS ON SLUDGE LINES, CAKE LINES, AND SERVICE WATER LINES SHALL BE ECCENTRIC (TOPS FLAT).  
 ALL ELBOWS ON SLUDGE AND CAKE PIPING SHALL BE LONG RADIUS.  
 PROVIDE PIPE SLEEVES AND LINK SEAL ALL PIPE PENETRATIONS THROUGH NEW WALLS.  
 CORE AND LINK SEAL ALL PIPE PENETRATIONS THROUGH EXISTING WALLS.

PLOTTED 2020.06.12 3:31:19 PM

V:\0298348\COF\107201E\_WPC-Sludge-Dewatering-Improvements\_D-1.rvt

REV#	DATE	DESCRIPTION	TH	BY
1	06/15/2020	ADDENDUM 1		



**WADE TRIM**  
 555 South Saginaw Street, Suite 201  
 Flint, MI 48502  
 810.235.2555/800.841.0342  
 FAX: 810.235.4975  
 www.wadetim.com

**HRC**  
 HUBBELL, ROTH & CLARK, INC.  
 CONSULTING ENGINEERS SINCE 1915  
 500 WEST BERRY  
 BLOOMFIELD HILLS, MICH. 48304-0824  
 PHONE: (248) 654-6300  
 FAX (Toll Free): (248) 654-6312  
 FAX (Local): (248) 338-2392  
 WEB SITE: http://www.hrc-corp.com

CITY OF FLINT  
 1101 SAGINAW STREET, FLINT, MICHIGAN 48502  
 FLINT WASTE WATER TREATMENT PLANT  
 SLUDGE DEWATERING IMPROVEMENTS  
 LOWER LEVEL SECTION VIEWS

ISSUED FOR:	DATE:	BY:
90% REVIEW	03/25/2020	TH
100% REVIEW	04/17/2020	TH
IFB	06/01/2020	TH

JOB NO.  
COF107201F

SHEET  
D-003

© Wade Trim Group, Inc.

PLOTTED 2020.06.12 3:31:28 PM

V:\0298348\COF\107201E\_WPC-Sludge-Dewatering-Improvements\_D-17.rvt

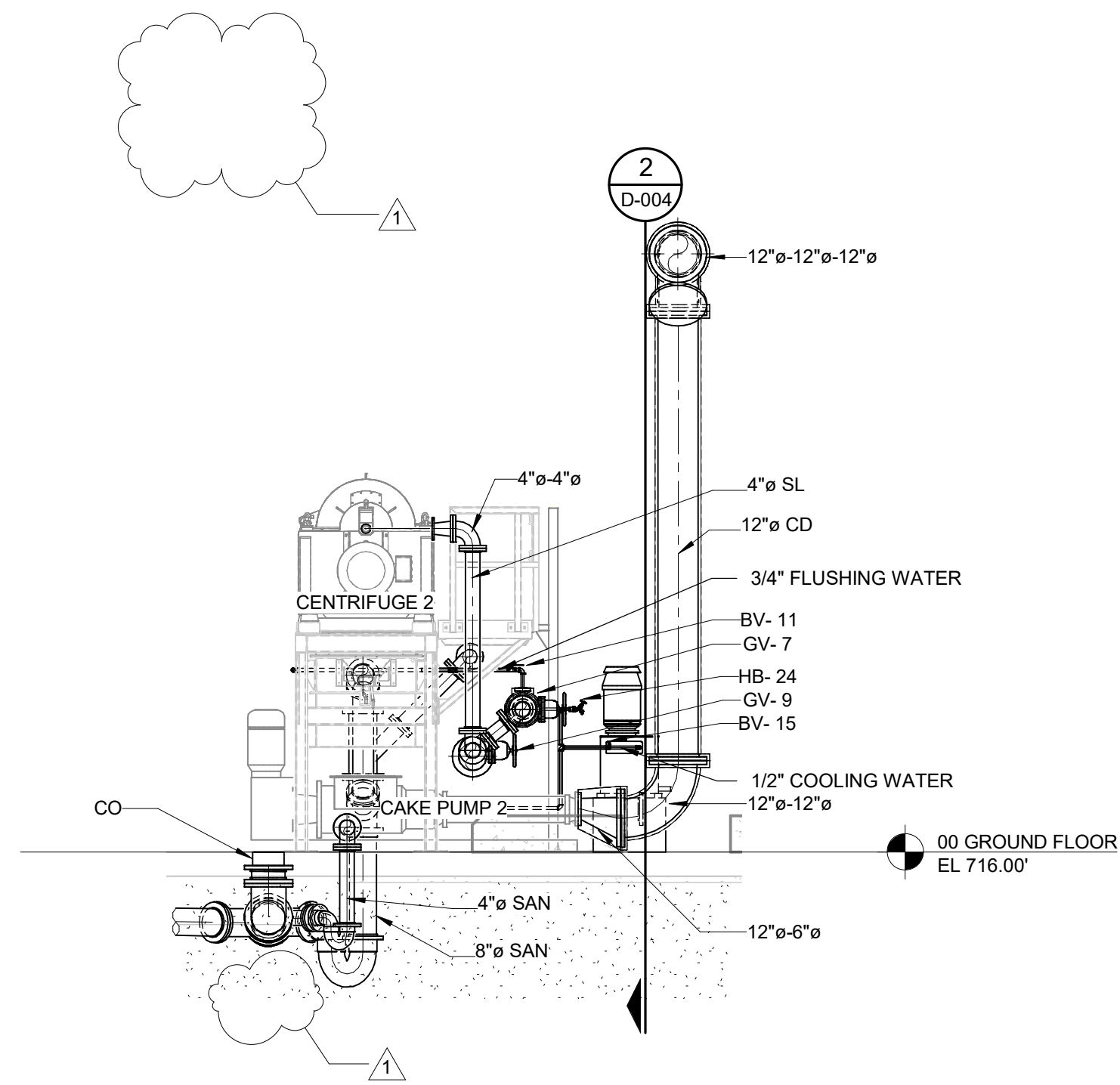

**3**  
D-001 **CENTRIFUGE PIPING DETAIL - LEFT VIEW**  
SCALE: 1/4" = 1'-0"

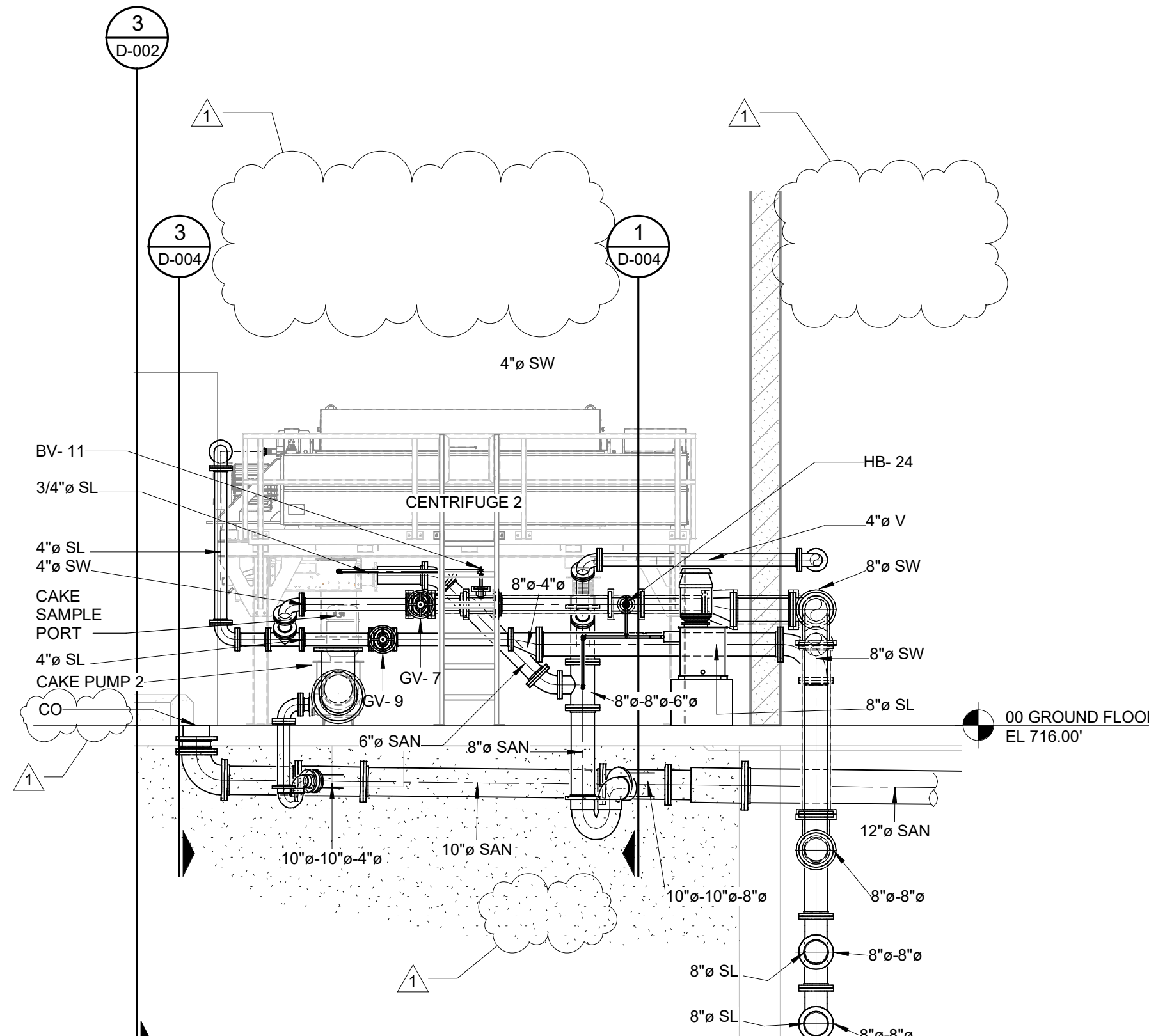

**2**  
D-001 **CENTRIFUGE PIPING DETAIL - FRONT VIEW**  
SCALE: 1/4" = 1'-0"

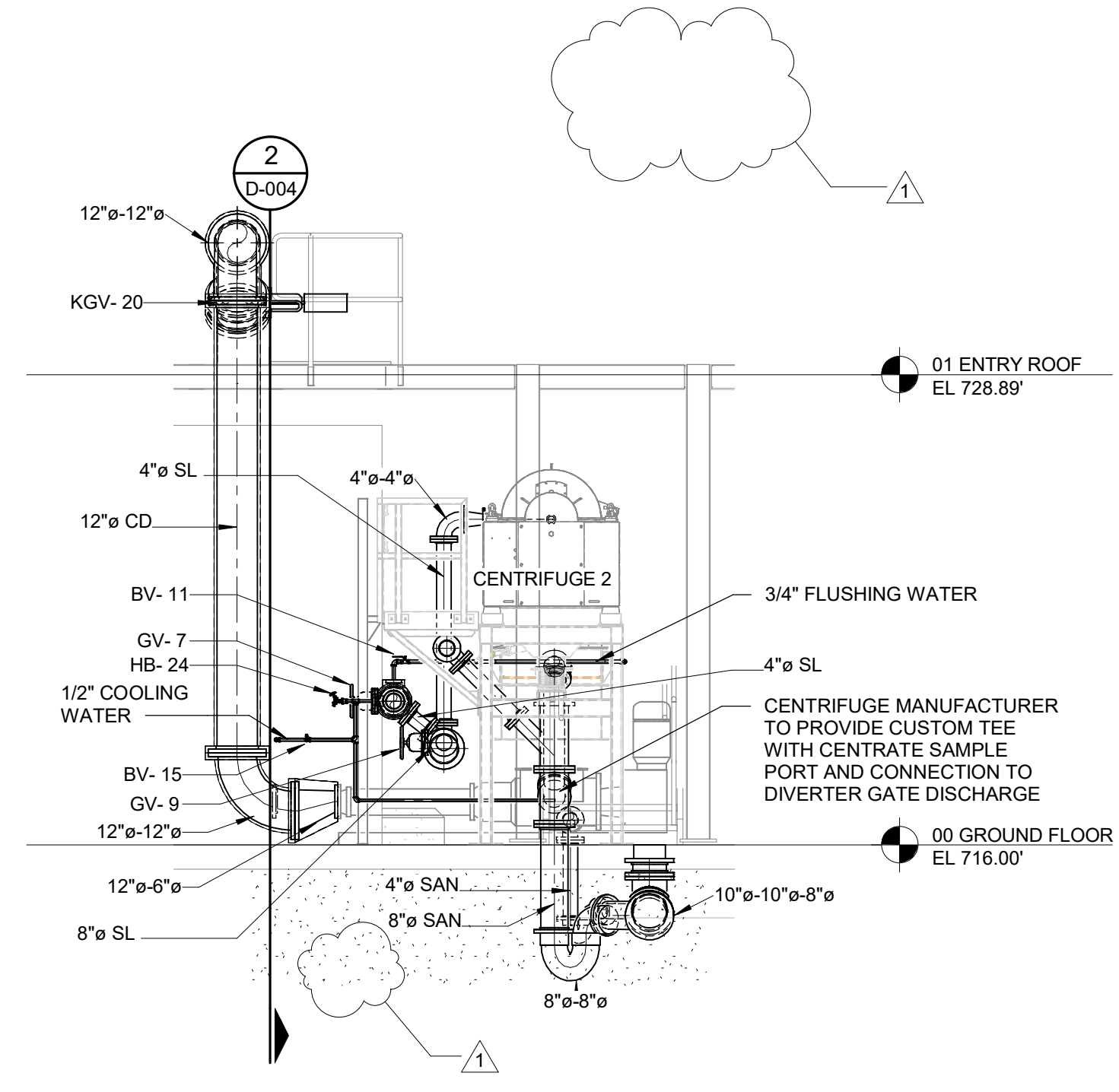

**1**  
D-001 **CENTRIFUGE PIPING DETAIL - RIGHT VIEW**  
SCALE: 1/4" = 1'-0"

NOTES:  
ALL REDUCERS ON SLUDGE LINES, CAKE LINES, AND SERVICE WATER LINES SHALL BE ECCENTRIC (TOPS FLAT).  
ALL ELBOWS ON SLUDGE AND CAKE PIPING SHALL BE LONG RADIUS

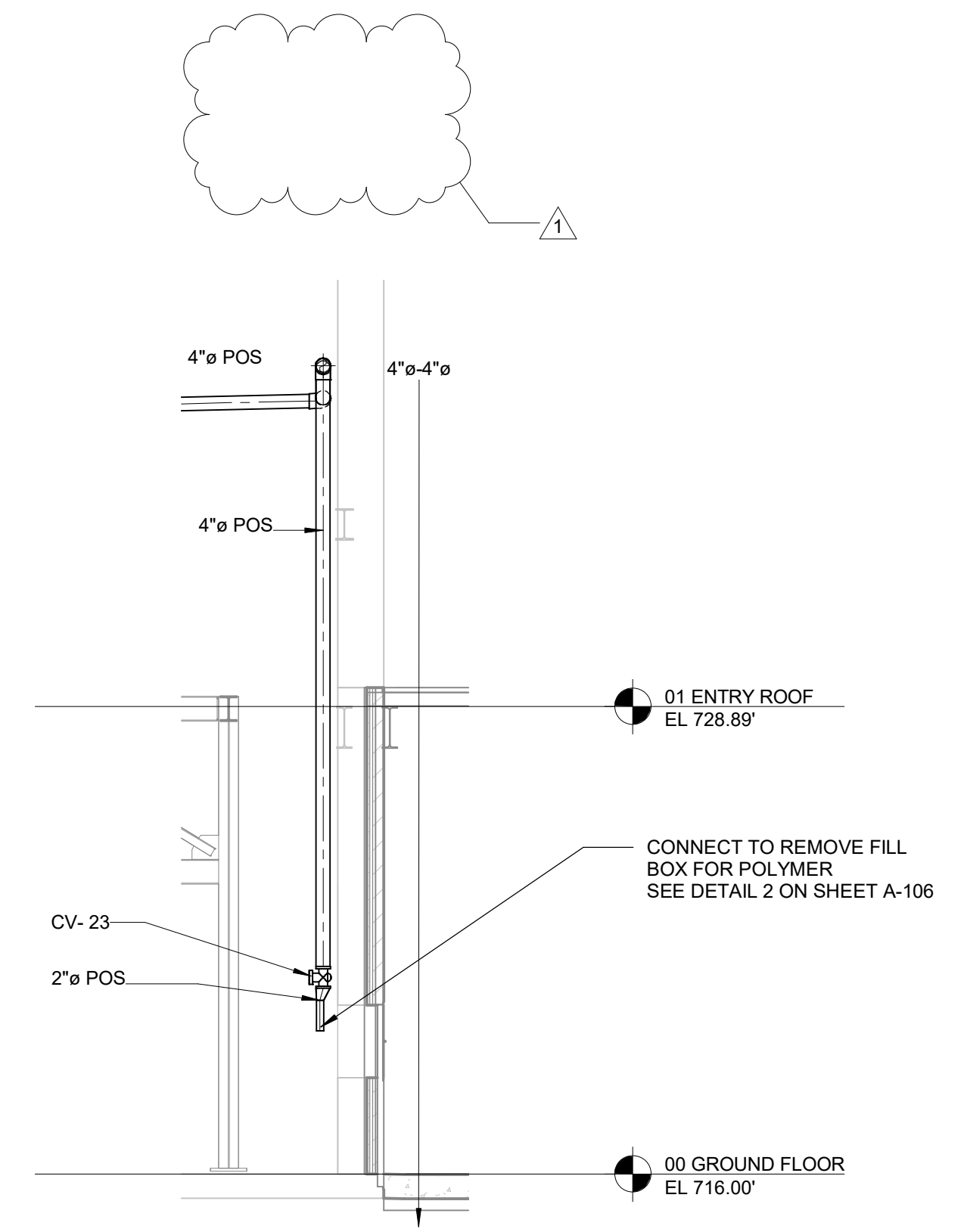

**4**  
D-002 **POLYMER CONNECTION DETAIL**  
SCALE: 1/4" = 1'-0"

REV#	DATE	DESCRIPTION	TH	BY
1	06/15/2020	ADDENDUM 1		



**HRC**  
HUBBELL, ROTH & CLARK, INC.  
CONSULTING ENGINEERS SINCE 1915  
505 WEST BERRY  
BLOOMFIELD HILLS, MICH. 48302-1824  
PHONE: (248) 654-6300  
FAX (Toll Free): (248) 654-6312  
FAX (On Site): (248) 338-2382  
WEB SITE: http://www.hrc-corp.com

CITY OF FLINT  
1101 SAGINAW STREET, FLINT, MICHIGAN 48502  
FLINT WASTE WATER TREATMENT PLANT  
SLUDGE DEWATERING IMPROVEMENTS  
DETAILS

ISSUED FOR:	DATE:	BY:
90% REVIEW	03/25/2020	TH
100% REVIEW	04/17/2020	TH
IFB	06/01/2020	TH

JOB NO.  
COF107201F

SHEET  
D-004

© Wade Trim Group, Inc.



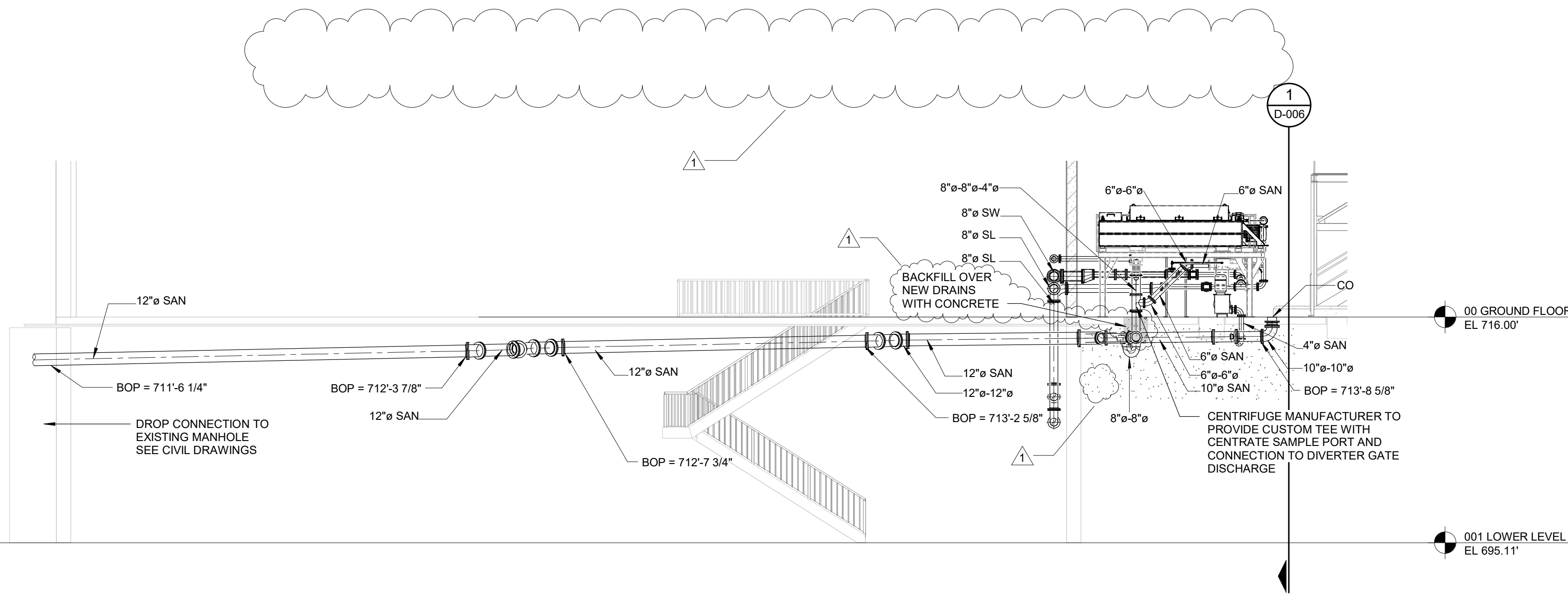

2 DRAIN DETAIL SECTION 2  
D-006 SCALE: 1/8" = 1'-0"

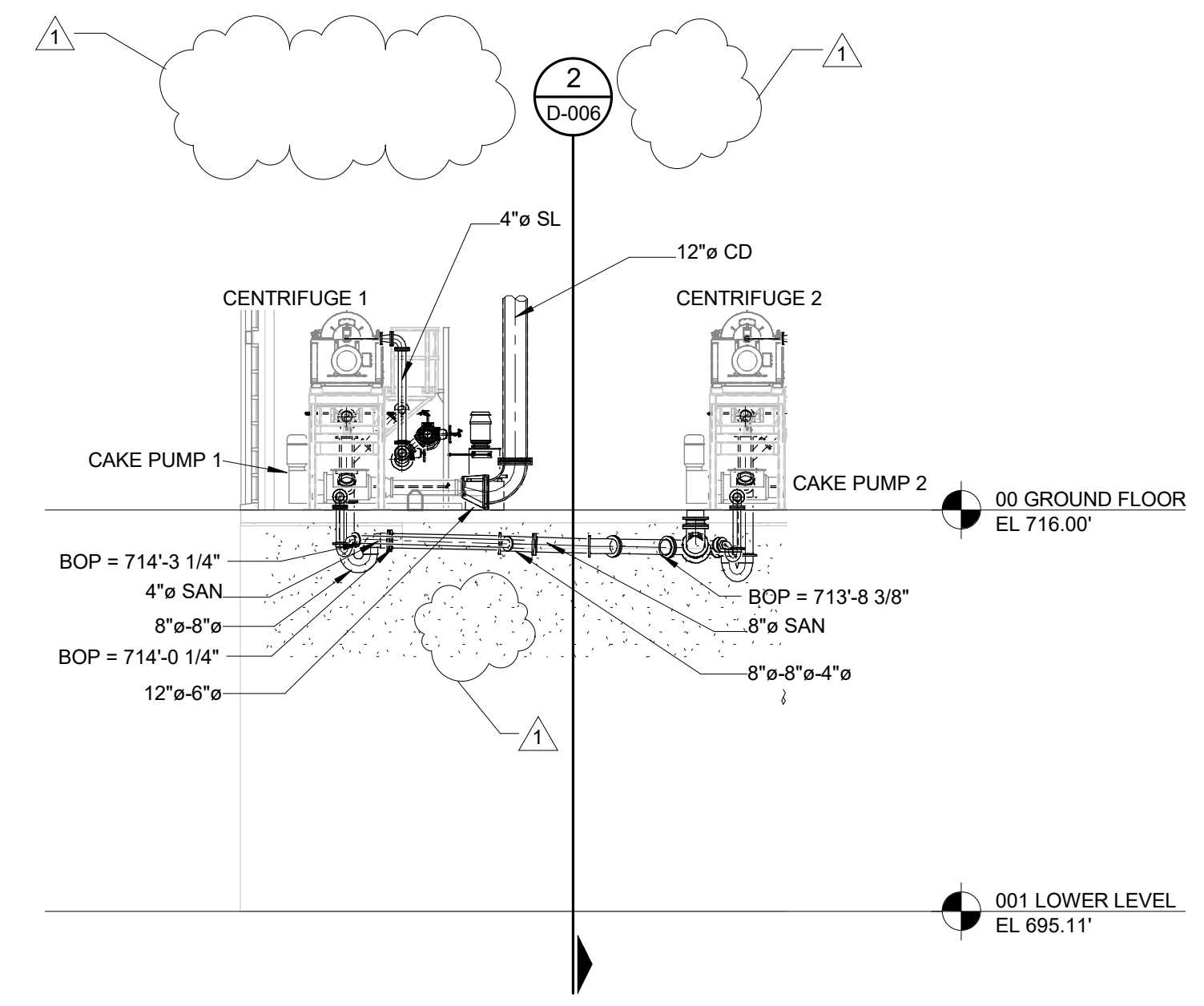

1 DRAIN DETAIL SECTION 1  
D-006 SCALE: 1/8" = 1'-0"

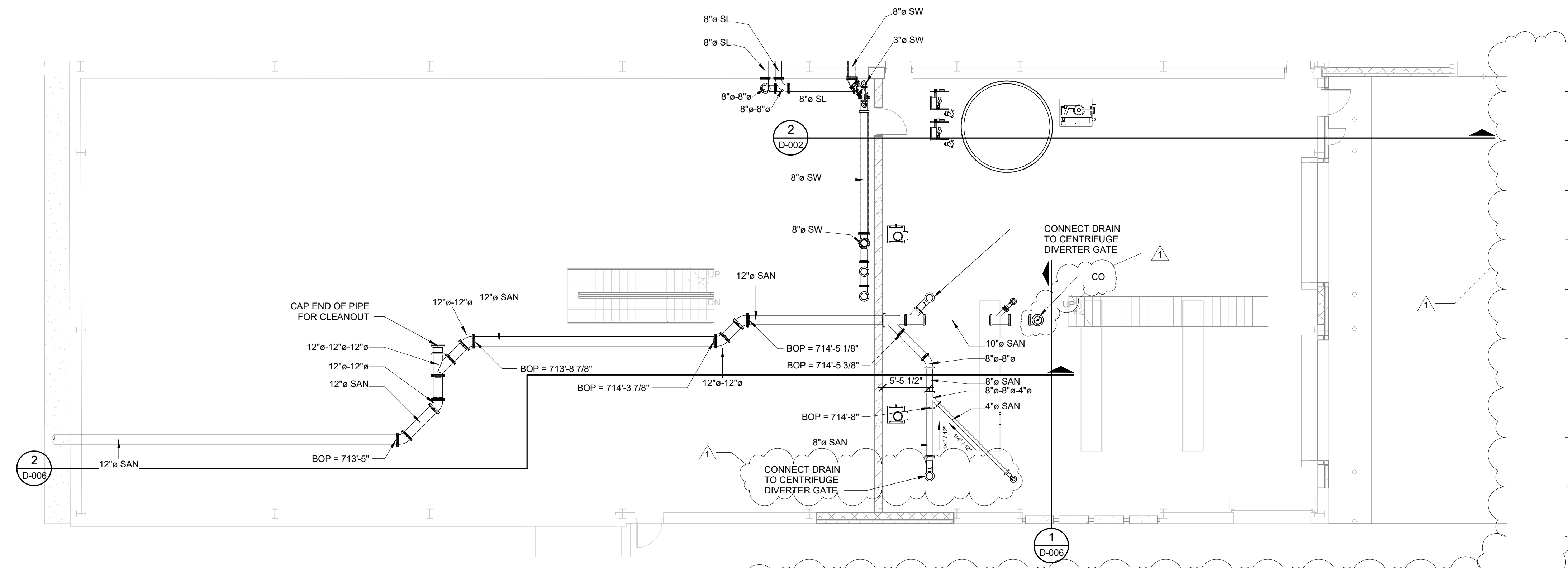

01 GROUND FLOOR DRAIN PLAN  
SCALE: 1/8" = 1'-0"

- NOTES:
- PROVIDE PIPE SLEEVES AND LINK SEAL ALL PIPE PENETRATIONS THROUGH NEW WALLS
  - CORE AND LINK SEAL ALL PIPE PENETRATIONS THROUGH EXISTING WALLS
  - CENTRIFUGE ROOM IS BUILT ON EXISTING SLAB SAWCUT TO INSTALL DRAINS IN FLOOR BACKFILL WITH CONCRETE
  - CLEAN AND TV EXISTING FLOOR DRAINS ON GROUND FLOOR (6 DRAINS)

PLOTTED 2020.06.12 3:31:41 PM

V:\0298348\COF\07201E\_WPC\Sludge-Dewatering-Improvements\_D-17.rvt

REV#	DATE	DESCRIPTION	TH	BY
1	06/15/2020	ADDENDUM 1		



**WADE TRIM**  
555 South Saginaw Street, Suite 201  
Flint, MI 48502  
610.235.2555/800.841.0342  
FAX: 810.235.4975  
www.wadetim.com

**HRC**  
HUBBELL, ROTH & CLARK, INC.  
CONSULTING ENGINEERS SINCE 1915  
500 WEST WYOMING  
BLOOMFIELD HILLS, MICH. 48304-1824  
PHONE: (248) 654-6300  
FAX: (248) 654-6312  
FAX: (248) 338-2382  
WEB SITE: http://www.hrc-corp.com

CITY OF FLINT  
1101 SAGINAW STREET, FLINT, MICHIGAN 48502  
FLINT WASTE WATER TREATMENT PLANT  
SLUDGE DEWATERING IMPROVEMENTS  
DRAIN PIPING

ISSUED FOR:	DATE:	BY:
90% REVIEW	03/25/2020	TH
100% REVIEW	04/17/2020	TH
IFB	06/01/2020	TH

JOB NO. COF107201F
SHEET D-006

© Wade Trim Group, Inc.